

Model Name: **P750QVN01.0**

Issue Date : **2014/08/22**

() Preliminary Specifications

(*) Final Specifications

Customer Signature	Date	AUO	Date
Approved By _____		Approval By PM Director Kelly Kao _____	
Note		Reviewed By RD Director Eugene CC Chen _____	
		Reviewed By Project Leader Jerry.YF.Lin _____	
		Prepared By PM Bryan Chu _____	

Contents

1.	General Description	4
2.	Absolute Maximum Ratings	5
3.	Electrical Specification	6
3.1	Electrical Characteristics	6
3.1.1	DC Characteristics (Ta = 25 ± 2 °C)	6
3.1.2	AC Characteristics (Ta = 25 ± 2 °C)	7
3.1.3	Driver Characteristics	7
3.1.4	TCON Characteristics	7
3.2	Interface Connections	10
3.2.1	V by one color data mapping	15
3.3	Signal Timing Specification	17
3.4	Signal Timing Waveforms	18
3.5	Color Input Data Reference	19
3.6	Power Sequence for LCD	20
3.7	Backlight Specification	21
3.7.1	Electrical specification (Ta = 25 ± 2 °C)	21
3.7.2	Input Pin Assignment	22
3.7.3	Power Sequence for Backlight (CCFL and LED)	23
4.	Optical Specification	24
5.	Mechanical Characteristics	27
5.7	Placement Suggestions	27
6.	Reliability Test Items	31
7.	International Standard	32
7.1	Safety	32
7.2	EMC	32
8.	Packing	33
8.1	Definition of Label	33
8.2	Pallet and Shipment Information	34
9.	Precautions	35
9.1	Mounting Precautions	35
9.2	Operating Precautions	35
9.3	Operating Condition for Public Information Display	36
9.4	Electrostatic Discharge Control	36
9.5	Precautions for Strong Light Exposure	36
9.6	Storage	36
9.7	Handling Precautions for Protection Film	37

1. General Description

This specification applies to the 75 inch Color TFT-LCD Module P750QVN01.0. This LCD module has a TFT active matrix type liquid crystal panel 3840x2160 pixels, and diagonal size of 74.5 inch. This module supports 3840x2160 mode. Each pixel is divided into Red, Green and Blue sub-pixels or dots which are arranged in vertical stripes. Gray scale or the brightness of the sub-pixel color is determined with a 10-bit gray scale signal for each dot.

The P750QVN01.0 has been designed to apply the 10-bit 16 Lanes V by one interface method. It is intended to support displays where high brightness, wide viewing angle.

* General Information

Items	Specification	Unit	Note
Active Screen Size	74.5	inch	
Display Area	1650.24 (H) x 928.26 (V)	mm	
Outline Dimension	1675.8(H) x 953.8(V) x 47.4(D)	mm	D: front bezel to DB cover
Driver Element	a-Si TFT active matrix		
Bezel Opening	1654.2 x 932.4	mm	
Display Colors	10 bit (8 bit + FRC)	Colors	
Number of Pixels	3840x2160	Pixel	
Pixel Pitch	0.4298 (H) x 0.4298 (W)	mm	
Pixel Arrangement	RGB vertical stripe		
Display Operation Mode	Normally Black		
Surface Treatment	Anti-glare, 3H		Haze=2%
Rotate Function	Unachievable		Note 1
Display Orientation	Portrait/Landscape Enabled		Note 2

Note 1: Rotate Function refers to LCD display could be able to rotate. This function does not work in this model.

Note 2: Please refer to 5.1 Placement Suggestions.

2. Absolute Maximum Ratings

The followings are maximum values which, if exceeded, may cause faulty operation or damage to the unit

Item	Symbol	Min	Max	Unit	Conditions
Logic/LCD Drive Voltage	Vcc	-0.3	14	[Volt]	Note 1
Input Voltage of Signal	Vin	-0.3	3.6	[Volt]	Note 1
Operating Temperature	TOP	0	+50	[°C]	Note 2
Operating Humidity	HOP	10	90	[%RH]	Note 2
Storage Temperature	TST	-20	+60	[°C]	Note 2
Storage Humidity	HST	10	90	[%RH]	Note 2
Panel Surface Temperature	PST		65	[°C]	Note 3

Note 1: Duration:50 msec.

Note 2 : Maximum Wet-Bulb should be 39 and No condensation.

The relative humidity must not exceed 90% non-condensing at temperatures of 40 or less. At temperatures greater than 40 , the wet bulb temperature must not exceed 39 .

Note 3: Surface temperature is measured at 50 Dry condition

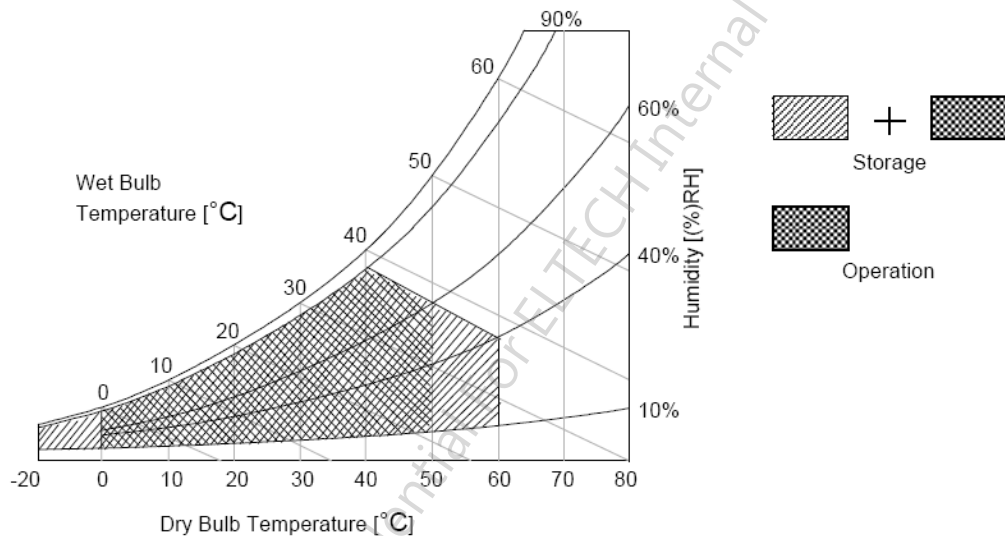

3. Electrical Specification

The P750QVN01.0 requires two power inputs. One is employed to power the LCD electronics and to drive the TFT array and liquid crystal. The other is to power Back Light Unit.

3.1 Electrical Characteristics

3.1.1 DC Characteristics (Ta = 25 ± 2 °C)

Parameter		Symbol	Value			Unit	Note
			Min.	Typ.	Max		
LCD							
Power Supply Input Voltage		V _{DD}	11	12	13.2	V _{DC}	
Power Supply Input Current		I _{DD}	--	3.4	9	A	1
Power Consumption		P _C	--	41	110	Watt	1
Inrush Current		I _{RUSH}	--	--	10	A	2
Permissible Ripple of Power Supply Input Voltage		V _{RP}	--	--	V _{DD} * 5%	mV _{pk-pk}	3
CMOS Interface	Input High Threshold Voltage	V _{IH} (High)	2.7	--	3.3	V _{DC}	4
	Input Low Threshold Voltage	V _{IL} (Low)	0	--	0.6	V _{DC}	4
V-by-one Interface	CML Differential Input High Threshold	V _{RTH}	+50	--	--	mV _{DC}	
	CML Differential Input Low Threshold	V _{RTL}	--	--	-50	mV _{DC}	
	CML Common mode Bias Voltage	V _{RCT}	0.8	0.9	1.0	mV _{DC}	
Backlight Power Consumption		P _{BL}		300	350	Watt	
Life time (MTTF)			35000			Hour	9,10

3.1.2 AC Characteristics (Ta = 25 ± 2 °C)

Parameter	Symbol	Value			Unit	Note
		Min.	Typ.	Max		
VRXINP/N input each bit Period	T _{RRIP} (UI)	310	--	379	ps	5
CDR lock time(CDR training)	T _{RLCK0}	--	--	1.0	ms	5
Receiver Clock : Spread Spectrum Modulation range	Fclk _{ss}	Fclk -0.5%	--	Fclk +0.5%	MHz	
Receiver Clock : Spread Spectrum Modulation frequency	F _{ss}	30			KHz	
ALN Training	T _{RALN}	--	40960	--	UI	5
PDX active to hot plug enable	T _{RHPD0}	--	--	1.0	us	5
Intra-pair skew	T _{INTRA}	--	--	0.3	UI	6
Inter-pair skew	T _{INTER}	--	--	5	UI	7
Eye diagram at receiver	A_X	--	0.25	--	UI	8
	A_Y	--	0	--	mV	
	B_X	--	0.3	--	UI	
	B_Y	--	50	--	mV	
	C_X	--	0.7	--	UI	
	C_Y	--	50	--	mV	
	D_X	--	0.75	--	UI	
	D_Y	--	0	--	mV	
	E_X	--	0.7	--	UI	
	E_Y	--	-50	--	mV	
	F_X	--	0.3	--	UI	
	F_Y	--	-50	--	mV	

3.1.3 Driver Characteristics

Item	Symbol	Min	Max	Unit	condition
Driver Surface Temperature	DST		100	[]	Note

Note : Any point on the driver surface must be less than 100 under any conditions.

3.1.4 TCON Characteristics

Item	Symbol	Min	Max	Unit	condition
TCON Surface Temperature	TST		85	[]	Note

Note: Any point on the TCON surface must be less than 85 under any conditions.

Note:

1. Test Condition:
 - (1) $V_{DD} = 12.0V$
 - (2) $F_v = 120Hz$
 - (3) $F_{clk} = \text{Max freq.}$
 - (4) Temperature = 25
 - (5) Typ. Input current : White Pattern
Max. Input current: Heavy loading pattern defined by AUO

>> refer to "Section:3.3 Signal Timing Specification, Typical timing"
2. Measurement condition : Rising time = 400us

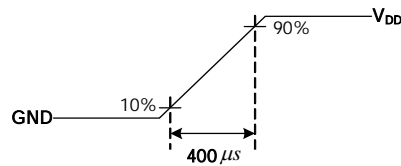

3. Test Condition:
 - (1) The measure point of V_{RP} is in LCM side after connecting the System Board and LCM.
 - (2) Under Max. Input current spec. condition.
4. The measure points of V_{IH} and V_{IL} are in LCM side after connecting the System Board and LCM.
5. V-by-one Receiver start up timing waveform

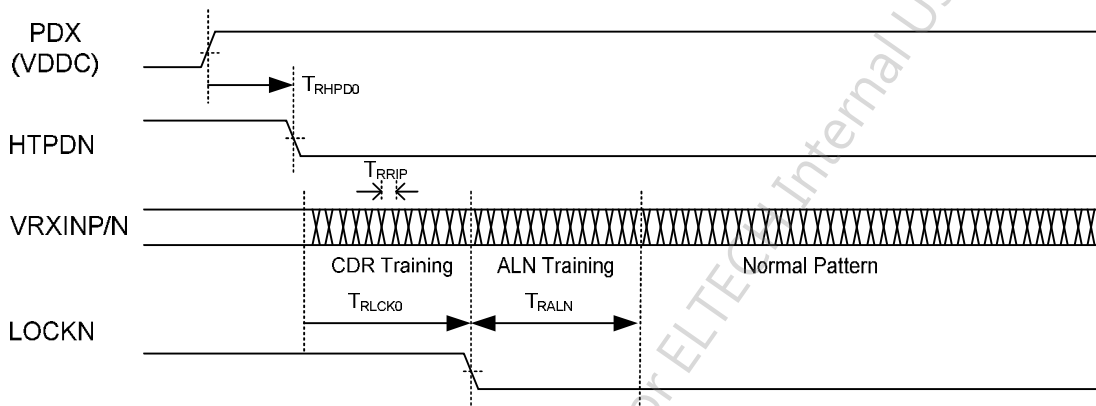

6. V-by-one Intra-pair Skew

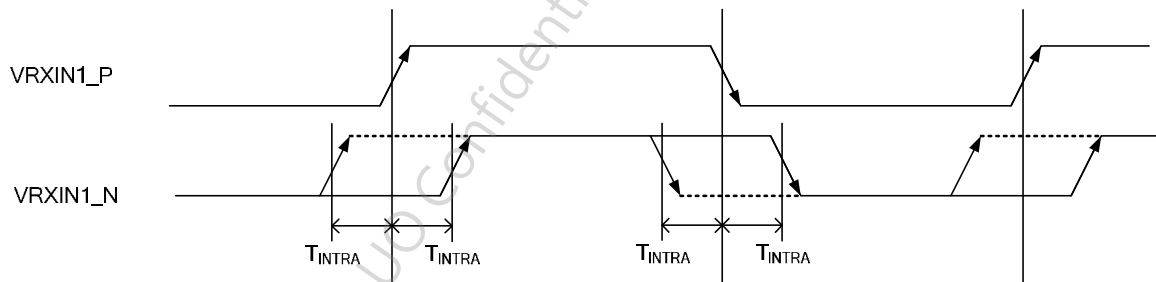

7. V-by-one Inter-pair Skew

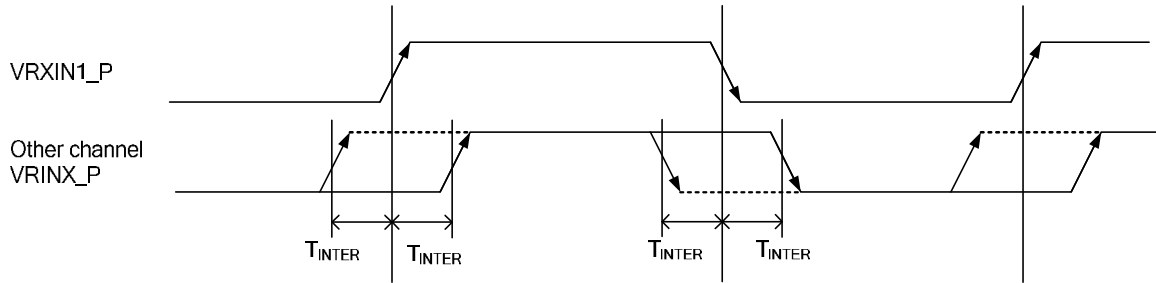

8. Eye diagram at receiver

Eye Mask

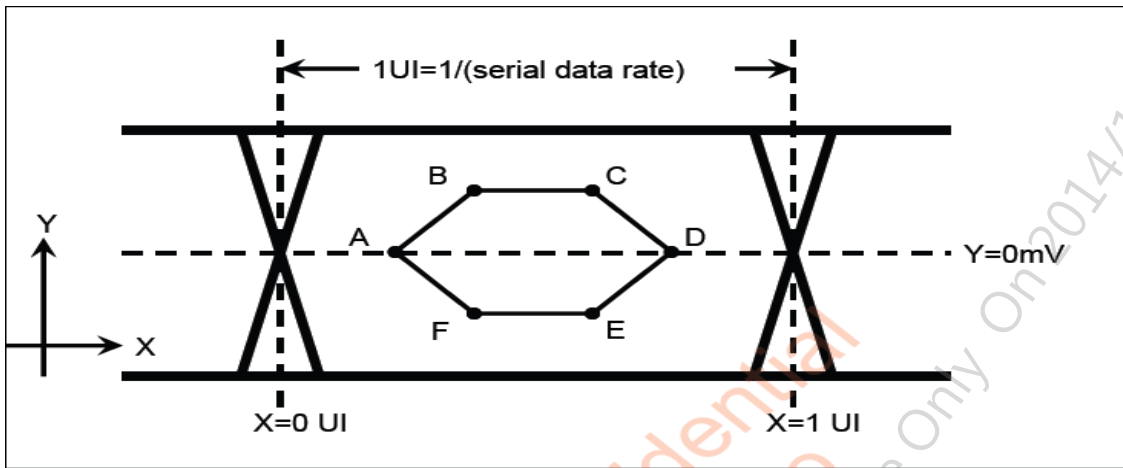

Example of Eye diagram



9. The relative humidity must not exceed 80% non-condensing at temperatures of 40 or less. At temperatures greater than 40, the wet bulb temperature must not exceed 39.
10. The lifetime (MTTF) is defined as the time which luminance of LED is 50% compared to its original value. [Operating condition: Continuous operating at $T_a = 25 \pm 2$, for single lamp/LED only]

Interface Connections

- 51pin LCD connector: FI-RE51S-HF (JAE, V-by-One 51pin connector)

PIN	Symbol	Description
1	N.C.	No connection (for AUO test only. Do not connect)
2	N.C.	No connection (for AUO test only. Do not connect)
3	N.C.	No connection (for AUO test only. Do not connect)
4	N.C.	No connection (for AUO test only. Do not connect)
5	N.C.	No connection (for AUO test only. Do not connect)
6	N.C.	No connection (for AUO test only. Do not connect)
7	N.C.	No connection (for AUO test only. Do not connect)
8	N.C.	No connection (for AUO test only. Do not connect)
9	N.C.	No connection (for AUO test only. Do not connect)
10	GND	Ground
11	GND	Ground
12	GND	Ground
13	GND	Ground
14	GND	Ground
15	N.C.	No connection (for AUO test only. Do not connect)
16	N.C.	No connection (for AUO test only. Do not connect)
17	N.C.	No connection (for AUO test only. Do not connect)
18	N.C.	No connection (for AUO test only. Do not connect)
19	N.C.	No connection (for AUO test only. Do not connect)
20	N.C.	No connection (for AUO test only. Do not connect)
21	N.C.	No connection (for AUO test only. Do not connect)
22	N.C.	No connection (for AUO test only. Do not connect)
23	N.C.	No connection (for AUO test only. Do not connect)
24	GND	Ground
25	HTPDN	Vx1 HTPDN
26	LOCKN	Vx1 LOCKN
27	GND	Ground
28	RX0N	Vx1 lane 0
29	RX0P	Vx1 lane 0
30	GND	Ground
31	RX1N	Vx1 lane 1
32	Rx1P	Vx1 lane 1

33	GND	Ground
34	RX2N	Vx1 lane 2
35	RX2P	Vx1 lane2
36	GND	Ground
37	RX3N	Vx1 lane 3
38	RX3P	Vx1 lane 3
39	GND	Ground
40	RX4N	Vx1 lane 4
41	RX4P	Vx1 lane 4
42	GND	Ground
43	RX5N	Vx1 lane 5
44	RX5P	Vx1 lane 5
45	GND	Ground
46	RX6N	Vx1 lane 6
47	RX6P	Vx1 lane 6
48	GND	Ground
49	RX7N	Vx1 lane 7
50	RX7P	Vx1 lane 7
51	GND	Ground

- 41pin LCD connector: FI-RE41S-HF (JAE, V-by-One 41pin connector)

PIN	Symbol	Description
1	GND	GND
2	RX8N	RX8N
3	RX8P	RX8P
4	GND	GND
5	RX9N	RX9N
6	RX9P	RX9P
7	GND	GND
8	RX10N	RX10N
9	RX10P	RX10P
10	GND	GND
11	RX11N	RX11N
12	RX11P	RX11P
13	GND	GND
14	RX12N	RX12N
15	RX12P	RX12P

16	GND	GND
17	RX13N	RX13N
18	RX13P	RX13P
19	GND	GND
20	RX14N	RX14N
21	RX14P	RX14P
22	GND	GND
23	RX15N	RX15N
24	RX15P	RX15P
25	GND	GND
26	N.C.	No connection (for AUO test only. Do not connect)
27	N.C.	No connection (for AUO test only. Do not connect)
28	N.C.	No connection (for AUO test only. Do not connect)
29	N.C.	No connection (for AUO test only. Do not connect)
30	N.C.	No connection (for AUO test only. Do not connect)
31	N.C.	No connection (for AUO test only. Do not connect)
32	N.C.	No connection (for AUO test only. Do not connect)
33	N.C.	No connection (for AUO test only. Do not connect)
34	GND	GND
35	N.C.	No connection (for AUO test only. Do not connect)
36	N.C.	No connection (for AUO test only. Do not connect)
37	N.C.	No connection (for AUO test only. Do not connect)
38	N.C.	No connection (for AUO test only. Do not connect)
39	N.C.	No connection (for AUO test only. Do not connect)
40	N.C.	No connection (for AUO test only. Do not connect)
41	N.C.	No connection (for AUO test only. Do not connect)

- 12pin LCD connector for 12V power: SM12B-PASS-TB

PIN	Symbol	Description
1	V _{DD}	Power Supply, +12V DC Regulated
2	V _{DD}	Power Supply, +12V DC Regulated
3	V _{DD}	Power Supply, +12V DC Regulated
4	V _{DD}	Power Supply, +12V DC Regulated
5	V _{DD}	Power Supply, +12V DC Regulated
6	NC	No connection (for AUO test only. Do not connect)
7	NC	No connection (for AUO test only. Do not connect)
8	GND	Ground
9	GND	Ground

10	GND	Ground
11	GND	Ground
12	GND	Ground

Note: N.C. : please leave this pin unoccupied. It can not be connected by any signal

4K2K Input Data Format :

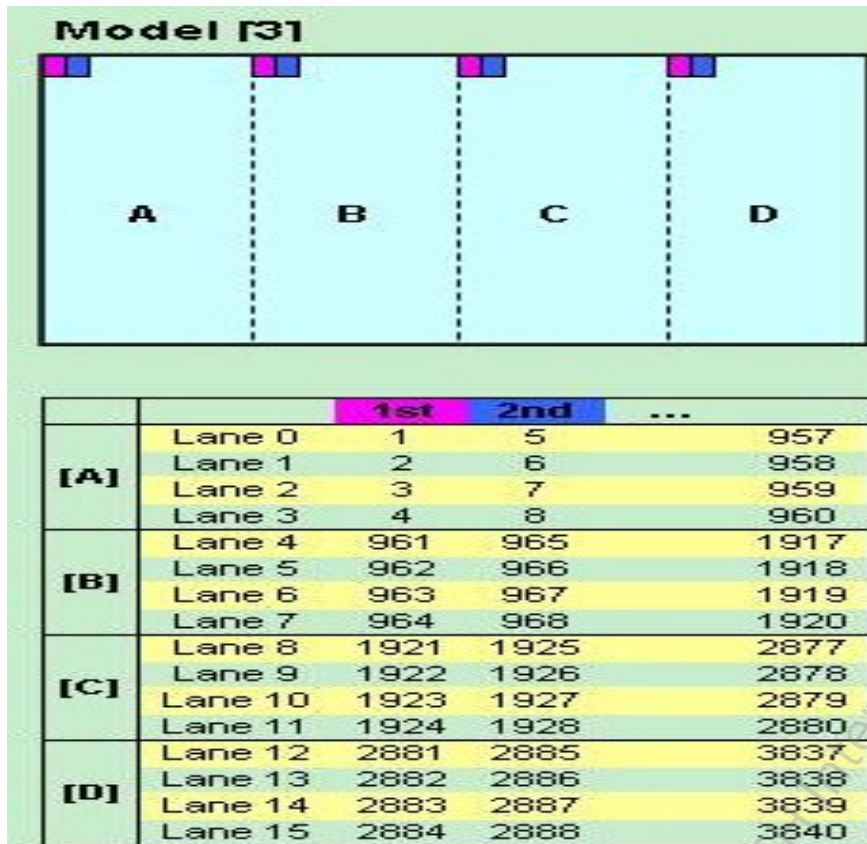

AUO Confidential For ELTECH Internal Use Only On 2014/10/08

V-by-One Lanes of Pixel Data :

	Lane 0	Lane 1	Lane 2	Lane 3	Lane 4	Lane 5	Lane 6	Lane 7
Blank	FSBS	FSBS	FSBS	FSBS	FSBS	FSBS	FSBS	FSBS
	FSBP	FSBP	FSBP	FSBP	FSBP	FSBP	FSBP	FSBP
	FSBE_SR	FSBE_SR	FSBE_SR	FSBE_SR	FSBE_SR	FSBE_SR	FSBE_SR	FSBE_SR
Line 1	Pixel 1	Pixel 2	Pixel 3	Pixel 4	Pixel 5	Pixel 6	Pixel 7	Pixel 8
	Pixel 9	Pixel 10	Pixel 11	Pixel 12	Pixel 13	Pixel 14	Pixel 15	Pixel 16

Blank	Pixel 1913	Pixel 1914	Pixel 1915	Pixel 1916	Pixel 1917	Pixel 1918	Pixel 1919	Pixel 1920
	FSBS	FSBS	FSBS	FSBS	FSBS	FSBS	FSBS	FSBS
	FSBP	FSBP	FSBP	FSBP	FSBP	FSBP	FSBP	FSBP
Line 2	FSBE_SR	FSBE_SR	FSBE_SR	FSBE_SR	FSBE_SR	FSBE_SR	FSBE_SR	FSBE_SR
	Pixel 1	Pixel 2	Pixel 3	Pixel 4	Pixel 5	Pixel 6	Pixel 7	Pixel 8
	Pixel 9	Pixel 10	Pixel 11	Pixel 12	Pixel 13	Pixel 14	Pixel 15	Pixel 16
.	
Blank	Pixel 1913	Pixel 1914	Pixel 1915	Pixel 1916	Pixel 1917	Pixel 1918	Pixel 1919	Pixel 1920

	Lane 8	Lane 9	Lane 10	Lane 11	Lane 12	Lane 13	Lane 14	Lane 15
Blank	FSBS	FSBS	FSBS	FSBS	FSBS	FSBS	FSBS	FSBS
	FSBP	FSBP	FSBP	FSBP	FSBP	FSBP	FSBP	FSBP
	FSBE_SR	FSBE_SR	FSBE_SR	FSBE_SR	FSBE_SR	FSBE_SR	FSBE_SR	FSBE_SR
Line 1	Pixel 1921	Pixel 1922	Pixel 1923	Pixel 1924	Pixel 1925	Pixel 1926	Pixel 1927	Pixel 1928
	Pixel 1929	Pixel 1930	Pixel 1931	Pixel 1932	Pixel 1933	Pixel 1934	Pixel 1935	Pixel 1936

Blank	Pixel 3833	Pixel 3834	Pixel 3835	Pixel 3836	Pixel 3837	Pixel 3838	Pixel 3839	Pixel 3840
	FSBS	FSBS	FSBS	FSBS	FSBS	FSBS	FSBS	FSBS
	FSBP	FSBP	FSBP	FSBP	FSBP	FSBP	FSBP	FSBP
Line 2	FSBE_SR	FSBE_SR	FSBE_SR	FSBE_SR	FSBE_SR	FSBE_SR	FSBE_SR	FSBE_SR
	Pixel 1921	Pixel 1922	Pixel 1923	Pixel 1924	Pixel 1925	Pixel 1926	Pixel 1927	Pixel 1928
	Pixel 1929	Pixel 1930	Pixel 1931	Pixel 1932	Pixel 1933	Pixel 1934	Pixel 1935	Pixel 1936
.	
Blank	Pixel 3833	Pixel 3834	Pixel 3835	Pixel 3836	Pixel 3837	Pixel 3838	Pixel 3839	Pixel 3840

AUO Confidential For ELTECH Internal Use Only On 2014/10/08

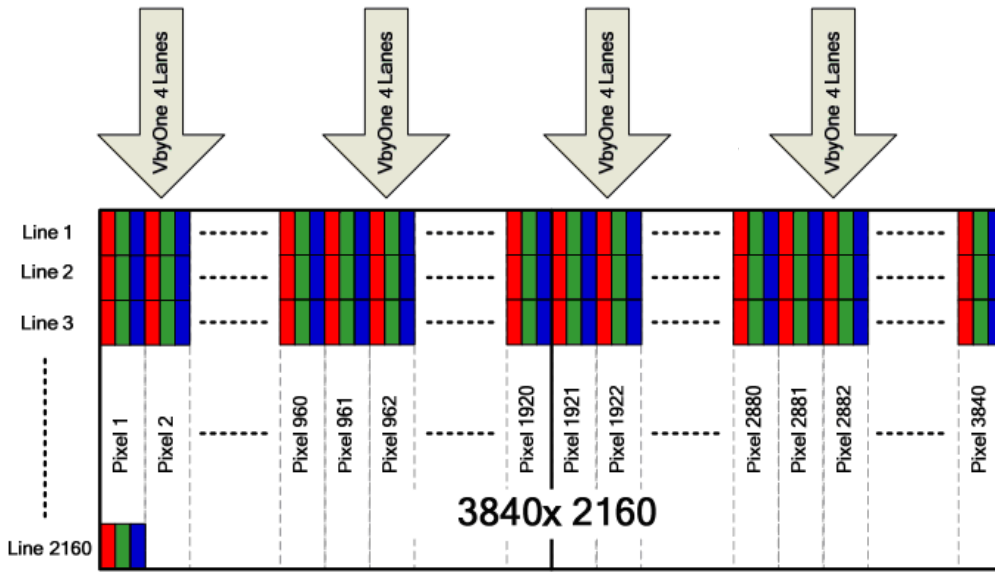

Note: Normal pixel data mapping

Pixel No	Pixel 1			Pixel 2			Pixel 3			~	Pixel 3840			
Line 1	R1	G1	B1	R2	G2	B2	R3	G3	B3	R4	~	R3840	G3840	B3840
Line 2	R1	G1	B1	R2	G2	B2	R3	G3	B3	R4	~	R3840	G3840	B3840
Line 3	R1	G1	B1	R2	G2	B2	R3	G3	B3	R4	~	R3840	G3840	B3840
Line 4	R1	G1	B1	R2	G2	B2	R3	G3	B3	R4	~	R3840	G3840	B3840
Line 5	R1	G1	B1	R2	G2	B2	R3	G3	B3	R4	~	R3840	G3840	B3840
Line 6	R1	G1	B1	R2	G2	B2	R3	G3	B3	R4	~	R3840	G3840	B3840
:	:	:	:	:	:	:	:	:	:	:	:	:	:	:
Line 2158	R1	G1	B1	R2	G2	B2	R3	G3	B3	R4	~	R3840	G3840	B3840
Line 2159	R1	G1	B1	R2	G2	B2	R3	G3	B3	R4	~	R3840	G3840	B3840
Line 2160	R1	G1	B1	R2	G2	B2	R3	G3	B3	R4	~	R3840	G3840	B3840

3.1.5 V by one color data mapping

Mode	Packer input & Unpacker output		30bpp RGB /YCbCr444(10bit)	24bpp RGB /YCbCr444(8bit)
4byte mode 3byte mode	Byte0	D[0]	R/Cr[2]	R/Cr[0]
		D[1]	R/Cr[3]	R/Cr[1]
		D[2]	R/Cr[4]	R/Cr[2]
		D[3]	R/Cr[5]	R/Cr[3]
		D[4]	R/Cr[6]	R/Cr[4]
		D[5]	R/Cr[7]	R/Cr[5]
		D[6]	R/Cr[8]	R/Cr[6]
		D[7]	R/Cr[9]	R/Cr[7]

	Byte1	D[8]	G/Y[2]	G/Y[0]	
		D[9]	G/Y[3]	G/Y[1]	
		D[10]	G/Y[4]	G/Y[2]	
		D[11]	G/Y[5]	G/Y[3]	
		D[12]	G/Y[6]	G/Y[4]	
		D[13]	G/Y[7]	G/Y[5]	
		D[14]	G/Y[8]	G/Y[6]	
		D[15]	G/Y[9]	G/Y[7]	
		Byte2	D[16]	B/Cb[2]	B/Cb[0]
			D[17]	B/Cb[3]	B/Cb[1]
			D[18]	B/Cb[4]	B/Cb[2]
			D[19]	B/Cb[5]	B/Cb[3]
			D[20]	B/Cb[6]	B/Cb[4]
			D[21]	B/Cb[7]	B/Cb[5]
			D[22]	B/Cb[8]	B/Cb[6]
	D[23]		B/Cb[9]	B/Cb[7]	
	Byte3	D[24]	--		
		D[25]	--		
		D[26]	B/Cb[0]		
		D[27]	B/Cb[1]		
		D[28]	G/Y[0]		
		D[29]	G/Y[1]		
		D[30]	R/Cr[0]		
		D[31]	R/Cr[1]		

AUO Confidential For ELTECH Internal Use Only On 2014/10/08

3.2 Signal Timing Specification

This is the signal timing required at the input of the user connector. All of the interface signal timing should be satisfied with the following specifications for its proper operation.

Timing Table

Signal	Item	Symbol	Min.	Typ.	Max	Unit
Vertical Section	Period	Tv	2200	2250	2715	Th
	Active	Tdisp (v)	2160			
	Blanking	Tblk (v)	40	90	555	Th
Horizontal Section	Period	Th	270	275	300	Tclk
	Active	Tdisp (h)	240			
	Blanking	Tblk (h)	30	35	60	Tclk
Clock	Frequency	Fclk=1/Tclk	66	74.25	77	MHz
Vertical Frequency	Frequency	Fv	94	120	122	Hz
Horizontal Frequency	Frequency	Fh	240	270	278.4	KHz

V-sync Request

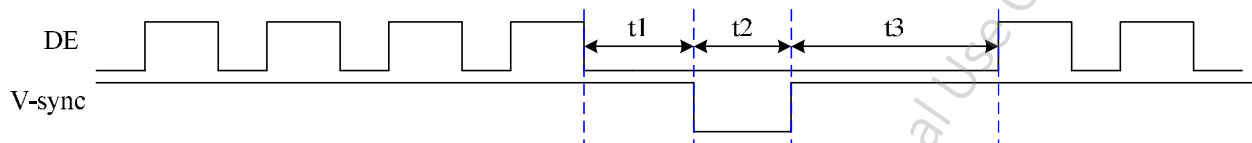

- t1 2H
- t2 1H
- t3 13H
- t1+t2+t3 20T

Where H means H-total period

H-sync Request

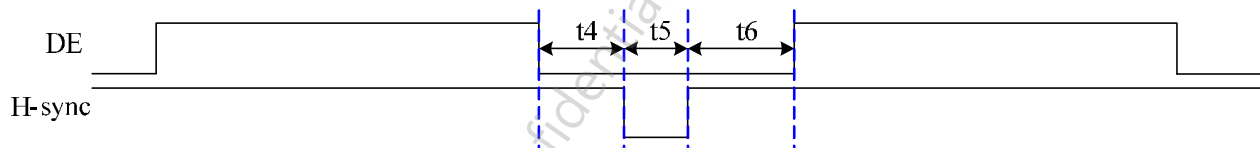

- t4 10T
- t5 5T
- t6 10T
- t4+t5+t6 30T

Where T means pixel clock period

3.3 Signal Timing Waveforms

Four Section Mode (Lane1~16 V-by one data:1, 2, 3, 4, 961, 962, 963, 964, 1921, 1922, 1923, 1924, 2881, 2882, 2883, 2884)

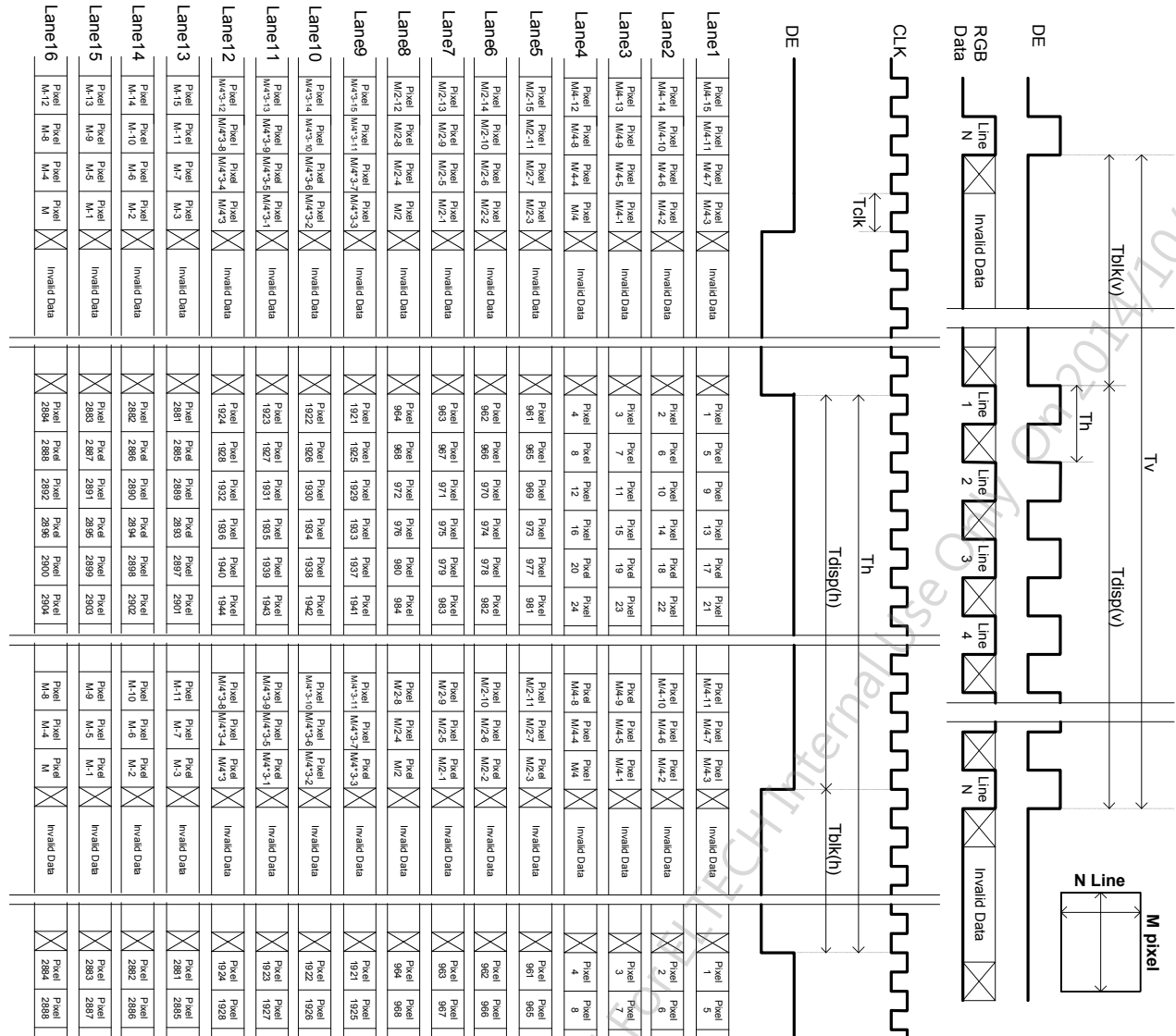

3.5 Color Input Data Reference

The brightness of each primary color (red, green and blue) is based on the 8 bit + FRC gray scale data input for the color; the higher the binary input, the brighter the color. The table below provides a reference for color versus data input.

COLOR DATA REFERENCE

Color		Input Color Data																													
		RED										GREEN										BLUE									
		MSB					LSB					MSB					LSB					MSB					LSB				
		R9	R8	R7	R6	R5	R4	R3	R2	R1	R0	G9	G8	G7	G6	G5	G4	G3	G2	G1	G0	B9	B8	B7	B6	B5	B4	B3	B2	B1	B0
Basic Color	Black	0	0	0	0	0	0	0	0	0	0	0	0	0	0	0	0	0	0	0	0	0	0	0	0	0	0	0	0	0	0
	Red(1023)	1	1	1	1	1	1	1	1	1	1	0	0	0	0	0	0	0	0	0	0	0	0	0	0	0	0	0	0	0	0
	Green(1023)	0	0	0	0	0	0	0	0	0	0	1	1	1	1	1	1	1	1	1	1	0	0	0	0	0	0	0	0	0	0
	Blue(1023)	0	0	0	0	0	0	0	0	0	0	0	0	0	0	0	0	0	0	0	0	1	1	1	1	1	1	1	1	1	1
	Cyan	0	0	0	0	0	0	0	0	0	0	1	1	1	1	1	1	1	1	1	1	1	1	1	1	1	1	1	1	1	1
	Magenta	1	1	1	1	1	1	1	1	1	1	0	0	0	0	0	0	0	0	0	0	1	1	1	1	1	1	1	1	1	1
	Yellow	1	1	1	1	1	1	1	1	1	1	1	1	1	1	1	1	1	1	1	1	0	0	0	0	0	0	0	0	0	0
	White	1	1	1	1	1	1	1	1	1	1	1	1	1	1	1	1	1	1	1	1	1	1	1	1	1	1	1	1	1	1
R	RED(000)	0	0	0	0	0	0	0	0	0	0	0	0	0	0	0	0	0	0	0	0	0	0	0	0	0	0	0	0	0	
	RED(001)	0	0	0	0	0	0	0	0	0	0	0	0	0	0	0	0	0	0	0	0	0	0	0	0	0	0	0	0	0	

	RED(1022)	1	1	1	1	1	1	1	1	1	0	0	0	0	0	0	0	0	0	0	0	0	0	0	0	0	0	0	0	0	
	RED(1023)	1	1	1	1	1	1	1	1	1	0	0	0	0	0	0	0	0	0	0	0	0	0	0	0	0	0	0	0	0	
G	GREEN(000)	0	0	0	0	0	0	0	0	0	0	0	0	0	0	0	0	0	0	0	0	0	0	0	0	0	0	0	0	0	
	GREEN(001)	0	0	0	0	0	0	0	0	0	0	0	0	0	0	0	0	0	0	1	0	0	0	0	0	0	0	0	0	0	

	GREEN(1022)	0	0	0	0	0	0	0	0	0	1	1	1	1	1	1	1	1	1	0	0	0	0	0	0	0	0	0	0	0	
	GREEN(1023)	0	0	0	0	0	0	0	0	0	1	1	1	1	1	1	1	1	1	1	0	0	0	0	0	0	0	0	0	0	
B	BLUE(000)	0	0	0	0	0	0	0	0	0	0	0	0	0	0	0	0	0	0	0	0	0	0	0	0	0	0	0	0	0	
	BLUE(001)	0	0	0	0	0	0	0	0	0	0	0	0	0	0	0	0	0	0	0	0	0	0	0	0	0	0	0	0	1	

	BLUE(1022)	0	0	0	0	0	0	0	0	0	0	0	0	0	0	0	0	0	0	0	1	1	1	1	1	1	1	1	1	0	
	BLUE(1023)	0	0	0	0	0	0	0	0	0	0	0	0	0	0	0	0	0	0	0	1	1	1	1	1	1	1	1	1	1	

3.6 Power Sequence for LCD

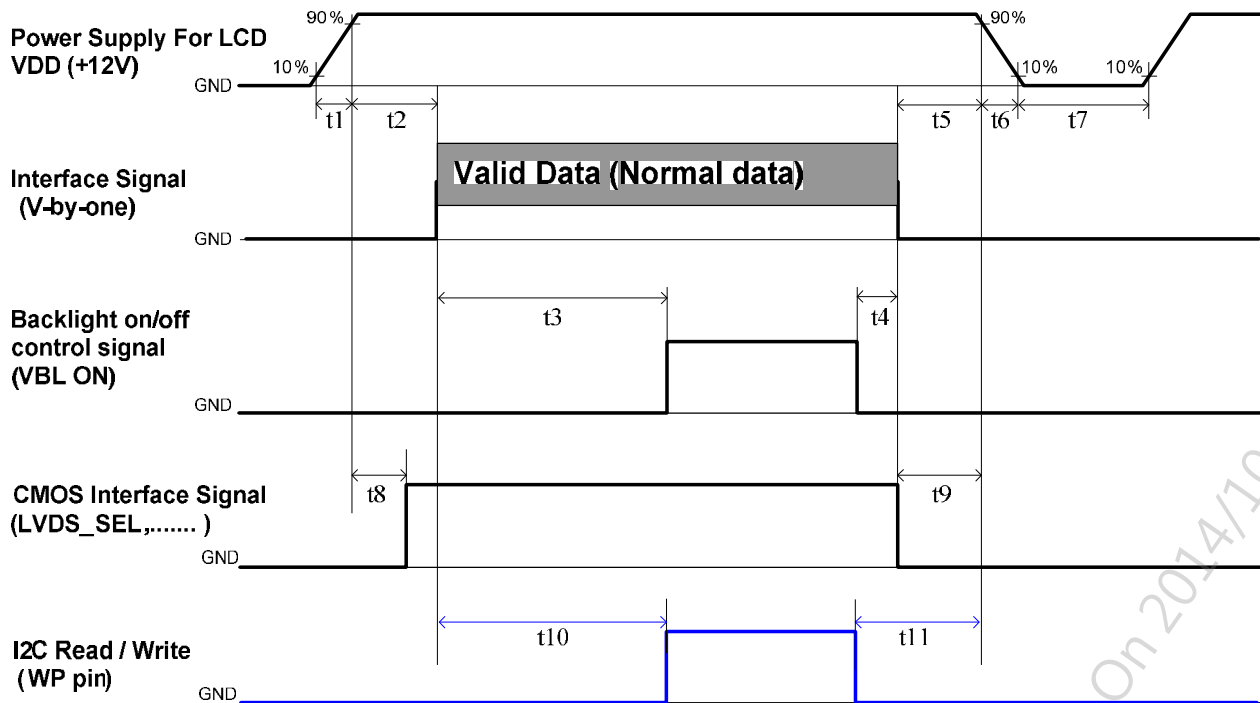

Parameter	Values			Unit
	Min.	Type.	Max.	
t1	0.4	---	30	ms
t2	40	---	---	ms
t3	860	---	---	ms
t4	0 ^{*1}	---	---	ms
t5	0	---	---	ms
t6	---	---	--- ^{*2}	ms
t7	500	---	---	ms
t8	20 ^{*4}	---	50	ms
t9	0	---	---	ms
t10	860	---	---	ms
t11	150 ^{*3}	---	---	ms

Note:

- (1) t4=0 : concern for residual pattern before BLU turn off.
- (2) t6 : voltage of VDD must decay smoothly after power-off. (customer system decide this value)
- (3) When CMOS Interface signal is N.C. (no connection), opened in Transmitted end, t8 timing spec can be negligible.

3.7 Backlight Specification

3.7.1 Electrical specification (Ta = 25 ± 2 °C)

	Item	Symbol	Condition	Spec			Unit	Note	
				Min	Typ	Max			
1	Input Voltage	V _{DDB}	-	22.8	24	25.2	VDC	-	
2	Input Current	I _{DDB}	V _{DDB} =24V		11	12.58	ADC	1	
3	Input Power	P _{DDB}	V _{DDB} =24V		300	350	W	1	
4	Inrush Current	I _{RUSH}	V _{DDB} =24V			20	ADC	2	
5	On/Off control voltage	V _{B_{LON}}	ON	V _{DDB} =24V	2	-	3.3	VDC	-
			OFF		-0.3	-	0.8		-
6	On/Off control current	I _{B_{LON}}	V _{DDB} =24V	-	-	1.5	mA	-	
7	External PWM Control Voltage	V _{EPWM}	MAX	V _{DDB} =24V	2	-	5.5	VDC	-
			MIN		0	-	0.8		-
8	External PWM Control Current	I _{EPWM}	V _{DDB} =24V	-	-	2	mADC	-	
9	External PWM Duty ratio	D _{EPWM}	V _{DDB} =24V	5	-	100	%	3	
10	External PWM Frequency	F _{EPWM}	V _{DDB} =24V	90		240	Hz	-	
11	DET status signal	DET	Hi	V _{DDB} =24V	Open Collector		VDC	4	
			Lo		0	-	0.8	VDC	4
12	Input Impedance	R _{in}	V _{DDB} =24V	300			Kohm	-	

Note 1 : Dimming ratio= 100% (MAX) (Ta=25±5 , Turn on for 45minutes)

Note 2: Measurement condition Rising time = 20ms (V_{DDB} : 10%~90%);

Note 3: Less than 5% dimming control is functional well and no backlight shutdown happened

Note 4: Normal : 0~0.8V ; Abnormal : Open collector

3.7.2 Input Pin Assignment

LED driver board connector : Cvilux CI0114M1HR0-NH

Pin	Symbol	Description
1	VDDB	Operating Voltage Supply, +24V DC regulated
2	VDDB	Operating Voltage Supply, +24V DC regulated
3	VDDB	Operating Voltage Supply, +24V DC regulated
4	VDDB	Operating Voltage Supply, +24V DC regulated
5	VDDB	Operating Voltage Supply, +24V DC regulated
6	BLGND	Ground and Current Return
7	BLGND	Ground and Current Return
8	BLGND	Ground and Current Return
9	BLGND	Ground and Current Return
10	BLGND	Ground and Current Return
11	DET	BLU status detection: Normal : 0~0.8V ; Abnormal : Open Collector (Recommend Pull high R > 10K, VDD = 3.3V)
12	VLON	BL On-Off: High/Open (2.0V~5.5V) for BL On, Low (GND) for off
13	NC	NC
14	PDIM(*)	External PWM (5%~100% Duty, open for 100%)

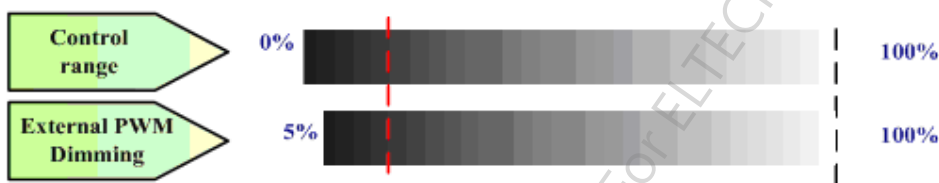

PWM Dimming : include Internal and External PWM Dimming

(Note*) IF External PWM function includes 5% dimming ratio. Judge condition as below:

- (1) Backlight module must be lighted ON normally.
- (2) All protection function must work normally.

Uniformity and flicker could NOT be guaranteed

3.7.3 Power Sequence for Backlight (CCFL and LED)

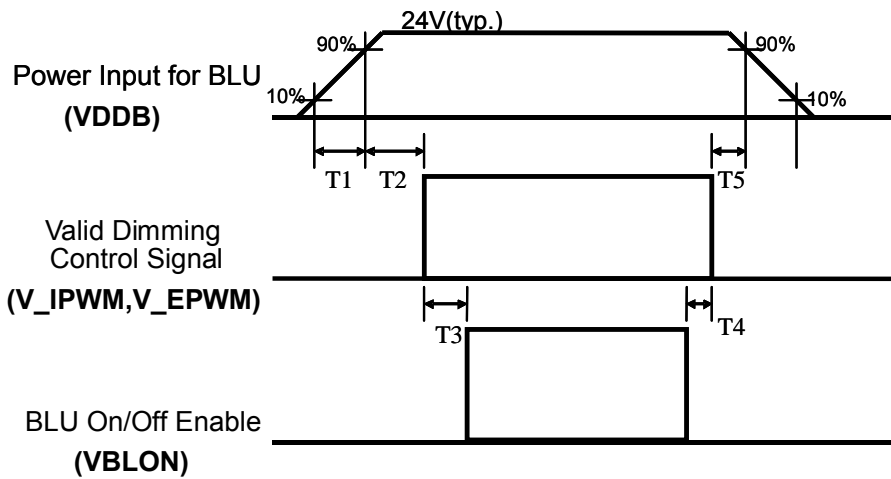

Dip condition

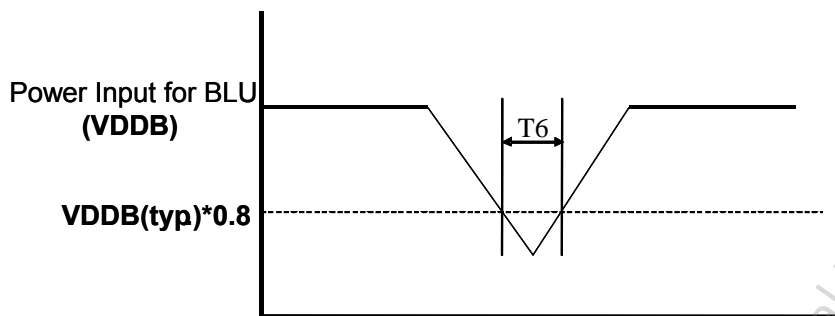

Parameter	Value			Units
	Min	Typ	Max	
T1	20	-	-	ms
T2	250	-	-	ms
T3	200	-	-	ms
T4	0	-	-	ms
T5	0	-	-	ms
T6	-	-	1000	ms ^{*1}

Note:1. T6 describes VDDB dip condition and VDDB couldn't lower than 10% VDDB.

4. Optical Specification

Optical characteristics are determined after the unit has been 'ON' and stable for approximately 45 minutes in a dark environment at 25°C. The values specified are at an approximate distance 50cm from the LCD surface at a viewing angle of ϕ and θ equal to 0°.

Fig.1 presents additional information concerning the measurement equipment and method.

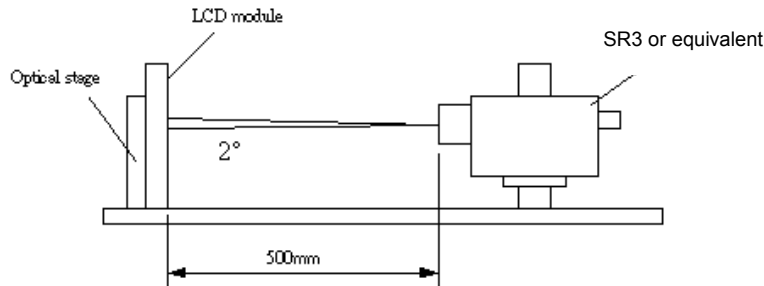

Parameter	Symbol	Values			Unit	Notes
		Min.	Typ.	Max		
Contrast Ratio	CR	3200	4000	--		1
Surface Luminance (White)	L _{WH} (2D)	360	450	--	cd/m ²	2
Luminance Variation	$\delta_{\text{WHITE}(9P)}$	--	--	1.33		3
Response Time (G to G)	T _γ	--	8	--	ms	4
Color Gamut	NTSC		72		%	
Color Coordinates						
Red	R _x	Typ.-0.03	0.640	Typ.+0.03		
	R _y		0.330			
Green	G _x		0.300			
	G _y		0.600			
Blue	B _x		0.150			
	B _y		0.050			
White	W _x		0.280			
	W _y		0.290			
Viewing Angle						
x axis, right($\phi=0^\circ$)	θ_r	--	89	--	degree	5
x axis, left($\phi=180^\circ$)	θ_l	--	89	--	degree	
y axis, up($\phi=90^\circ$)	θ_u	--	89	--	degree	
y axis, down ($\phi=270^\circ$)	θ_d	--	89	--	degree	

Note:

1. Contrast Ratio (CR) is defined mathematically as:

$$\text{Contrast Ratio} = \frac{\text{Surface Luminance of } L_{on5}}{\text{Surface Luminance of } L_{off5}}$$

2. Surface luminance is luminance value at point 5 across the LCD surface 50cm from the surface with all pixels displaying white. From more information see FIG 2. LED current I_F = typical value (without driver board), LED input $V_{DDB} = 24V$, I_{DDB} = Typical value (with driver board), $L_{WH} = L_{on5}$ where L_{on5} is the luminance with all pixels displaying white at center 5 location.

3. The variation in surface luminance, δ_{WHITE} is defined (center of Screen) as:

$$\delta_{WHITE(9P)} = \text{Maximum}(L_{on1}, L_{on2}, \dots, L_{on9}) / \text{Minimum}(L_{on1}, L_{on2}, \dots, L_{on9})$$

4. Response time T is the average time required for display transition by switching the input signal for five luminance ratio (0%,25%,50%,75%,100% brightness matrix) and is based on $F_v = 60\text{Hz}$ to optimize.

Measured Response Time		Target				
		0%	25%	50%	75%	100%
Start	0%		0% to 25%	0% to 50%	0% to 75%	0% to 100%
	25%	25% to 0%		25% to 50%	25% to 75%	25% to 100%
	50%	50% to 0%	50% to 25%		50% to 75%	50% to 100%
	75%	75% to 0%	75% to 25%	75% to 50%		75% to 100%
	100%	100% to 0%	100% to 25%	100% to 50%	100% to 75%	

T is determined by 10% to 90% brightness difference of rising or falling period. (As illustrated)

The response time is defined as the following figure and shall be measured by switching the input signal for "any level of gray(bright)" and "any level of gray(dark)".

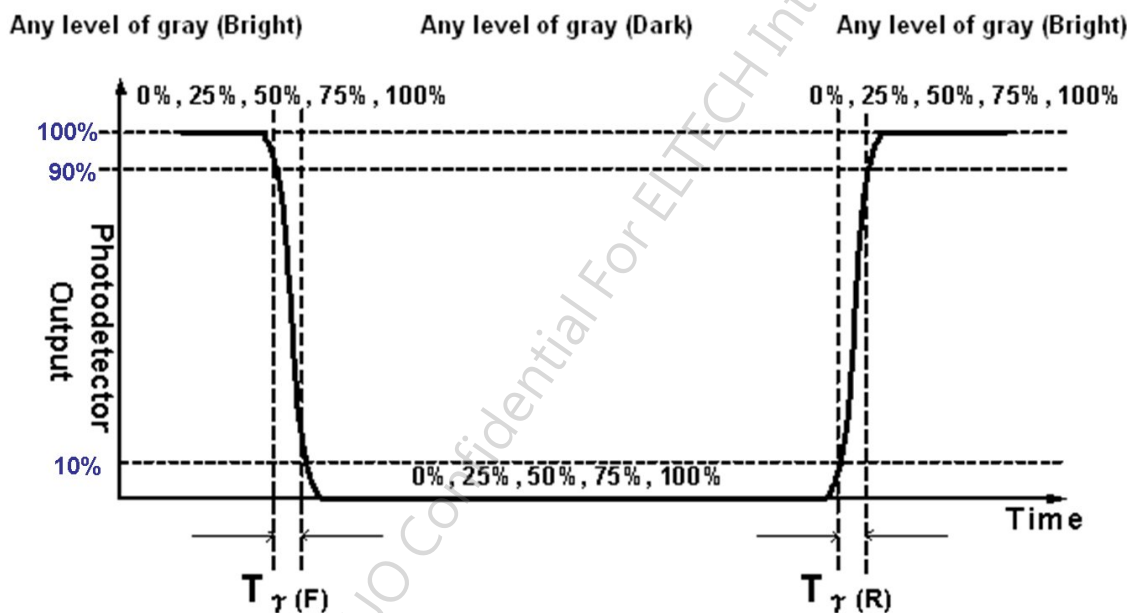
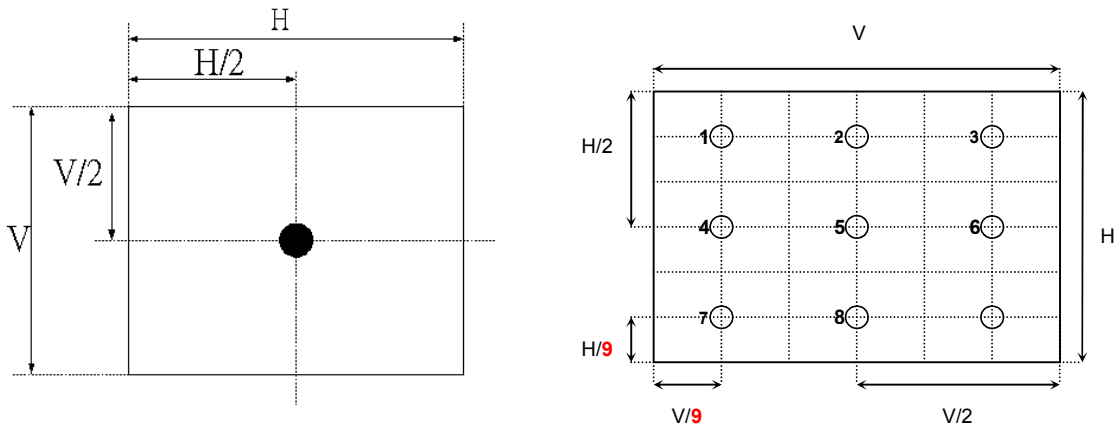
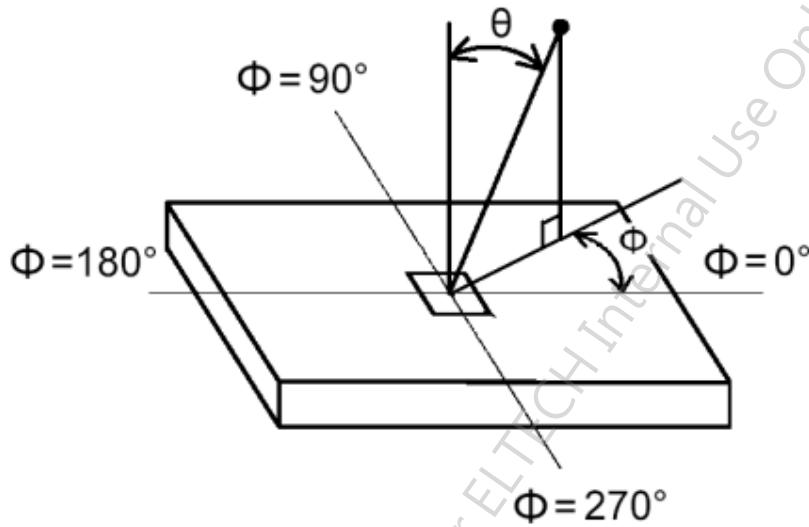

FIG. 2 Luminance



- Viewing angle is the angle at which the contrast ratio is greater than 10. The angles are determined for the horizontal or x axis and the vertical or y axis with respect to the z axis which is normal to the LCD surface. For more information see FIG3.



5. Mechanical Characteristics

The contents provide general mechanical characteristics for the model P750QVN01.0 In addition the figures in the next page are detailed mechanical drawing of the LCD.

Item	Dimension	Unit	Note	
Outline Dimension	Horizontal	1675.8	mm	
	Vertical	953.8	mm	
	Depth (Dmin)	25	mm	front bezel to back bezel
	Depth (Dmax)	47.4	mm	front bezel to driver board cover
Weight	34000	G	w/ DB	

5.7 Placement Suggestions

1. Landscape Mode: The default placement is T-Con Side on the **lower** side and the image is shown upright via viewing from the front.
2. Portrait Mode: The default placement is that T-Con side has to be placed on the **left** side via viewing from the front.

Landscape (Front view)

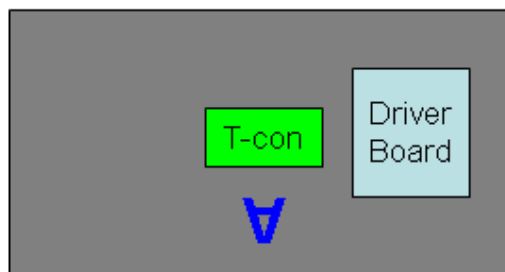

Portrait (Front view)

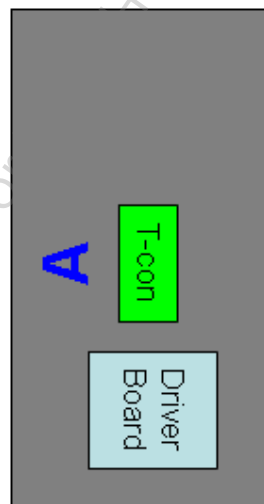

Front View

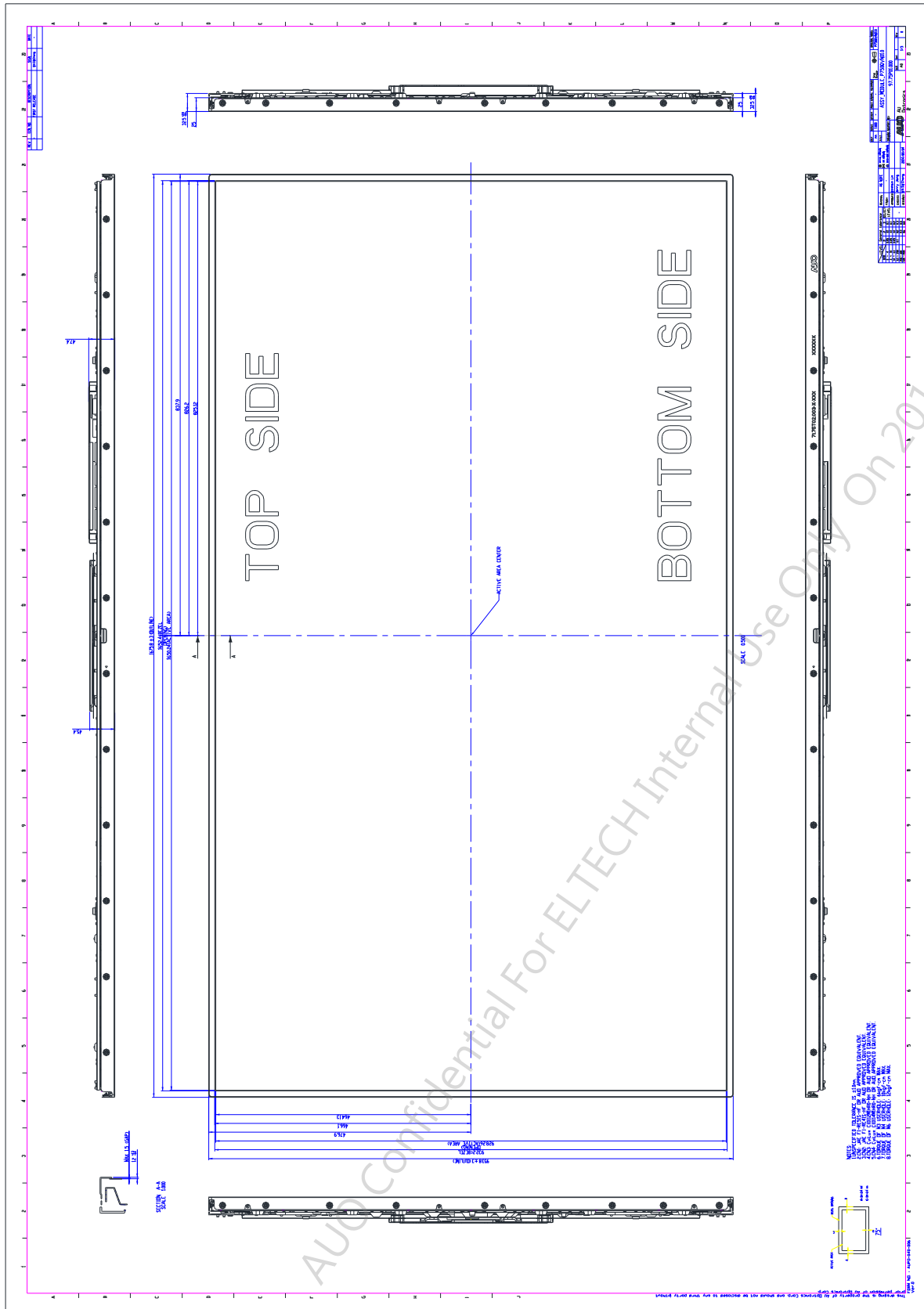

Back View

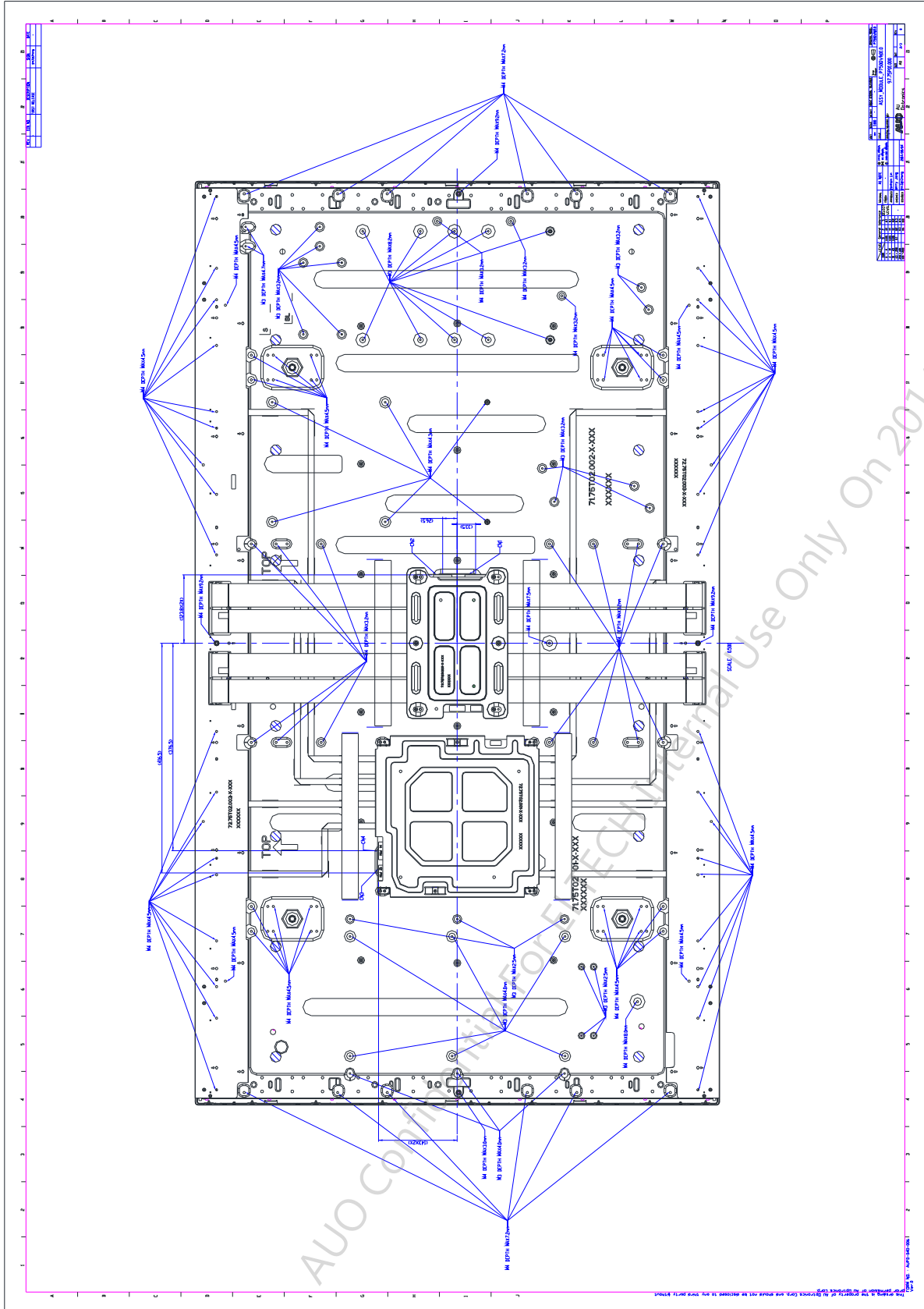

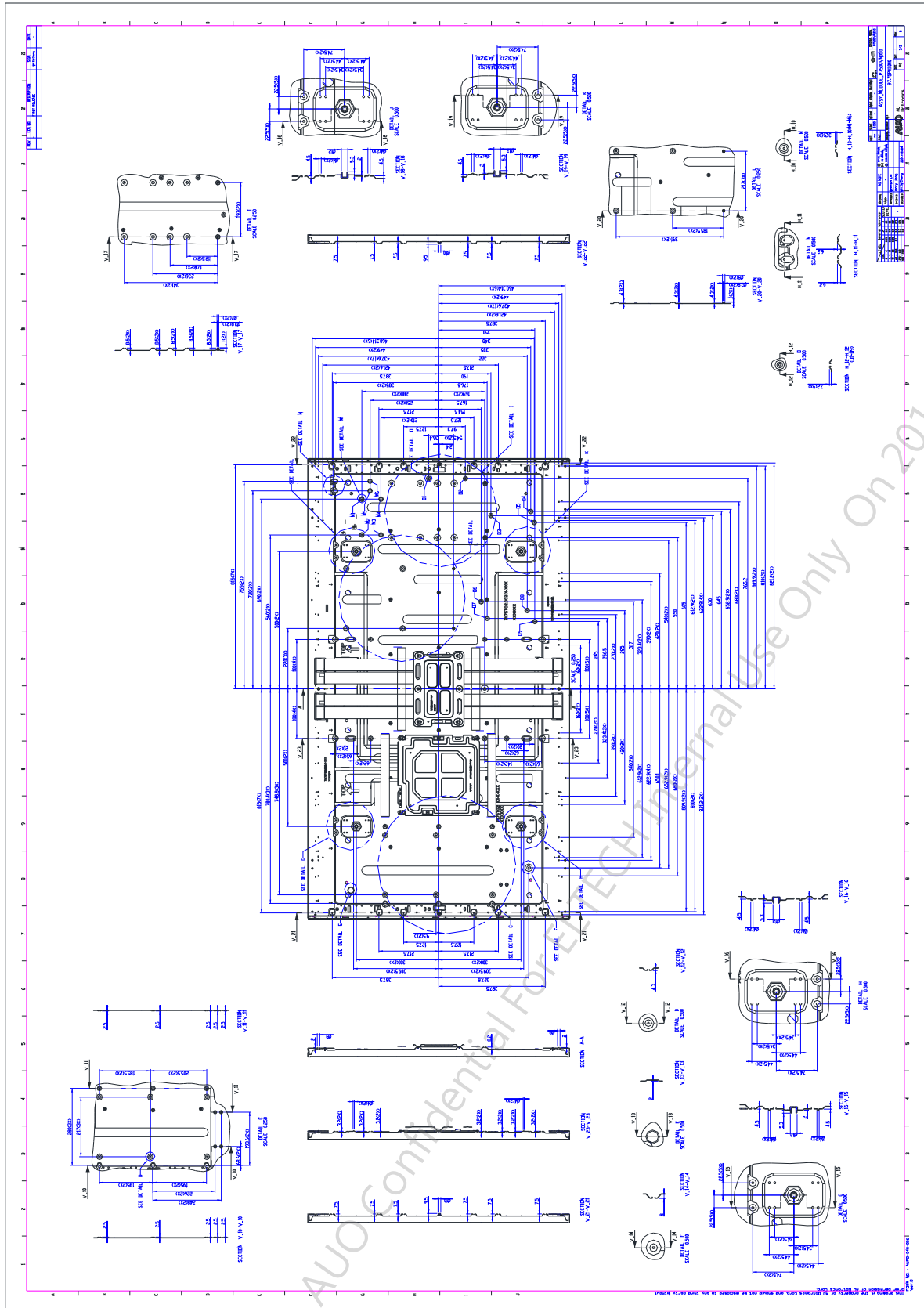

6. Reliability Test Items

	Test Item	Q'ty	Condition
1	High temperature storage test	3	60 , 500hrs
2	Low temperature storage test	3	-20 , 500hrs
3	High temperature operation test	3	50 , 500hrs
4	Low temperature operation test	3	-5 , 500hrs
5	Vibration test (With carton)	1(PKG)	Random wave (1.04Grms 2~200Hz) Duration : X,Y,Z 20min per axes
6	Drop test (With carton)	1(PKG)	Height: 25.4 cm Direction: Only bottom flat twice (ASTMD4169-I)

AUO Confidential For ELTECH Internal Use Only On 2014/10/08

7. International Standard

7.1 Safety

- (1) UL 60950-1; Standard for Safety of Information Technology Equipment Including electrical Business Equipment.
- (2) IEC 60950-1; Standard for Safety of International Electrotechnical Commission
- (3) EN 60950-1; European Committee for Electrotechnical Standardization (CENELEC), EUROPEAN STANDARD for Safety of Information Technology Equipment Including Electrical Business Equipment.

7.2 EMC

- (1) ANSI C63.4 "Methods of Measurement of Radio-Noise Emissions from Low-Voltage Electrical and Electrical Equipment in the Range of 9kHz to 40GHz." American National standards Institute(ANSI), 1992
- (2) C.I.S.P.R "Limits and Methods of Measurement of Radio Interface Characteristics of Information Technology Equipment." International Special committee on Radio Interference.
- (3) EN 55022 "Limits and Methods of Measurement of Radio Interface Characteristics of Information Technology Equipment." European Committee for Electrotechnical Standardization. (CENELEC), 1998



8. Packing

8.1 Definition of Label

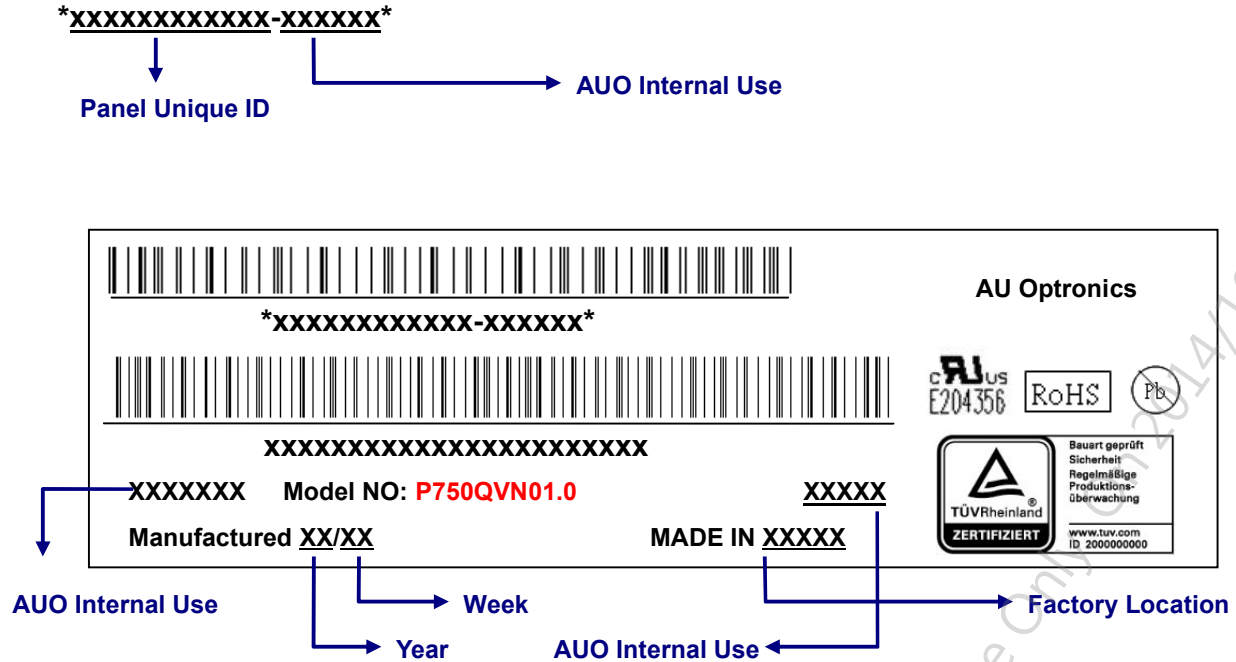
A. Panel Label:



Green mark description

- (1) For Pb Free Product, AUO will add  for identification.
- (2) For RoHs compatible products, AUO will add  for identification.

Note: The green Mark will be present only when the green documents have been ready by AUO internal green team. (definition of green design follows the AUO green design checklist.)

B. Carton Label:

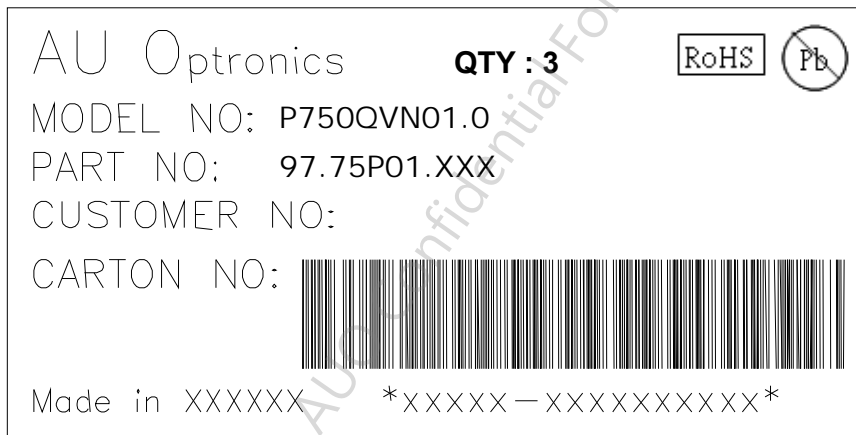

8.2 Pallet and Shipment Information

	Item	Specification			Packing Remark
		Qty.	Dimension	Weight (kg)	
1	Packing Box	3 pcs/box	1870(L)mm*380*(W)mm*1075(H)mm	120	
2	Pallet	1	1900(L)mm*1150(W)mm*150(H)mm	15	
3	Boxes per Pallet	3 boxes/Pallet (By Air) ; 3 Boxes/Pallet (By Sea)			
4	Panels per Pallet	9 pcs/pallet(By Air) ; 9 pcs/Pallet (By Sea)			
5	Pallet after packing	9pcs(by Air)	1900(L)mm*1150(W)mm*1225 (H)mm	135	

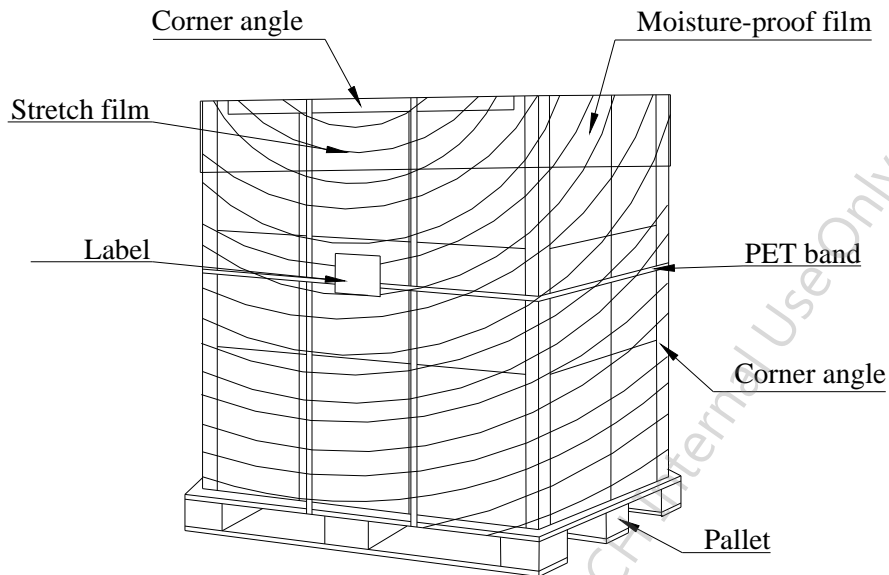

9. Precautions

Please pay attention to the followings when you use this TFT LCD module.

9.1 Mounting Precautions

- (1) You must mount a module using holes arranged in four corners or four sides.
- (2) You should consider the mounting structure so that uneven force (ex. twisted stress) is not applied to module. And the case on which a module is mounted should have sufficient strength so that external force is not transmitted directly to the module.
- (3) Please attach the surface transparent protective plate to the surface in order to protect the polarizer. Transparent protective plate should have sufficient strength in order to resist external force.
- (4) You should adopt radiation structure to satisfy the temperature specification.
- (5) Acetic acid type and chlorine type materials for the cover case are not desirable because the former generates corrosive gas of attacking the polarizer at high temperature and the latter cause circuit broken by electro-chemical reaction.
- (6) Do not touch, push or rub the exposed polarizer with glass, tweezers or anything harder than HB pencil lead. And please do not rub with dust clothes with chemical treatment. Do not touch the surface of polarizer for bare hand or greasy cloth. (Some cosmetics are detrimental to the polarizer.)
- (7) When the surface becomes dusty, please wipe gently with absorbent cotton or other soft materials like chamois soaks with petroleum benzene. Normal-hexane is recommended for cleaning the adhesives used to attach front/ rear polarizer. Do not use acetone, toluene and alcohol because they cause chemical damage to the polarizer.
- (8) Wipe off saliva or water drops as soon as possible. Their long time contact with polarizer causes deformations and color fading.
- (9) Do not open the case because inside circuits do not have sufficient strength.

9.2 Operating Precautions

- (1) The spike noise causes the mis-operation of circuits. It should be lower than following voltage:
 $V = \pm 200\text{mV}$ (Over and under shoot voltage)
- (2) Response time depends on the temperature. (In lower temperature, it becomes longer..)
- (3) Brightness depends on the temperature. (In lower temperature, it may become lower.) And in lower temperature, response time (required time that brightness is stable after turned on) becomes longer.
- (4) Be careful for condensation at sudden temperature change. Condensation makes damage to polarizer or electrical contacted parts. And after fading condensation, smear or spot will occur.
- (5) When fixed patterns are displayed for a long time, remnant image is likely to occur.
- (6) Module has high frequency circuits. Sufficient suppression to the electromagnetic interference shall be done by system manufacturers. Grounding and shielding methods may be important to minimize the interface.

9.3 Operating Condition for Public Information Display

The device listed in the product specification is designed and manufactured for PID (Public Information Display) application. To optimize module's lifetime and function, below operating usages are required.

(1) Normal operating condition

- A. Operating temperature: 5~40
- B. Operating humidity: 10~90%
- C. Display pattern: dynamic pattern (Real display).

Note) Long-term static display would cause image sticking.

(2) Operation usage to protect against abnormal display due to long-term static display.

- A. Suitable operating time: under **14** hours a day.
- B. Liquid Crystal refresh time is required. Cycling display between 5 minutes' information (static) display and 10 seconds' moving image.
- C. Periodically change background and character (image) color.
- D. Avoid combination of background and character with large different luminance.

(3) Periodically adopt one of the following actions after long time display.

- A. Running the screen saver (motion picture or black pattern)
- B. Power off the system for a while

(4) LCD system is required to place in well-ventilated environment. Adapting active cooling system is highly recommended.

(5) Product reliability and functions are only guaranteed when the product is used under right operation usages. If product will be used in extreme conditions, such as high temperature/humidity, display stationary patterns, or long operation time etc..., it is strongly recommended to contact AUO for filed application engineering advice. Otherwise, its reliability and function may not be guaranteed. Extreme conditions are commonly found at airports, transit stations, banks, stock market and controlling systems.

9.4 Electrostatic Discharge Control

Since a module is composed of electronic circuits, it is not strong to electrostatic discharge. Make certain that treatment persons are connected to ground through wristband etc. And don't touch interface pin directly.

9.5 Precautions for Strong Light Exposure

Strong light exposure causes degradation of polarizer and color filter.

9.6 Storage

When storing modules as spares for a long time, the following precautions are necessary.

- (1) Store them in a dark place. Do not expose the module to sunlight or fluorescent light. Keep the temperature between 5 and 35 at normal humidity.

- (2) The polarizer surface should not come in contact with any other object. It is recommended that they be stored in the container in which they were shipped.
- (3) Storage condition is guaranteed under packing conditions.
- (4) The phase transition of Liquid Crystal in the condition of the low or high storage temperature will be recovered when the LCD module returns to the normal condition.

9.7 Handling Precautions for Protection Film

- (1) The protection film is attached to the bezel with a small masking tape. When the protection film is peeled off, static electricity is generated between the film and polarizer. This should be peeled off slowly and carefully by people who are electrically grounded and with well ion-blown equipment or in such a condition, etc.
- (2) When the module with protection film attached is stored for a long time, sometimes there remains a very small amount of glue still on the bezel after the protection film is peeled off.
- (3) You can remove the glue easily. When the glue remains on the bezel or its vestige is recognized, please wipe them off with absorbent cotton waste or other soft material like chamois soaked with normal-hexane.

AUO Confidential For ELTECH Internal Use Only On 2014/10/08