

P8008HVA

Dual N-Channel Enhancement Mode MOSFET

PRODUCT SUMMARY

$V_{(BR)DSS}$	$R_{DS(ON)}$	I_D
80V	68mΩ @ $V_{GS} = 10V$	3.2A

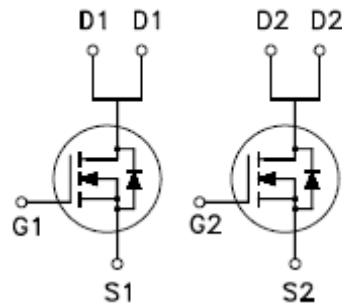
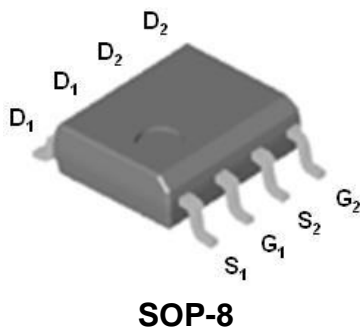

ABSOLUTE MAXIMUM RATINGS ($T_A = 25\text{ °C}$ Unless Otherwise Noted)

PARAMETERS/TEST CONDITIONS		SYMBOL	LIMITS	UNITS
Drain-Source Voltage		V_{DS}	80	V
Gate-Source Voltage		V_{GS}	±25	
Continuous Drain Current	$T_A = 25\text{ °C}$	I_D	3.2	A
	$T_A = 70\text{ °C}$		2.5	
Pulsed Drain Current ¹		I_{DM}	18	
Avalanche Current		I_{AS}	15.8	
Avalanche Energy	$L = 0.1\text{mH}$	E_{AS}	12.5	mJ
Power Dissipation	$T_A = 25\text{ °C}$	P_D	1.5	W
	$T_A = 70\text{ °C}$		1	
Operating Junction & Storage Temperature Range		T_j, T_{stg}	-55 to 150	°C

THERMAL RESISTANCE RATINGS

THERMAL RESISTANCE	SYMBOL	TYPICAL	MAXIMUM	UNITS
Junction-to-Lead	$R_{\theta JL}$		25	°C / W
Junction-to-Ambient	$R_{\theta JA}$		80	

¹Pulse width limited by maximum junction temperature.

P8008HVA

Dual N-Channel Enhancement Mode MOSFET

ELECTRICAL CHARACTERISTICS (T_J = 25 °C, Unless Otherwise Noted)

PARAMETER	SYMBOL	TEST CONDITIONS	LIMITS			UNITS
			MIN	TYP	MAX	
STATIC						
Drain-Source Breakdown Voltage	V _{(BR)DSS}	V _{GS} = 0V, I _D = 250μA	80			V
Gate Threshold Voltage	V _{GS(th)}	V _{DS} = V _{GS} , I _D = 250μA	1	1.9	3	
Gate-Body Leakage	I _{GSS}	V _{DS} = 0V, V _{GS} = ±25V			±100	nA
Zero Gate Voltage Drain Current	I _{DSS}	V _{DS} = 64V, V _{GS} = 0V			1	μA
		V _{DS} = 64V, V _{GS} = 0V, T _J = 70 °C			10	
Drain-Source On-State Resistance ¹	R _{DS(ON)}	V _{GS} = 10V, I _D = 3A		44	68	mΩ
		V _{GS} = 4.5V, I _D = 1A		47	78	
Forward Transconductance ¹	g _{fs}	V _{DS} = 10V, I _D = 3A		17		S
DYNAMIC						
Input Capacitance	C _{iss}	V _{GS} = 0V, V _{DS} = 25V, f = 1MHz		576		pF
Output Capacitance	C _{oss}			63		
Reverse Transfer Capacitance	C _{rss}			42		
Gate Resistance	R _g	V _{GS} = 0V, V _{DS} = 0V, f = 1MHz		1.2		Ω
Total Gate Charge ²	Q _g	V _{DS} = 80V, V _{GS} = 10V, I _D = 3A		15		nC
Gate-Source Charge ²	Q _{gs}			2		
Gate-Drain Charge ²	Q _{gd}			5		
Turn-On Delay Time ²	t _{d(on)}	V _{DS} = 40V, I _D ≅ 3A, V _{GS} = 10V, R _G = 6Ω		14		nS
Rise Time ²	t _r			6		
Turn-Off Delay Time ²	t _{d(off)}			38		
Fall Time ²	t _f			8		
SOURCE-DRAIN DIODE RATINGS AND CHARACTERISTICS						
Continuous Current	I _S				1.1	A
Forward Voltage ¹	V _{SD}	I _F = 3A, V _{GS} = 0V			1.3	V
Reverse Recovery Time	t _{rr}	I _F = 3A, dI _F /dt = 100A / μS		30		nS
Reverse Recovery Charge	Q _{rr}			40		nC

¹Pulse test : Pulse Width ≤ 300 μsec, Duty Cycle ≤ 2%.

²Independent of operating temperature.

³Pulse width limited by maximum junction temperature.

P8008HVA

Dual N-Channel Enhancement Mode MOSFET

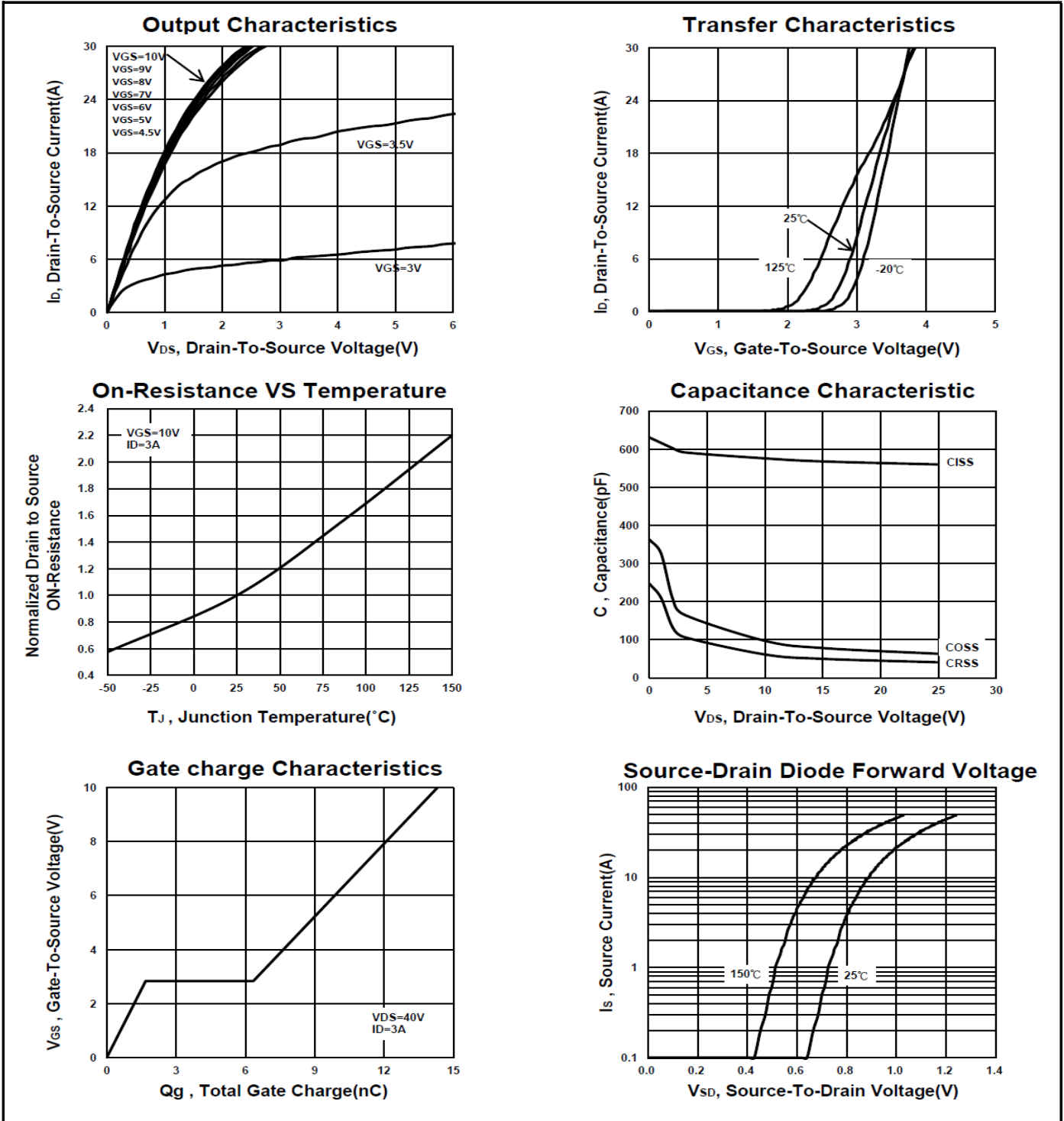

P8008HVA

Dual N-Channel Enhancement Mode MOSFET

Safe Operating Area

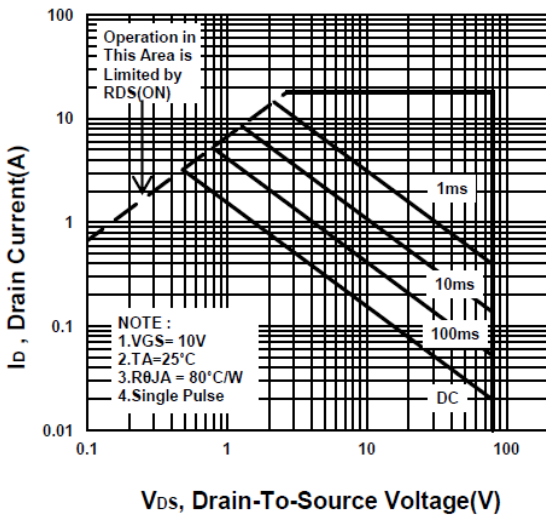

Single Pulse Maximum Power Dissipation

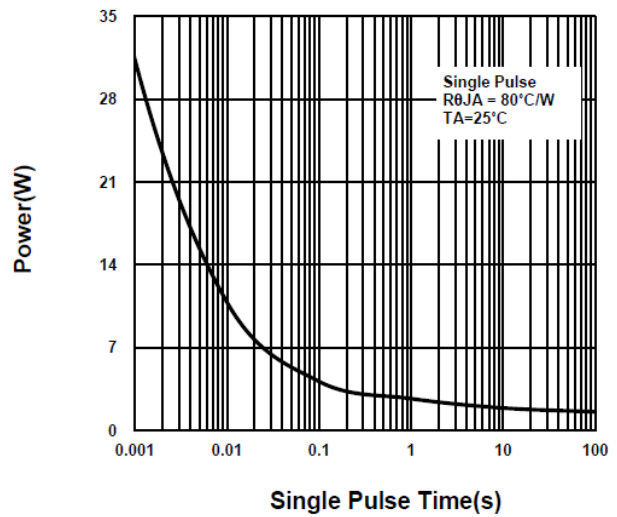

Transient Thermal Response Curve

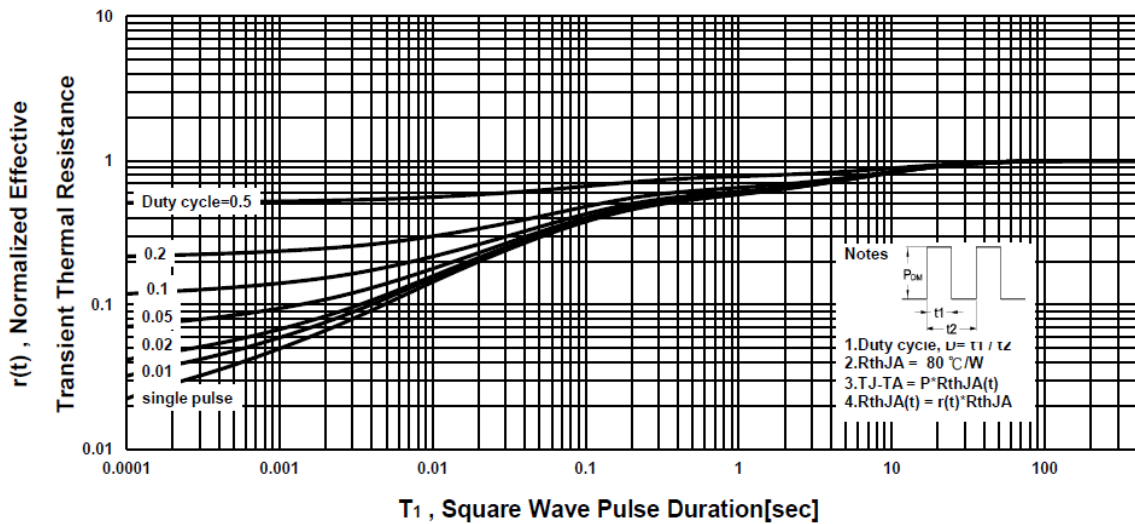

P8008HVA

Dual N-Channel Enhancement Mode MOSFET

Package Dimension

SOP-8 MECHANICAL DATA

Dimension	mm			Dimension	mm		
	Min.	Typ.	Max.		Min.	Typ.	Max.
A	4.8	4.9	5.0	H	0.4	0.6	0.93
B	3.8	3.9	4.0	I	0.19	0.21	0.25
C	5.79	6.0	6.2	J	0.25	0.375	0.5
D	0.33	0.4	0.51	K	0°	3°	18°
E	1.25	1.27	1.29				
F	1.1	1.3	1.65				
G	0.05	0.15	0.25				

