

FEATURES

- **LOW COST**
- **WIDE COMMON MODE RANGE** — Includes negative supply
- **WIDE SUPPLY VOLTAGE RANGE**
Single supply: 5V to 40V
Split supplies: $\pm 2.5V$ to $\pm 20V$
- **HIGH EFFICIENCY** — $|V_s - 2.2V|$ at 2.5A typ
- **HIGH OUTPUT CURRENT** — 3A min (PA21A)
- **INTERNAL CURRENT LIMIT**
- **LOW DISTORTION**

APPLICATIONS

- **HALF & FULL BRIDGE MOTOR DRIVERS**
- **AUDIO POWER AMPLIFIER**
STEREO — 18W RMS per channel
BRIDGE — 36W RMS per package
- **IDEAL FOR SINGLE SUPPLY SYSTEMS**
5V — Peripherals
12V — Automotive
28V — Avionic

DESCRIPTION

The amplifiers consist of a monolithic dual power op amp in a 8-pin hermetic TO-3 package (PA21 and PA25) and a 12-pin SIP package (PA26). Putting two power op amps in one package and on one die results in an extremely cost effective solution for applications requiring multiple amplifiers per board or bridge mode configurations.

The wide common mode input range includes the negative rail, facilitating single supply applications. It is possible to have a “ground based” input driving a single supply amplifier with ground acting as the “second” or “bottom” supply of the amplifier.

The output stages are also well protected. They possess internal current limit circuits. While the device is well protected, the Safe Operating Area (SOA) curve must be observed. Proper heatsinking is required for maximum reliability.

This hybrid integrated circuit utilizes thick film (cermet) resistors, ceramic capacitors and semiconductor chips to maximize reliability, minimize size and give top performance. Ultrasonically bonded aluminum wires provide reliable interconnections at all operating temperatures. The 8-pin TO-3 package is hermetically sealed and electrically isolated. The use of compressible isolation washers voids the warranty. The tab of the SIP12 plastic package is tied to $-V_s$.

TYPICAL APPLICATION

R1 and R2 set up amplifier A in a non-inverting gain of 2.8. Amp B is set up as a unity gain inverter driven from the output of amp A. Note that amp B inverts signals about the reference node, which is set at mid-supply (14V) by R5 and R6. When the command input is 5V, the output of amp A is 14V. Since this is equal to the reference node voltage, the output of amp B is also 14V, resulting in 0V across the motor. Inputs more positive than 5V result in motor current flow from left to right (see Figure 1). Inputs less positive than 5V drive the motor in the opposite direction.

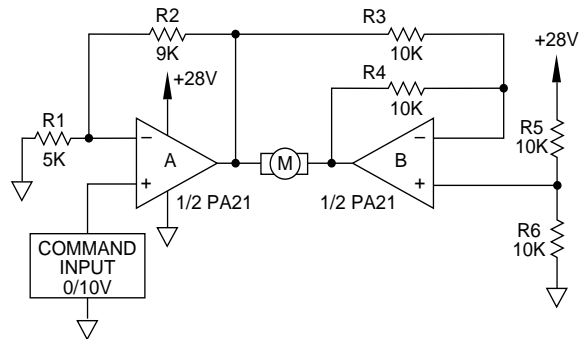
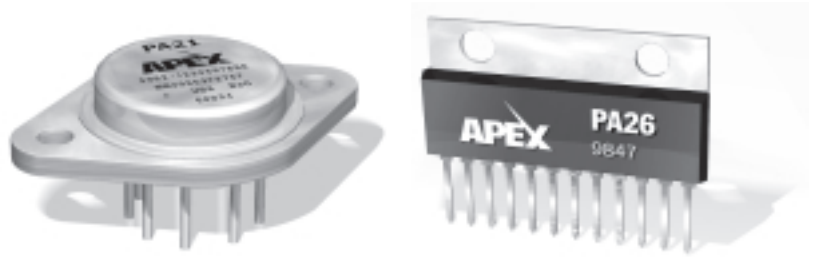

FIGURE 1: BIDIRECTIONAL SPEED CONTROL FROM A SINGLE SUPPLY

The amplifiers are especially well-suited for this application. The extended common mode range allows common inputs as low as 0V. Its superior output swing abilities let it drive within 2V of supply at an output current of 2A. This means that a command input that ranges from 0V to 10V will drive a 24V motor from full scale CCW to full scale CW at up to $\pm 2A$. A single power op amp with an output swing capability of $V_s - 6$ would require $\pm 30V$ supplies and would be required to swing 48V p-p at twice the speed to deliver an equivalent drive.

EXTERNAL CONNECTIONS

PA26

Connect pins 3 and 10 to pin 7 and connect pins 4 and 9 to pin 6 unless special functions are required.

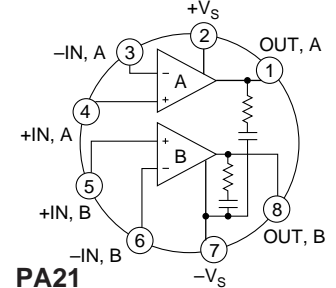
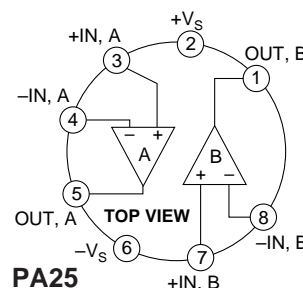
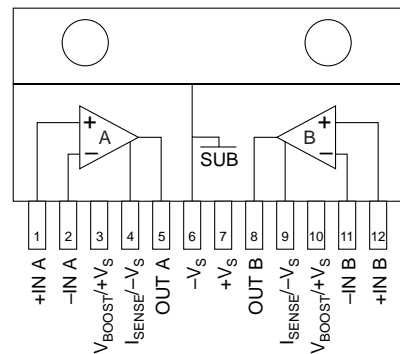

PA21/25/26 • PA21A/25A

ABSOLUTE MAXIMUM RATINGS
SPECIFICATIONS

ABSOLUTE MAXIMUM RATINGS

SUPPLY VOLTAGE, total	5V to 40V
OUTPUT CURRENT	SOA
POWER DISSIPATION, internal (per amplifier)	25W
POWER DISSIPATION, internal (both amplifiers)	36W
INPUT VOLTAGE, differential	$\pm V_S$
INPUT VOLTAGE, common mode	$+V_S, -V_S-.5V$
JUNCTION TEMPERATURE, max ¹	150°C
TEMPERATURE, pin solder—10 sec max	300°C
TEMPERATURE RANGE, storage	-65°C to 150°C
OPERATING TEMPERATURE RANGE, case	-55°C to 125°C

SPECIFICATIONS

PARAMETER	TEST CONDITIONS ²	PA21/25/26			PA21A/PA25A			UNITS
		MIN	TYP	MAX	MIN	TYP	MAX	
INPUT								
OFFSET VOLTAGE, initial			1.5	10		.5	4	mV
OFFSET VOLTAGE, vs. temperature	Full temperature range		15			10		$\mu V/^\circ C$
BIAS CURRENT, initial			35	1000		*	250	nA
COMMON MODE RANGE	Full temperature range	$-V_S-.3$		$+V_S-2$	*		*	V
COMMON MODE REJECTION, DC	Full temperature range	60	85		*	*		dB
POWER SUPPLY REJECTION	Full temperature range	60	80		*	*		dB
CHANNEL SEPARATION	$I_{OUT} = 1A, F = 1kHz$	50	68		*	*		dB
GAIN								
OPEN LOOP GAIN	Full temperature range	80	100		*	*		dB
GAIN BANDWIDTH PRODUCT	$A_v = 40dB$		600			*		kHz
PHASE MARGIN	Full temperature range		65			*		°
POWER BANDWIDTH	$V_{O(P-P)} = 28V$		13.6			*		kHz
OUTPUT								
CURRENT, peak		2.5			3			A
CURRENT, limit			3.0			4.0		A
SLEW RATE		.5	1.2		*	*		V/ μs
CAPACITIVE LOAD DRIVE	$A_v = 1$.22			*		μF
VOLTAGE SWING	Full temp. range, $I_O = 100mA$	$ V_S - 1.0$	$ V_S - 0.8$		*	*		V
VOLTAGE SWING	Full temp. range, $I_O = 1A$	$ V_S - 1.8$	$ V_S - 1.4$		*	*		V
VOLTAGE SWING	$I_O = 2.5A$ (PA21, 25)	$ V_S - 3.0$	$ V_S - 2.8$					V
VOLTAGE SWING	$I_O = 3.0A$ (PA21A, PA25A)				$ V_S - 4.0$	$ V_S - 3.5$		V
POWER SUPPLY								
VOLTAGE, V_{SS}^3		5 ⁴	30	40	*	*	*	V
CURRENT, quiescent, total			45	90		*	*	mA
THERMAL								
RESISTANCE, junction to case								
DC, single amplifier			5.0			*		$^\circ C/W$
DC, both amplifiers ⁵			3.4			*		$^\circ C/W$
AC, single amplifier			3.7					$^\circ C/W$
AC, both amplifiers ⁵			2.4					$^\circ C/W$
RESISTANCE, junction to air			30			*		$^\circ C/W$
TEMPERATURE RANGE, case	Meets full range specifications	-25		85	-25		85	$^\circ C$

- NOTES: * The specification of PA21A/PA25A is identical to the specification for PA21/PA25 in applicable column to the left.
1. Long term operation at the maximum junction temperature will result in reduced product life. Derate internal power dissipation to achieve high MTTF.
 2. Unless otherwise noted, the following conditions apply: $\pm V_S = \pm 15V, T_C = 25^\circ C$.
 3. $+V_S$ and $-V_S$ denote the positive and negative supply rail respectively. V_{SS} denotes the total rail-to-rail supply voltage.
 4. Current limit may not function properly below $V_{SS} = 6V$, however SOA violations are unlikely in this area.
 5. Rating applies when power dissipation is equal in the two amplifiers.

CAUTION

The internal substrate contains beryllia (BeO). Do not break the seal. If accidentally broken, do not crush, machine, or subject to temperatures in excess of 850°C to avoid generating toxic fumes. (PA21 and PA25 only. PA26 does not contain BeO).

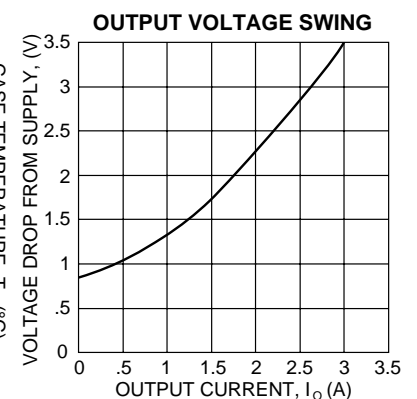
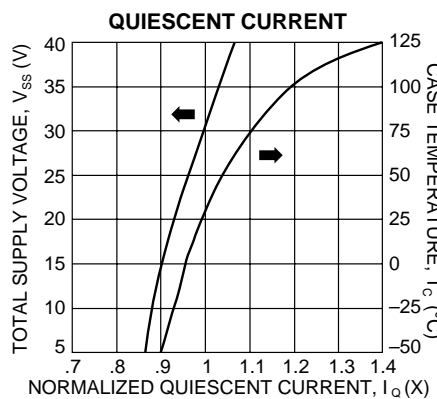
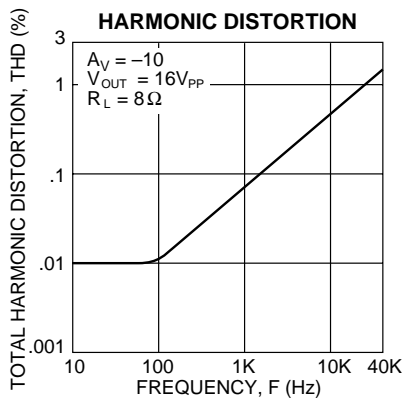
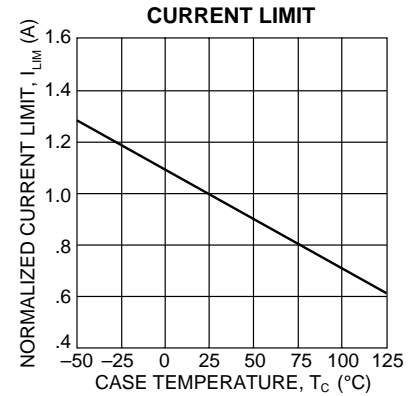
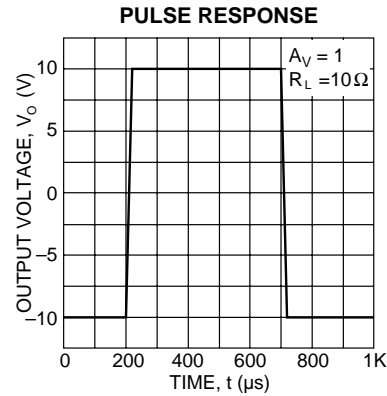
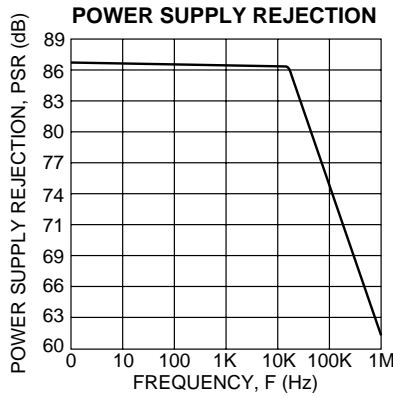
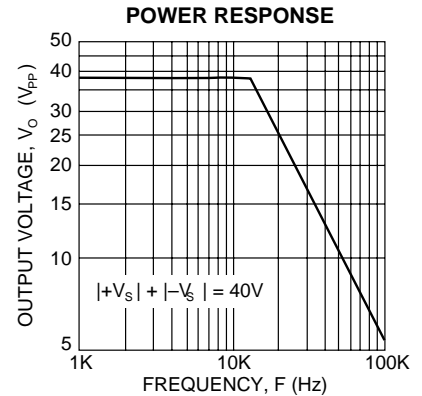
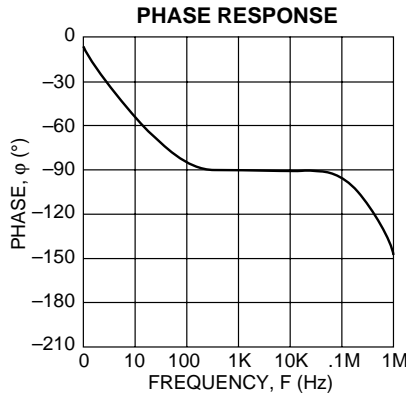
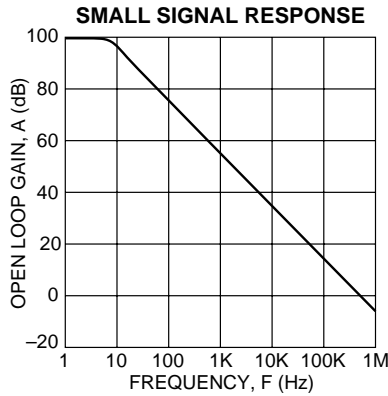
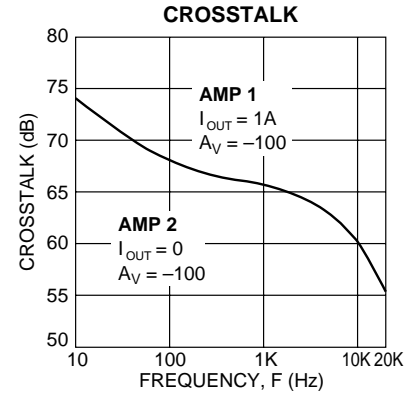
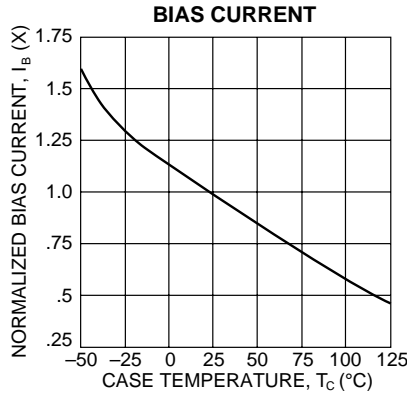
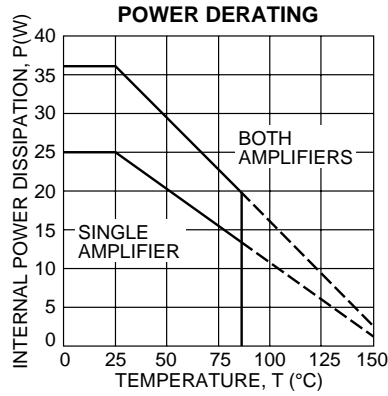

GENERAL

Please read Application Note 1 "General Operating Considerations" which covers stability, supplies, heat sinking, mounting, current limit, SOA interpretation, and specification interpretation. Visit www.apexmicrotech.com for design tools that help automate tasks such as calculations for stability, internal power dissipation, current limit and heat sink selection. The "Application Notes" and "Technical Seminar" sections contain a wealth of information on specific types of applications. Package outlines, heat sinks, mounting hardware and other accessories are located in the "Packages and Accessories" section. Evaluation Kits are available for most Apex product models, consult the "Evaluation Kit" section for details. For the most current version of all Apex product data sheets, visit www.apexmicrotech.com.

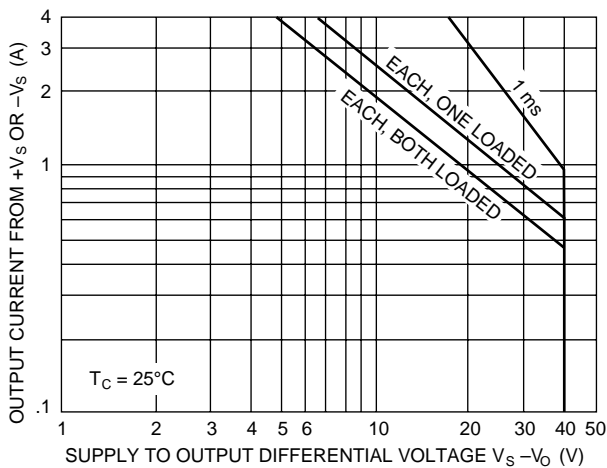

CURRENT LIMIT

Current limit is internal to the amplifier, the typical value is shown in the current limit specification.

SAFE OPERATING AREA (SOA)

The SOA curves combine the effect of all limits for this power op amp. For a given application, the direction and magnitude of the output current should be calculated or measured and checked against the SOA curves. This is simple for resistive loads but more complex for reactive and EMF generating loads. The following guidelines may save extensive analytical efforts.

Under transient conditions, capacitive and dynamic* inductive loads up to the following maximum are safe:

$\pm V_S$	CAPACITIVE LOAD	INDUCTIVE LOAD
20V	200 μF	7.5mH
15V	500 μF	25mH
10V	5mF	35mH
5V	50mF	150mH

* If the inductive load is driven near steady state conditions, allowing the output voltage to drop more than 6V below the supply rail while the amplifier is current limiting, the inductor should be capacitively coupled or the supply voltage must be lowered to meet SOA criteria.

NOTE: For protection against sustained, high energy flyback, external fast-recovery diodes should be used.

MONOLITHIC AMPLIFIER STABILITY CONSIDERATIONS

All monolithic power op amps use output stage topologies that present special stability problems. This is primarily due to non-complementary (both devices are NPN) output stages with a mismatch in gain and phase response for different polarities of output current. It is difficult for the op amp manufacturer to optimize compensation for all operating conditions.

The recommended R-C network of 1 ohm in series with 0.1 μF from output to AC common (ground or a supply rail, with adequate bypass capacitors) will prevent local output stage oscillations.

This network is provided internally on the PA21 but must be supplied externally on the PA25 and PA26. The amplifiers are internally compensated for unity gain stability, no additional compensation is required.

THERMAL CONSIDERATIONS

Although $R_{\theta JC}$ is the same for PA21/25/26 there are differences in the thermal interface between case and heatsink which will limit power dissipation capability. Thermal grease or an Apex TW03 thermal washer, $R_{\theta CS} = .1\text{-}.2^\circ\text{C/W}$, is the only recommended interface for the PA21/25. The PA26 may require a thermal washer which is electrically insulating since the tab is tied to $-V_S$. This can result in thermal impedances for $R_{\theta CS}$ of up to 1°C/W or greater.

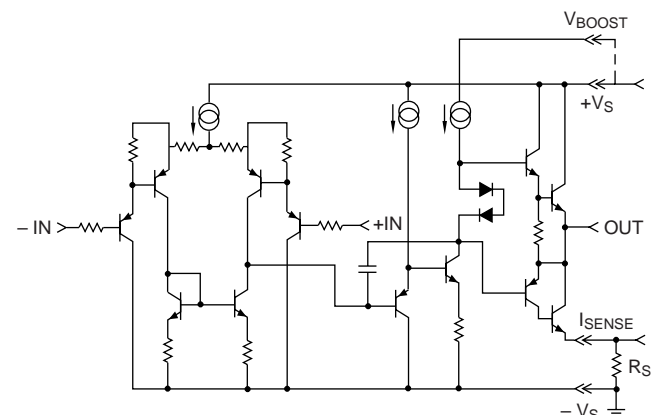

FIGURE 2. PA26 EQUIVALENT SCHEMATIC (ONE CHANNEL)

ADDITIONAL PA26 PIN FUNCTIONS

V_{BOOST}

The V_{BOOST} pin is the positive terminal for the load of the second stage of the amplifier. When that terminal is connected to a voltage greater than +V_S it will provide more drive to the upper output transistor, which is a darlington connected emitter follower. This will better saturate the output transistor.

When V_{BOOST} is about 5 Volts greater than +V_S the positive output can swing 0.5 Volts closer to the rail. This is as much improvement as is possible.

V_{BOOST} pin requires approximately 10–12mA of current. Dynamically it represents 1K Ω impedance. The maximum voltage that can be applied to V_{BOOST} is 40 volts with respect to -V_S. There is no limit to the difference between +V_S and V_{BOOST}.

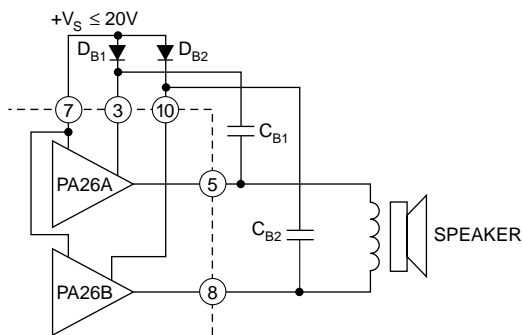

FIGURE 3. SIMPLE BOOTSTRAPPING IMPROVES POSITIVE OUTPUT SWING. CONNECT PINS 3 AND 10 TO V_S IF NOT USED. TYPICAL CURRENTS ARE 12mA EACH.

Figure 3 shows a bootstrap which dynamically couples the output waveform onto the V_{BOOST} pin. This causes V_{BOOST} to swing positive from its initial value, which is equal to +V_S - 0.7 V (one diode drop), an amount equal to the output. In other words, if V_{BOOST} was initially 19.3, and the output swings positive 18 Volts, the voltage on the V_{BOOST} pin will swing to 19.3 - 0.7 + 18 or 36.6. The capacitor needs to be sized based on a 1K Ω impedance and the lowest frequency required by the circuit. For example, 20Hz will require > 8uF.

I_{SENSE}

The I_{SENSE} pin is in series with the negative half of the output stage only. Current will flow through this pin only when negative current is being outputted. The current that flows in this pin is the same current that flows in the output (if -1A flows in the output, the I_{SENSE} pin will have 1A of current flow, if +1A flows in the output the I_{SENSE} pin will have 0 current flow).

The resistor choice is arbitrary and is selected to provide whatever voltage drop the engineer desires, up to a maximum of 1.0 volt. However, any voltage dropped across the resistor will subtract from the swing to rail. For instance, assume a +/- 12 volt power supply and a load that requires +/-1A. With no current sense resistor the output could swing +/-10.2 volts. If a 1 Ω resistor is used for current sense (which will drop 1 Volt at 1 Amp) then the output could swing +10.2, -9.2 Volts.

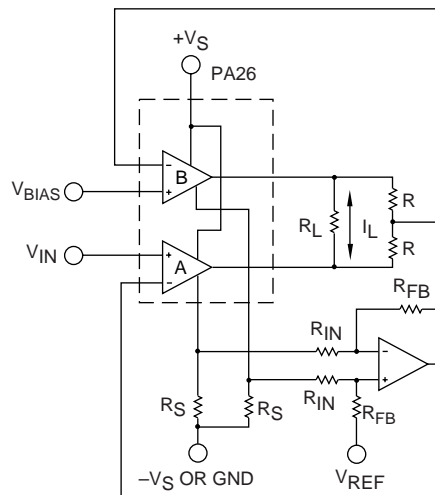

FIGURE 4. I_{SENSE} TRANSCONDUCTANCE BRIDGING AMPLIFIER

Figure 4 shows the PA26 I_{SENSE} feature being used to obtain a Transconductance function. In this example, amplifier "A" is the master and amplifier "B" is the slave. Feedback from sensing resistors R_S is applied to the summing network and scaled to the inverting input of amplifier "A" where it is compared to the input voltage. The current sensing feedback imparts a Transconductance feature to the amplifiers transfer function. In other words, the voltage developed across the sensing resistors is directly proportional to the output current. Using this voltage as a feedback source allows expressing the gain of the circuit in amperes vs input voltage. The transfer function is approximately:

$$I_L = (V_{IN} - V_{REF}) * R_{IN} / R_{FB} / R_S$$

In the illustration, resistors R_{IN}, R_{FB} and R_S determine gain.

V_{BIAS} should be set midway between +V_S and -V_S, V_{ref} is usually ground in dual supply systems or used for level translation in single supply systems.

MOUNTING PRECAUTIONS

1. Always use a heat sink. Even unloaded, the PA26 can dissipate up to 3.6 watts. A thermal washer or thermal grease should always be used.
2. Avoid bending the leads. Such action can lead to internal damage.
3. Always fasten the tab to the heat sink before the leads are soldered to fixed terminals.
4. Strain relief must be provided if there is any probability of axial stress to the leads.