

High Frequency Wire Wound Transformers

EF20 Platforms - THT Type



- AC/DC and DC/DC Switching Transformers
- Reinforced Insulation
- 3000Vrms Hi-pot
- Topology: Flyback
- Custom Design Available

Electrical Specifications @ 25°C - Operating Temperature -40°C to 130°C¹

Model	Parameter	Winding	Value	Notes	Diagram
PF0586NL	Pri. Inductance	(1-4)	1.64 mH NOM.		<p>FLYBACK TRANSFORMER</p>
	Lk. Inductance	w/	$\mu\text{H MAX}$ shorted		
	DCR	(1-4)	2800	m Ω Max	
		(7-8)	17.5		
		(5-6)	7.3		
Hi-Pot	Pri-Sec	4200 Vrms			
K1 Factor		5229.6			
PA2872NL	Pri. Inductance	(2-1)	1800 $\mu\text{H} \pm 10\%$		<p>FLYBACK TRANSFORMER</p>
	Lk. Inductance	(2-1)	42 $\mu\text{H MAX}$ shorted		
	DCR	(2-1)	2020	m Ω Max	
		(5-7)	210		
		(3-4)	510		
Hi-Pot	Pri-Sec	3000 Vrms			
K1 Factor		4687.5			
PA2959NL	Pri. Inductance	(1-2)	380 $\mu\text{H} \pm 20\%$		<p>FLYBACK TRANSFORMER</p>
	Lk. Inductance	(1-2)	5.6 $\mu\text{H MAX}$ shorted		
	DCR	(1-2)	740	m Ω Max	
		(4-3)	1050		
		(5-6)	240		
(7-8)		280			
Hi-Pot	Pri-Sec	3000 Vrms			
K1 Factor		3044.8			
PA2979NL	Pri. Inductance	(1-2)	864 $\mu\text{H} \pm 20\%$		<p>FLYBACK TRANSFORMER</p>
	Lk. Inductance	(1-2)	TBD $\mu\text{H MAX}$ shorted		
	DCR	(1-2)	1000	m Ω Max	
		(4-3)	6800		
		(5-6)	300		
Hi-Pot	Pri-Sec	3000 Vrms			
K1 Factor		2755.1			
PA3072NL	Pri. Inductance	(4-3)	290 $\mu\text{H} \pm 10\%$		<p>FLYBACK TRANSFORMER</p>
	Lk. Inductance	(4-3)	7.4 $\mu\text{H MAX}$ shorted		
	DCR	(4-3)	560	m Ω Max	
		(6-8)	22		
		(2-1)	160		
Hi-Pot	Pri-Sec	3000 Vrms			
K1 Factor		1295			

USA 858 674 8100

Germany 49 7032 7806 0

Singapore 65 6287 8998

Shanghai 86 21 62787060

China 86 755 33966678

Taiwan 886 3 4356768

High Frequency Wire Wound Transformers

EF20 Platforms - THT Type



NOTES:

1. The temperature of the component (ambient plus temperature rise) must be within the stated operating temperature range.
2. For flyback topology applications, it is necessary to ensure that the transformer will not saturate in the application. The peak flux density (Bpk) should remain below 2700Gauss. To calculate the peak flux density use the following formula:

$$B_{pk} \text{ (Gauss)} = K1_Factor * I_{pk}(A)$$

3. In high volt- μ sec applications, it is important to calculate the core loss of the transformer. Approximate transformer core loss can be calculated as:

$$CoreLoss \text{ (W)} = 3.97444 \times 10^{-7} \times (\text{Freq_kHz})^{1.62} \times (\text{DB_Gauss})^{2.65}$$

where DB can be calculated as:

For Flyback Topology: $DB = K1_Factor * D(A)$

For Forward Topology: $DB = K1_Factor * \text{Volt-}\mu\text{sec}$

4. The "NL" suffix indicates an RoHS-compliant part number.

Mechanicals

PF0586NL

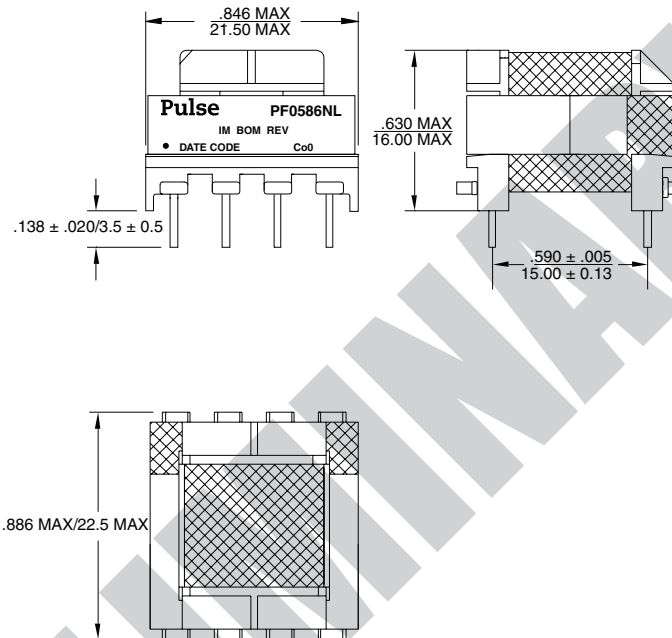

PA2872NL, PA2959NL, PA2979NL

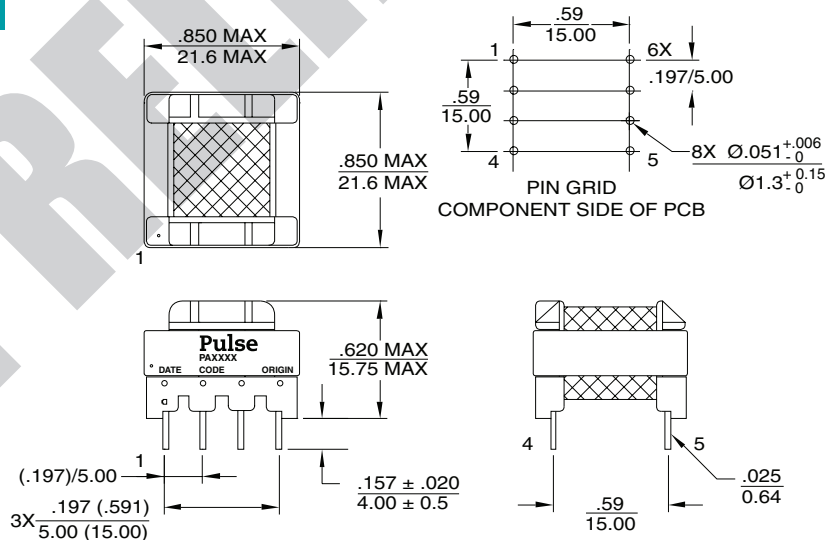

High Frequency Wire Wound Transformers

EF20 Platforms - THT Type

Mechanical (continued)

PA3072NL

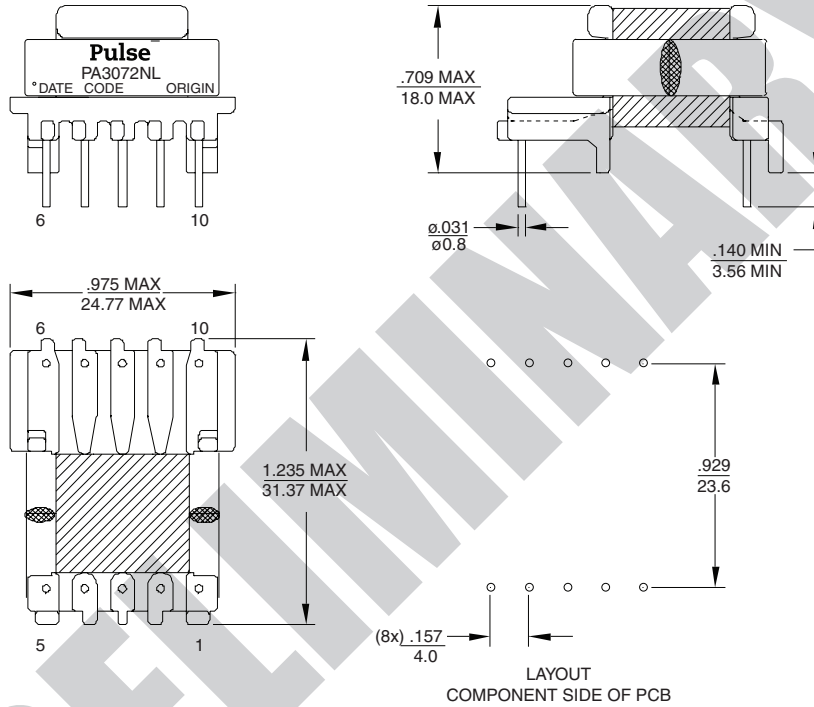

For More Information

Pulse Worldwide Headquarters

12220 World Trade Drive
San Diego, CA
92128
U.S.A.

Tel: 858 674 8100
Fax: 858 674 8262

Pulse Europe

Einsteinstrasse 1
D-71083 Herrenberg
Germany

Tel: 49 7032 78060
Fax: 49 7032 7806 135

Pulse China Headquarters

B402, Shenzhen Academy of
Aerospace Technology Bldg.
10th Kejian Road
High-Tech Zone
Nanshan District
Shenzhen, PR China
518057
Tel: 86 755 33966678
Fax: 86 755 33966700

Pulse North China

Room 2704/2705
Super Ocean Finance
Ctr.
2067 Yan An Road
West
Shanghai 200336
China

Tel: 86 21 62787060
Fax: 86 2162786973

Pulse South Asia

135 Joo Seng Road
#03-02
PM Industrial Bldg.
Singapore 368363

Tel: 65 6287 8998
Fax: 65 6287 8998

Pulse North Asia

3F, No. 198
Zhongyuan Road
Zhongli City
Taoyuan County 320
Taiwan R. O. C.

Tel: 886 3 4356768
Fax: 886 3 4356823 (Pulse)
Fax: 886 3 4356820 (FRE)

Performance warranty of products offered on this data sheet is limited to the parameters specified. Data is subject to change without notice. Other brand and product names mentioned herein may be trademarks or registered trademarks of their respective owners. © Copyright, 2013. Pulse Electronics, Inc. All rights reserved.