

Features

- Cost Effective LED Driver
- Support up to 4 White LEDs
- Output Current up to 40mA per LED
- Low Dropout Voltage
- Ultra Low Quiescent Supply Current: 65µA (typ)
- No Noise and EMI
- Shutdown Current Less than 1µA
- Over Temperature Protection
- Small Packages : SOT23-8 and DFN 2mmx2mm
- Pb-free Package

Applications

- White LED for LCD Display Backlights
- White LED Keypad Backlights
- 1-Cell Li-Ion Battery-operated Equipment Including PDAs, Hand-held PCs, Cellular Phone

Description

The PAM2810 provides 4 regulated current sinks, capable of sinking up to 40mA current to accommodate 4 white LEDs. It requires no charge pump, has no noise and EMI, and significantly improves the efficiency in Li battery range.

LED brightness can be controlled by PWM techniques. The constant current sink is set with an external sense resistor.

Alternatively, a PWM signal applied to the EN pin can vary the anticipated brightness of the LED. The device is in shut down mode when the EN input is logic low.

The PAM2810 is available in SOT23-8 and DFN 2mmX2mm Packages.

Typical Application Circuit

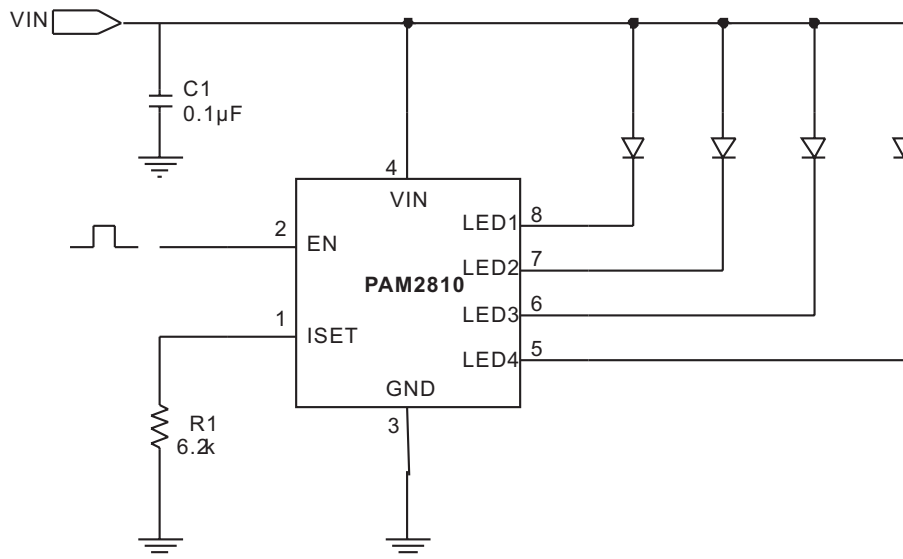
www.DataSheet4U.com

Typical Application Circuit

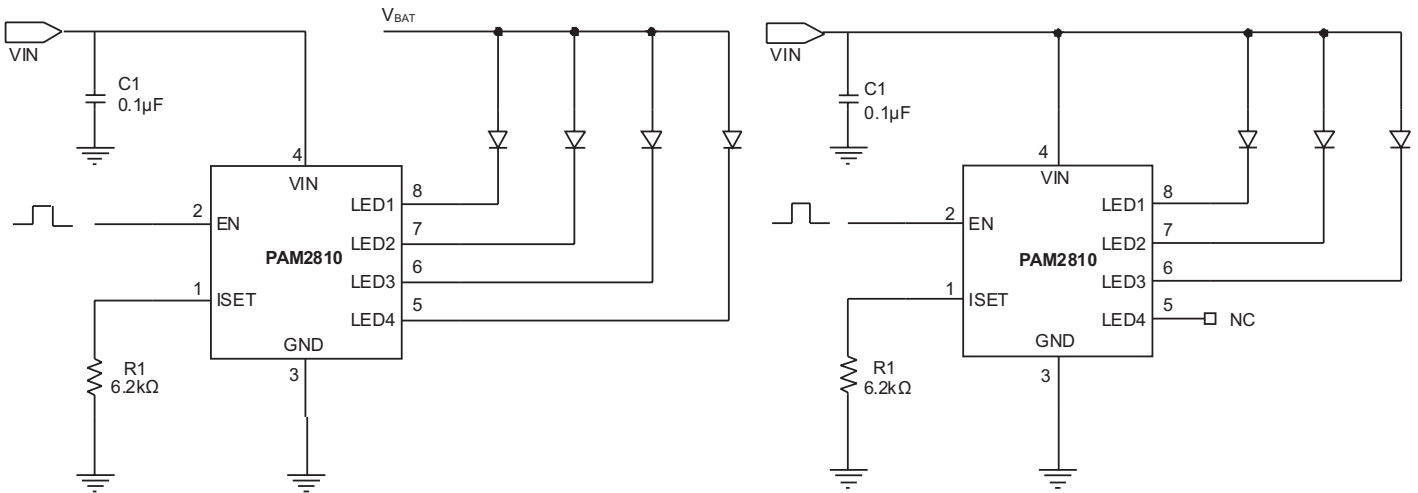

Block Diagram

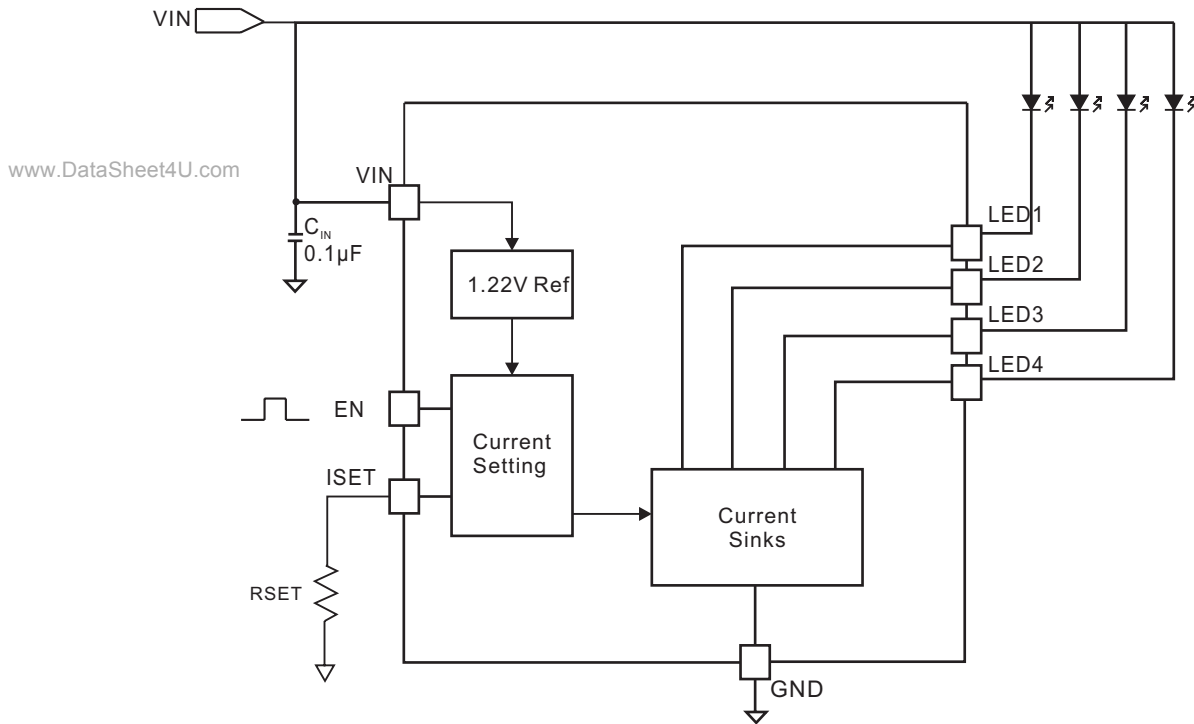

Pin Configuration

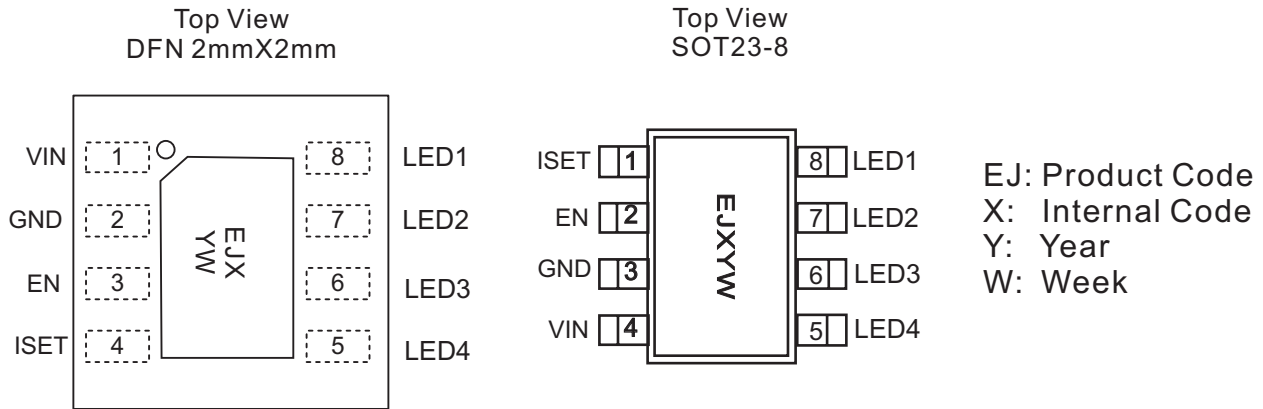

Pin Number		Name	Description
DFN2x2	SOT23-8		
1	4	VIN	Input Voltage
2	3	GND	Ground
3	2	EN	Enable, Allow PWM Brightness Control, Active High
4	1	ISET	LED Current Adjustment Pin
5	5	LED4	LED4 Cathode Terminal
6	6	LED3	LED3 Cathode Terminal
7	7	LED2	LED2 Cathode Terminal
8	8	LED1	LED1 Cathode Terminal



Absolute Maximum Ratings

These are stress ratings only and functional operation is not implied. Exposure to absolute maximum ratings for prolonged time periods may affect device reliability. All voltages are with respect to ground.

Input Voltage Range.....-0.3V to 6V Operation Junction Temperature.....-40°C to 125°C
 PWM Pin voltage.....-0.3V to (VIN+0.3V)/6V Storage Temperature.....-65°C to 150°C
 Maximum Junction Temperature.....150°C Soldering Temperature.....300°C,5sec

Recommended Operating Conditions

Input Voltage Range.....2.7V to 5.5V Operation Temperature Range.....-40°C to 85°C

Thermal Information

Parameter	Symbol	Package	Maximum	Unit
Thermal Resistance (Junction to Ambient)	θ_{JA}	SOT23-8	250	°C/W
		DFN	102	
Thermal Resistance (Junction to Case)	θ_{JC}	SOT23-8	130	
		DFN	20	

Electrical Characteristic

$T_A=25^\circ\text{C}$, $V_{IN}=3.6\text{V}$, $R_{SET}=5.1\text{k}\Omega$, $V_{LEDX}=0.5\text{V}$, unless otherwise noted.

PARAMETER	Symbol	CONDITIONS	MIN	TYP	MAX	UNITS
Input Voltage	V_{IN}		V_f+V_{LED} (Note)	3.6	5.5	V
Output Current	I_{LEDX}	$V_{DD}=5\text{V}$			40	mA
Current Matching Between Any Two Outputs	$I_{LED-MATCH}$				± 5	%
Current Sink Dropout	$V_{DROPOUT}$	$R_{set}=3\text{k}\Omega, I_{LEDX}=40\text{mA}$			0.25	V
ISET PIN Voltage	V_{SET}			1.22		V
Output Current to Current Set Ratio	I_{LEDX}/I_{SET}			100		
Quiescent Supply Current	I_Q	$R_{set}=10\text{M}\Omega$, with no loads		65	80	μA
Shutdown Supply Current	I_{SHDN}	EN=logic low		0.1	1	μA
EN Input Logic High	V_{HI}		1.4			V
EN Input Logic Low	V_{LO}				0.4	V
EN Pin Current	I_{EN}	$V(EN) = 1.5\text{V}$		0.1	1	μA
		$V(EN) = 0\text{V}$		0.1	1	μA

Note: V_f : LED forward voltage; V_{LED} : voltage of LEDx pins.

Typical Performance Characteristics

$T_A=25^\circ\text{C}$, $V_{IN}=3.6\text{V}$, $R_{SET}=5.1\text{k}\Omega$, $V_{LEDX}=0.5\text{V}$, unless otherwise noted.

LED Current VS LED Pin Voltage

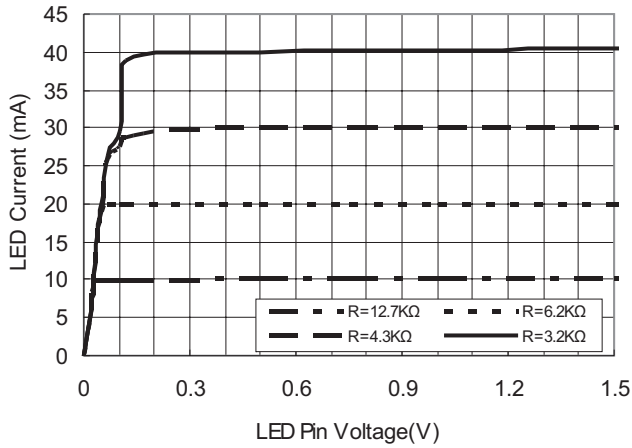

LED Current VS Input Voltage

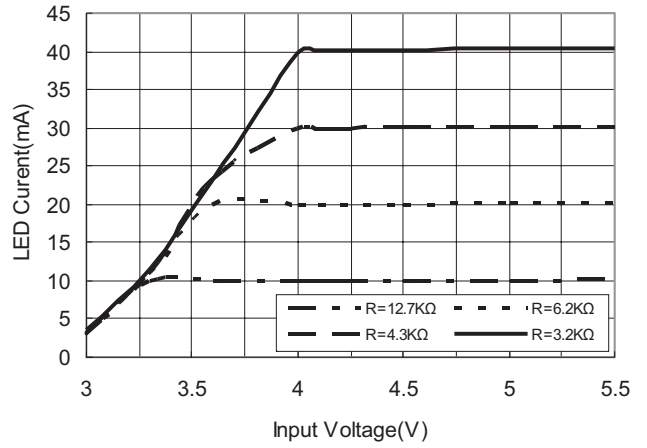

Vset VS Input Voltage

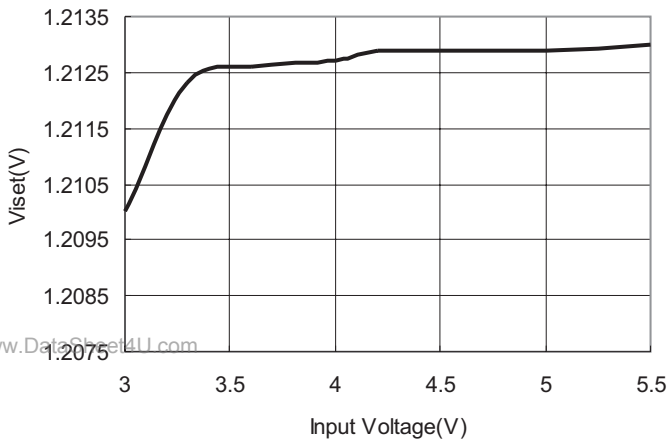

LED Current VS Rset

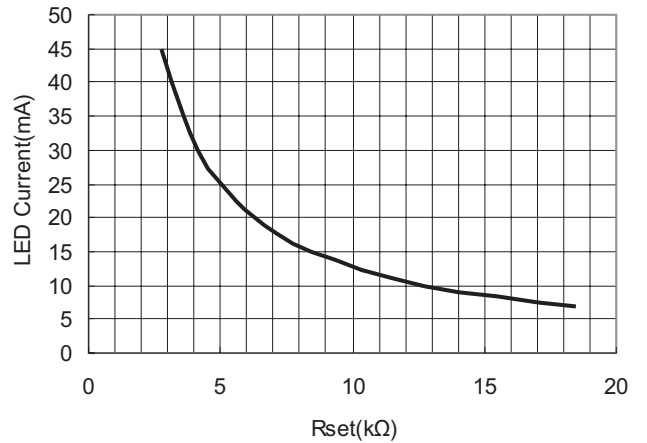

Efficiency VS Input Voltage

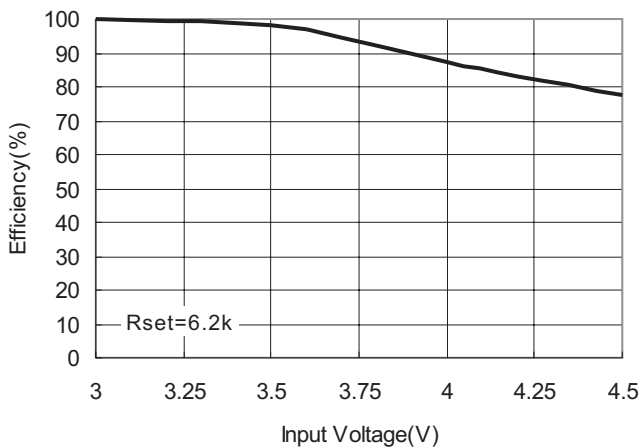

LED Current vs PWM Duty Cycle

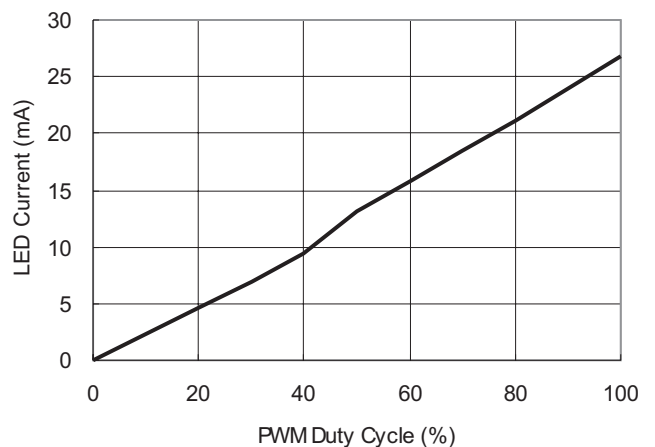

Application Information

The PAM2810 is a 4-channel programmable white-LED driver. The matched current regulators each have a 100:1 ratio between the LEDx outputs and the ISET current. The PAM2810 is capable of supplying 40mA per channel with the proper selection of the external RSET resistor, with a total of 160mA output current available. LED brightness control of PAM2810 can be achieved with a PWM signal.

Output Current Capability

The PAM2810 is capable of providing up to 40mA per LED under an input voltage of 2.7V to 5.5V. An external resistor is used to set the output current, as approximated with the following equation:

$$R_{SET} = 100 * (1.22V / I_{LEDX})$$

In order that the output currents could be regulated properly, the LEDx pin voltage (V_{LEDX}) must be larger than the dropout voltage of the current sink ($V_{DROPOUT}$). To ensure the desired current is obtained, apply the following equation to determine the minimum input voltage:

$$V_{IN} - V_{DIODE} = V_{LEDX} \geq V_{DROPOUT}$$

V_{DIODE} is the diode forward voltage, and some typical value of $V_{DROPOUT}$ can be found from the following table.

www.DataSheet4U.com

Table 1. I_{LED} , R_{SET} and $V_{DROPOUT}$

I_{LED}	R_{SET}	$V_{DROPOUT}$
10mA	12.7k Ω	40mV
20mA	6.2k Ω	80mV
30mA	4.3k Ω	120mV
40mA	3.2k Ω	150mV

PWM Brightness Control

Brightness control can be realized by applying a PWM signal to the EN pin. The constant current is set by the external resistor selected using the RSET equation. The LED brightness is proportional to the duty cycle (D) of the PWM signal. The PWM frequency (f) should be limited to accommodate the start-up time (50 μ s) of the device.

$$D * (1/f) > 50\mu s$$

Table 2. PWM Frequency and Duty cycle

Frequency	Cycle	Duty-Cycle Request
100Hz	10ms	$> \frac{0.5}{100}$
1kHz	1ms	$> \frac{5}{100}$
2 kHz	500 μ s	$> \frac{10}{100}$
4 kHz	250 μ s	$> \frac{20}{100}$
8 kHz	125 μ s	$> \frac{40}{100}$
10 kHz	100 μ s	$> \frac{50}{100}$

The maximum PWM frequency can be selected according to the table above.

If the PWM frequency is much less than 100Hz, flickering may be seen in the LEDs. For the PAM2810, zero duty cycle will turn off the LEDs and a 50% duty cycle will result in an average ILED being half of the programmed LED current. For example, if RSET is set to program 20mA, a 50% duty cycle will result in an average ILED of 10mA. RSET should be chosen not to exceed the maximum current capability of the device.

Shutdown

When the EN pin is logic low, the PAM2810 will be in shutdown mode. While disabled, the PAM2810 typically draws 0.1 μ A current from the power supply. There is no internal pull-up or pull-down on the EN pin.

Over Temperature Protection

The PAM2810 equips over temperature protection. When the junction temperature (T_J) exceeds +150 $^{\circ}$ C, the current source turns off automatically. The device will turn on again after the IC's T_J cools down under +125 $^{\circ}$ C. Operating at absolute maximum temperature is not recommended.

Parallel LEDx Outputs for Increased Current Drive

Output pins LED1 to LED4 may be connected together in any combination to sink higher current through fewer LEDs. For example in Figure 1, outputs LED1 and LED2 are connected together to drive one LED while LED3 and LED4 are connected together to drive a second LED.

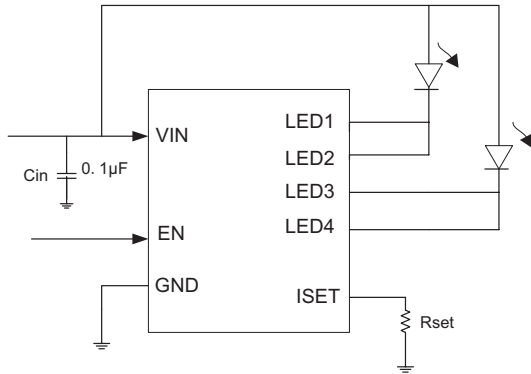

Figure 1. Two Parallel Connected LEDs

With this configuration, two parallel current sinks of equal value both provide current to each LED. If the current sink provides 10mA each, every LED can be driven with 20mA and gets double brightness. Other combinations of parallel outputs can be implemented similarly, such as in Figure 2.

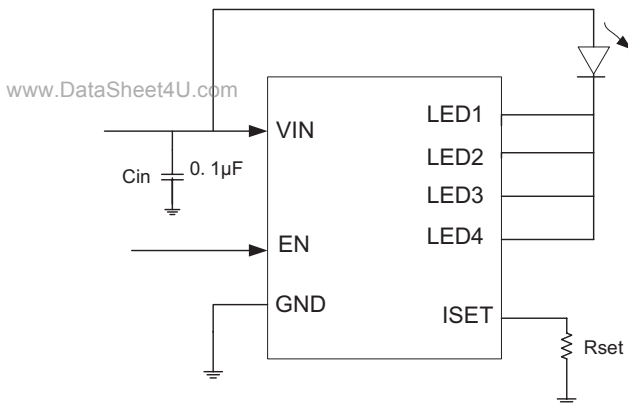

Figure 2. One Parallel Connected LED

Connecting outputs in parallel does not affect internal operation of the PAM2810 and has no impact on the electrical characteristics.

If less than four LEDs connected, the left pin can be floating or connected to GND, as shown in Typical Application Circuit on page 2. Connecting to GND is recommended. The current calculating method is the same as the RSET equation mentioned.

Power Dissipation

The maximum allowable power dissipation that the package is capable of handling can be determined as follows:

$$P_{DMAX} = (T_{JMAX} - T_A) / \theta_{JA}$$

Where T_{JMAX} is the maximum junction temperature, T_A is the ambient temperature, and θ_{JA} is the junction-to-ambient thermal resistance of the specified package. The DFN 2x2 package has a θ_{JA} of 80°C/W and the SOT23-8 250°C/W. This value of θ_{JA} is highly dependant upon the layout of the PCB. The actual power dissipated by the PAM2810 follows the equation:

$$P_{DISS} = (V_{IN} * I_{IN}) - N(V_{DIODE} * I_{LEDX})$$

Where N equals the number of active outputs, V_{DIODE} is the LED forward voltage, and I_{LEDX} is the current supplied to the LEDx.

Input Capacitor Selection

The PAM2810 is designed to work under a stable input voltage. To ensure the stability of input, it may be necessary to add a small input capacitor to help filter out any noise that probably appears on the line. Surface-mount multi-layer ceramic capacitors are recommended, which are small and inexpensive. A capacitance of 0.1µF is typically sufficient.

Ordering Information

PAM2810 X X

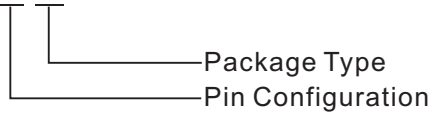

Pin Configuration		Package Type
A: 1: VIN 2: GND 3: EN 4: ISET 5: LED4 6: LED3 7: LED2 8: LED1	B: 1: ISET 2: EN 3: GND 4: VIN 5: LED4 6: LED3 7: LED2 8: LED1	A: SOT23-8 G: DFN 2x2-8

Part Number	Marking	Package	Shipping
PAM2810AG	EJXYW	DFN 2x2-8	3,000 units/Tape & Reel
PAM2810BA	EJXYW	SOT23-8	3,000 units/Tape & Reel

Please consult PAM sales office or authorized distributors for more details.

Outline Dimensions

SOT23-8

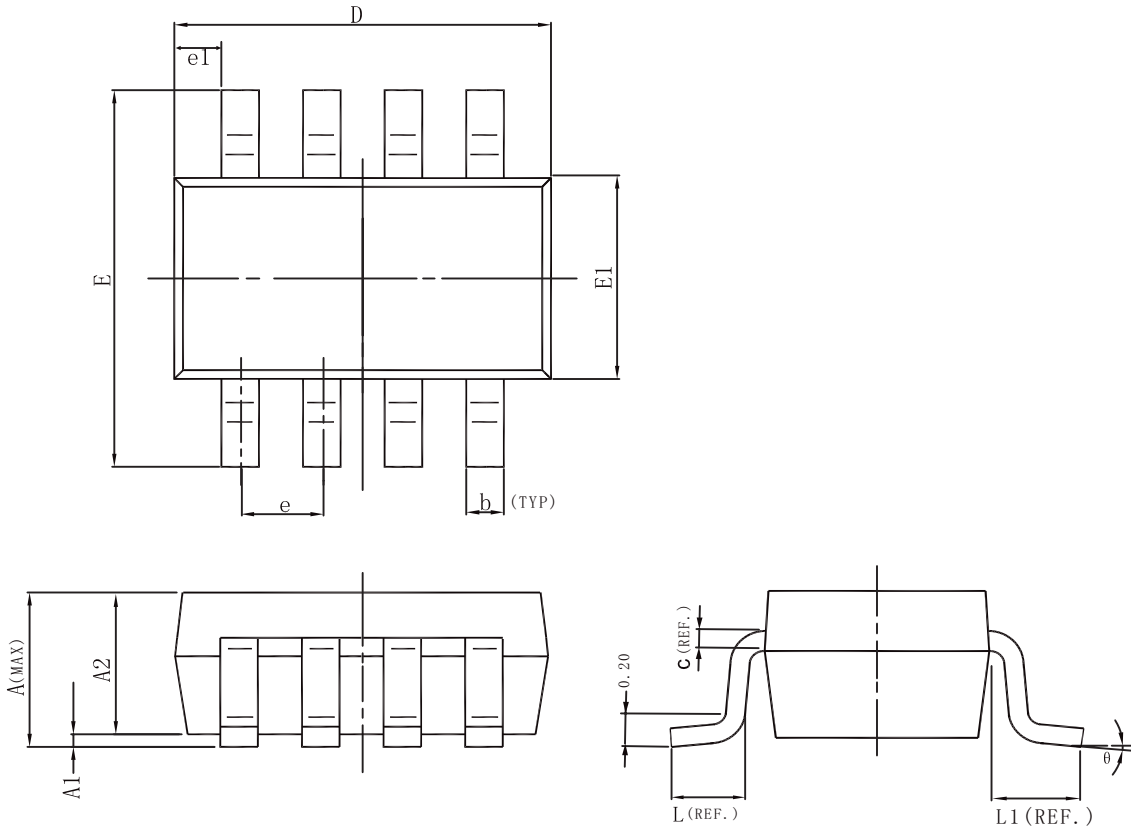
www.DataSheet4U.com

Symbol	Dimensions In Millimeters		Symbol	Dimensions In Millimeters	
	Min	Max		Min	Max
A	1.45 MAX		L	0.30	0.60
A1	0	0.10	L1	0.60 (REF)	
A2	1.10	1.30	theta	0°	10°
c	0.12 (REF)		b	0.22	0.38
D	2.70	3.10	e	0.65 (REF)	
E	2.60	3.00	e1	0.33 (REF)	
E1	1.40	1.80			

Outline Dimensions

DFN 2x2

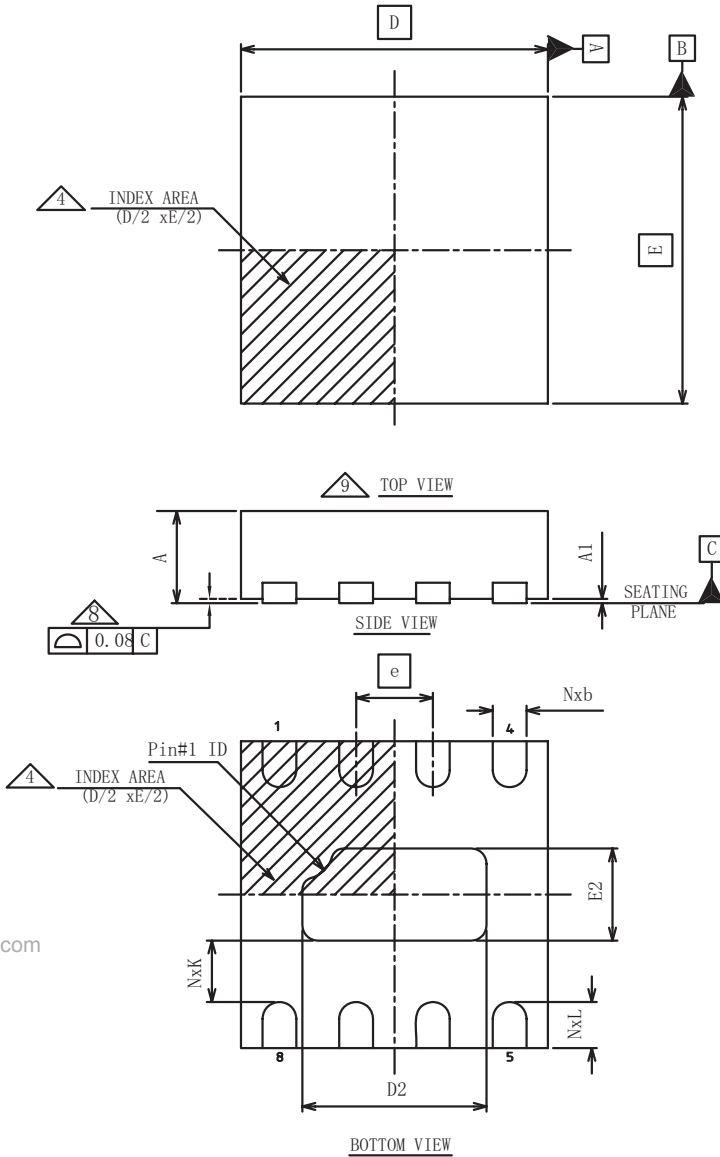

www.DataSheet4U.com

D BSC		2.00
E BSC		2.00
b	MIN	0.18
	NOM	0.25
	MAX	0.30
D2	MIN	1.05
	NOM	1.20
	MAX	1.30
E2	MIN	0.45
	NOM	0.60
	MAX	0.70
L	MIN	0.20
	NOM	0.30
	MAX	0.40
N		8

SYMBOL	COMMON DIMENSION		
	MIN	NOM	MAX
A	0.70	0.75	0.80
A1	0.00	0.02	0.05

Summary Table			
Lead Pitch (e)	Lead Count	Body Size	Pin #1 ID
0.50	8	2X2	R0.20

Unit: Millimeters