

### Features

- Six Constant-Current Output Channels
- Parallel Channels Allow Higher Current per LED String
- Maximum 40V Continuous Voltage Output Limit for Each Channel
- Self-adaptive Vout to Fit Different LED Number
- Adjustable Constant LED Current
- Drives 10 or more LEDs Each String as Long as the String Voltage Less Than 40V
- Internal 2.5A Power MOSFET
- Low 400mV Feedback Voltage at Full Current Improves Efficiency
- Allows Digital PWM and Analog Dimming
- Wide (100:1) PWM Dimming Range without Color Shift
- Independent Dimming and Shutdown Control of the LED Driver
- ±1% Typical Current Matching between Strings
- Open LED Protection: Adjustable Clamp Voltage
- Short LED Protection
- 3 Frequencies Selection: 1.6MHz/1MHz/500kHz
- Wide Input Voltage Range: 4.8V to 28V
- Over Temperature Protection
- Available in 24-pin 4mmx4mm QFN Package
- Pb-free Package

### Applications

- White or RGB Backlighting for LCD TV, LCD Monitor, Notebook, Handy Terminals, and Avionics Displays Panels
- LED Lighting Devices

[www.DataSheet4U.com](http://www.DataSheet4U.com)

### Description

The PAM2846 is a high-efficiency boost type LED driver. It is designed for large LCD panel that employs an array of LEDs as back light source.

The PAM2846 employs a current-mode step-up converter that drives six parallel strings of LEDs connected in multiple series. This built-in string-current-control circuit achieves ±1% typical current matching between strings, which ensures even brightness for all LEDs. The device is able to adapt to different numbers of LEDs in each string or different forward voltage for different types of LEDs and keep the string current constant.

Separate feedback loops limit the output voltage if one or more LEDs open or short. The limit voltage of over voltage protection is adjustable by changing the feedback resistor ratio. The PAM2846 has features cycle-by-cycle current limit to provide consistent operation and soft-start capability. A thermal-shutdown circuit provides another level of protection.

The PAM2846 has a wide +4.8V to +28V input-voltage range and provides adjustable full-scale LED current. The switching frequency of this device can be selected among 500kHz, 1MHz and 1.6MHz according to the application requirements.

### Typical Application

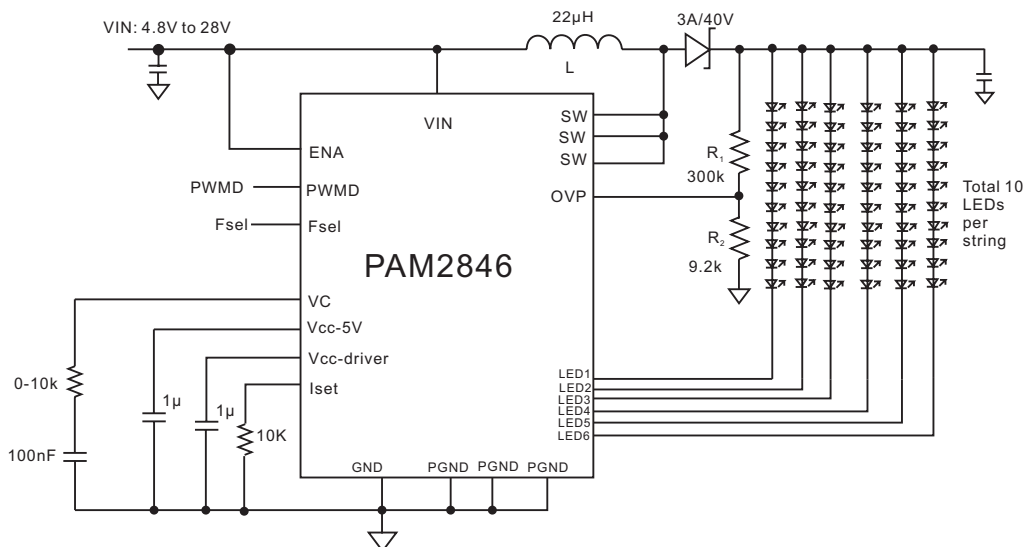

### Block Diagram

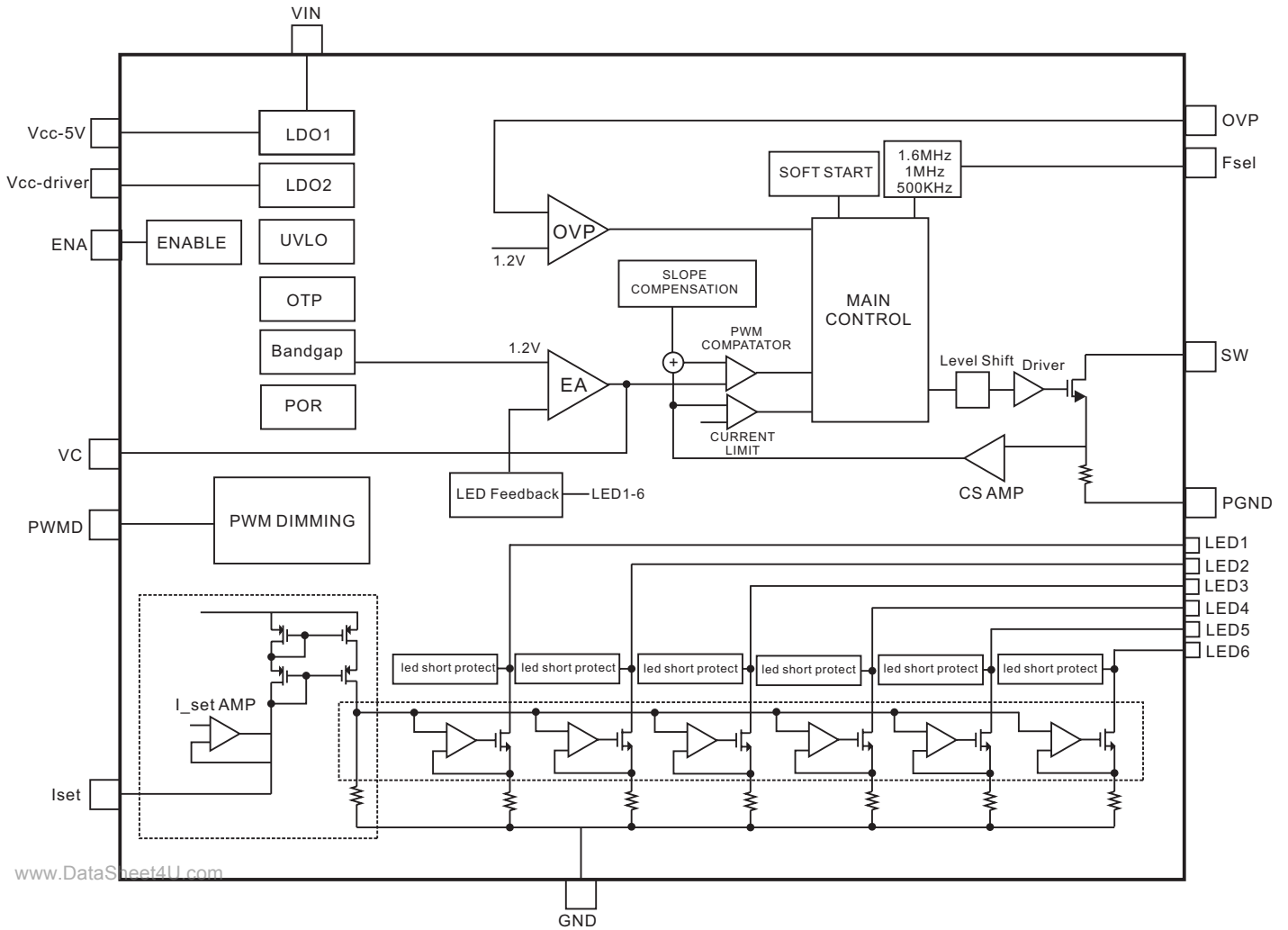

www.DataSheet4U.com

### Pin Configuration

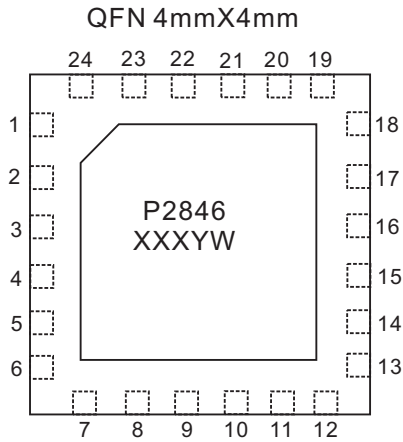

XXX: Internal Code  
 Y: Year  
 W: Weekly

### Pin Descriptions

Pin Number	Name	Description
1	VIN	Supply input
2	Vcc-driver	5V linear regulator output for power MOS driver
3	GND	Ground
4	ENA	Enable input
5	PWMD	PWM dimming control
6	LED1	LED1 cathode terminal
7	LED2	LED2 cathode terminal
8	LED3	LED3 cathode terminal
9	GND	Ground
10	GND	Ground
11	LED4	LED4 cathode terminal
12	LED5	LED5 cathode terminal
13	LED6	LED6 cathode terminal
14	Iset	LED current adjustment pin
15	Vcc-5V	5V linear regulator output
16	VC	Boost stage compensation pin
17	Fsel	Oscillator frequency selection pin
18	OVP	Over voltage protection
19	PGND	Power ground
20	PGND	Power ground
21	PGND	Power ground
22	SW	Power MOS drain
23	SW	Power MOS drain
24	SW	Power MOS drain



### Absolute Maximum Ratings

These are stress ratings only and functional operation is not implied. Exposure to absolute maximum ratings for prolonged time periods may affect device reliability. All voltages are with respect to ground.

VIN,ENA.....	-0.3V To +30V	Junction Temperature Range.....	-40°C to 125°C
SW ,LED.....	-0.3V To +40V	Storage Temperature.....	-40°C to 150°C
Vcc-5V,Vcc-driver,VC.....	-0.3V To +6V	Maximum Junction Temperature.....	150°C
PWMD,Fsel,OVP,Iset.....	-0.3V To +6V	Soldering Temperature.....	300°C,5sec

### Recommended Operating Conditions

Supply Voltage Range.....	4.8V to 28V	Operating Temperature.....	-20°C to 85°C
---------------------------	-------------	----------------------------	---------------

### Thermal Information

Parameter	Package	Symbol	Maximum	Unit
Thermal Resistance (Junction to Case)	4x4mm QFN	$\theta_{JC}$	2	°C/W
Thermal Resistance (Junction to Environment)	4x4mm QFN	$\theta_{JA}$	37	°C/W



**Electrical Characteristic**

T<sub>A</sub>=25°C, V<sub>IN</sub>=ENA=12V, L=22μH, Rset=10kΩ, unless otherwise noted

PARAMETER	Conditions	Min	Typ	Max	Units
Input Voltage Range		4.8		28	V
Quiescent Current	ENA=high (no switching)		1	2	mA
	Fsel=high (1.6M switching frequency)		10		
	Fsel =high (1M switching frequency)		6		
	Fsel =high (500k switching frequency)		3		
	ENA=low		5	20	μA
<b>LDO Stage</b>					
Vcc_5V	No switching	4.7	5	5.5	V
Vcc_5V current_limit	No switching	14	74	90	mA
Vcc_5V UVLO Threshold	No switching	3.9	4.2	4.5	V
Vcc_5V UVLO Hysteresis	No switching		70		mV
Vcc_driver	No switching	4.7	5	5.5	V
Vcc_driver current_limit	No switching	14	74	90	mA
Vcc_driver UVLO Threshold	No switching	3.9	4.2	4.5	V
Vcc_driver UVLO Hysteresis	No switching		70		mV
<b>Boost Stage</b>					
Switch R <sub>dson</sub>	Vcc_5V=5V		0.2		Ω
Switch Current Limit			2.5		A
Switch Leakage Current			1		μA
Switching Frequency	Fsel =Vcc_5V		1.6		MHz
	Fsel =Open		1.0		MHz
	Fsel =Gnd		500		kHz
Minimums Duty Cycle	Fsel =Vcc_5V		20		%
	Fsel =Open		10		%
	Fsel =Gnd		5		%
Maximums Duty Cycle			90		%
VC Source Current			60		μA
VC Sink Current			60		μA



**Electrical Characteristic**

T<sub>A</sub>=25°C, V<sub>IN</sub>=ENA=12V, L=22µH, Rset=10kΩ, unless otherwise noted .

PARAMETER	Conditions	Min	Typ	Max	Units
<b>LED Controller Stage</b>					
Full-Scale LED_Output Current	I= 190*1.2V/Riset, Riset=7.68k		30		mA
	I= 190*1.2V/Riset, Riset=11.3k		20		mA
	I= 190*1.2V/Riset, Riset=22.6k		10		mA
LED current matching		-3	1	+3	%
Iset Voltage			1.2		V
Minimums LED voltage			400		mV
Analog Dimming Range	I= 190*1.2V /Riset	I/32		I	mA
PWM Dimming Frequency		100		1k	Hz
<b>Fault Protection</b>					
LED_ Overvoltage Threshold		4.6	4.9	5.1	V
LED_ Overvoltage Hysteresis			1		V
Overvoltage Threshold			1.2		V
Overvoltage Hysteresis			80		mV
Thermal-Shutdown			150		°C
Thermal-Shutdown Hysteresis			30		°C
<b>Control Interface</b>					
EN High		1.5			V
EN Low				0.4	V
PWMD High		1.5			V
PWMD Low				0.4	V
Fsel High		V <sub>cc_5V-0.5</sub>			V
Fsel Midlevel		1		2	V
Fsel Low				0.5	V
EN Min pulse width	single wire dimming low level	0.5			µs
EN Max pulse width	single wire dimming low level			10	µs
EN off delay	single wire dimming low level		200		µs

### Typical Performance Characteristic

$T_A=25^{\circ}\text{C}$ ,  $V_{IN}=E_{NA}=12\text{V}$ ,  $R_{set}=10\text{k}\Omega$ ,  $L=22\mu\text{H}$ ,  $F_{sw}=500\text{kHz}$ , 10x6 LEDs, unless otherwise noted

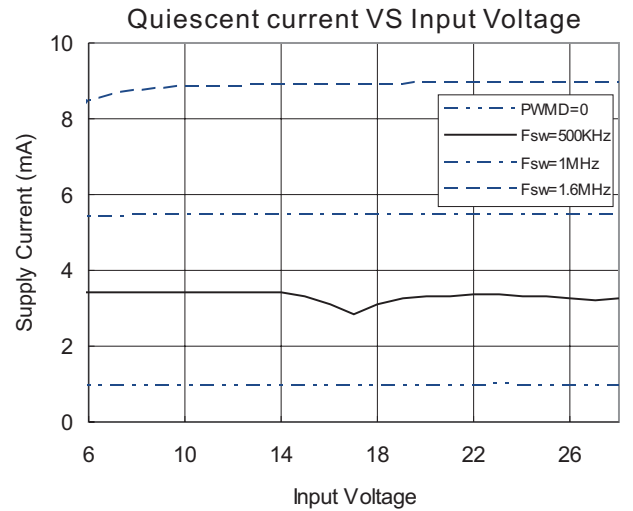
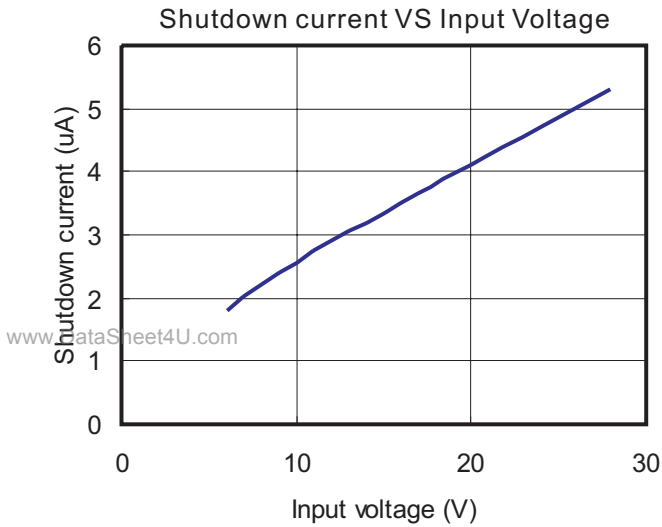
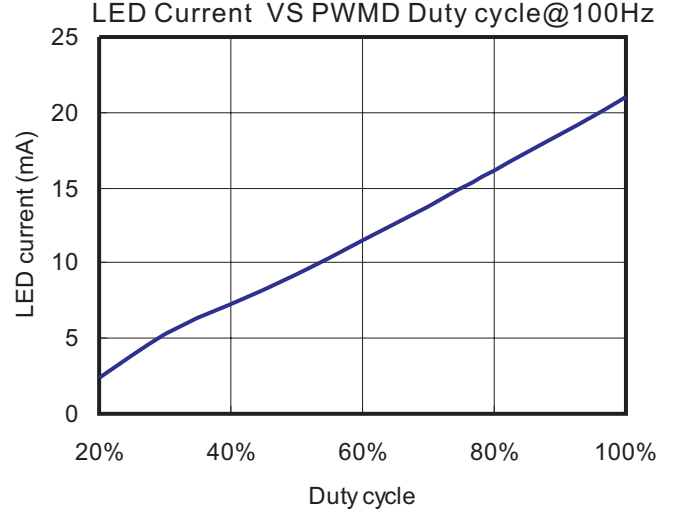
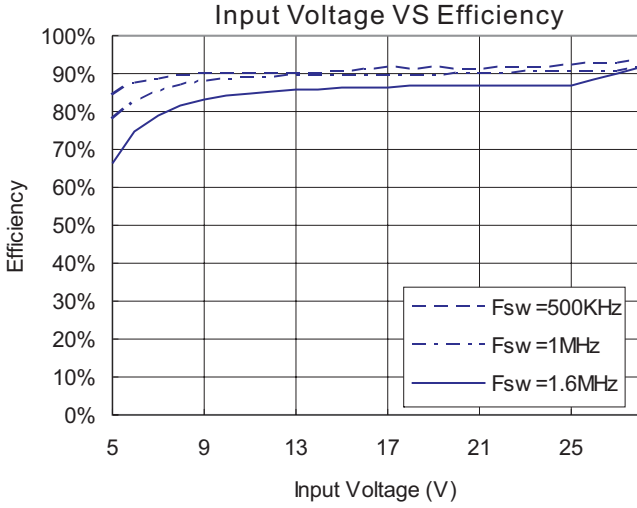

### Typical Performance Characteristic

$T_A=25^\circ\text{C}$ ,  $V_{IN}=ENA=12\text{V}$ ,  $R_{set}=10\text{k}\Omega$ ,  $L=22\mu\text{H}$ ,  $F_{sw}=500\text{kHz}$ , 10x6 LED, unless otherwise noted

Total LED Current Line regulation

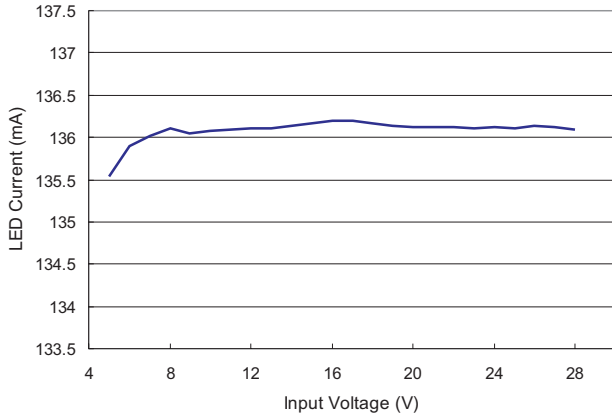

Efficiency VS Input Voltage

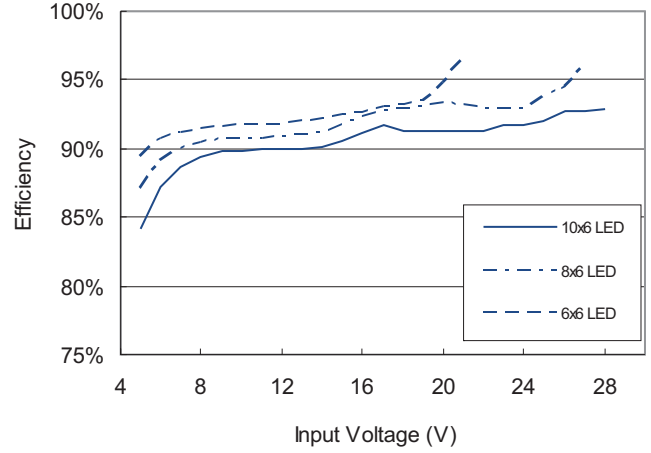

Analog Dimming Signal Step

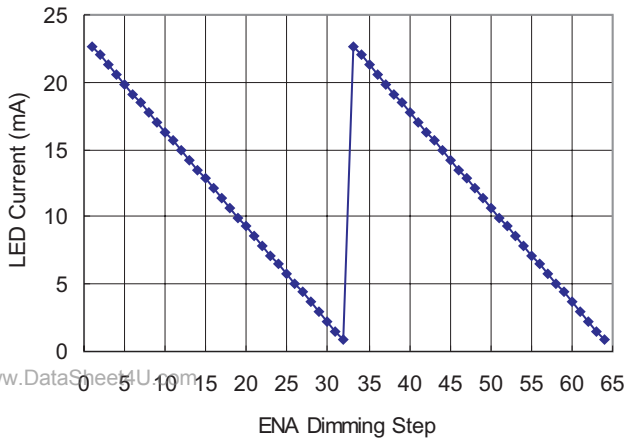

Max Output Current Vs Output Voltage (Per Channel)

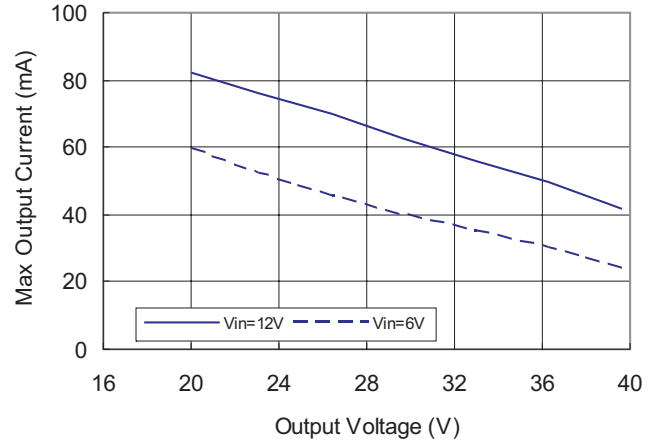



### Typical Performance Characteristic

$T_A=25^{\circ}\text{C}$ ,  $V_{IN}=\text{ENA}=12\text{V}$ ,  $R_{\text{set}}=10\text{k}\Omega$ ,  $L=22\mu\text{H}$ ,  $F_{\text{sw}}=500\text{kHz}$ , 10x6 LEDs, unless otherwise noted.

PWM Dimming (Duty Cycle=20%)

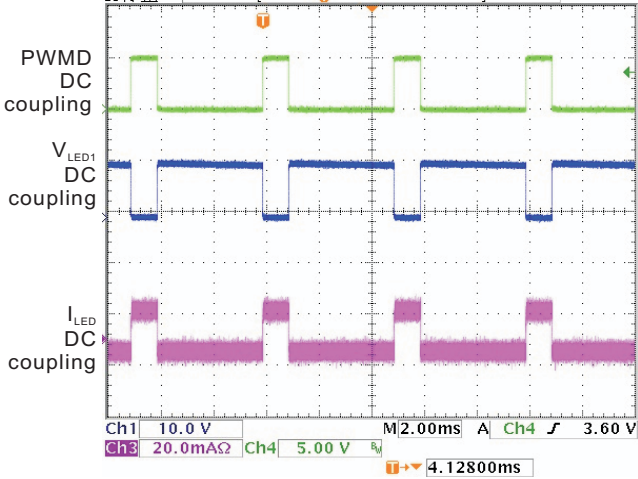

LED Current Waveforms (PWMD=50%)

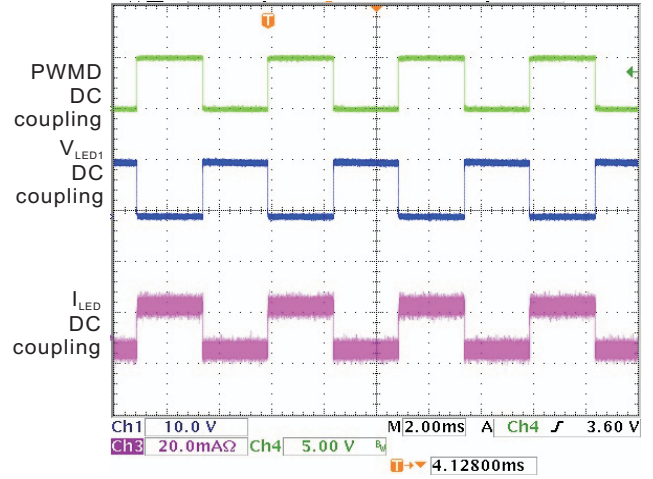

LED Current Waveforms (PWMD=80%)

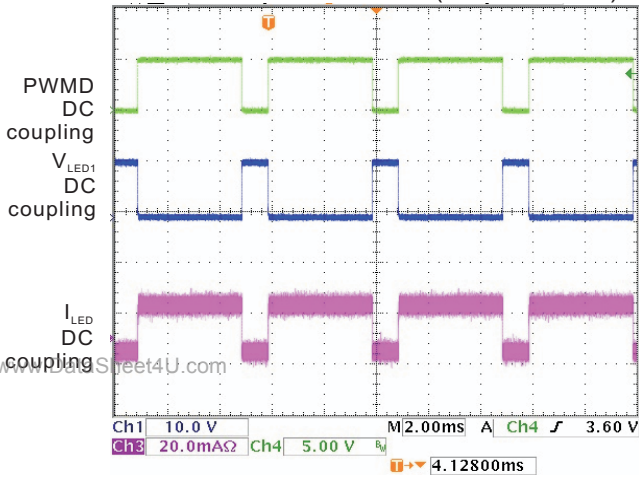

Startup Waveforms

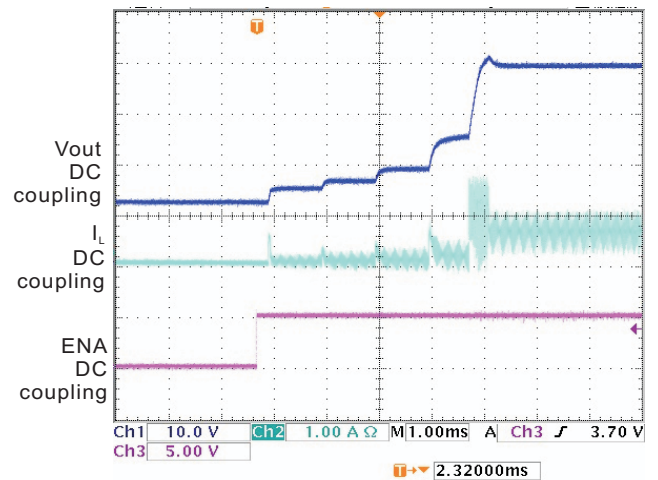

Start up and Shutdown Waveforms

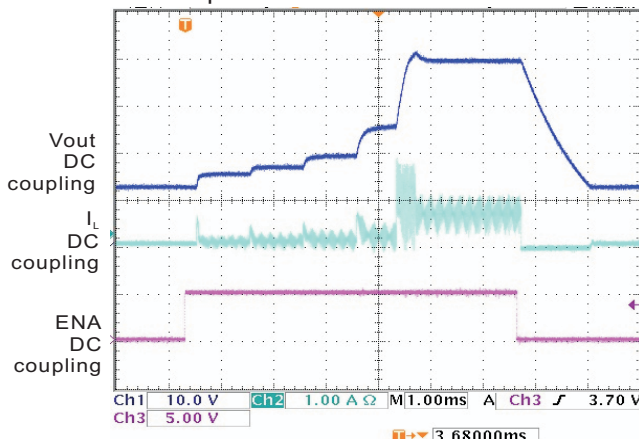

Stable Operation

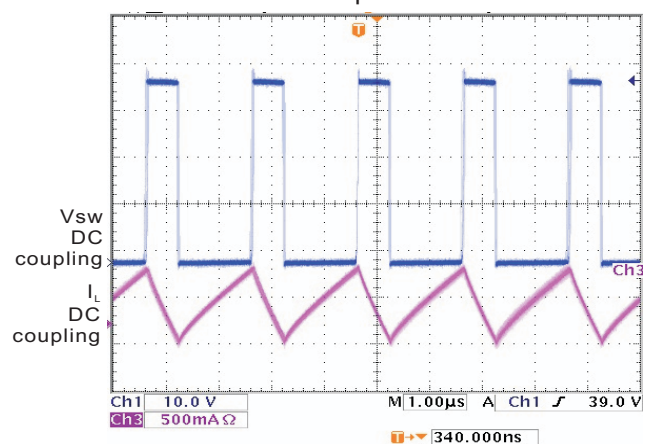

### Application Information

#### Inductor Selection

The inductance, peak current rating, series resistance, and physical size should all be considered when selecting an inductor. These factors affect the converter's operating mode, efficiency, maximum output load capability, transient response time, output voltage ripple, and cost.

The maximum output current, input voltage, output voltage, and switching frequency determine the inductor value. Very high inductance minimizes the current ripple, and therefore reduces the peak current, which decreases core losses in the inductor and  $I^2R$  losses in the entire power path. However, large inductor values also require more energy storage and more turns of wire, which increases physical size and  $I^2R$  copper losses in the inductor. Low inductor values decrease the physical size, but increase the current ripple and peak current. Finding the best inductor involves the compromises among circuit efficiency, inductor size, and cost.

When choosing an inductor, the first step is to determine the operating mode: continuous conduction mode (CCM) or discontinuous conduction mode (DCM). When CCM mode is chosen, the ripple current and the peak current of the inductor can be minimized. If a small-size inductor is required, DCM mode can be chosen. In DCM mode, the inductor value and size can be minimized but the inductor ripple current and peak current are higher than those in CCM.

#### Capacitor Selection

An input capacitor is required to reduce the input ripple and noise for proper operation of the PAM2846. For good input decoupling, low ESR

(equivalent series resistance) capacitors should be used at the input. At least  $2.2\mu\text{F}$  input capacitor is recommended for most applications. A minimum output capacitor value of  $10\mu\text{F}$  is recommended under normal operating conditions, while a  $22\mu\text{F}$  or higher capacitor may be required for higher power LED current. A reasonable value of the output capacitor depends on the LED current. The total output voltage ripple has two components: the capacitive ripple caused by the charging and discharging on the output capacitor, and the ohmic ripple due to the capacitor's equivalent series resistance. The ESR of the output capacitor is the important parameter to determine the output voltage ripple of the converter, so low ESR capacitors should be used at the output to reduce the output voltage ripple. The voltage rating and temperature characteristics of the output capacitor must also be considered. So a value of  $10\mu\text{F}$ , voltage rating (50V) capacitor is chosen.

#### Diode Selection

PAM2846 is high switching frequency convertor, which demands high speed rectifier. It's indispensable to use a Schottky diode rated at 2A, 60V with the PAM2846. Using a Schottky diode with a lower forward voltage drop can improve efficiency of the convertor. The voltage rating of the diode should be greater than the output voltage.

#### Methods for Setting LED Current

There are three methods for setting and adjusting the LED current outlined here. The methods are:

- 1) RSET only
- 2) PWM Input at PWMD
- 3) Single wire logic signal at ENA

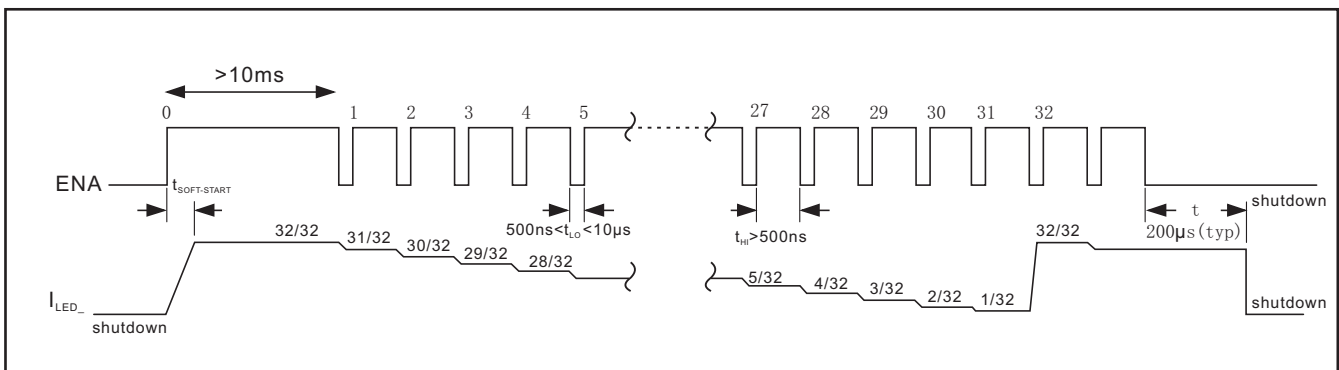

Figure 1. Timing diagram for EN

**Method 1: LED Current Setting with External Resistor  $R_{ISET}$**

The most basic means of setting the LED current is connecting a resistor between  $R_{ISET}$  and GND. The LED current is decided by  $I_{SET}$  Resistor.

$$I_{LED} = 228 / R_{ISET}$$

**Method 2: LED Current Setting Using PWM Signal to PWMD Pin**

This circuit uses resistor  $R_{ISET}$  to set the on state current and the average LED current, then proportional to the percentage of on-time when the PWMD pin is logic low. Average LED current is approximately equal to:

$$I = (t_{on} * I) / (t_{on} + t_{off})$$

Also, the recommended PWM frequency is between 100Hz and 1kHz. Frequency <100Hz can cause the LEDs to blink visibly.

**Method 3: LED Current Setting with single wire logic to ENA Pin**

When the LEDs are enabled by high level, the LED current initially goes to  $I_{LED}$ . Dimming is done by pulsing ENA low (500ns to 10µs pulse width). Each pulse reduces the LED current by 1/32, so after one pulse the LED current is 31/32 \*  $I_{LED}$ . The 32th pulse sets the LED current back to  $I_{LED}$ . Figure 1 shows a timing diagram for EN.

**Setting the Over Voltage Protection**

The OVP pin is connected to the center tap of a resistive voltage divider ( $R_1$  and  $R_2$  in Typical Application diagram) from the high-voltage output.

$$V_{out\_limit} = V_{ov} * (1 + R_2 / R_1)$$

The recommend procedure is to choose  $R_2 = 300k\Omega$  and  $R_1 = 9.2k\Omega$  to set  $V_{out\_limit} = 40V$ . This OVP pin is used for over voltage protect, not for output voltage regulate.

**LED Short Protection**

The PAM2846 uses LED\_OVP function to protect devices when one or more LED(s) is/are shorted.

$$V_{LED} = V_{OUT} - V_f * N$$

Normally  $V_{LED}$  is around 0.4V and  $V_{OUT}$  is decided by LED numbers. When one or more LED(s) is/are shorted, the PAM2846 will clamp  $V_{OUT}$  to make sure all LED pins' voltage is less than 5V. With this function  $V_{OUT}$  will be clamped at  $(5V + V_f * N_{MIN})$ .

Note:

$V_{LED}$ : LED pin voltage

$V_{OUT}$ : Output voltage

$V_f$ : LED forward voltage

$N_{MIN}$ : The minimum LED numbers among all strings.

**LED Open Protection**

The control loop is related to all six LED sinks. When one or more LED(s) is/are opened, the sink will have no current and the device will work in unstable open loop state. The  $V_{OUT}$  voltage will be limited by external resistor divider or  $5V + V_f * N_{MIN}$ , whichever is lower.

### PCB Layout Guidelines

Careful PCB layout is important for proper operation. Use the following guidelines for good PCB layout:

- 1) Minimize the area of the high current switching loop of the rectifier diode and output capacitor to avoid excessive switching noise.
- 2) Connect high-current input and output components with short and wide connections. The high-current input loop goes from the positive terminal of the input capacitor to the inductor, to the SW pin. The high-current output loop is from the positive terminal of the input capacitor through the inductor, rectifier diode, and positive terminal of the output capacitors, reconnecting between the output capacitor and input capacitor ground terminals. Avoid using vias in the high-current paths. If vias are unavoidable, use multiple vias in parallel to reduce resistance and inductance.
- 3) Create a ground island (PGND) consisting of the input and output capacitor ground and PGND pin. Connect all these together with short, wide traces or a small ground plane. Maximizing the width of the power ground traces improves efficiency and reduces output-voltage ripple and

noise spikes. Create an analog ground island (GND) consisting of the output voltage detection-divider ground connection, the  $I_{SET}$  resistor connections, VCC-5V and VCC-driver capacitor connections, and the device's exposed backside pad. Connect the GND and PGND islands by connecting the GND pins directly to the exposed backside pad. Make sure no other connections between these separate ground planes.

- 4) Place the output voltage setting-divider resistors as close to the OVP pin as possible. The divider's center trace should be kept short. Avoid running the sensing traces near SW Pin.

- 5) Place the VIN pin bypass capacitor as close to the device as possible. The ground connection of the VIN bypass capacitor should be connected directly to GND pins with a wide trace.

- 6) Minimize the size of the SW node while keeping it wide and short. Keep the SW node away from the feedback node and ground. If possible, avoid running the SW node from one side of the PCB to the other.

- 7) Refer to the PAM2846 Evaluation board for an example of proper board layout.

PAM2846 Evaluation Board

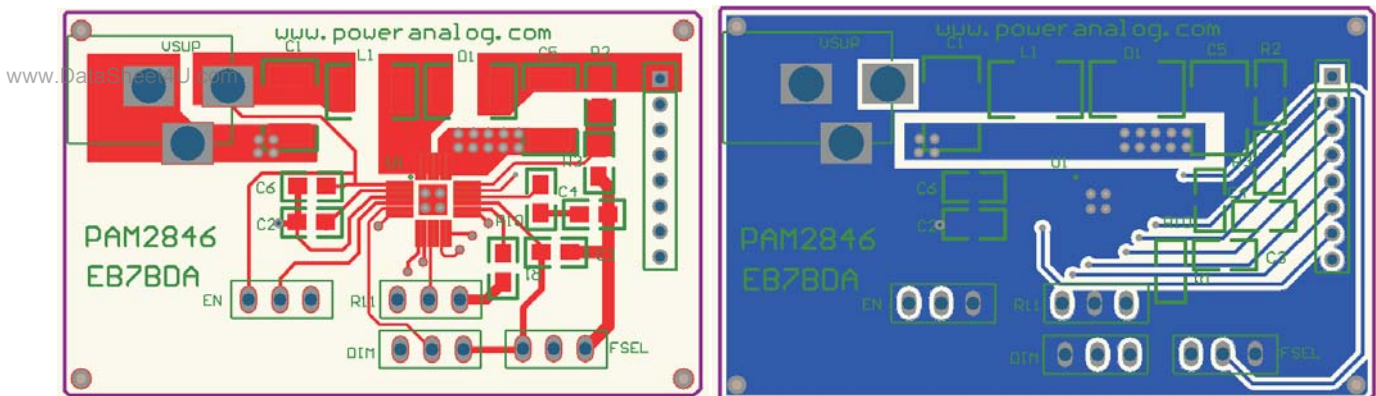

### Ordering Information

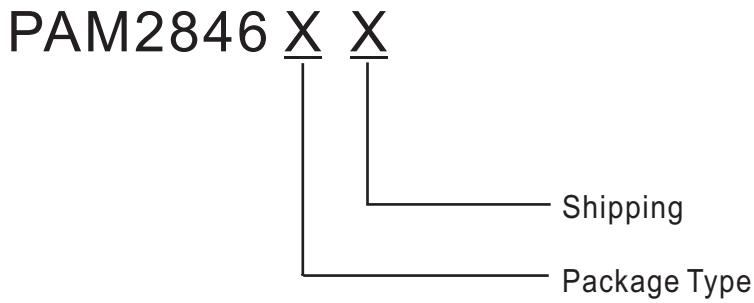

Part Number	Marking	Package Type	Standard Package
PAM2846KR	P2846 XXXYW	QFN 4mmx4mm	3,000 Unites /Tape &Reel



### Outline Dimensions

#### QFN 4mmx4mm

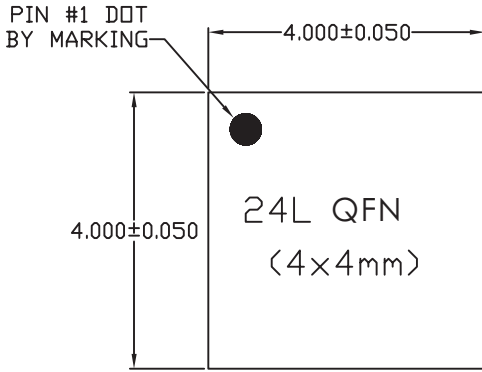

TOP VIEW

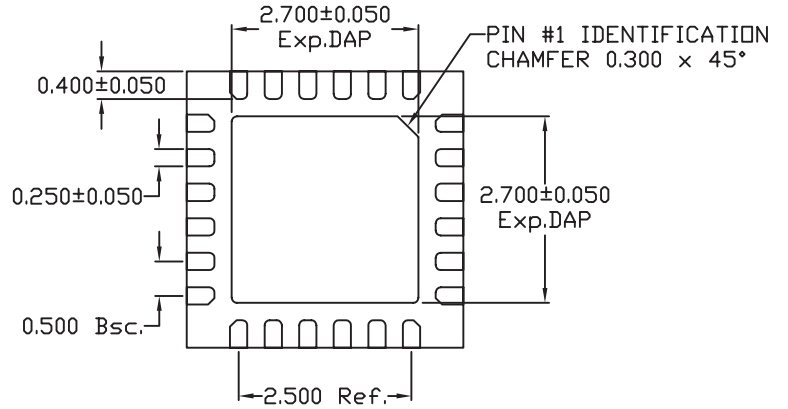

BOTTOM VIEW

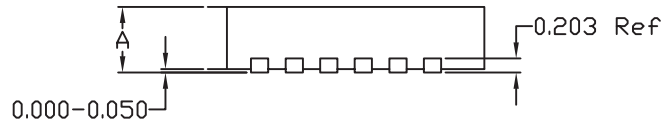

SIDE VIEW

A	MAX.	0.800
	NOM.	0.750
	MIN.	0.700

Note: all dimensions are in millimeters.