

---



---

**PAN3501UI USB OPTICAL MOUSE SENSOR SINGLE CHIP**

---



---

**General Description**

PAN3501UI is a CMOS process optical mouse sensor single chip with USB interface that serves as a non-mechanical motion estimation engine for implementing a computer mouse.

**Features**

- ❑ USB interface
- ❑ Single 5.0 volt power supply
- ❑ Compatible with Microsoft® Windows 2000® and 5-button Wheel Mouse
- ❑ Optical motion estimation technology
- ❑ Complete 2-D motion sensor
- ❑ Accurate motion estimation over a wide range of surfaces
- ❑ High speed motion detection up to 28 inches/sec
- ❑ High resolution up to 800cpi
- ❑ Power saving mode during times of no movement
- ❑ Supports five buttons (R, M, L, B4, B5) and three axes (X, Y, Z) output
- ❑ Z-axis can support two kinds of scroller input (Opto-mechanical and mechanical).
- ❑ Complete Universal Serial Bus® spec V1.1 compatibility
- ❑ Complete USB HID spec V1.1 compatibility
- ❑ Integrated USB transceiver and 1.5Mbps USB serial interface engine

**Key Specification**

<b>Power Supply</b>	<b>Wide operating supply range 4.25V~5.5V</b>
<b>Interface</b>	<b>USB</b>
<b>Optical Lens</b>	<b>1:1</b>
<b>System Clock</b>	<b>18.000 MHz</b>
<b>Speed</b>	<b>28 inches/sec</b>
<b>Acceleration</b>	<b>20g</b>
<b>Resolution</b>	<b>400/600/800 CPI</b>
<b>Frame Rate</b>	<b>3000 frames/sec</b>
<b>Operating Current</b>	<b>12mA @Mouse moving (Normal) 8mA @Mouse not moving (Sleep) 480uA @USB suspend (Suspend)</b>
<b>Package</b>	<b>Shrunk DIP24</b>

**Ordering Information**

Part Number	CPI	Sensor Rotate	Device Type	Z-axis Type
PAN3501UI	400/600/800	0°/+90°/-90°	2D2B/3D3B/3D5B	Mechanical (Z/2)
PAN3501UI-P2	400/600/800	0°/+90°/-90°	2D2B/3D3B/3D5B	Optical (Z/2)
PAN3501UI-P4	400/600/800	0°/+90°/-90°	2D2B/3D3B/3D5B	Optical (Z/4)

## 1. Pin Configuration

### 1.1 Pin Assignment

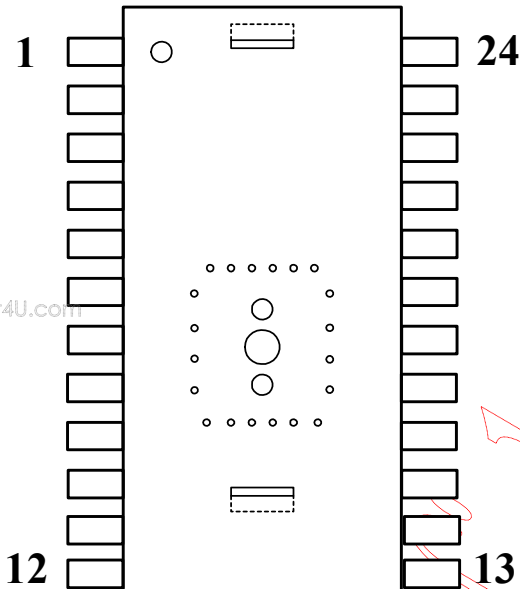

Figure 1. Top View Pinout

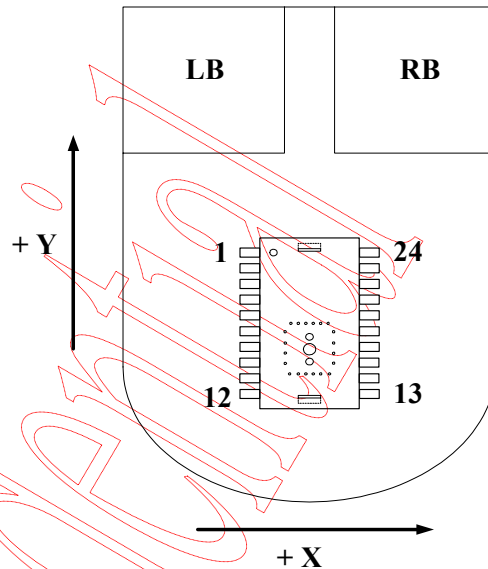

Figure 2. Top View of Mouse

### 1.2 Pin Description

Pin #	Name	Type	Definition
1	Z1	IN	Z axis, support two kinds of scroller input, opto-mechanical and mechanical
2	Z2	IN	Z axis, support two kinds of scroller input, opto-mechanical and mechanical
3	SR	IN	Sensor rotate (0, 1, floating) => (-90°, +90°, 0°), 3-states input
4	IRCTL	OUT	IR LED control
5	BM	IN	Button middle key input, normal pull-high (50k), press connect to low
6	BL	IN	Button left key input, normal pull-high (50k), press connect to low
7	DT	IN	Device type (0, 1, floating) => (3D3B, 2D2B, 3D5B), 3-states input
8	B4	IN	Button 4 key input, normal pull-high (50k), press connect to low
9	B5	IN	Button 5 key input, normal pull-high (50k), press connect to low
10	CPI	IN	CPI select to (0, 1, floating) => (800, 600, 400), 3-states input
11	VSSLED	GND	LED ground
12	LED	I/O	LED control
13	VREFB	BYPASS	Analog voltage reference
14	VREFA	BYPASS	Analog voltage reference
15	VDD5V	PWR	Chip power VDD, 5.0V
16	VSS	GND	Chip ground
17	VDDQ	BYPASS	IO voltage reference
18	OSCIN	IN	Oscillator input, connect to 18.000MHz crystal or resonator
19	OSCOU	OUT	Oscillator output, connect to 18.000MHz crystal or resonator
20	D+	I/O	USB D+
21	D-	I/O	USB D-
22	BR	IN	Button right key input, normal pull-high (50k), press connect to low
23	RFU	IN	Reserve for future use, PAN3501UP used the pin to switch USB or PS/2
24	TEST	IN	Test pin. It is needed to connect to GND in normal operation mode

2. Block Diagram and Operation

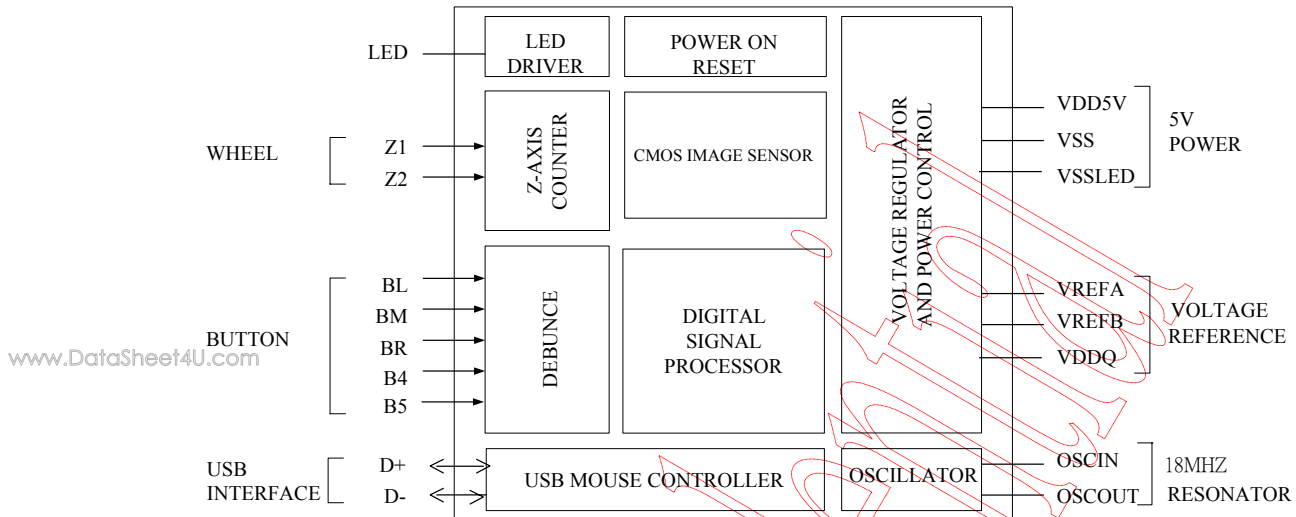

Figure 3. Block diagram

PAN3501UI supports X, Y, Z three axes, and L, R, M, B4, B5 five buttons under USB mode. It is a CMOS process optical mouse sensor single chip with USB interface that serves as a non-mechanical motion estimation engine for implementing a computer mouse.

PAN3501UI is in a 24-pin optical package and comes with the resolution of 400/600/800 counts per inch (cpi) and the rate of motion up to 28 inches per second. It include USB interface so that no mouse controller is needed to interface through USB. PAN3501UI can receive command and echo status or data format, both complete Universal Serial Bus® spec V1.1 and USB HID spec V1.1 compatibility. It is also a cost effective solution to support USB Mouse.

### 3. Specifications

#### Absolute Maximum Ratings

Exposure to absolute maximum rating may affect device reliability.

Symbol	Parameter	Min.	Max.	Unit	Notes
T <sub>STG</sub>	Storage temperature	-40	85	°C	
TA	Operating Temperature	-15	55	°C	
	Lead Solder Temp	-	260	°C	For 10 seconds, 1.6mm below seating plane.
ESD		-	2	kV	All pins, human body model MIL 883 Method 3015
V <sub>DD</sub>	DC supply voltage	-0.5	5.5	V	
V <sub>IN</sub>	DC input voltage	-0.5	5.5	V	All I/O pin

#### Recommend Operating Condition

Symbol	Parameter	Min.	Typ.	Max.	Unit	Notes
T <sub>A</sub>	Operating Temperature	0	-	40	°C	
V <sub>DD</sub>	Power supply voltage	4.25	5.0	5.5	V	
V <sub>N</sub>	Supply noise	-	-	100	mV	Peak to peak within 0-100 MHz
F <sub>CLK</sub>	Clock Frequency	-	18,000	-	MHz	
FR	Frame Rate	-	3000	-	Frames/sec	
Z	Distance from lens reference plane to surface	2.3	2.4	2.5	mm	Refer to Figure 4.
S	Speed	0	14	28	Inches/sec	
A	Acceleration	-	-	20	g	
R	Resolution	-	400	800	cpi	

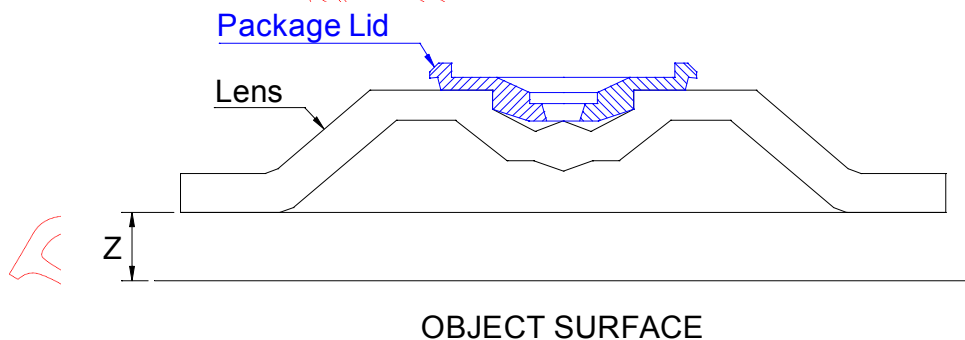

Figure 4. Distance from lens reference plane to surface

www.DataSheet4U.com

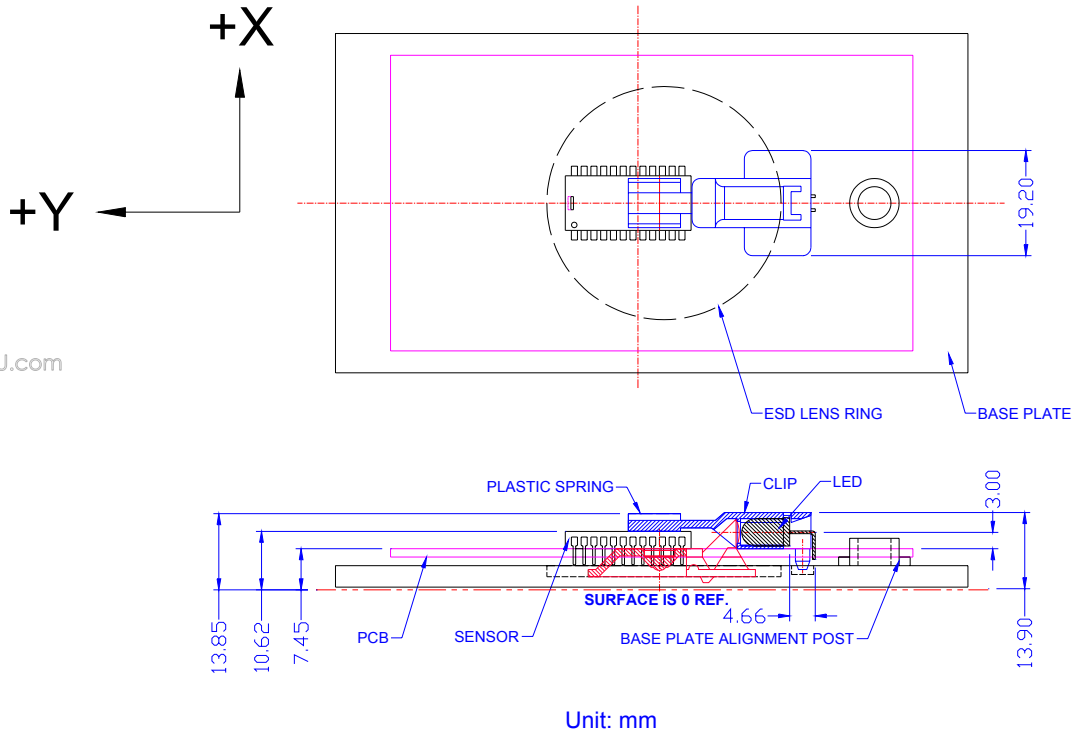

Figure 5. 2D assembly

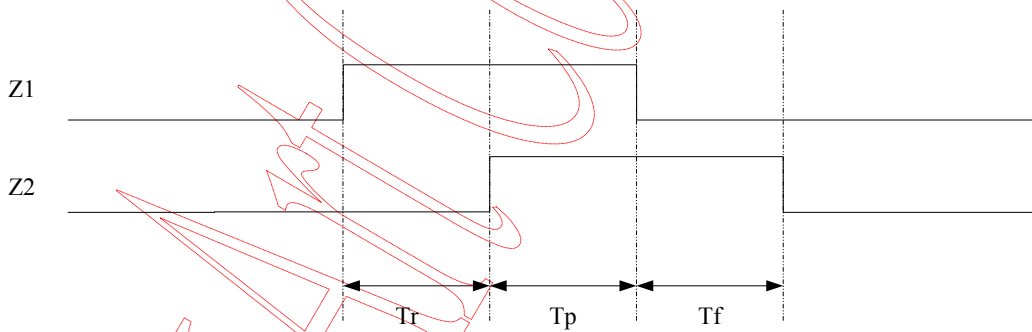

Figure 6. Photo-couples pulse width

**DC Electrical Characteristics**Electrical characteristics over recommended operating conditions. Typical values at 25 °C, V<sub>DD</sub> =5.0 V

Symbol	Parameter	Min.	Typ.	Max.	Unit	Notes
<b>Type: USB Mouse PWR</b>						
I <sub>DD</sub>	Supply Current Mouse moving (normal)	-	12	-	mA	
I <sub>DD</sub>	Supply Current Mouse not moving (sleep1)	-	8	-	mA	
I <sub>DD</sub>	Supply Current Suspend current (suspend)	-	-	480	uA	
<b>Type: BL, BM, BR, B4, B5</b>						
R <sub>PH</sub>	Internal Pull-up Resistance	-	50	-	Kohm	
<b>Type: Z1, Z2</b>						
R <sub>PD</sub>	Internal Pull-down Resistance	-	50	-	Kohm	PAN3501UI built-in internal pull-down resistance. PAN3501UI-PX needs external pull-down resistance.
<b>Type: BL, BM, BR, B4, B5, Z1, Z2</b>						
V <sub>IH</sub>	Input High Voltage	2.0	-	-	V	
V <sub>IL</sub>	Input Low Voltage	-	-	0.8	V	
<b>Type: USB DP, DN</b>						
R <sub>PH</sub>	Internal Pull-up Resistance	-	1.5	-	Kohm	
V <sub>OL</sub>	Output Low Voltage	-	-	0.3	V	
<b>Type: OSCIN</b>						
V <sub>IH</sub>	Input High Voltage	2.0	-	-	V	When driving from an external source
V <sub>IL</sub>	Input Low Voltage	-	-	0.5	V	When driving from an external source
<b>Type: LED</b>						
V <sub>OL</sub>	Output Voltage LOW	-	-	360	mV	I <sub>OL</sub> = 25mA

## 4. USB Interface

### 4.1 USB Command Set Description (USB Descriptor)

The USB HOST detect USB mouse plug-in and assigns a new unique address to the USB mouse, then ask USB mouse device for information about the device description, configuration description, HID report description during enumeration period. After enumeration, the USB device is transfer motion and button value to the USB host.

Descriptor Type	Byte	Byte	Byte	Byte	Byte	Byte	Byte	Byte
Device Descriptor (18 bytes)	12	01	10	01	00	00	00	08
	3A	09	00	25	00	01	01	02
	00	01						
Configuration Descriptor (9 bytes)	09	02	22	00	01	01	04	A0
	32							
Interface Descriptor (9 bytes)	09	04	00	00	01	03	01	02
	00							
Human Interface Device Descriptor (9 bytes)	09	21	10	01	00	01	22	48
	00							
Endpoint Descriptor (7 bytes)	07	05	81	03	04	00	0A	
Human Interface Device Report Descriptor (72 bytes, 3D3B)	05	01	09	02	A1	01	05	09
	19	01	29	03	15	00	25	01
	95	03	75	01	81	02	95	01
	75	05	81	03	05	01	09	01
	A1	00	09	30	09	31	15	81
	25	7F	75	08	95	02	81	06
	C0	09	38	95	01	81	06	09
	3C	15	00	25	01	75	01	95
01	B1	22	95	07	B1	01	C0	

### 4.2 USB Data Report Format

The USB report has two data formats, depending on boot or report protocol is selected. One kind of data format is the boot protocol used in legacy environment as 4.2.1. The other kind of data format is USB report protocol format and sends the additional wheel movement data in the fourth byte as 4.2.2. The wheel is moved forward the fourth byte data is 01H, the wheel is moved backward the fourth byte data is FFH, and the wheel is idle the fourth byte data is 00H.

#### 4.2.1 USB Boot Protocol for Legacy Operation

Byte	Bit	Symbol	Description
1	0	BL	1 = Left button pressed
	1	BR	1 = Right button pressed
	2~7	NC	Reserved
2	0-7	X0~X7	X data (D0 - D7). A positive value indicates motion to the right; a negative value indicates motion to the left. Bit 0=LSB.
3	0-7	Y0~Y7	Y data (D0 - D7). A positive value indicates device motion upward; a negative value indicates motion downward. Bit 0=LSB.

4.2.2 USB Report Protocol

Byte	Bit	Symbol	Description
1	0	BL	1 = Left button pressed
	1	BR	1 = Right button pressed
	2	BM	1 = Middle button pressed
	3	B4	1 = B4 button pressed
	4	B5	1 = B5 button pressed
	5~7	NC	Reserved
2	0-7	X0~X7	X data (D0 - D7). A positive value indicates motion to the right; a negative value indicates motion to the left. Bit 0=LSB.
3	0-7	Y0~Y7	Y data (D0 - D7). A positive value indicates device motion upward; a negative value indicates motion downward. Bit 0=LSB.
4	0-7	Z0~Z7	Z-wheel motion data (D0 - D7). A positive value indicates device motion downward; a negative value indicates motion upward. The Z0-Z7 limit value is $\pm 7$ . Bit 0=LSB.

www.DataSheet4U.com



## 5. Referencing Application Circuit

### 5.1 Typical Application for PAN3501UI with Mechanical Encoder

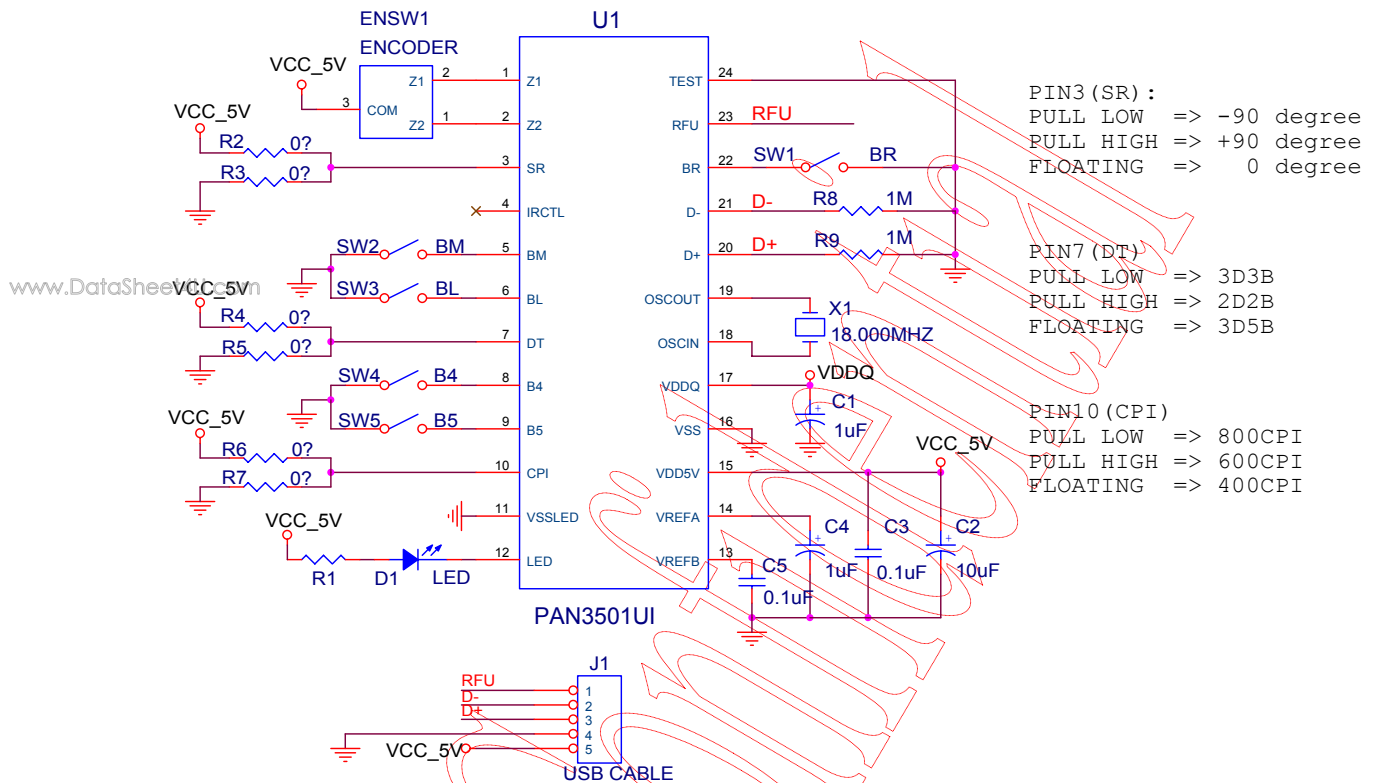

Note:  
Please connect the RFU pin to USB connector shell for future use, PAN3501UP used the pin to switch USB or PS/2.

Figure 7. Application circuit for PAN3501UI (Mechanical Encoder)

5.2 Typical Application for PAN3501UI-PX with Optical Encoder

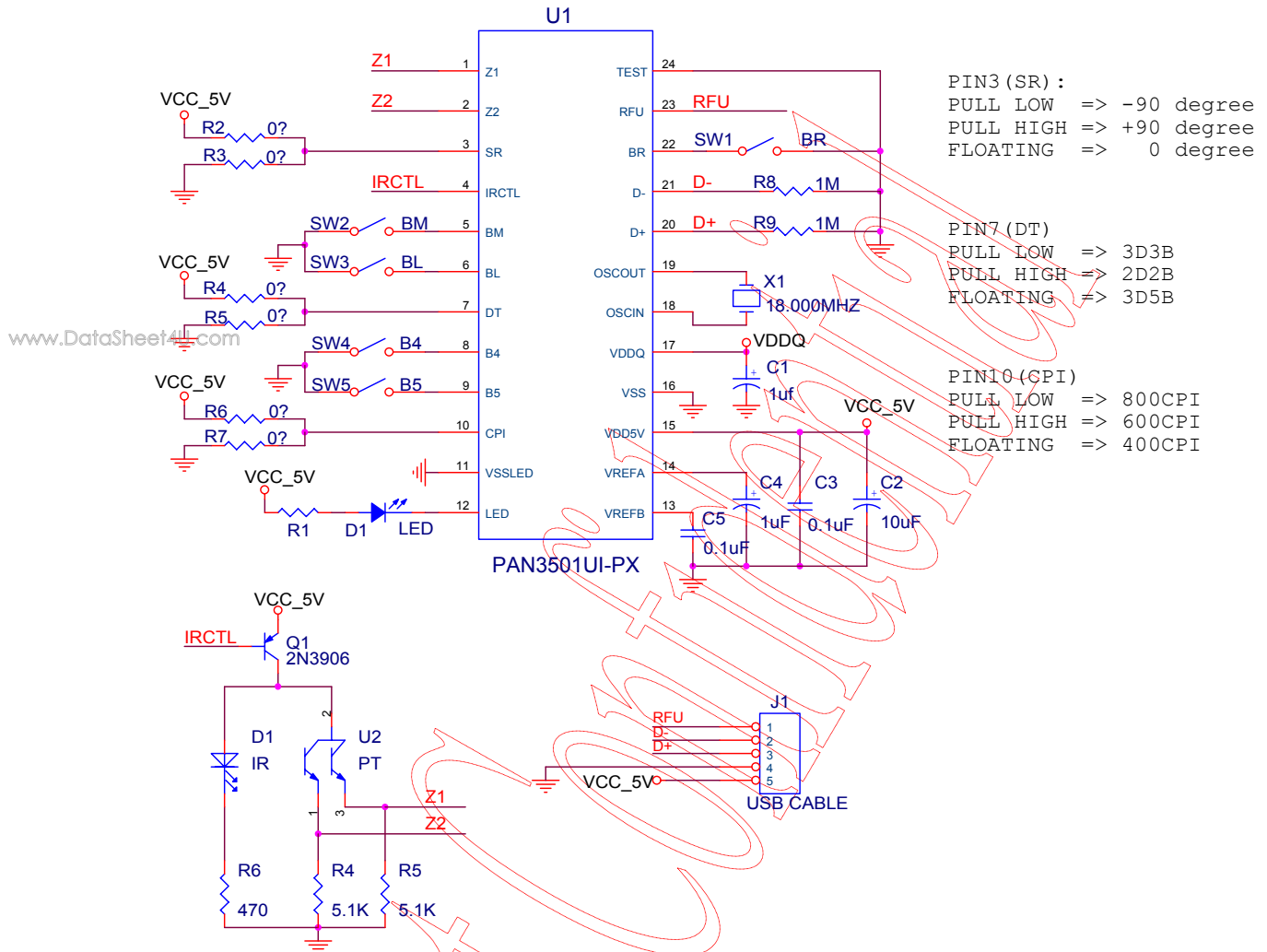

Note:

1. Please connect the RFU pin to USB connector shell for future use, PAN3501UI-PX used the pin to switch USB or PS/2.
2. For resistor value selection, refer to high or low input level of Z1 and Z2 in the D.C. Electrical Characteristics table. The recommended value for R2 is 470ohm. The recommended value for R3/R4 is 5.1Kohm.

Figure 8. Application circuit for PAN3501UI-PX (Optical Encoder)

### 5.3 PCB Layout Consideration

1. Caps for pins 13, 14, 17 **MUST** have trace lengths **LESS** than **5mm**.
2. The trace lengths of OSCOUT, OSCIN must less than **6mm**.

### 5.4 Recommended Value for R1

Radiometric intensity of LED  
Bin limits (mW/Sr at 20mA)

LED Bin Grade	Min.	Typ.	Max.
N	14.7	-	17.7
P	17.7	-	21.2
Q	21.2	-	25.4

Note: Tolerance for each bin will be  $\pm 15\%$

R1 value (ohm), VDD=5.0V

LED Bin Grade	Min.	Typ.	Max.
N	51	100	-
P	51	100	-
Q	51	100	-

## 6. Package Information

### 6.1 Package Outline Drawing

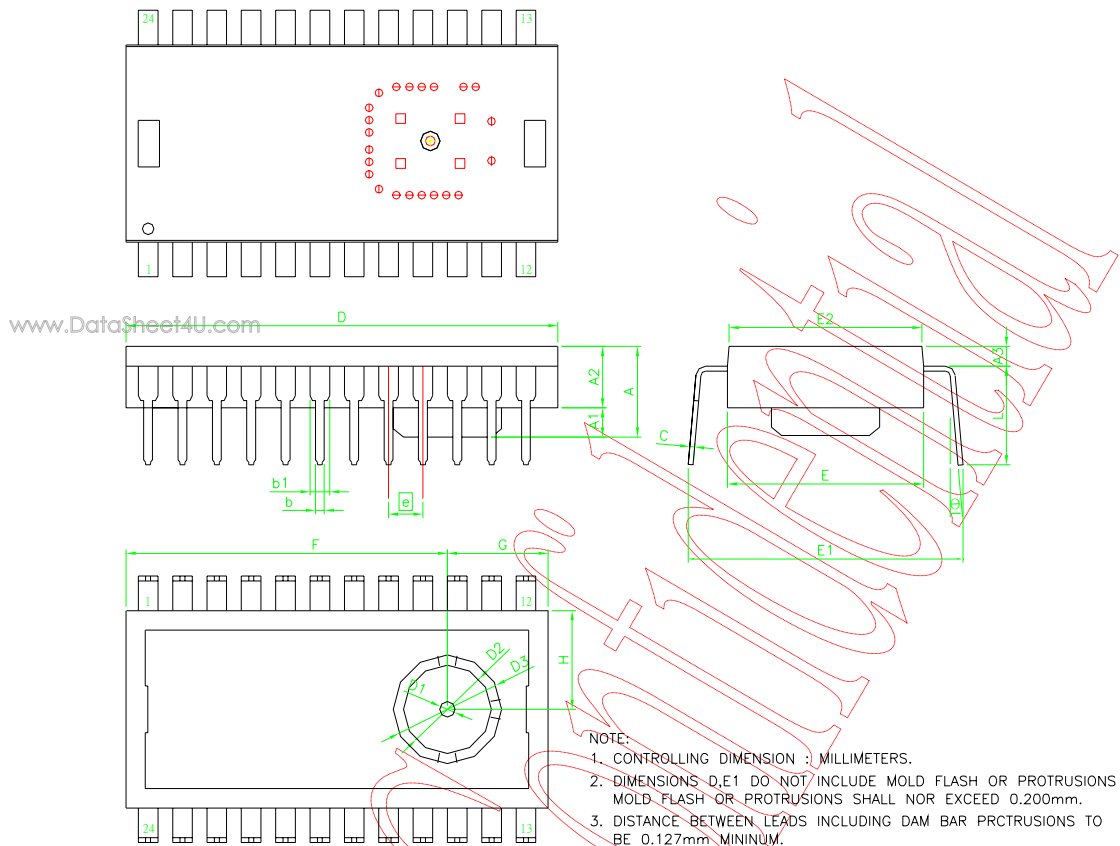

SYMBOL	DIMENSION (MM)			DIMENSION (MIL)		
	MIN.	NOM.	MAX.	MIN.	NOM.	MAX.
A	4.470	4.670	4.870	176	184	192
A1	1.400	1.500	1.600	55	59	63
A2	3.070	3.170	3.270	121	125	129
A3	0.920	1.020	1.120	36	41	44
b	0.357	0.457	0.508	14	18	20
b1	0.889	1.016	1.143	35	40	45
c	0.203	0.254	0.279	8	10	11
D	21.74	21.84	21.94	856	860	864
D1	0.700	0.800	0.900	28	32	36
D2	4.450	4.550	4.650	175	179	183
D3	5.500	5.600	5.700	217	221	224
E	10.060	10.160	10.260	36	40	44
E1	14.120	14.220	14.320	556	560	564
E2	9.880	9.980	10.080	389	393	397
F	16.537	16.637	16.737	651	655	659
G	5.107	5.207	5.307	201	205	209
H	4.980	5.080	5.180	196	200	204
e	1.778 BASIC			70 BASIC		
L	4.980	5.080	5.180	196	200	204
ø	5°	—	12°	5°	—	12°

Figure 9. Package outline drawing

6.2 Recommended PCB Mechanical Cutouts and Spacing

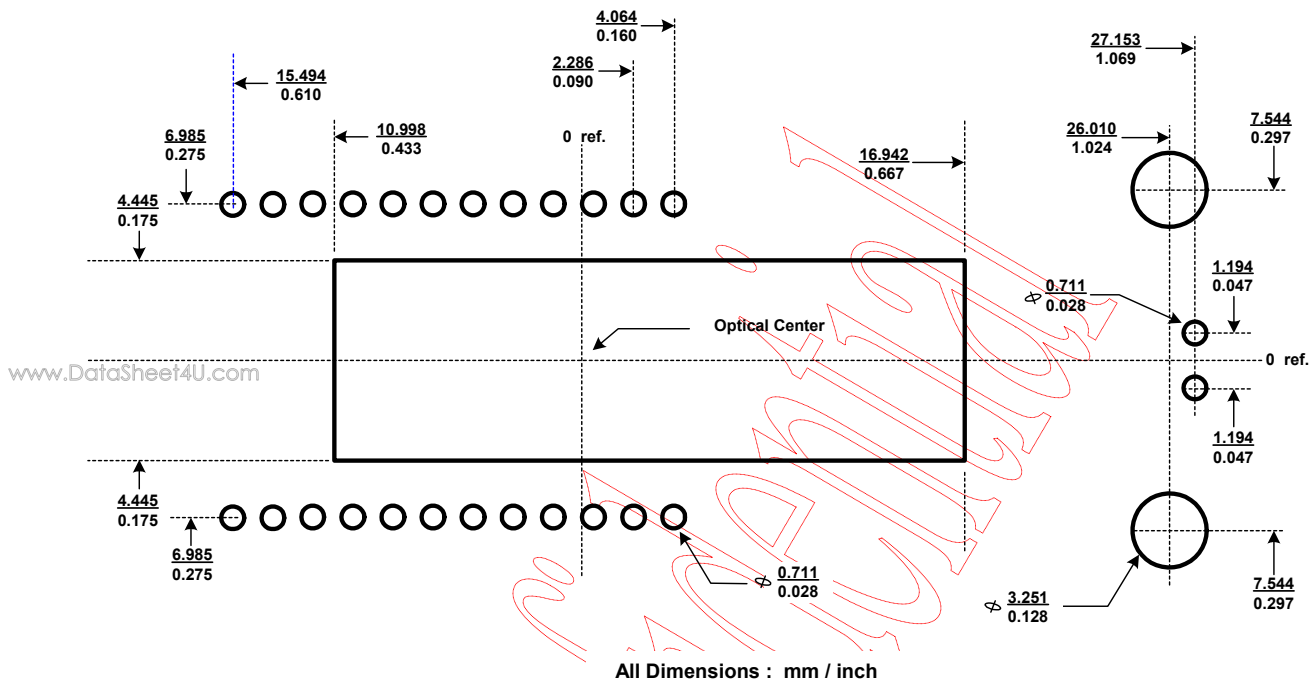

Figure 10. Recommended PCB mechanical cutouts and spacing

## 7. NSTL Compatibility Test

PAN3501UI has passed the NSTL Compatibility Test Program, which conducts an objective quality assurance test suite to verify correct operation, functionality, and compatibility of system products. "The NSTL standard testing methodologies assessed the compatibility of PAN3501UI at the NSTL/ALLION Labs testing facility. And, it shows that it is getting along great and operated correctly with various software applications and add-on devices under a variety of Operating Systems." cited from the NTSL Test Report. Accordingly, PAN3501UI fully meets NTSL Compatibility Test Standard and is able to carry the NTSL Seal.

## 8. Update History

Version	Update	Date
V1.0	Creation, Preliminary 1 <sup>st</sup> version	04/06/2005

www.DataSheet4U.com