

PAW3509DH-TXWA USB OPTICAL MOUSE SINGLE CHIP
General Description

The PAW3509DH-TXWA is a CMOS process optical mouse sensor single chip with USB interface that serves as a non-mechanical motion estimation engine for implementing a computer mouse.

Features

- USB interface
- Single power supply
- Optical motion estimation technology
- Complete 2-D motion sensor
- Accurate motion estimation over a wide range of surfaces
- High speed motion detection up to 37 inches/sec
- High resolution up to 2000 CPI
- Power saving mode during times of no movement
- Support up to FIVE buttons (R, M, L, 4, 5) and three axes (X, Y, Z) output
- Z-axis can support two kinds of scroller input (Mechanical or IRPTR)
- Support Tilt wheel: FOUR ways navigation with the scroll wheel up, down, left and right
- USB spec.
 - Complete Universal Serial Bus specification V1.1 compatibility
 - Complete USB HID specs V1.11 compatibility
 - Compliant to the USB specification version 2.00
 - Integrated USB transceiver and 1.5Mbps USB serial interface engine
 - 16-bit X/Y report format
- One dedicated pin for CPI switch and indication
- Flexibility for device type configuration.
 - Interface: USB / PS2
 - USB type: 4D5B, 3D3B
 - CPI resolution: 400 ~ 2000
 - CPI switch type: 4 types available
 - Sensor rotation: 0, +90(clockwise), -90, 180

Key Specification

Power Supply	Wide operating supply range 4.25V ~ 5.5V
Interface	USB
Optical Lens	1:1
System Clock	24.000 MHz
Speed	37 inches/sec
Acceleration	15g
Resolution	1000(Default)/1600/600 CPI
CPI Switch Level	1000 -> 1600 -> 600 -> 1000 ... (Default)
Frame Rate	4000 frames/sec
Operating Current	10mA @Mouse moving (Normal) 5mA @Mouse not moving (Sleep) 480uA @USB suspend (Suspend)
Package	Shrunk DIP20

Ordering Information

Part Number	Device Type	Interface	Roller
PAW3509DH-TXWA	4D5B	USB (LS,16-bitXY)	Mechanical/IRPTR

1. Pin Configuration

1.1 Pin Description

Pin #	Name	Type	Definition
1	Tilt-R	I	Tilt wheel button right key input.
2	OSCOUT	O	Oscillator output.
3	OSCIN	I	Oscillator input.
4	CPI	I/O	CPI switch input and indication (PWM) output.
5	BL	I	Button left key input.
6	IRCTL	I/O	Mechanical(L)/IRPTR(H) trapping input and IRPTR power control output.
7	VDD5V	PWR	Chip power VDD 5.0V.
8	VSS	GND	Chip ground.
9	VDDQ	PWR	I/O voltage reference output.
10	VDDA	PWR	Analog voltage reference output.
11	D+	I/O	USB D+.
12	D-	I/O	USB D-.
13	BR	I	Button right key input.
14	BM	I	Button middle key input.
15	LED	O	LED control.
16	Z2	I	Z-axis mechanical / IRPTR scroller input.
17	Z1	I	Z-axis mechanical / IRPTR scroller input.
18	Tilt-L	I	Tilt wheel button left key input.
19	B5	I	Button 5th key input.
20	B4	I	Button 4th key input.

1.2 Pin Assignment for Sensor Rotate 0°

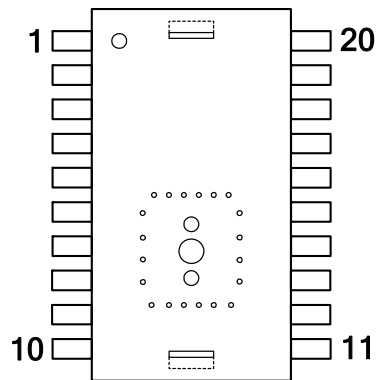

Figure 1. Top View Pinout

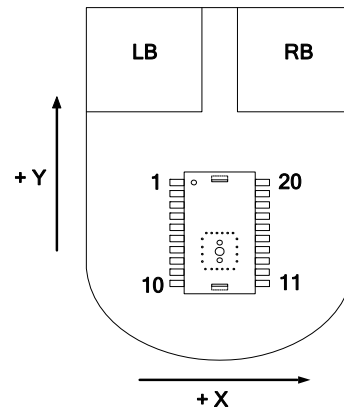

Figure 2. Top View of Mouse

2. Block Diagram and Operation

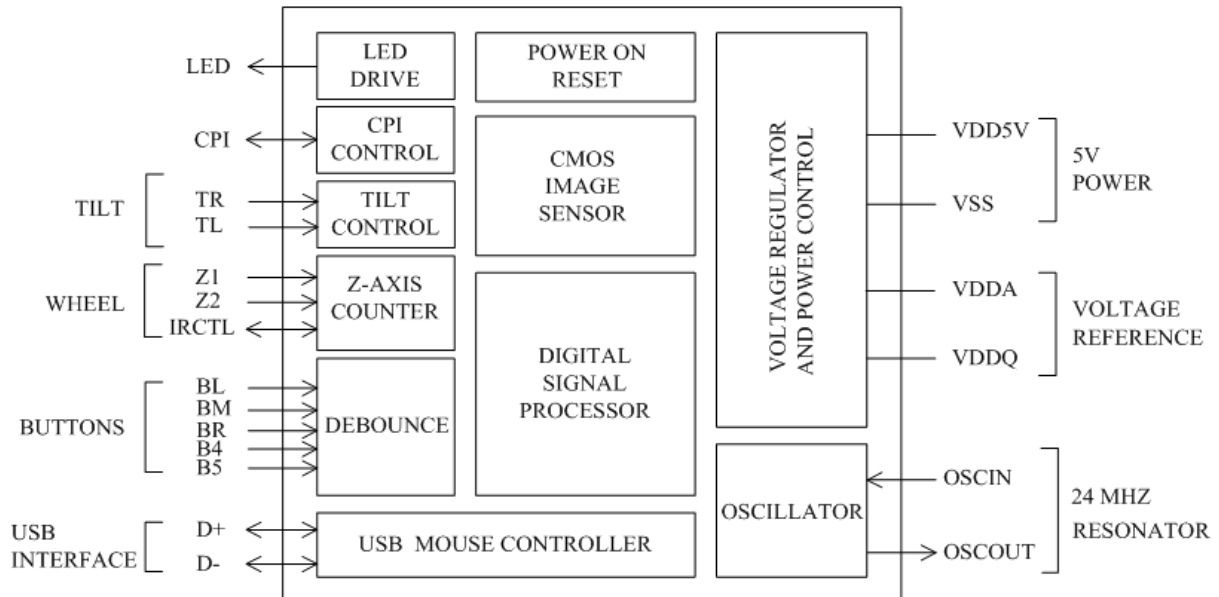

Figure 3. Block Diagram

The PAW3509DH-TXWA supports X, Y, Z three axes, and L, R, M, 4, 5 five buttons under USB mode. It is a CMOS process optical mouse sensor single chip with USB interface that serves as a non-mechanical motion estimation engine for implementing a computer mouse.

The PAW3509DH-TXWA is in a 20-pin optical package and comes with the resolution of 1000/1600/600 counts per inch (CPI) and the rate of motion up to 37 inches per second. It includes USB interface so that no mouse controller is needed to interface through USB. The PAW3509DH-TXWA can receive command and echo status or data format, both complete Universal Serial Bus[®] spec V1.1 and USB HID spec V1.11 compatibility. It is also a cost effective solution to support USB Mouse.

3. Referencing Application Circuit

3.1 3D3B/4D5B Application Circuit

Mouse SoC (3D3B, Mechanical)

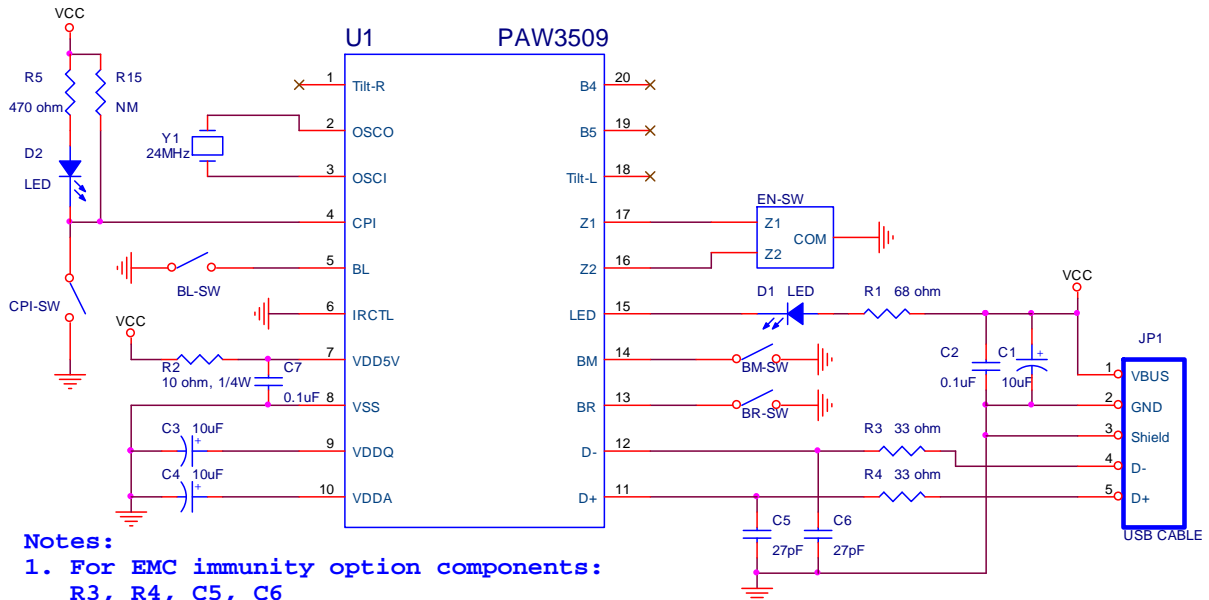

- Notes:**
1. For EMC immunity option components:
R3, R4, C5, C6
 2. Connector JP1 is suggested to has the pin sequence like:
VBUS, GND, Shield, D-, D+

Figure 4. 3D3B Application Circuit with Mechanical Zwheel.

Mouse SoC (3D3B, IRPTR)

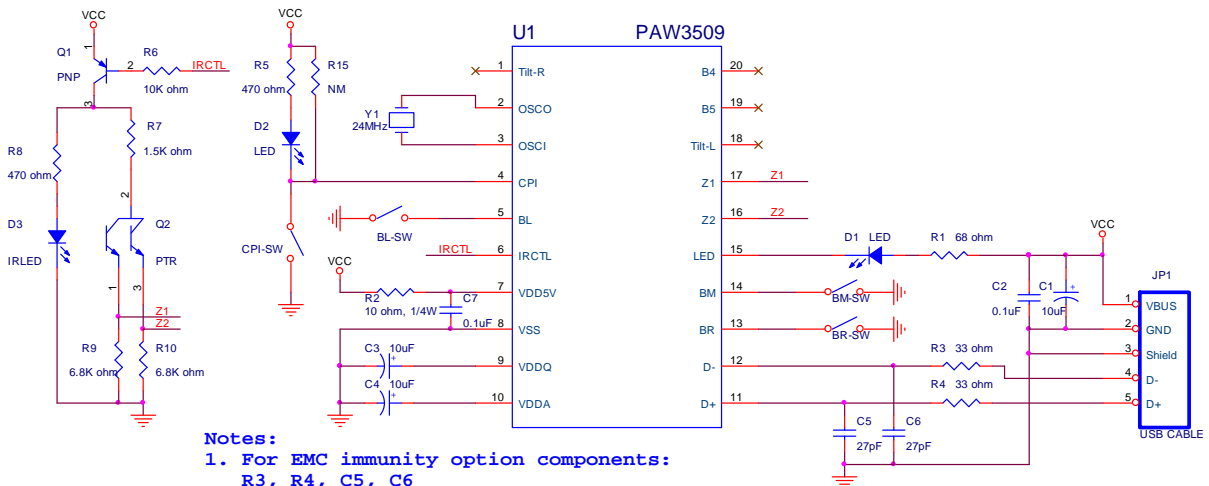

- Notes:**
1. For EMC immunity option components:
R3, R4, C5, C6
 2. Connector JP1 is suggested to has the pin sequence like:
VBUS, GND, Shield, D-, D+

Figure 5. 3D3B Application Circuit with IRPTR Zwheel.

Mouse SoC (4D5B, Mechanical)

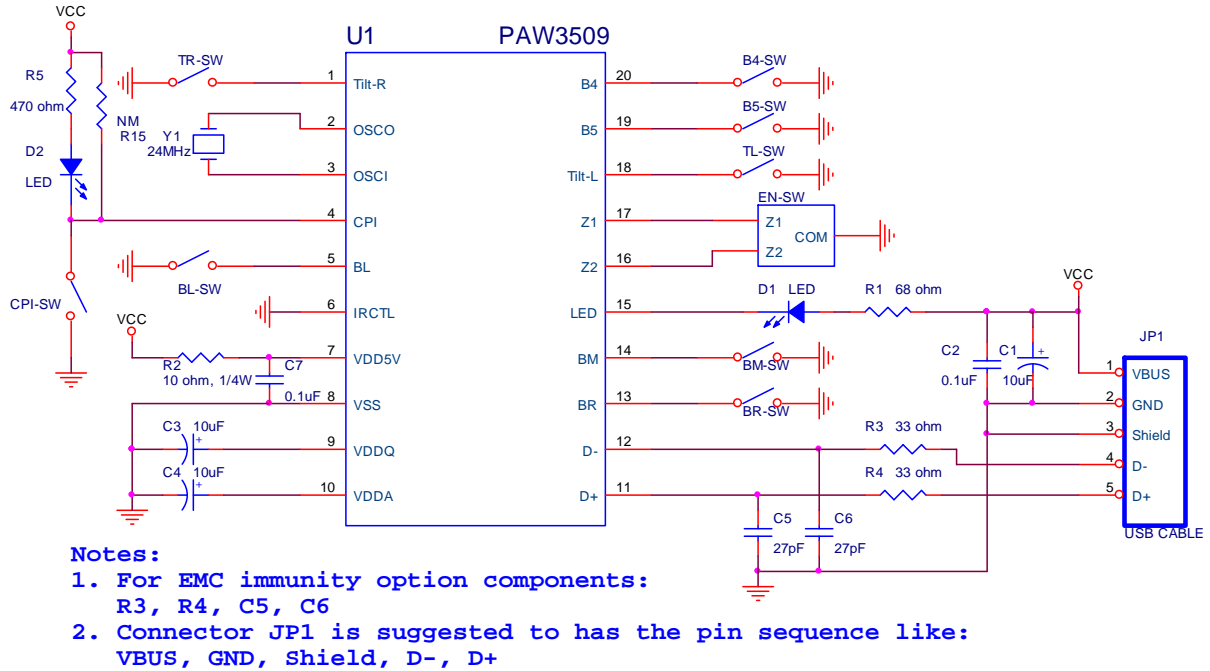

Figure 6. 4D5B Application Circuit with Mechanical Zwheel.

Mouse SoC (4D5B, IRPTR)

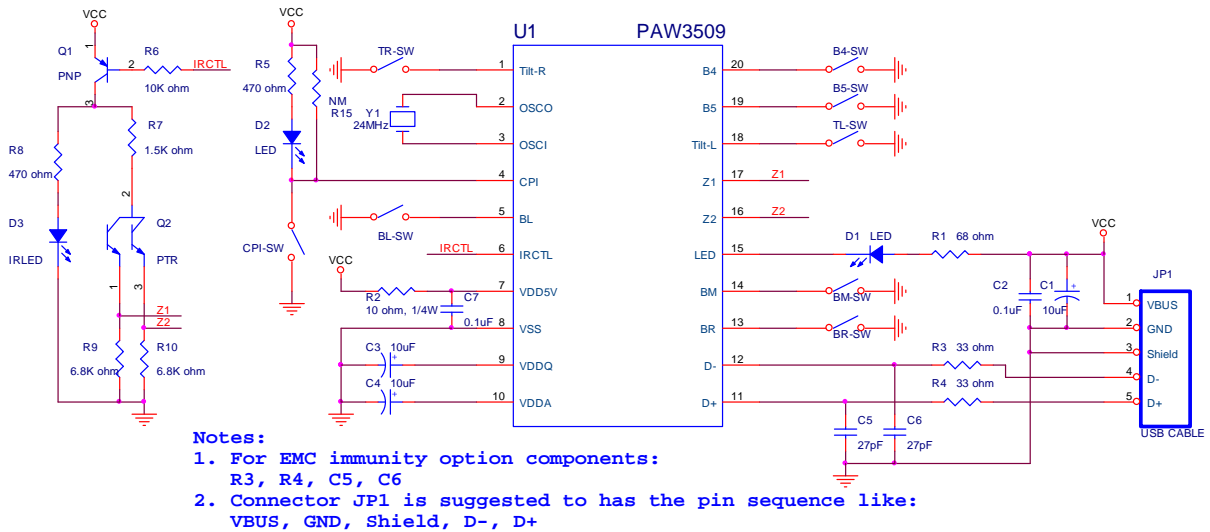

Figure 7. 4D5B Application Circuit with IRPTR Zwheel.