

PAW3552DB : USB/PS2 Optical Mouse SoC

General Description

The PAW3552DB is a highly integrated CMOS processed entry-level optical mouse single chip with USB and PS2 interfaces that serves as a non-mechanical motion estimation engine for implementing a computer mouse. The PAW3552DB also includes an internal RC oscillator to replace an external resonator for BOM cost reduction. The internal OTPs provides customers with flexibility of different configurations at manufacture side.

Key Features

- USB or PS2 interface (Programmable via OTP)
- Optical motion estimation technology
- Accurate motion estimation over a wide range of surfaces
- High speed motion detection up to 30 inches/sec
- Power saving mode during times of no movement
- Supports three buttons (L, M, R) and three axes (X, Y, Z) output
- Z-axis support mechanical input
- Internal RC oscillation without external resonator
- USB spec
 - Compliant to the USB specification version 2.00
 - Complete USB HID specs V1.11 compatibility
 - Integrated USB transceiver and 1.5Mbps USB serial interface engine
- OTP flexible configurations
 - Interface: USB / PS2
 - Sensor orientation: 0, +90, -90, 180
 - USB report format: 8bit / 16bit
 - USB P_string: xxxxxxxxxx USB Optical Mouse
 - USB PID/VID: xxxx / xxxx
 - CPI resolution : 800~2400

Applications

- Wired optical mouse applications
- Optical navigation systems

Key Parameters

Parameter	Value
Power Supply (V)	4.25V ~ 5.5V (from USB VBus)
Interface	USB or PS2
Speed	Up to 30 inches/sec
Acceleration	Up to 8g
Resolution (dpi)	800/1000(default)/1200/1600/2000/2400
Frame Rate (fps)	3300 frames/sec
Operating Current	10mA @Mouse moving (Normal) 5mA @Mouse not moving (Sleep) 480uA @USB suspend (Suspend)
Package	Staggered DIP8 type

Ordering Information

Part Number	Interface
PAW3552DB-VJXT	USB+PS2
PAW3552DB-VJWT	USB Only



For any additional inquiries, please contact us at <http://www.pixart.com/contact.asp>

Preliminary: This product is still under product development where the product specifications are subjected to change upon product release.

1.0 Introduction

1.1 Overview

The PAW3552DB supports three axes output of X, Y and Z, and three input buttons for Left (L), Middle (M) and Right (R) under USB and PS2 mode. It is a CMOS optical mouse single-chip sensor with USB or PS2 interface that serves as a non-mechanical motion estimation engine for implementing a computer mouse.

The PAW3552DB is housed in an 8-pin DIP package forming a complete navigation system with an optical lens assembly. It can track at the speed of motion up to 30 inches per second and comes with the programmable options of resolution which the default is 1000 counts per inch (CPI). The USB and PS2 mouse controller is built into the sensor as direct interface to the USB host, thus no external mouse controller is needed. The PAW3552DB can receive command and echo status or data format for both complete Universal Serial Bus (USB) Specifications V2.0 and USB HID Specifications V1.11 compatibility. The PAW3552DB is offering all the needs for a cost effective solution to support USB and PS2 mouse application.

Figure 1 shows the block diagram of PAW3552DB.

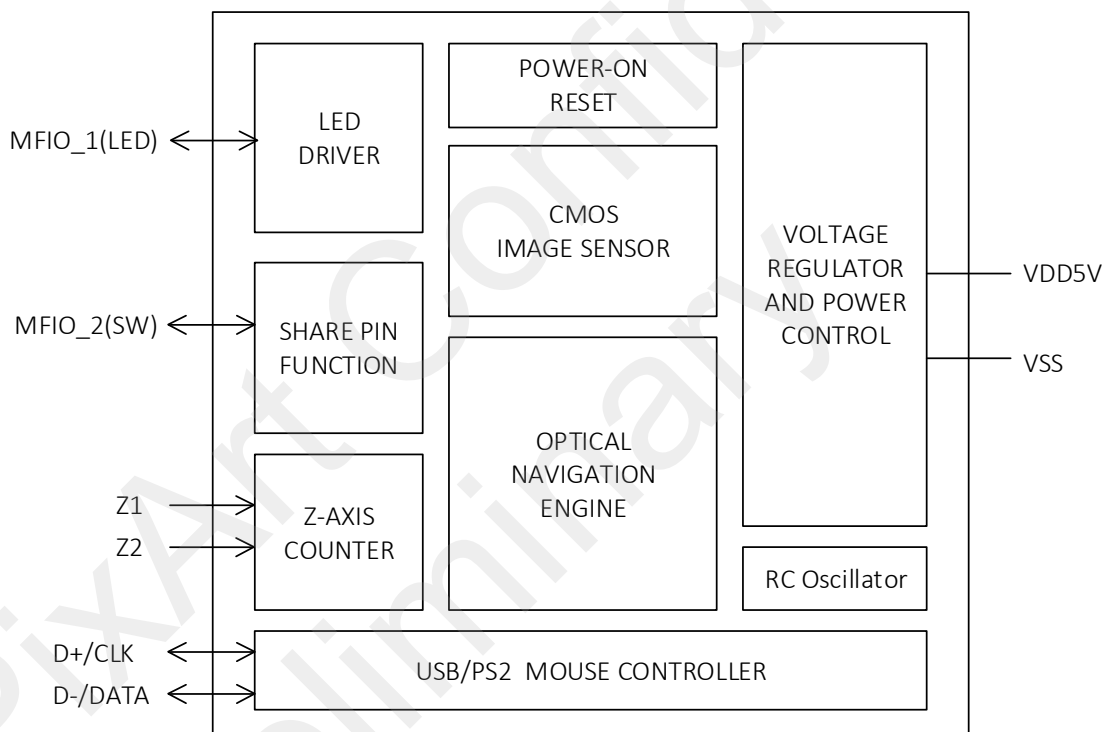

Figure 1. Block Diagram

1.2 Pin Description

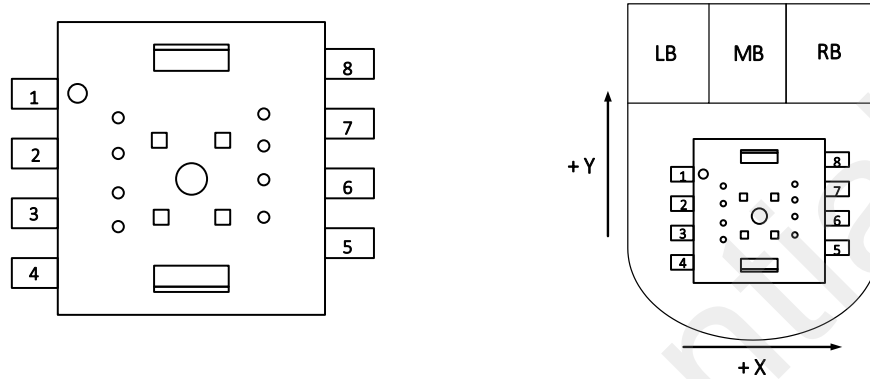

Figure 1. Top View Pinout

Table 1. Signal Pin Description

Pin #	Signal Name	Type	Definition
1	MFIO_1 (LED)	I/O	Share pin for LED power/BM
2	VDD5V	PWR	Chip power VDD, 5.0V
3	Z1	I/O	Z axis, support mechanical scroller input
4	Z2	I/O	Z axis, support mechanical scroller input
5	MFIO_2 (SW)	I/O	Share pin for LED control pin/BL/BR
6	VSS	GND	Chip ground
7	D-/DATA	I/O	USB D- or PS/2 mouse data line
8	D+/CLK	I/O	USB D+ or PS/2 mouse clock line

1.3 Sensor Orientations

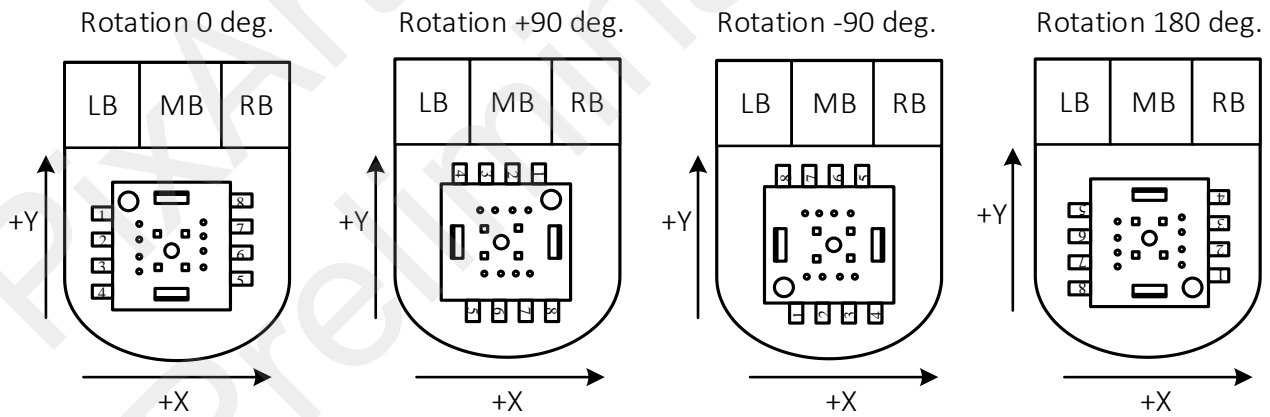
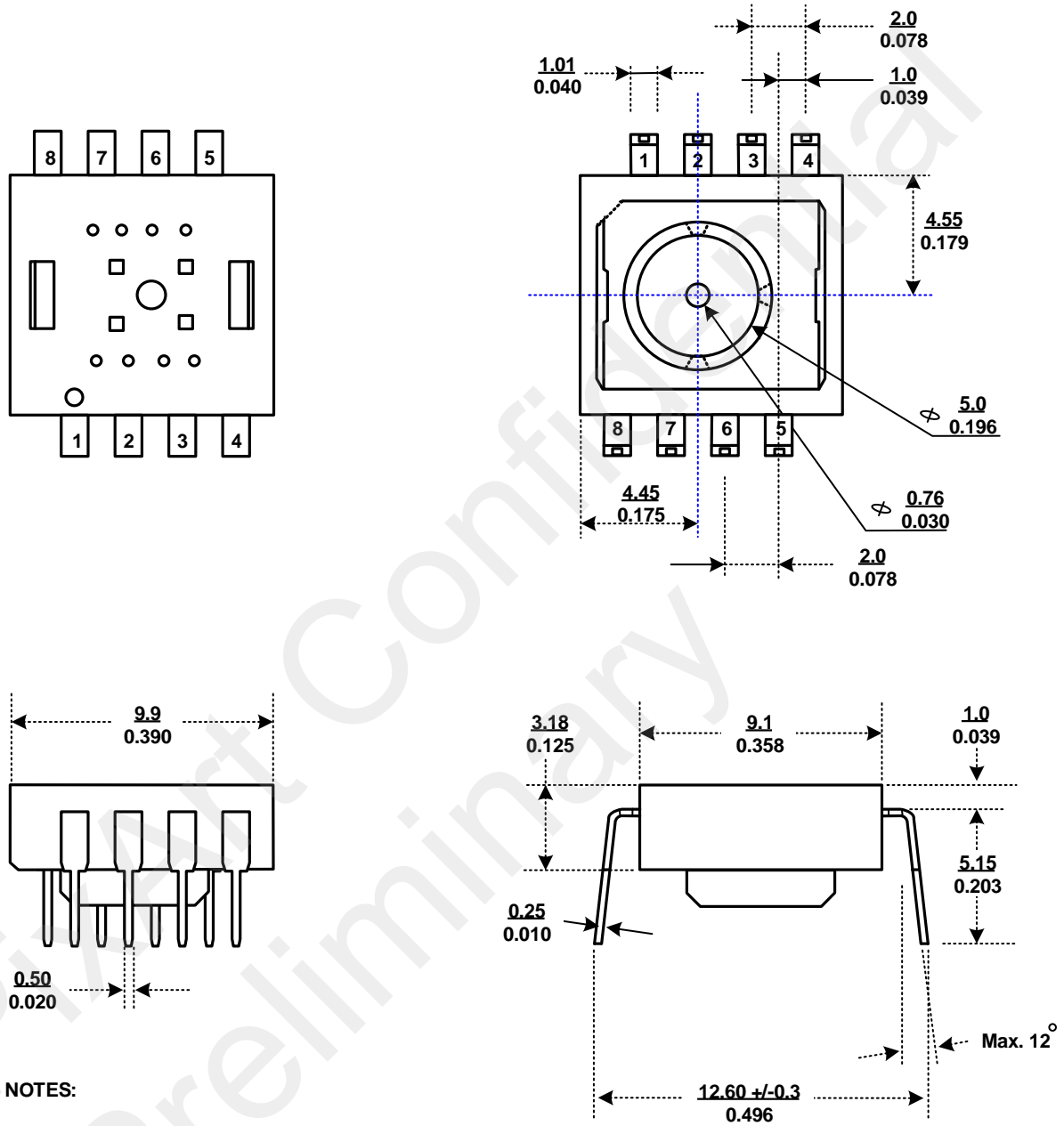

Figure 2. Types of Sensor Orientation

2.0 Mechanical Specifications

2.1 Package Mechanical Dimension



2.2 Assembly Drawing

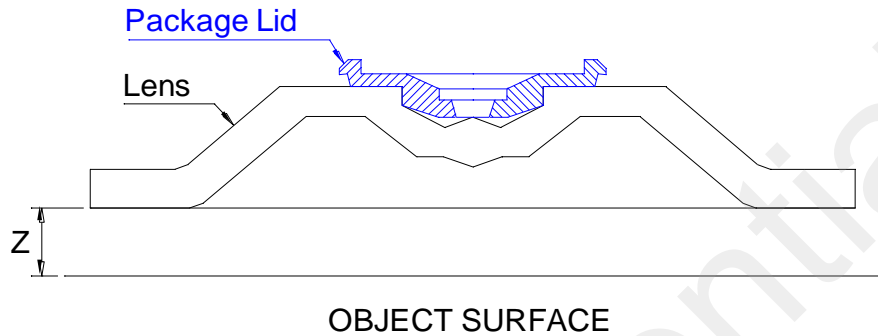

Figure 4. Distance from Lens Reference Plane to Surface

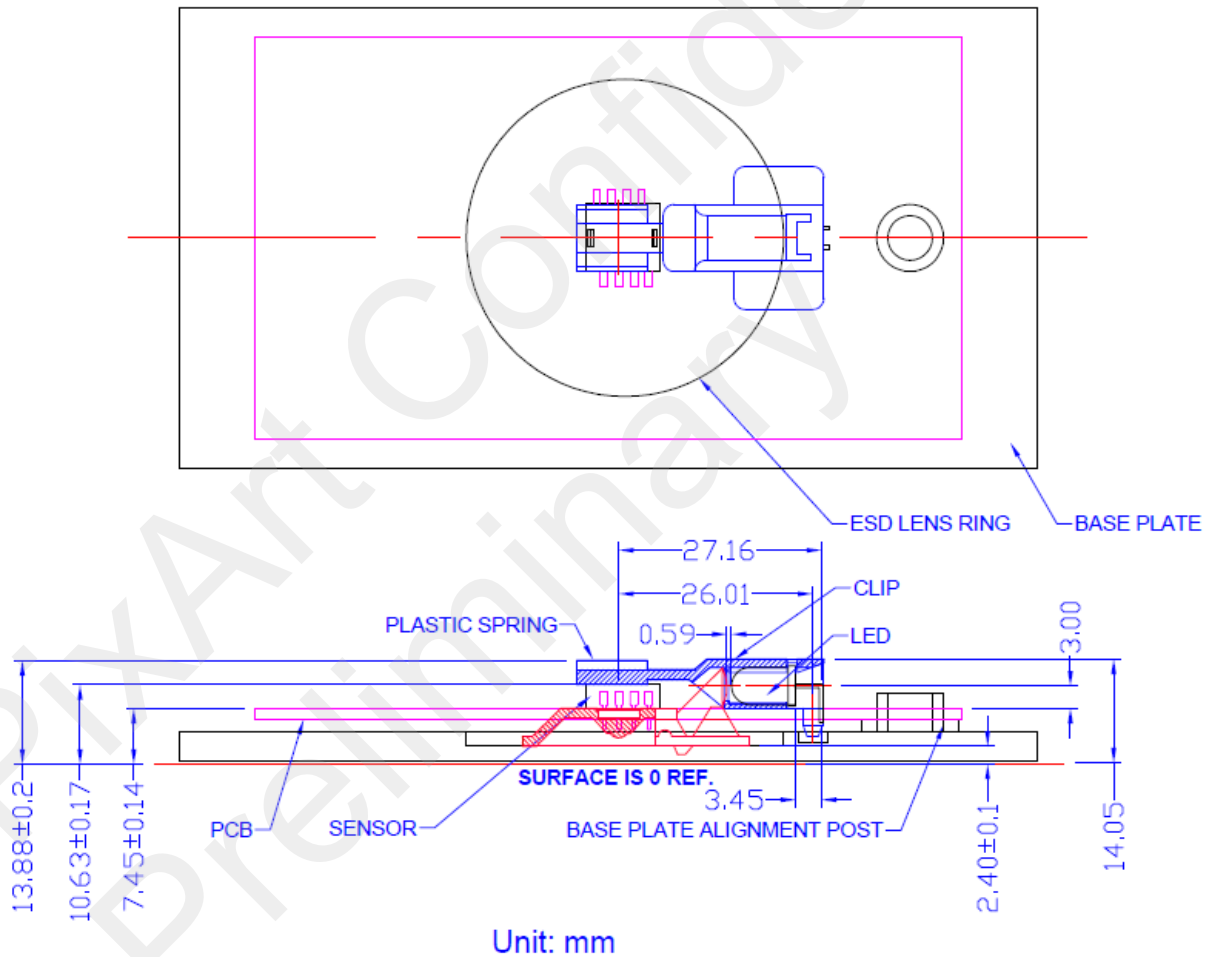

Figure 5. 2D Assembly

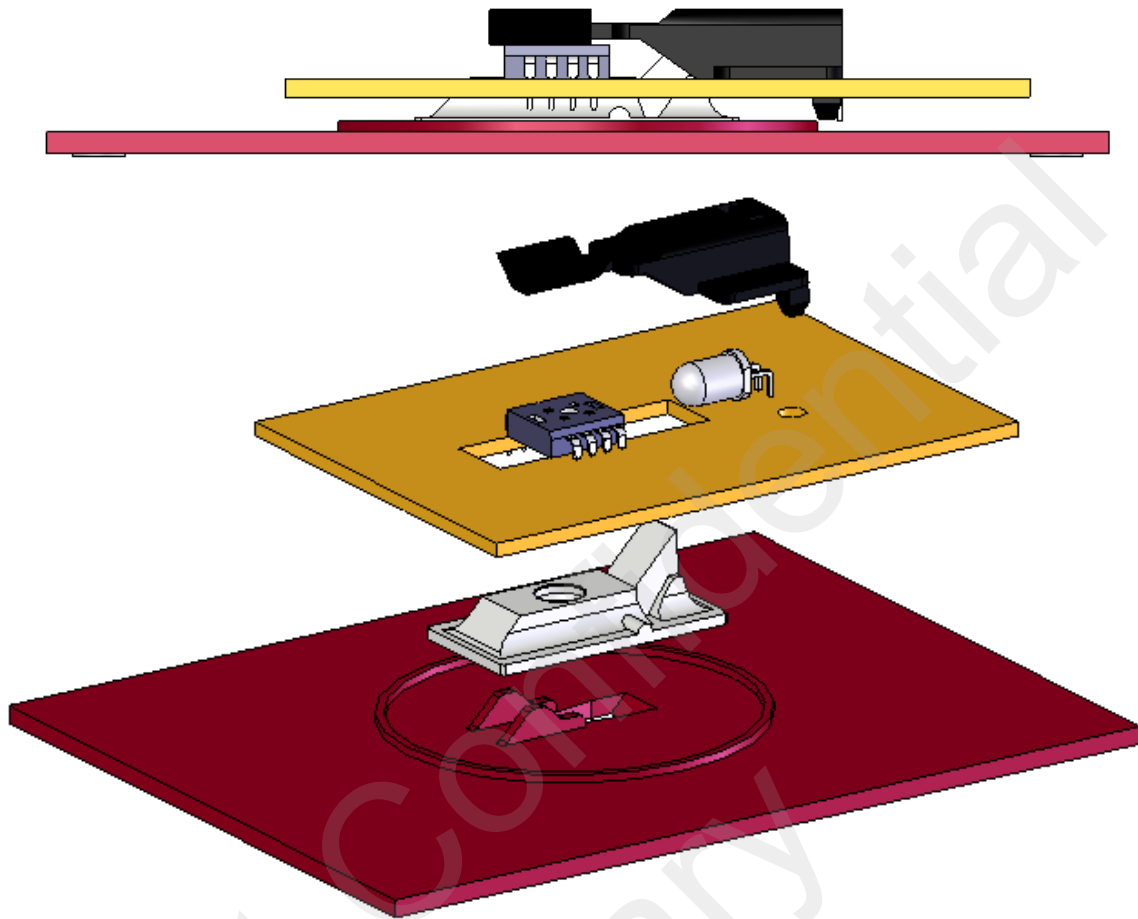
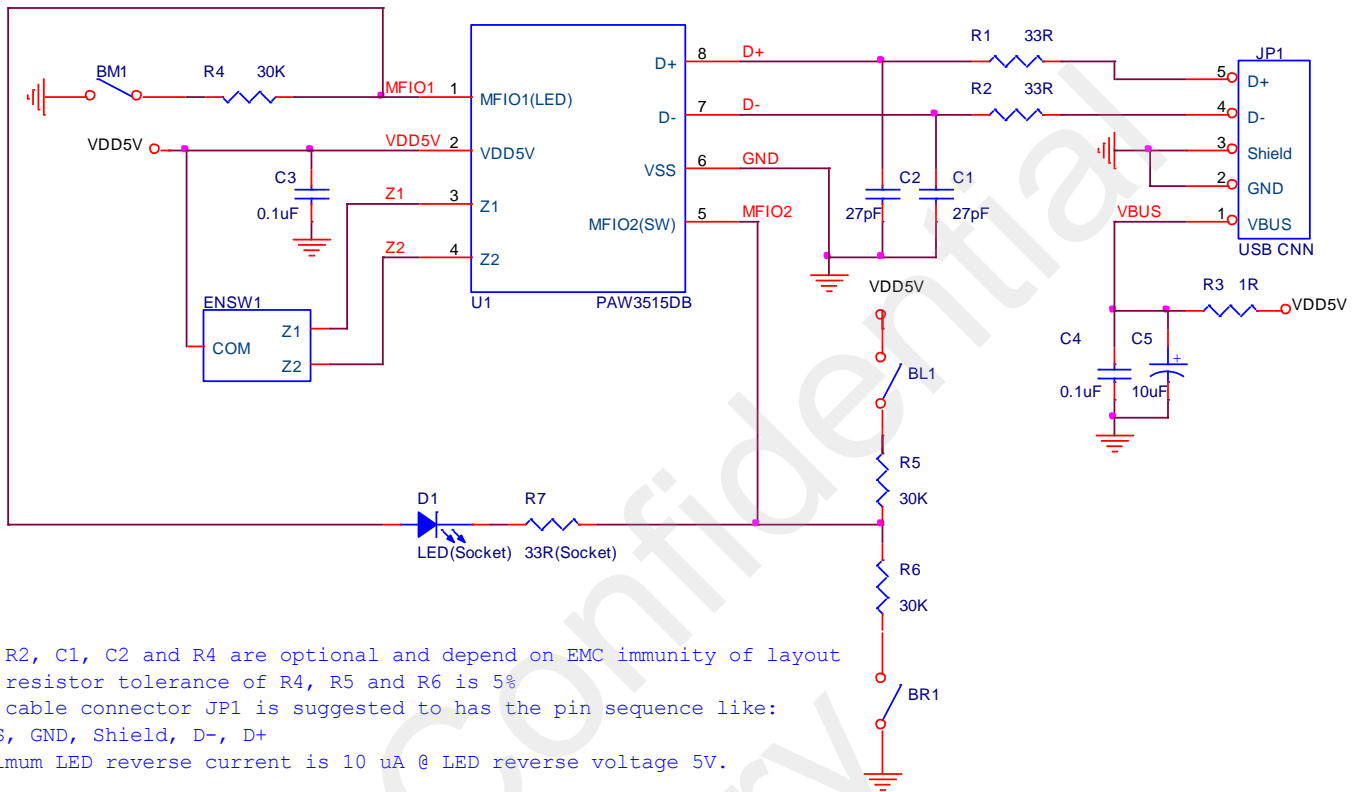

Figure 6. 3D Assembly for Mounting Instructions

3.0 Reference Schematics



- Note:
1. R1, R2, C1, C2 and R4 are optional and depend on EMC immunity of layout
 2. The resistor tolerance of R4, R5 and R6 is 5%
 3. USB cable connector JP1 is suggested to has the pin sequence like:
 VBUS, GND, Shield, D-, D+
 4. Maximum LED reverse current is 10 uA @ LED reverse voltage 5V.

Figure 7. Application Circuit for PAW3552DB

4.0 OTPs for Flexible Configurations

The PAW3552DB supports specific function programmable by using PixArt’s provided programmer. This can speed up project production to meet time to market.

Table 2. Programmable Configurations

Programmable Item	Specific Function	Remark
Interface	USB or PS2	
CPI resolution	800, 1000 (default), 1200, 1600, 2000, 2400	
Sensor rotation	0 (default), +90, -90, 180	
USB report format	8bit /16bit (default)	
USB P_string	USB Optical Mouse(default), xxxxxxxx USB Optical Mouse	x: Support 10 words totally. Specific character as 0~9, a~z, A~Z, ., space
USB PID	2510 (default), xxxx (custom PID)	x: Support any Hex code except FFFF.
USB VID	093A (default), xxxx (custom VID)	x: Support any Hex code except FFFF.