

**PAW3529DH-TXWA USB OPTICAL MOUSE SINGLE CHIP**
**General Description**

The PAW3529DH-TXWA is a CMOS process optical mouse sensor single chip with USB interface that serves as a non-mechanical motion estimation engine for implementing a computer mouse.

**Features**

- ❑ **USB interface**
- ❑ **Single power supply**
- ❑ **Optical motion estimation technology**
- ❑ **Complete 2-D motion sensor**
- ❑ **Accurate motion estimation over a wide range of surfaces**
- ❑ **High speed motion detection up to 37 inches/sec**
- ❑ **High resolution up to 2000 CPI**
- ❑ **Power saving mode during times of no movement**
- ❑ **Support up to FIVE buttons (R, M, L, 4, 5) and three axes (X, Y, Z) output**
- ❑ **Z-axis can support two kinds of scroller input (Mechanical or IRPTR)**
- ❑ **Support Tilt wheel: FOUR ways navigation with the scroll wheel up, down, left and right**
- ❑ **USB spec.**
  - **Complete Universal Serial Bus specification V1.1 compatibility**
  - **Complete USB HID specs V1.11 compatibility**
  - **Compliant to the USB specification version 2.00**
  - **Integrated USB transceiver and 1.5Mbps USB serial interface engine**
  - **16-bit X/Y report format**
- ❑ **One dedicated pin for CPI switch and indication**
- ❑ **Flexibility for device type configuration.**
  - **Interface: USB / PS2**
  - **USB type: 4D5B, 3D3B**
  - **CPI resolution: 400 ~ 2000**
  - **CPI switch type: 4 types available**
  - **Sensor rotation: 0, +90(clockwise), -90, 180**

**Key Specification**

<b>Power Supply</b>	<b>Wide operating supply range 4.25V ~ 5.5V</b>
<b>Interface</b>	<b>USB</b>
<b>Optical Lens</b>	<b>1:1</b>
<b>System Clock</b>	<b>24.000 MHz</b>
<b>Speed</b>	<b>37 inches/sec</b>
<b>Acceleration</b>	<b>15g</b>
<b>Resolution</b>	<b>1000(Default)/1600/600 CPI</b>
<b>CPI Switch Level</b>	<b>1000 -&gt; 1600 -&gt; 600 -&gt; 1000 ... (Default)</b>
<b>Frame Rate</b>	<b>4000 frames/sec</b>
<b>Operating Current</b>	<b>10mA @Mouse moving (Normal) 5mA @Mouse not moving (Sleep) 480uA @USB suspend (Suspend)</b>
<b>Package</b>	<b>Shrunk DIP20</b>

**Ordering Information**

<b>Bundle Part Number</b>	<b>Device Type</b>	<b>Interface</b>	<b>Roller</b>
PAW3529DH-TXWA	4D5B	USB (LS,16-bitXY)	Mechanical/IRPTR
PNLR-00012	Specular Lens		

**1. Pin Configuration**

**1.1 Pin Description**

Pin #	Name	Type	Definition
1	Tilt-R	I	Tilt wheel button right key input.
2	OSCOUT	O	Oscillator output.
3	OSCIN	I	Oscillator input.
4	CPI	I/O	CPI switch input and indication (PWM) output.
5	BL	I	Button left key input.
6	IRCTL	I/O	Mechanical(L)/IRPTR(H) trapping input and IRPTR power control output.
7	VDD5V	PWR	Chip power VDD 5.0V.
8	VSS	GND	Chip ground.
9	VDDQ	PWR	I/O voltage reference output.
10	VDDA	PWR	Analog voltage reference output.
11	D+	I/O	USB D+.
12	D-	I/O	USB D-.
13	BR	I	Button right key input.
14	BM	I	Button middle key input.
15	LED	O	LED control.
16	Z2	I	Z-axis mechanical / IRPTR scroller input.
17	Z1	I	Z-axis mechanical / IRPTR scroller input.
18	Tilt-L	I	Tilt wheel button left key input.
19	B5	I	Button 5th key input.
20	B4	I	Button 4th key input.

**1.2 Pin Assignment for Sensor Rotate 0°**

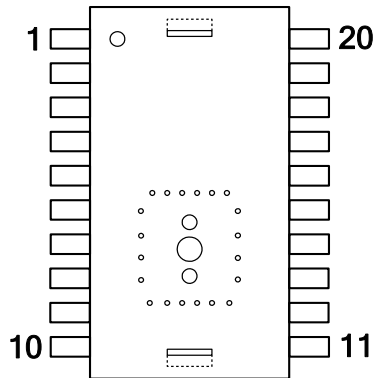

Figure 1. Top View Pinout

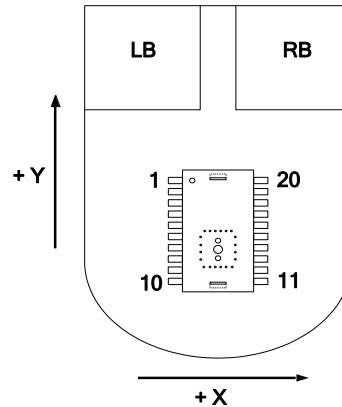

Figure 2. Top View of Mouse

All rights strictly reserved any portion in this paper shall not be reproduced, copied or transformed to any other forms without permission.

專利公示：本產品業經本公司獲得台灣專利第 509867, 530489, 529309, 560179, 526662, 554497, I230890, I287732 號專利在案。

PixArt Imaging Inc.

E-mail: [fae\\_service@pixart.com.tw](mailto:fae_service@pixart.com.tw)

### 2. Block Diagram and Operation

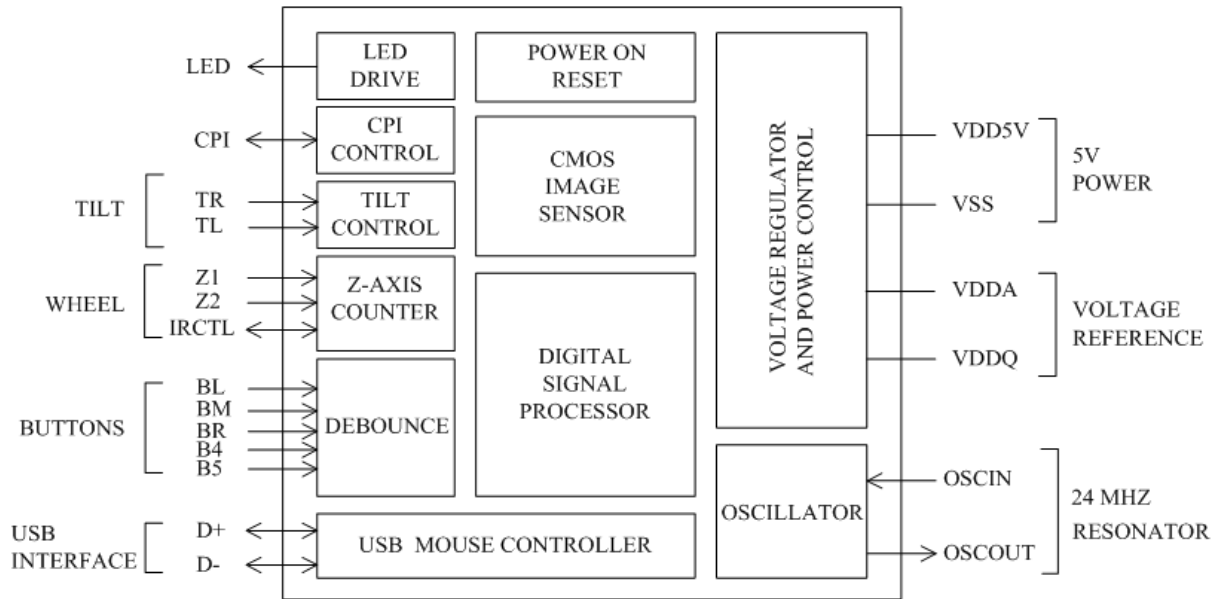

Figure 3. Block Diagram

The PAW3529DH-TXWA supports X, Y, Z three axes, and L, R, M, 4, 5 five buttons under USB mode. It is a CMOS process optical mouse sensor single chip with USB interface that serves as a non-mechanical motion estimation engine for implementing a computer mouse.

The PAW3529DH-TXWA is in a 20-pin optical package and comes with the resolution of 1000/1600/600 counts per inch (CPI) and the rate of motion up to 37 inches per second. It includes USB interface so that no mouse controller is needed to interface through USB. The PAW3529DH-TXWA can receive command and echo status or data format, both complete Universal Serial Bus<sup>®</sup> spec V1.1 and USB HID spec V1.11 compatibility. It is also a cost effective solution to support USB Mouse.

### 3. Specifications

#### 3.1 Absolute Maximum Ratings

Exposure to absolute maximum rating may affect device reliability.

Symbol	Parameter	Min.	Max.	Unit	Notes
T <sub>STG</sub>	Storage Temperature	-40	85	°C	
TA	Operating Temperature	-15	55	°C	
	Lead Solder Temp		260	°C	For 10 seconds, 1.6 mm below seating plane.
ESD			2	kV	All pins, human body model MIL 883 Method 3015
V <sub>DC</sub>	DC Supply Voltage	-0.5	V <sub>DD</sub> +0.5	V	
V <sub>IN</sub>	DC Input Voltage	-0.5	V <sub>DD</sub> +0.5	V	IRCTL
		-0.5	V <sub>DDQ</sub> +0.5	V	All I/O pins except IRCTL

#### 3.2 Recommend Operating Condition

Symbol	Parameter	Min.	Typ.	Max.	Unit	Notes
T <sub>A</sub>	Operating Temperature	0		40	°C	
V <sub>DD</sub>	Power Supply Voltage	4.25	5.0	5.5	V	
V <sub>Npp</sub>	Supply Noise			100	mV	Peak to peak within 10K~80 MHz
Z	Distance from Lens Reference Plane to Surface	2.3	2.4	2.5	mm	Refer to Figure 7.
R	Resolution		1000		CPI	
A	Acceleration			15	g	
F <sub>CLK</sub>	Clock Frequency		24		MHz	
FR	Frame Rate		4000		frames/sec	
S	Speed			37	inches/sec	37 inches/sec @ 1000CPI, A4 paper surface. 20 inches/sec @ 1000CPI, Black surface.

### 3.3 AC Electrical Characteristics

Electrical characteristics under recommended operating conditions. Typical values at 25 °C,  $V_{DD} = 5.0$  V,  $F_{CLK} = 24$  MHz

Symbol	Parameters	Min.	Typ.	Max.	Unit	Notes
$T_{pwm}$	CPI PWM Period	-	1	-	ms	Refer to Figure 4.
$T_d$	CPI PWM Low Duty Cycle Time	-	0	-	ms	@0% Low duty
		-	0.2	-	ms	@20% Low duty
		-	0.9	-	ms	@90% Low duty
$T_{bd}$	Mouse Button Debounce Time	-	10.24	-	ms	Refer to Figure 5.
$T_{wd}$	Mouse Z Wheel Debounce Time	-	16	-	us	IRPTR
		-	1.024	-	ms	Mechanical
$T_w$	Mouse Z Wheel Time	1143	-	-	us	Refer to Figure 6.

### 3.4 DC Electrical Characteristics

Electrical characteristics under recommended operating conditions. Typical values at 25 °C,  $V_{DD} = 5.0$  V,  $F_{CLK} = 24$  MHz.

Symbol	Parameter	Min.	Typ.	Max.	Unit	Notes
<b>Type: USB Mouse PWR</b>						
$I_{DD}$	Supply Current Mouse moving (Normal)	-	10	-	mA	
$I_{DD}$	Supply Current Mouse not moving (Sleep)	-	5	-	mA	
$I_{DD}$	Supply Current USB suspend current	-	-	480	uA	
<b>Type: BM, BR, BL, Z2, Z1, B4, B5, TR, TL</b>						
$R_{PH1}$	Internal Pull Up Resistance	-	30	-	Kohm	BM, BR, BL
$R_{PH2}$	Internal Pull Up Resistance	-	40	-	Kohm	Z2, Z1
$R_{PH3}$	Internal Pull Up Resistance	-	50	-	Kohm	B4, B5, TR, TL
$V_{IH}$	Input High Voltage	$V_{DDQ} * 0.7$	-	-	V	
$V_{IL}$	Input Low Voltage	-	-	$V_{DDQ} * 0.3$	V	
<b>Type: USB D-</b>						
$R_{PH4}$	Internal Pull Up Resistance	-	1.5	-	Kohm	
<b>Type: LED</b>						
$V_{OL}$	Output Low Voltage	-	-	0.5	V	@ $I_{OL} = 30$ mA
<b>Type: CPI</b>						
$V_{IH}$	Input High Voltage	$V_{DDQ} * 0.7$	-	-	V	
$V_{IL}$	Input Low Voltage	-	-	$V_{DDQ} * 0.3$	V	
$V_{OL}$	Output Low Voltage	-	-	0.5	V	@ $I_{OL} = 30$ mA
<b>Type: IRCTL</b>						
$V_{OH}$	Output High Voltage	-	VDD	-	V	IRCTL = VDD @ USB suspend if IRCTL trapping to IRPTR.
<b>Type: VDDQ</b>						
VDDQ	I/O Voltage Reference	-	3.3	-	V	

### 3.5 CPI Switch and Indication

The PAW3529DH-TXWA supports CPI switch function that allows user change resolution between 1000/1600/600 through pressing the CPI button. And the corresponding indications will be shown by using PWM output on the same pin, i.e. outputting different duty cycles for different resolution at fixed 1 KHz frequency. It will cause the different brightness on LED. The CPI indication (PWM) output timing and relationship between resolution and duty cycle are as follows,

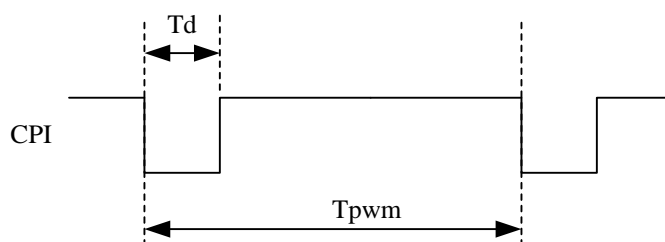

Figure 4. CPI Indication Timing

Resolution	PWM Low Duty	LED Status
1000 cpi	20%	Less brightness
1600 cpi	90%	Much brightness
600 cpi	0%	Dark

#### 3.5.1 Available CPI Configuration

The PAW3529DH-TXWA supports flexible CPI configuration for changing default resolution. The available resolutions are as follows. Note that 1000 is default value.

Available resolution (Unit: count/inch)			
400	500	600	800
<b>1000(default)</b>	1200	1600	2000

#### 3.5.2 Available CPI Switch Configuration

The PAW3529DH-TXWA supports flexible CPI switch configuration for changing switch level and indicator behavior. With this configuration, must combination support 3-level switch. However, at boundary default resolution, it supports only 2-level or 1-level switch. The available switch types are as follows. Note that 1000-1600-600 is default type.

Available switch level and indicator behavior Look-up Table											
Default resolution at 400 CPI											
Type0	Switch	PWM	Type1	Switch	PWM	Type2	Switch	PWM	Type3	Switch	PWM
	400	20%		400	20%		400	0%		400	0%
	600	90%		500	90%		600	20%		600	20%

All rights strictly reserved any portion in this paper shall not be reproduced, copied or transformed to any other forms without permission.

專利公示：本產品業經本公司獲得台灣專利第 509867, 530489, 529309, 560179, 526662, 554497, I230890, I287732 號專利在案。

	N/A	N/A		N/A	N/A		800	90%		1000	90%
Default resolution at <u>500 CPI</u>											
Type0	Switch	PWM	Type1	Switch	PWM	Type2	Switch	PWM	Type3	Switch	PWM
	500	20%		500	20%		500	0%		500	0%
	800	90%		600	90%		800	20%		800	20%
	400	0%		400	0%		1000	90%		1200	90%
Default resolution at <u>600 CPI</u>											
Type0	Switch	PWM	Type1	Switch	PWM	Type2	Switch	PWM	Type3	Switch	PWM
	600	20%		600	20%		600	0%		600	0%
	1000	90%		800	90%		1000	20%		1000	20%
	400	0%		500	0%		1200	90%		1600	90%
Default resolution at <u>800 CPI</u>											
Type0	Switch	PWM	Type1	Switch	PWM	Type2	Switch	PWM	Type3	Switch	PWM
	800	20%		800	20%		800	0%		800	0%
	1200	90%		1000	90%		1200	20%		1200	20%
	500	0%		600	0%		1600	90%		2000	90%
Default resolution at <u>1000 CPI (default)</u>											
Type0 (def- ault)	Switch	PWM	Type1	Switch	PWM	Type2	Switch	PWM	Type3	Switch	PWM
	1000	20%		1000	20%		1000	0%		1000	0%
	1600	90%		1200	90%		1600	20%		1600	20%
	600	0%		800	0%		2000	90%		2000	90%

Default resolution at <u>1200 CPI</u>											
Type0	Switch	PWM	Type1	Switch	PWM	Type2	Switch	PWM	Type3	Switch	PWM
	1200	20%		1200	20%		1200	0%		1200	0%
	2000	90%		1600	90%		2000	20%		2000	20%
	800	0%		1000	0%		N/A	N/A		N/A	N/A
Default resolution at <u>1600 CPI</u>											
Type0	Switch	PWM	Type1	Switch	PWM	Type2	Switch	PWM	Type3	Switch	PWM
	1600	20%		1600	20%		1600	0%		1600	0%
	2000	90%		2000	90%		2000	20%		2000	20%
	1000	0%		1200	0%		N/A	N/A		N/A	N/A
Default resolution at <u>2000 CPI</u>											
Type0	Switch	PWM	Type1	Switch	PWM	Type2	Switch	PWM	Type3	Switch	PWM
	2000	20%		2000	20%		2000	0%		2000	0%
	1200	0%		1600	0%		N/A	N/A		N/A	N/A
	N/A	N/A		N/A	N/A		N/A	N/A		N/A	N/A

### 3.6 Button and Z-Wheel Debounce Timing

Buttons and Z wheel of PAW3529DH-TXWA include detect and debounce function which are hardware implemented. When press button input signals need keeping low level up to 9.216ms. Button function just can catch data otherwise debounce function will judge it is bounce issue. When scroll Z wheel input signals need keeping turning level up to 0.896ms. Z wheel function just can catch data otherwise debounce function will judge it is bounce issue. And the hardware sample rate is 2us so if bounce time is less than 2us the debounce function will ignore it. Following the below specifications Buttons and Z wheel will work normally.

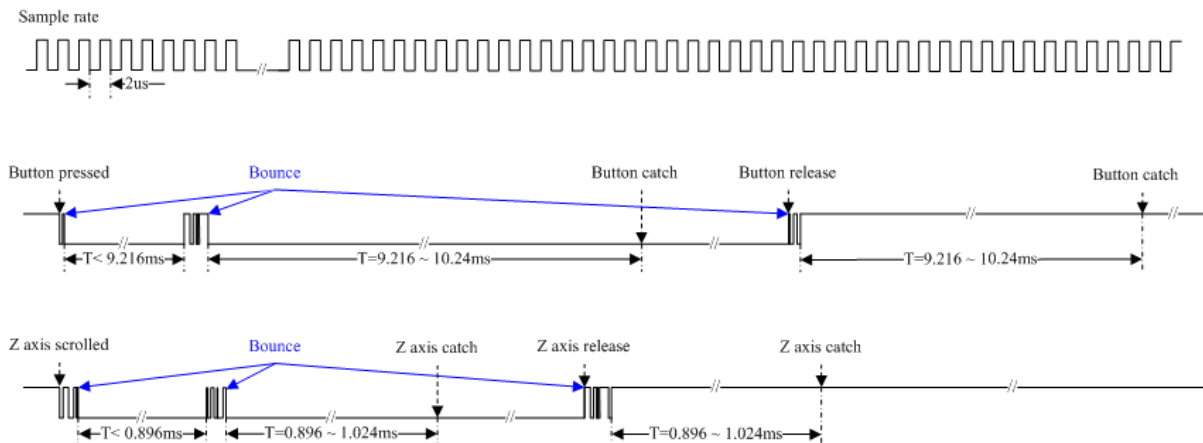
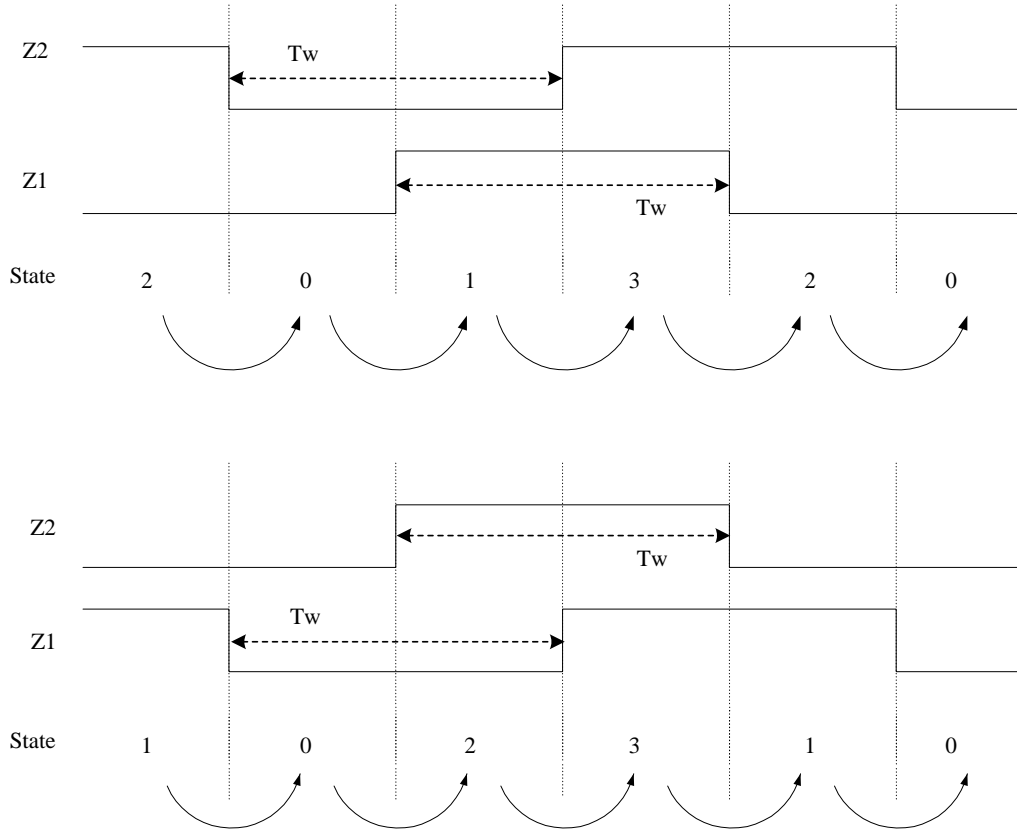

Figure 5. Debounce Timing



3.7 Z-axis Waveform



STATE	Z-axis input	
	Z2	Z1
0	0	0
1	0	1
2	1	0
3	1	1

Figure 6. Z-axis Waveform

4. Z and 2D/3D Assembly

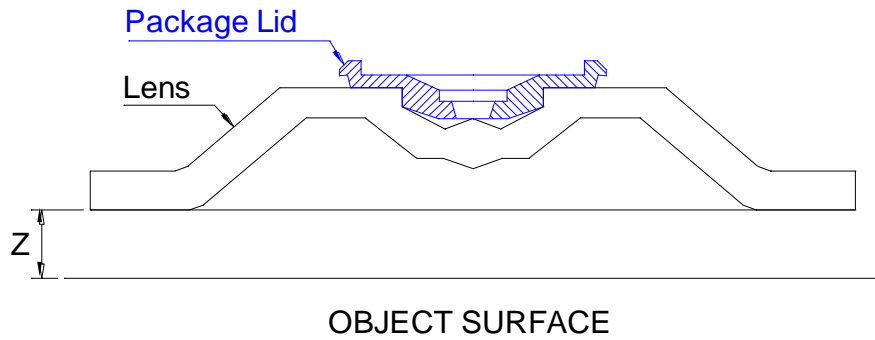

Figure 7. Distance from Lens Reference Plane to Surface

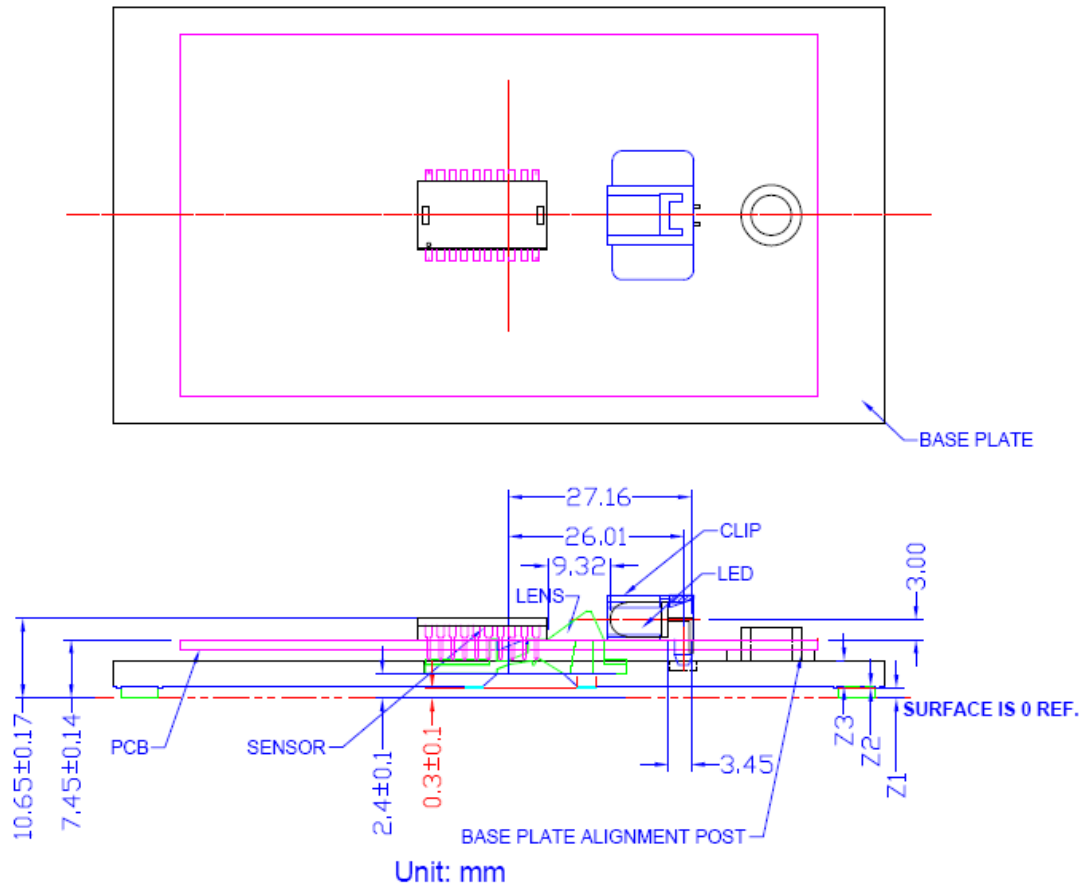

Figure 8. 2D Assembly

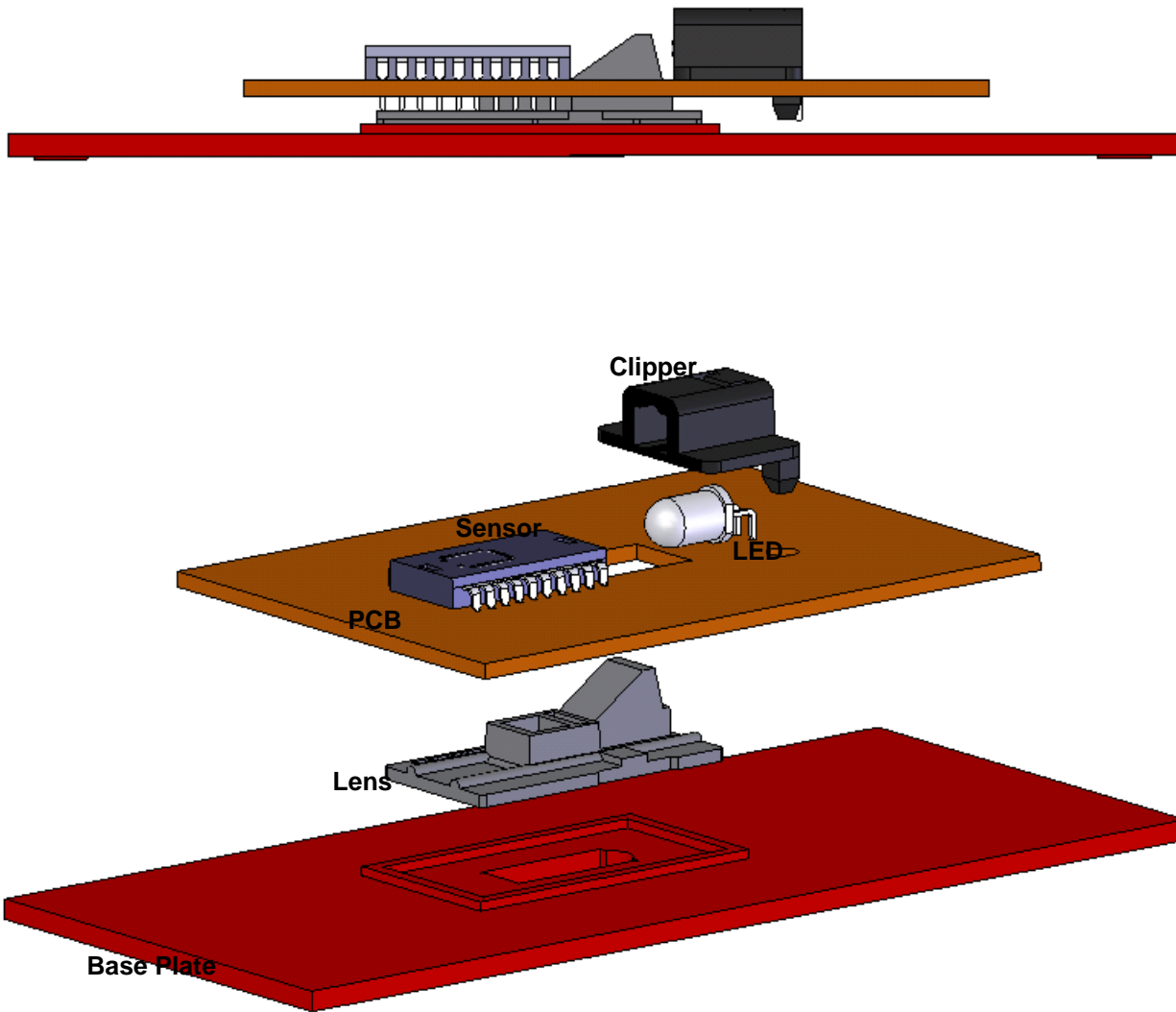

Figure 9. 3D Assembly for Mounting Instructions with Trim Lens

**5. USB Interface**

**5.1 USB Command Set Description (USB Descriptor)**

The USB HOST detects USB mouse device plug-in and assigns a new unique address to the USB mouse device, then asking USB mouse device for information about the device description, configuration description, and assigning a configuration value for USB mouse device during enumeration period. After enumeration, the USB mouse device is able to transfer motion and button value to the USB host.

■ USB Descriptors for 3D3B, 16-Bit XY Device

Descriptor Type	Byte	Byte	Byte	Byte	Byte	Byte	Byte	Byte
Device Descriptor (18 bytes)	12	01	10	01	00	00	00	08
	3A	09	16	25	00	01	00	02
	00	01						
Configuration Descriptor (9 bytes)	09	02	22	00	01	01	04	A0
	32							
Interface Descriptor (9 bytes)	09	04	00	00	01	03	01	02
	00							
Human Interface Device Descriptor (9 bytes)	09	21	11	01	00	01	22	4F
	00							
Endpoint Descriptor (7 bytes)	07	05	81	03	08	00	0A	
Human Interface Device Report Descriptor (79 bytes, 3D3B, 16-bit XY)	05	01	09	02	A1	01	09	01
	A1	00	05	09	19	01	29	03
	15	00	25	01	95	03	75	01
	81	02	95	01	75	05	81	03
	06	00	FF	09	40	95	02	75
	08	15	81	25	7F	81	02	05
	01	09	38	15	81	25	7F	75
	08	95	01	81	06	09	30	09
	31	16	01	80	26	FF	7F	75
	10	95	02	81	06	C0	C0	
Language String Descriptor (4 bytes)	04	03	09	04				
Manufacture String Descriptor								
Product String Descriptor	USB OPTICAL MOUSE							
Configuration String Descriptor	HID-compliant MOUSE							

■ USB Descriptors for 4D5B, 16-Bit XY Device

Descriptor Type	Byte	Byte	Byte	Byte	Byte	Byte	Byte	Byte
Device Descriptor (18 bytes)	12	01	10	01	00	00	00	08
	3A	09	21	25	00	01	00	02
	00	01						
Configuration Descriptor (9 bytes)	09	02	22	00	01	01	04	A0
	32							
Interface Descriptor (9 bytes)	09	04	00	00	01	03	01	02
	00							
Human Interface Device Descriptor (9 bytes)	09	21	11	01	00	01	22	4F
	00							
Endpoint Descriptor (7 bytes)	07	05	81	03	07	00	0A	
Human Interface Device Report Descriptor (79 bytes)	05	01	09	02	A1	01	05	09
	19	01	29	05	15	00	25	01
	95	05	75	01	81	02	95	01
	75	03	81	03	05	01	09	01
	A1	00	09	30	09	31	16	01
	80	26	FF	7F	75	10	95	02
	81	06	C0	09	38	15	81	25
	7F	75	08	95	01	81	06	05
	0C	0A	38	02	15	81	25	7F
Language String Descriptor (4 bytes)	04	03	09	04				
Manufacture String Descriptor								
Product String Descriptor	USB OPTICAL MOUSE							
Configuration String Descriptor	HID-compliant MOUSE							

## 5.2 USB Data Report Format

The USB report has two data formats, depending on boot or report protocol is selected. One kind of data format is the boot protocol used in legacy environment as 5.2.1. The other kind of data format is USB report protocol format which includes Z-wheel movement data as 5.2.2. If the Z-wheel is scrolled upward the corresponding report data will be 01H. If the Z-wheel is scrolled downward the corresponding report data will be FFH. And the report data will be 00H if Z-wheel is idle.

### 5.2.1 USB Boot Protocol for Legacy Operation

Byte	Bit	Symbol	Description
1	7 - 3	NC	Reserved
	2	BM	1 = Middle button pressed
	1	BR	1 = Right button pressed
	0	BL	1 = Left button pressed
2	7 - 0	X7 - X0	X data (X7 - X0). A positive value indicates device was moved to the right; a negative value indicates device was move to the left. Bit 0 = LSB.
3	7 - 0	Y7 - Y0	Y data (Y7 - Y0). A positive value indicates device was moved upward; a negative value indicates device was moved downward. Bit 0 = LSB.

### 5.2.2 USB Report Protocol

- USB report protocol for 3D3B, 16-Bit XY Device.

Byte	Bit	Symbol	Description
1	7 - 5	NC	Reserved
	4	B5	Reserved
	3	B4	Reserved
	2	BM	1 = Middle button pressed
	1	BR	1 = Right button pressed
	0	BL	1 = Left button pressed
2	7 - 0	X7 - X0	X data (D7 - D0). A positive value indicates motion to the right; a negative value indicates motion to the left. Bit 0 = LSB.
3	7 - 0	Y7 - Y0	Y data (D7 - D0). A positive value indicates device motion upward; a negative value indicates motion downward. Bit 0 = LSB.
4	7 - 0	Z7 - Z0	Z-wheel motion data (D7 - D0). A positive value indicates device motion upward; a negative value indicates motion downward. The Z7 - Z0 limit value is $\pm 7$ . Bit 0 = LSB.
5	7 - 0	X7 - X0	X data (D7 - D0). A positive value indicates motion to the right; a negative value indicates motion to the left. Bit 0 = LSB.
6	7 - 0	X15 - X8	X data (D15 - D8). A positive value indicates motion to the right; a negative value indicates motion to the left. Bit 0 = LSB.
7	7 - 0	Y7 - Y0	Y data (D7 - D0). A positive value indicates device motion upward; a negative value indicates motion downward. Bit 0 = LSB.
8	7 - 0	Y15 - Y8	Y data (D15 - D8). A positive value indicates device motion upward; a negative value indicates motion downward. Bit 0 = LSB.

■ USB report protocol for 4D5B, 16-Bit XY Device.

Byte	Bit	Symbol	Description
1	7 - 5	NC	Reserved
	4	B5	1 = 5th button pressed
	3	B4	1 = 4th button pressed
	2	BM	1 = Middle button pressed
	1	BR	1 = Right button pressed
	0	BL	1 = Left button pressed
2	7 - 0	X7 - X0	X data (X7 - X0). A positive value indicates device was moved to the right; a negative value indicates device was move to the left. Bit 0 = LSB.
3	7 - 0	X15 - X8	X data (X15 - X8). A positive value indicates device motion to the right; a negative value indicates motion to the left.
4	7 - 0	Y7 - Y0	Y data (Y7 - Y0). A positive value indicates device was moved upward; a negative value indicates device was moved downward. Bit 0 = LSB.
5	7 - 0	Y15 - Y8	Y data (Y15 - Y8). A positive value indicates device motion upward; a negative value indicates device was moved downward.
6	7 - 0	Z7 - Z0	Z-wheel report data (Z7 - Z0). A positive value indicates z-wheel was scrolled upward; a negative value indicates z-wheel was scrolled downward. The Z7 - Z0 limit value is $\pm 7$ . Bit 0 = LSB.
7	7 - 0	W7 - W0	Tilt wheel report data (W7 - W0). A positive value indicates tilt wheel was scrolled right; a negative value indicates tilt wheel was scrolled left. The W7 - W0 limit value is $\pm 1$ . Bit 0 = LSB.

6. Referencing Application Circuit

6.1 3D3B/4D5B Application Circuit

Mouse SoC (3D3B, Mechanical)

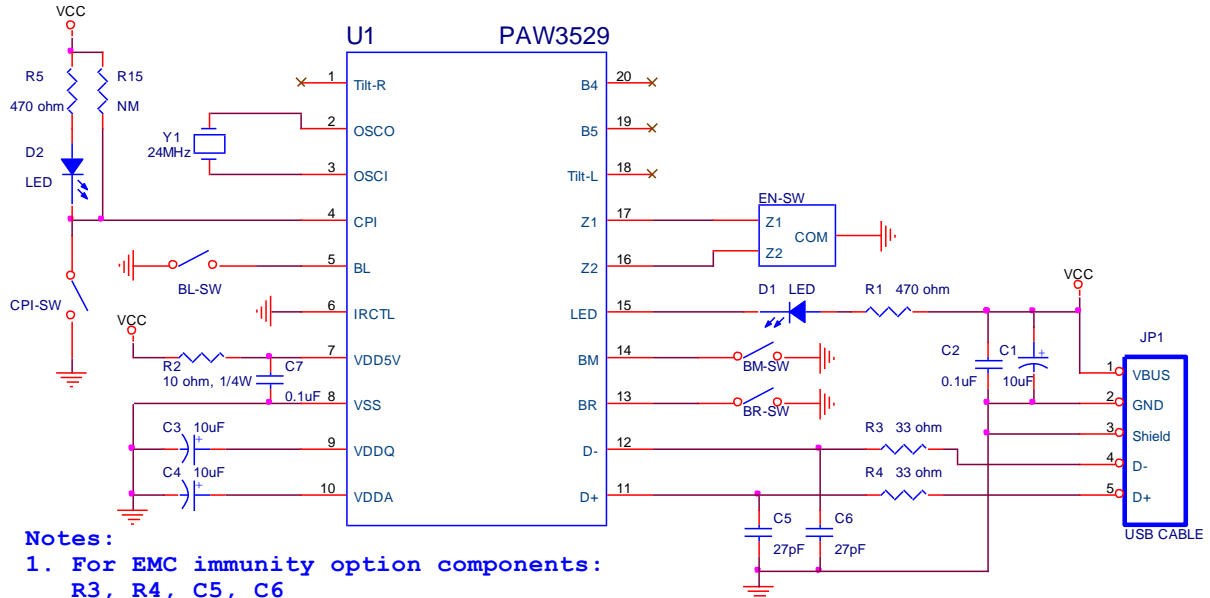

Notes:

1. For EMC immunity option components: R3, R4, C5, C6
2. Connector JP1 is suggested to has the pin sequence like: VBUS, GND, Shield, D-, D+

Figure 10. 3D3B Application Circuit with Mechanical Zwheel.

Mouse SoC (3D3B, IRPTR)

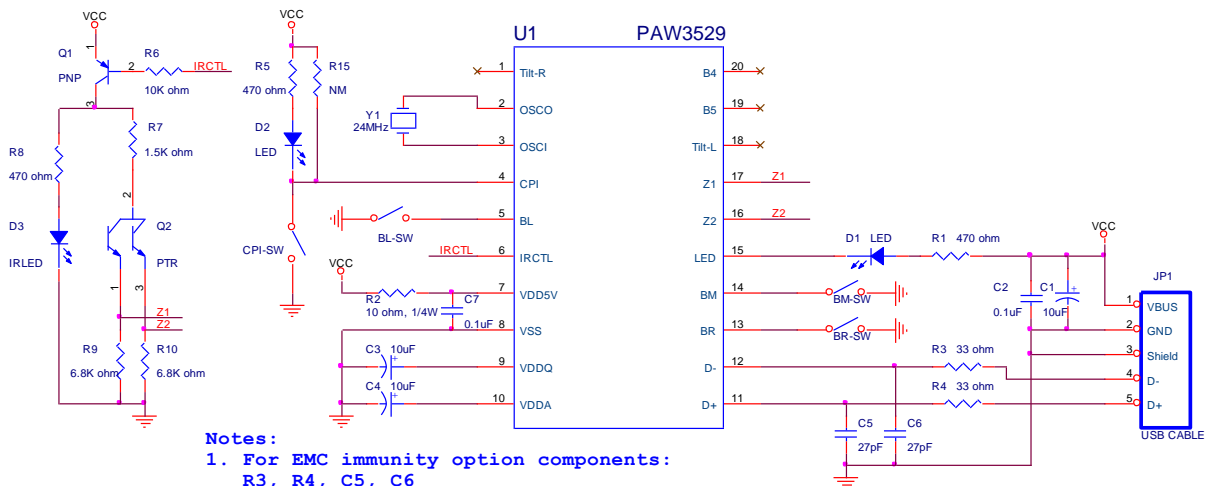

Notes:

1. For EMC immunity option components: R3, R4, C5, C6
2. Connector JP1 is suggested to has the pin sequence like: VBUS, GND, Shield, D-, D+

Figure 11. 3D3B Application Circuit with IRPTR Zwheel.



Mouse SoC (4D5B, Mechanical)

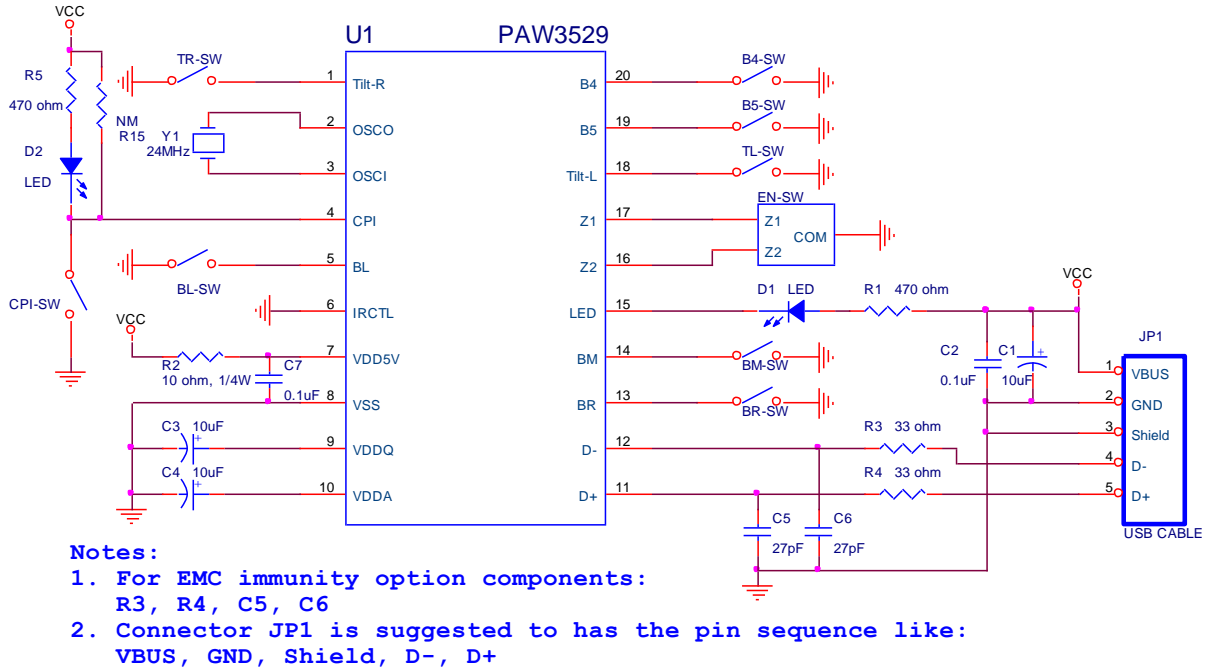

Figure 12. 4D5B Application Circuit with Mechanical Zwheel.

Mouse SoC (4D5B, IRPTR)

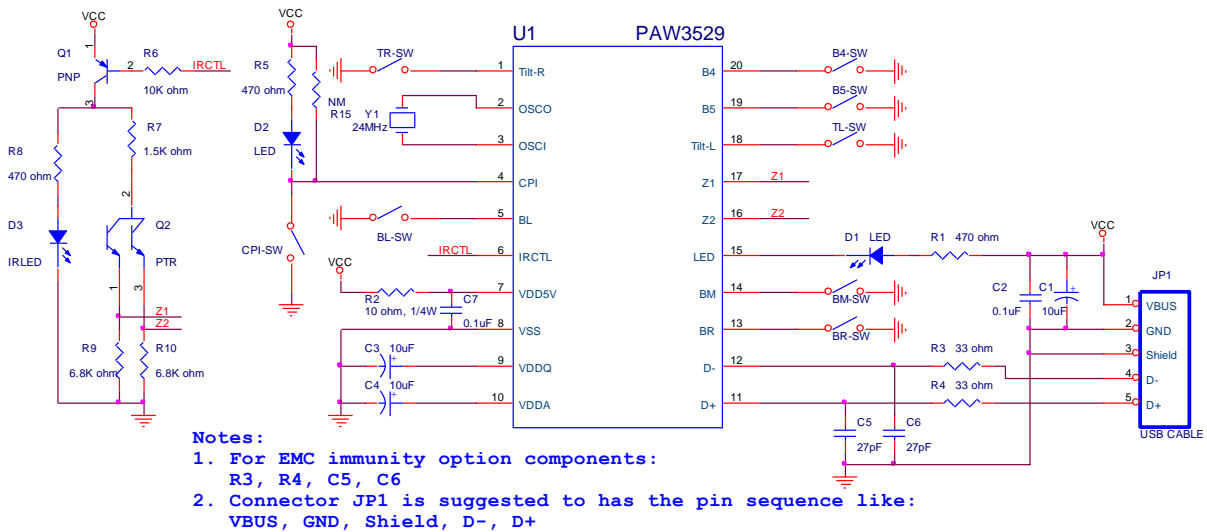

Figure 13. 4D5B Application Circuit with IRPTR Zwheel.

## 6.2 PCB Layout Guideline

The following guidelines apply to component placement and routing on the PCB. That will get an optimum EMC solution and tracking performance.

### 6.2.1 Key Components Placement Rules

1. Place resonator Y1 near SENSOR's pin2 and pin 3.
2. Place bulk capacitor C1 and bypass C2 near the USB CABLE.
3. Place C3 and C4 near SENSOR's pin9 and pin10.
4. The C5/C6 and R3/R4 should be placed as close to the USB CABLE.

### 6.2.2 Routing Rules

1. Caps for pins VDD5V, VDDQ, VDDA trace length must be less than 5 mm.
2. The trace length of OSCOUT, OSCIN must be less than 10 mm.

## 6.3 Recommended Value for R1

Radiometric intensity of LED

Bin limits (mW/Sr at 20mA)

LED Bin Grade	Min	Typ	Max	Unit
Q	21.2	-	25.4	mW/Sr

Note: Tolerance for each bin will be  $\pm 15\%$

R1 value (ohm),  $V_{DD} = 5.0V$

LED Bin Grade	Min	Typ	Max	Unit
Q	470	-	750	ohm

6.4. Optical Criterion

6.4.1 Recommended Red LED Angle Criterion

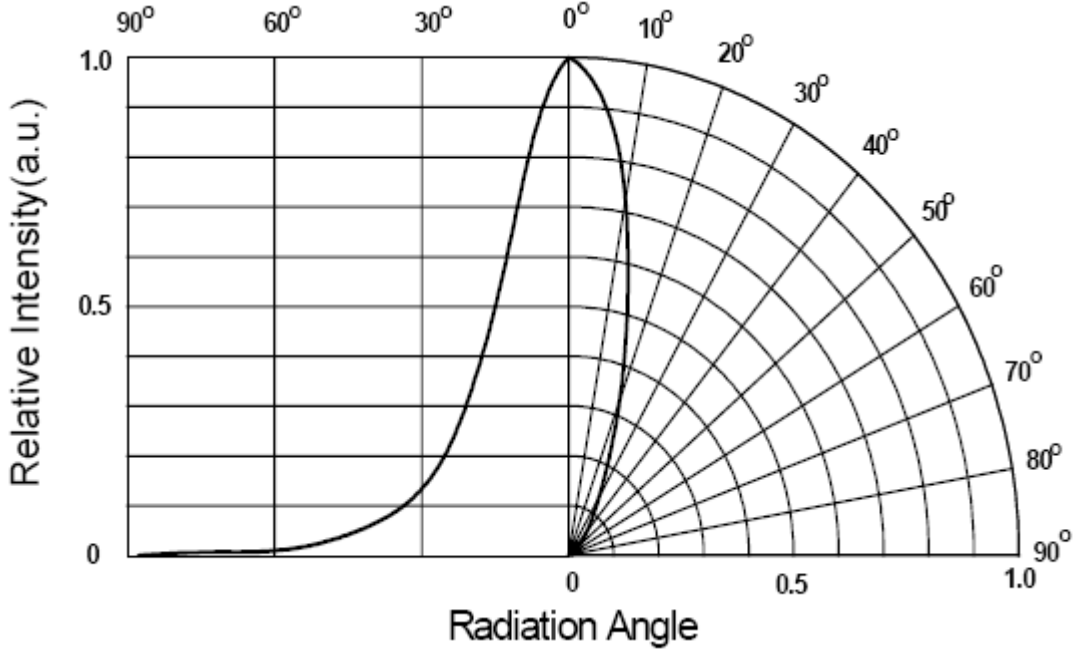

Figure 14. Radiation Characteristics

LED Viewing Angle	Min.	Typ.	Max.
$2\theta_{1/2}$	24	30	36

- Recommended using Chang-Yu LED goniophotometer V110 to measure the LED viewing angle.

6.4.2 Recommended Value for Optical Power

- In order to tracking performance of PAW3529-TXWA are acceptable and lower power consumption of LED, PixArt recommended value for optical power. By selecting LED bin grade or changing R1 value, optical power can be adjust. Optical power is measured from base plate rectangle hole, and LED is in DC mode. (Please see optical power measurement method AP note). Recommended using ADCMT power meter 8230E to measure the optical power.

Parameter	Min.	Typ.	Max.	Unit
Optical Power	250	-	400	uW

6.4 Resonator Suggestion

The following figure shows chip internal resonator circuit, and the table shows its internal parameters. PixArt strongly recommends the user using resonators which can work properly by 1.8V.

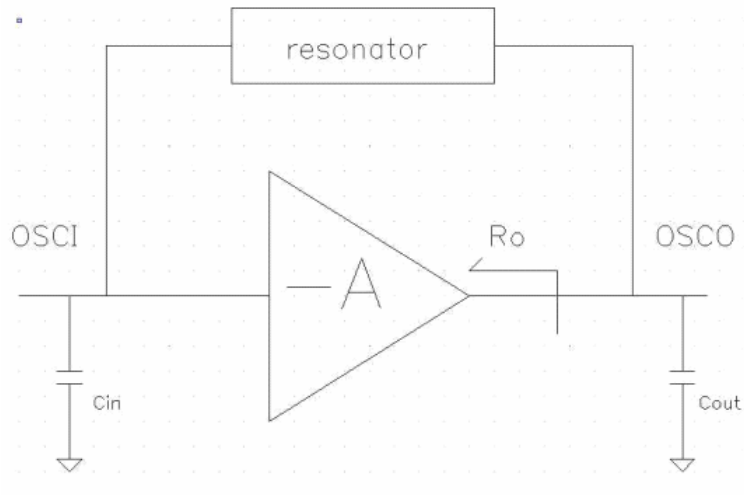

Figure 15. Application Circuit for PAW3529DH-TXWA

Internal Parameters	
I/O Voltage	3.3V
Cin	12.5pF ~ 15pF
Cout	12.5pF ~ 15pF
Impedance	966K ~ 1.78M ohm
Accuracy	24MHz +/- 1.5%

7. Package Information

7.1 Package Outline Drawing

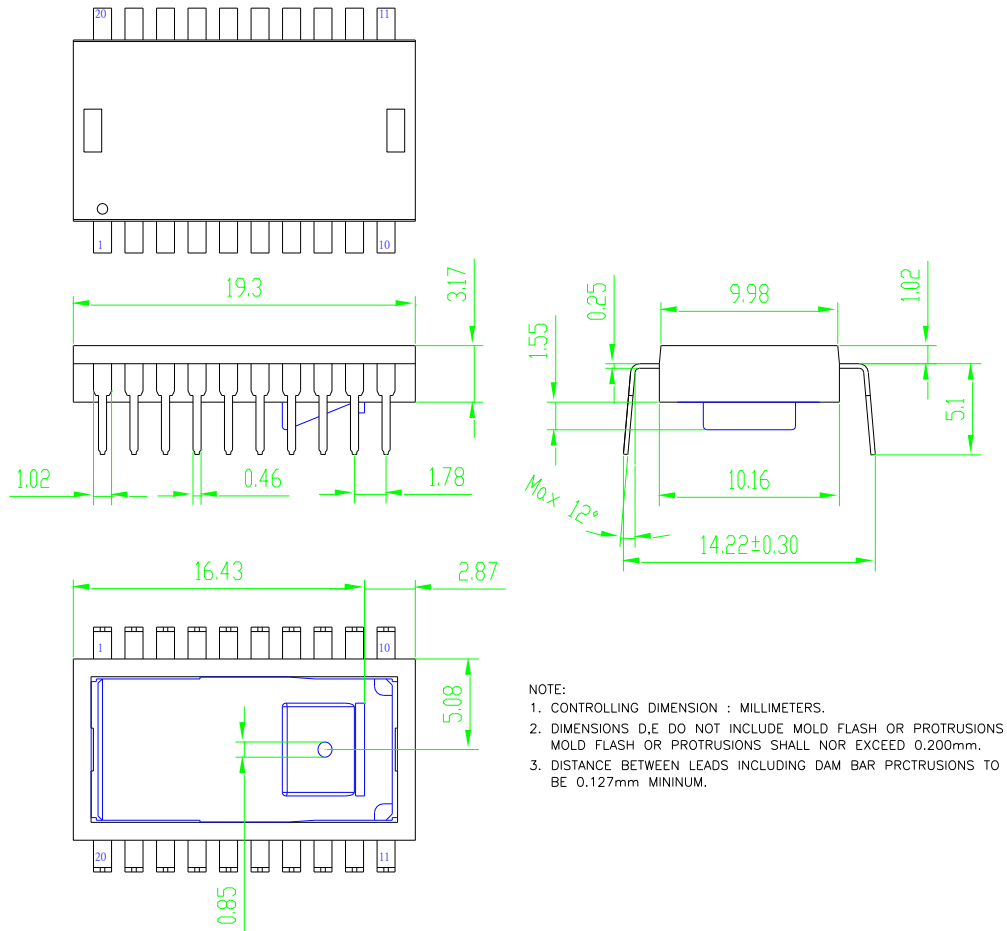

Figure 16. Package Outline Drawing

7.2 Recommended PCB Mechanical Cutouts and Spacing

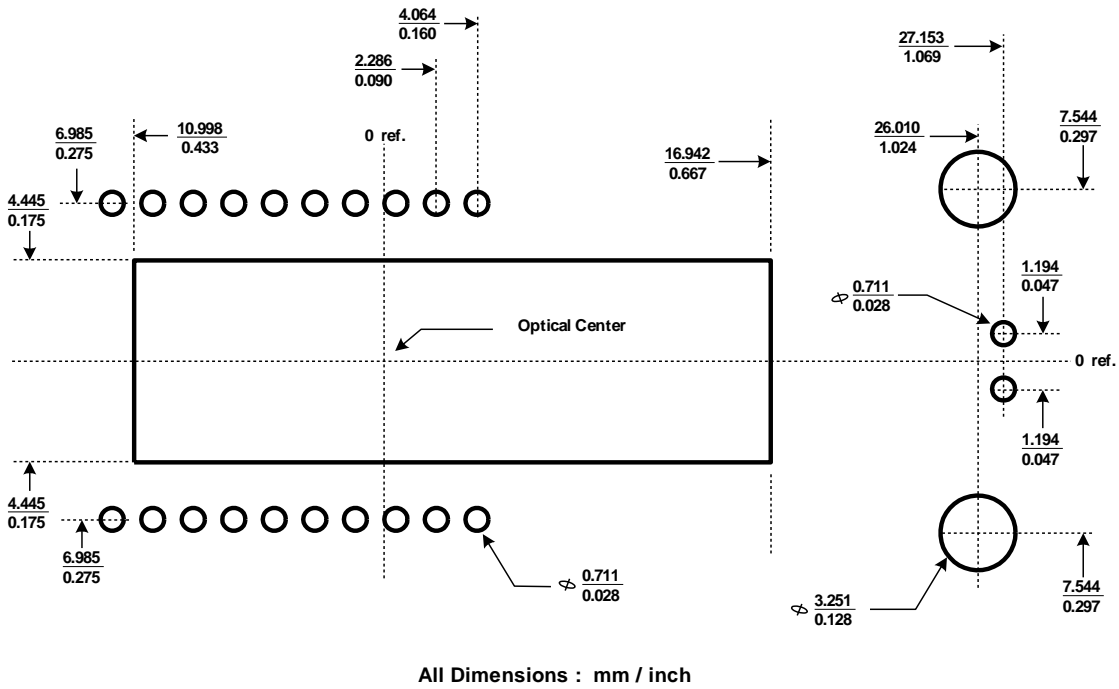

Figure 17. Recommended PCB Mechanical Cutouts and Spacing

**8. Update History**

Version	Update	Date
V1.0	Creation, Preliminary 1 <sup>st</sup> version	05/04/2010
V1.1	Modified lens mechanical dimension from 4.67mm to 4.62mm in page 25	07/22/2010
V1.2	Ch6.1 Application Circuit revised: R15 change to NM (No Mount) For datecode xxxxxx36xx, xxxxxx37xx	09/01/2010

Note: The Part No. of the Mouse Product with Prefix "PAN" shall NOT be made, sold, offered to sell, imported or used in or into USA, Canada, Japan and EU. For "PAN", PixArt has only gained territory-limited patent license from Avago. Avago reserve right to take legal action against our customers who fails to comply the above term. PLEASE NOTE THAT PixArt will NOT defend, indemnify, or provide any assistance to our customers who fail to comply the term. IF YOU DO NOT AGREE THE TERM, PIXART WILL NOT DELIVER "PAN" PRODUCTS TO YOU.