

POWERTIP TECH. CORP.

DISPLAY DEVICES FOR BETTER ELECTRONIC DESIGN

Specification For Approval

Customer : _____

Model Type : LCD Module

Sample Code : PC0802ARS-AWA-A-SA

Mass Production Code : _____

Edition : A

Customer Sign	Sales Sign	Approved By	Prepared By

CONTENTS

1.SPECIFICATIONS

- 1.1 Features
- 1.2 Mechanical Specifications
- 1.3 Absolute Maximum Ratings
- 1.4 DC Electrical Characteristics
- 1.5 Optical Characteristics

2.MODULE STRUCTURE

- 2.1 Counter Drawing
- 2.2 Interface Pin Description
- 2.3 Timing Characteristics
- 2.4 Display Command
- 2.5 Character Pattern



POWERTIP TECHNOLOGY CORPORATION

DISPLAY DEVICES FOR BETTER ELECTRONIC DESIGN

1. SPECIFICATIONS

1.1 Features

- 8-characters, two-lines liquid crystal display of 5*8 dot matrix + cursor
- 1/16 Duty, 1/4 bias
- STN LCD, positive, gray
- Reflective LCD
- 6 o'clock viewing angle
- 8 bits parallel data input

1.2 Mechanical Specifications

- Outline dimension : 58.0mm(L)* 32.0mm(W)* 14.0mm max.(H)
- Viewing area : 38.0mm *16.0mm
- Active area : 27.81mm *11.5mm
- Dot size : 0.56mm *0.66mm
- Dot pitch : 0.6mm *0.7mm
- Character Size : 2.96mm *5.56mm

1.3 Absolute Maximum Ratings

Item	Symbol	Conditions	Min.	Max.	Unit
Power supply Voltage	VDD	-	-0.3	7.0	V
LCD drive Supply voltage	VDD-VO	-	-0.3	13.0	V
Input voltage	VIN	-	-0.3	V _{DD} +0.3	V
Operating temperature	TOPR	-	0	50	°C
Storage temperature	TSTG	-	-20	70	°C
Humidity	HD	-	-	90	%RH

1.4 DC Electrical Characteristics

VDD=+5V±10%, VSS=0V, TA=25°C

Item	Symbol	Condition	Min.	Typ.	Max.	Unit
Logic Supply voltage	VDD	-	4.5	-	5.5	V
“H” input voltage	V _{IH}	-	2.2	-	V _{DD}	V
“L” input voltage	V _{IL}	-	-0.3	-	0.6	V
“H” output voltage	V _{OH}	-	2.4	-	V _{DD}	V
“L” output voltage	V _{OL}	-	-	-	0.4	V
Supply current	I _{DD}	VDD=5V	-	1.34	1.38	mA
LCD driving voltage	VOP	VDD-VO	3.87	-	4.97	V



POWERTIP TECHNOLOGY CORPORATION

DISPLAY DEVICES FOR BETTER ELECTRONIC DESIGN

1.5 Optical Characteristics

1/16 duty, 1/4 bias, $V_{OPR}=4.5V$, $T_a=25^{\circ}C$

Item	Symbol	Conditions	Min.	Typ.	Max	Reference
Viewing angle	θ	$C \geq 2.0, \varnothing = 0^{\circ}$	-30°	-	30°	Notes 1 & 2
Contrast	C	$\theta = 5^{\circ}, \varnothing = 0^{\circ}$	-	3	-	Note 3
Response time(rise)	t_r	$\theta = 5^{\circ}, \varnothing = 0^{\circ}$	-	100 ms	150 ms	Note 4
Response time(fall)	t_f	$\theta = 5^{\circ}, \varnothing = 0^{\circ}$	-	300 ms	500 ms	Note 4

Parameter	Symbol	Temperature ($^{\circ}C$)	Standard			Unit
			Min	Typ	Max	
Driving voltage	V_{OP}	0	4.6	4.9	5.2	V
		25	4.2	4.5	4.8	
		50	3.9	4.2	4.5	



POWERTIP TECHNOLOGY CORPORATION

DISPLAY DEVICES FOR BETTER ELECTRONIC DESIGN

Note 1: Definition of angles θ and \varnothing

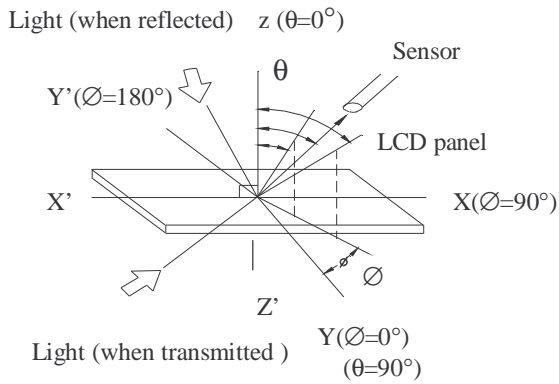

Note 2: Definition of viewing angles θ_1 and θ_2

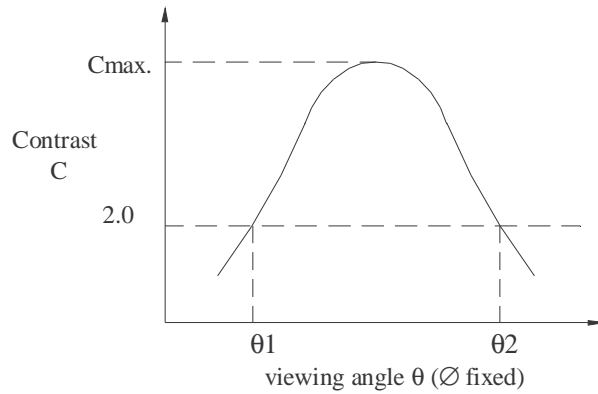

Note : Optimum viewing angle with the naked eye and viewing angle θ at C_{max} . Above are not always the same

Note 3: Definition of contrast C

$$C = \frac{\text{Brightness (reflection) of unselected dot (B2)}}{\text{Brightness (reflection) of selected dot (B1)}}$$

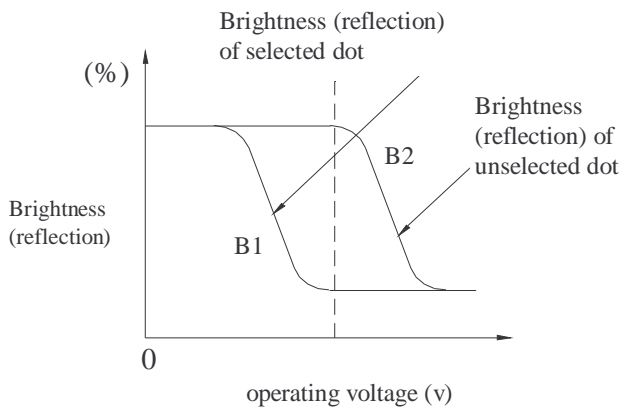

Note 4: Definition of response time

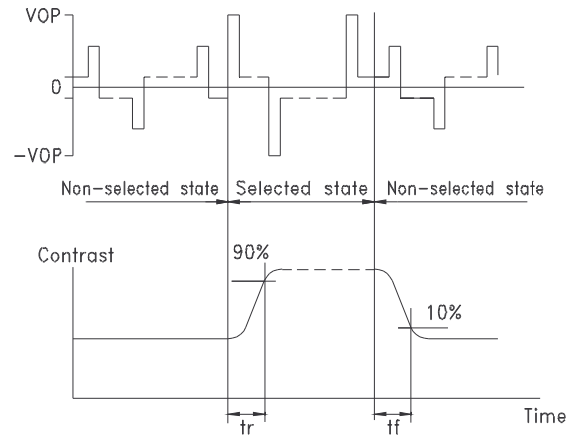

Note: Measured with a transmissive LCD panel which is displayed 1 cm^2

V_{OPR} : Operating voltage
 t_r : Response time (rise)

f_{FRM} : Frame frequency
 t_f : Response time (fall)



POWERTIP TECHNOLOGY CORPORATION

DISPLAY DEVICES FOR BETTER ELECTRONIC DESIGN

2. MODULE STRUCTURE

2.1 Counter Drawing

*See Appendix 1

2.2 Interface Pin Description

Pin No.	Symbol	Signal Description
1	VSS	Power Supply ($V_{SS}=0$)
2	VDD	Power Supply ($V_{DD}>V_{SS}$)
3	VO	Operating voltage (LCD Driver)
4	RS	Register Selection input High = Data register Low = Instruction register (for write) Busy flag address counter (for read)
5	$\overline{\text{R/W}}$	Read/Write signal input is used to select the read/write mode High = Read mode, Low = Write mode
6	E	Start enable signal to read or write the data
7~10	DB0 ~ DB3	Four low order bi-directional three-state data bus lines. Use for data transfer between the MPU and the LCD module. These four are not used during 4-bit operation.
11~14	DB4 ~ DB7	Four high order bi-directional three-state data bus lines. Used for data transfer between the MPU and the LCD module. DB7 can be used as a busy flag.

Contrast Adjust

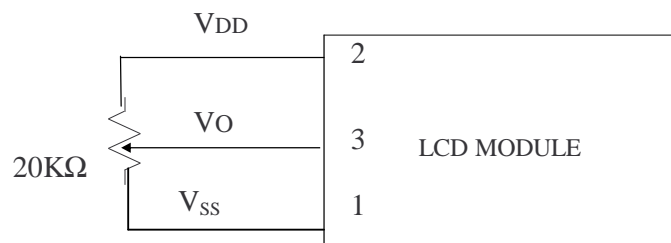

POWERTIP TECHNOLOGY CORPORATION

DISPLAY DEVICES FOR BETTER ELECTRONIC DESIGN

2.3 Timing Characteristics

- Read cycle

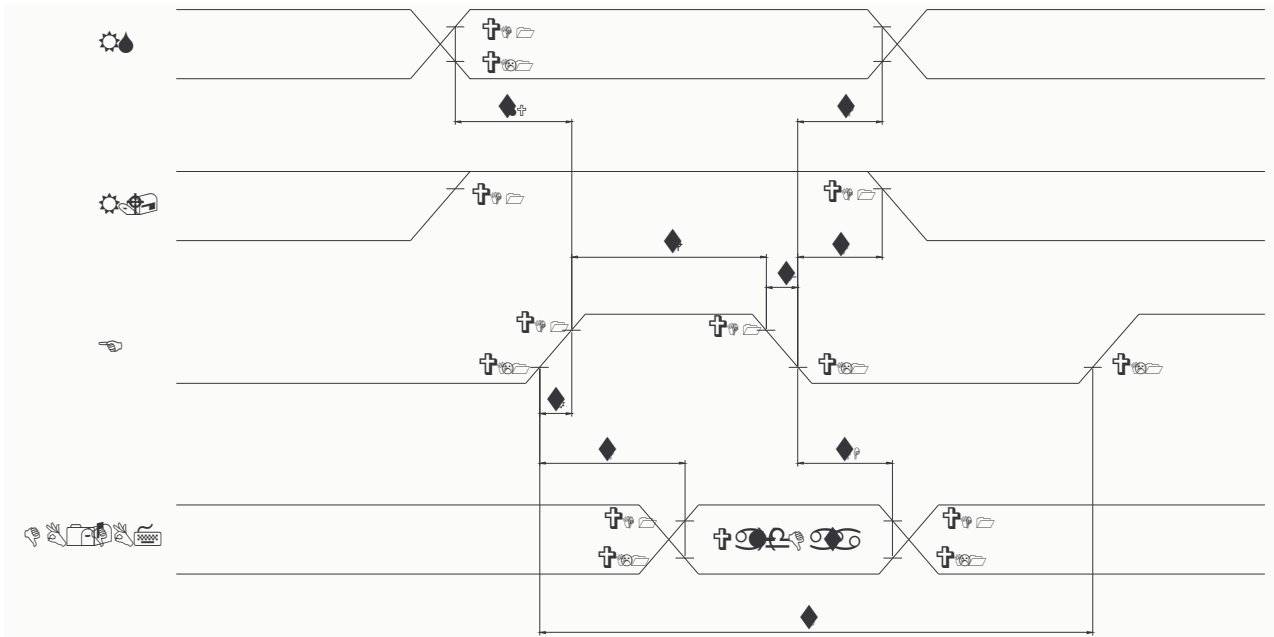

- Write cycle

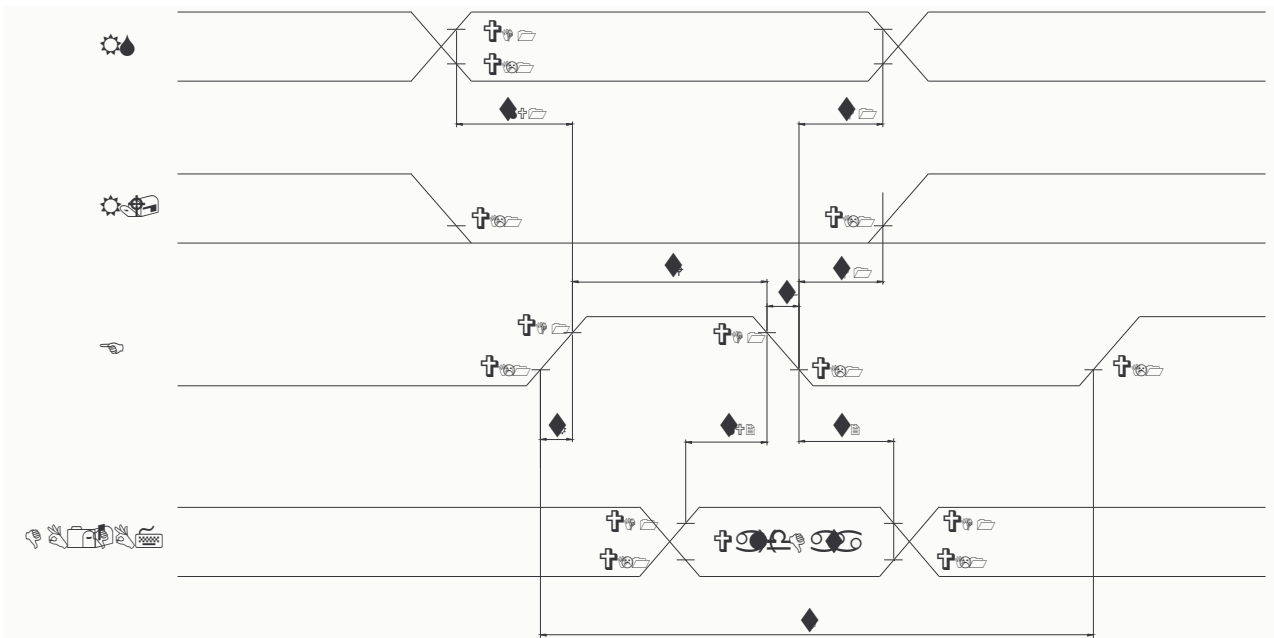

POWERTIP TECHNOLOGY CORPORATION

DISPLAY DEVICES FOR BETTER ELECTRONIC DESIGN

• Read cycle

VDD=4.5V~5.5V, Ta=-30~+85°C

Characteristics	Symbol	Min.	Typ.	Max.	Unit
E Cycle Time	t_C	500	-	-	ns
E Rise / Fall Time	t_R, t_F	-	-	20	ns
E Pulse Width (High, Low)	t_W	230	-	-	ns
R/W and RS Setup Time	t_{SU}	40	-	-	ns
R/W and RS Hold Time	t_H	10	-	-	ns
Data Output Delay Time	t_D	-	-	120	ns
Data Hold Time	t_{DH}	5	-	-	ns

• Write cycle

Characteristics	Symbol	Min.	Typ.	Max.	Unit
E Cycle Time	t_C	500	-	-	ns
E Rise / Fall Time	t_R, t_F	-	-	20	ns
E Pulse Width (High, Low)	t_W	230	-	-	ns
R/W and RS Setup Time	t_{SU1}	40	-	-	ns
R/W and RS Hold Time	t_{H1}	10	-	-	ns
Data Setup Time	t_{SU2}	80	-	-	ns
Data Hold Time	t_{H2}	10	-	-	ns

**POWERTIP TECHNOLOGY CORPORATION**

DISPLAY DEVICES FOR BETTER ELECTRONIC DESIGN

2.4 Display Command

Instructions	Instruction Code										Description	Execution Time (fosc = 270KHZ)	
	RS	R/W	DB7	DB6	DB5	DB4	DB3	DB2	DB1	DB0			
Clear Display	0	0	0	0	0	0	0	0	0	0	1	Write "20H" to DDRAM. and set DDRAM address to "00H" from AC.	1.52ms
Return Home	0	0	0	0	0	0	0	0	0	1	×	Set DDRAM address to "00H" from AC and return cursor to it's original position if shifted. The contents of DDRAM are not changed.	1.52ms
Entry Mode Set	0	0	0	0	0	0	0	1	I/D	SH		Assign cursor moving direction and make shift of entire display enable.	37μs
Display ON/OFF Control	0	0	0	0	0	0	1	D	C	B		Sets display (D), cursor(C), and blinking of cursor(B) on/off control bit.	37μs
Cursor or Display Shift	0	0	0	0	0	1	S/C	R/L	×	×		Set cursor moving and display shift control bit, and the direction, without changing of DDRAM data.	37μs
Function Set	0	0	0	0	1	DL	N	F	×	×		Set interface data length (DL:4-bit/8-bit), numbers of display line (N: 1-line/2-line), display font type(F:5*8 dots/5*11 dots)	37μs
Set CGRAM Address	0	0	0	1	AC5	AC4	AC3	AC2	AC1	AC0		Set CGRAM address in address counter.	37μs
Set DDRAM Address	0	0	1	AC6	AC5	AC4	AC3	AC2	AC1	AC0		Set DDRAM address in address counter.	37μs
Read Busy Flag and Address	0	1	BF	AC6	AC5	AC4	AC3	AC2	AC1	AC0		Whether during internal operation or not can be known by reading BF. The contents of address counter can also be read.	0μs
Write Data to RAM	1	0	D7	D6	D5	D4	D3	D2	D1	D0		Write data into internal RAM (DDRAM/CGRAM).	43μs
Read Data from RAM	1	1	D7	D6	D5	D4	D3	D2	D1	D0		Read data from internal RAM (DDRAM/CGRAM).	43μs

※ "×": don't

care



POWERTIP TECHNOLOGY CORPORATION

DISPLAY DEVICES FOR BETTER ELECTRONIC DESIGN

2.5 Character Pattern



POWERTIP TECHNOLOGY CORPORATION

DISPLAY DEVICES FOR BETTER ELECTRONIC DESIGN