

POWERTIP TECH. CORP.

DISPLAY DEVICES FOR BETTER ELECTRONIC DESIGN

Specification For Approval

Customer : _____
Model Type : LCD MODULE
Sample Code : _____
Mass Production Code : PC1601ARU-ASO-A
Edition : 0

Customer Sign	Sales Sign	Checked By (QA)	Approved By	Prepared By
			<i>awell</i> 2/17 <i>Tom</i> 2/18	<i>ASO</i> 2/17

Revision Record

Date(y/m/d)	Rev.	Description	Note	Page
2003/2/9	0	Revised Contents		

Total Page : 1 ~ 19



POWERTIP TECHNOLOGY CORPORATION

DISPLAY DEVICES FOR BETTER ELECTRONIC DESIGN

Contents

1. SPECIFICATIONS

- 1.1 Features
- 1.2 Mechanical Specifications
- 1.3 Absolute Maximum Ratings
- 1.4 DC Electrical Characteristics
- 1.5 Optical Characteristics

2. MODULE STRUCTURE

- 2.1 Counter Drawing
- 2.2 Interface Pin Description
- 2.3 Timing Characteristics
- 2.4 Display Command

3. QUALITY ASSURANCE SYSTEM

- 3.1 Quality Assurance Flow Chart
- 3.2 Inspection Specification

4. RELIABILITY TEST

- 4.1 Reliability Test Condition

5. PRECAUTION RELATING PRODUCT HANDLING

- 5.1 Safety
- 5.2 Handling
- 5.3 Storage
- 5.4 Terms of Warranty



1. SPECIFICATIONS

1.1 Features

Item	Standard Value
Display Type	16 * 1 Characters
LCD Type	STN, YG, Reflective, Positive, Normal Temp.
Driver Type	1/16 Duty , 1/4Bias
Viewing Direction	6 O' clock
Backlight	-
Weight	-
Other	-

1.2 Mechanical Specifications

Item	Standard Value	Unit
Outline Dimension	80.0 (L)* 36.0 (W)*9.7max.(H)	mm
Viewing Area	64.5 (L)*13.8 (W)	mm
Active Area	59.62 (L)* 6.56 (W)	mm
Dot Size	0.55 (L) * 0.75 (w)	mm
Dot Pitch	0.63 (L) * 0.83 (w)	mm
Character Size	3.07 (L) *6.56 (W)	mm

1.3 Absolute Maximum Ratings

Item	Symbol	Conditions	Min.	Max.	Unit
Power supply Voltage	V_{DD}	-	-0.3	7.0	V
LCD drive Supply voltage	$V_{DD}-V_O$	-	$V_{DD}-15.0$	$V_{DD}+0.3$	V
Input voltage	V_{IN}	-	-0.3	$V_{DD}+0.3$	V
Operating temperature	T_{OPR}	-	0	50	°C
Storage temperature	T_{STG}	-	-20	70	°C
Humidity	HD	-	-	90	%RH



POWERTIP TECHNOLOGY CORPORATION

DISPLAY DEVICES FOR BETTER ELECTRONIC DESIGN

1.4 DC Electrical Characteristics

$V_{DD}=+5V\pm 10\%$, $V_{SS}=0V$, $T_A=25^\circ C$

Item	Symbol	Condition	Min.	Typ.	Max.	Unit
Logic Supply voltage	V_{DD}	-	4.5	5	5.5	V
“H” input voltage	V_{IH}	-	2.2	-	V_{DD}	V
“L” input voltage	V_{IL}	-	-0.3	-	0.6	V
“H” output voltage	V_{OH}	$I_{OH}=-0.205mA$	2.4	-	V_{DD}	V
“L” output voltage	V_{OL}	$I_{OL}=1.2mA$	-	-	0.4	V
Supply current	I_{DD}	$V_{DD}=5V$	-	1.5	2.5	mA
LCD driving voltage	V_{OP}	$V_{DD}-V_O(0^\circ)$	-	-	-	V
		$V_{DD}-V_O(25^\circ)$	4.3	4.5	4.7	
		$V_{DD}-V_O(50^\circ)$	-	-	-	

1.5 Optical Characteristics

1/16 duty, 1/4 bias, $V_{OP}=4.5V$, $T_A=25^\circ C$

Item	Symbol	Conditions	Min.	Typ.	Max	Reference
Viewing angle	θ	$C \geq 2.0, \phi = 0^\circ$	45°	-	-	Notes 1 & 2
Contrast	CR	$\theta = 25^\circ$	3	5	-	Note 3
Response time(rise)	T_r	$\phi = 0^\circ$ $\theta = 25^\circ$	-	180ms	-	Note 4
Response time(fall)	T_f	$\phi = 0^\circ$ $\theta = 25^\circ$	-	300ms	-	



POWERTIP TECHNOLOGY CORPORATION

DISPLAY DEVICES FOR BETTER ELECTRONIC DESIGN

Note 1: Definition of angles θ and ϕ

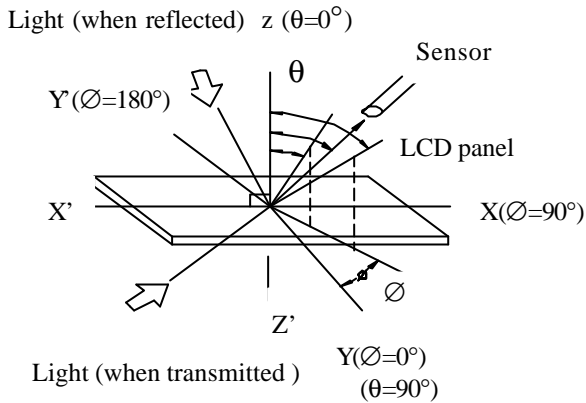

Note 2: Definition of viewing angles θ_1 and θ_2

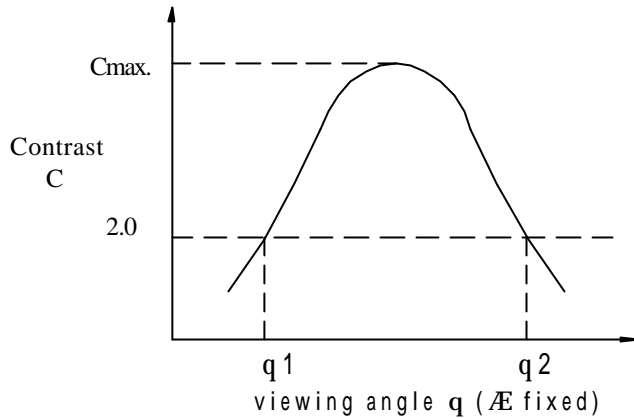

Note : Optimum viewing angle with the naked eye and viewing angle q at C_{max} . Above are not always the same

Note 3: Definition of contrast C

$$C = \frac{\text{Brightness (reflection) of unselected dot (B2)}}{\text{Brightness (reflection) of selected dot (B1)}}$$

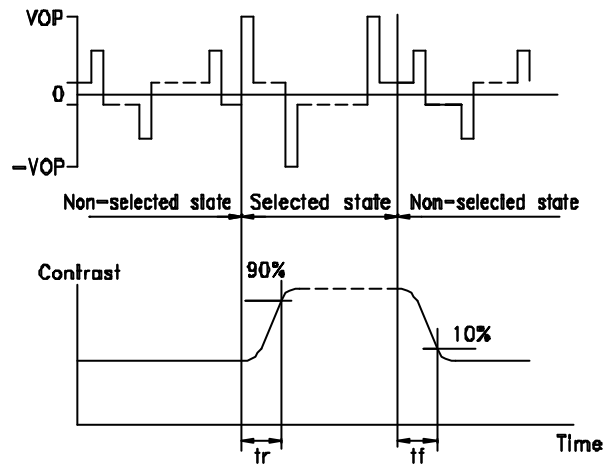
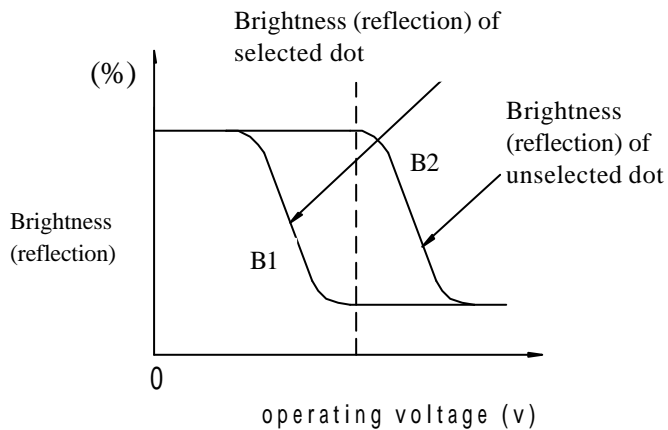

Note: Measured with a transmissive LCD panel which is displayed 1 cm^2

V_{OPR} : Operating voltage f_{FRM} : Frame frequency
 t_r : Response time (rise) t_f : Response time (fall)



POWERTIP TECHNOLOGY CORPORATION

DISPLAY DEVICES FOR BETTER ELECTRONIC DESIGN

2. MODULE STRUCTURE

2.1 Counter Drawing

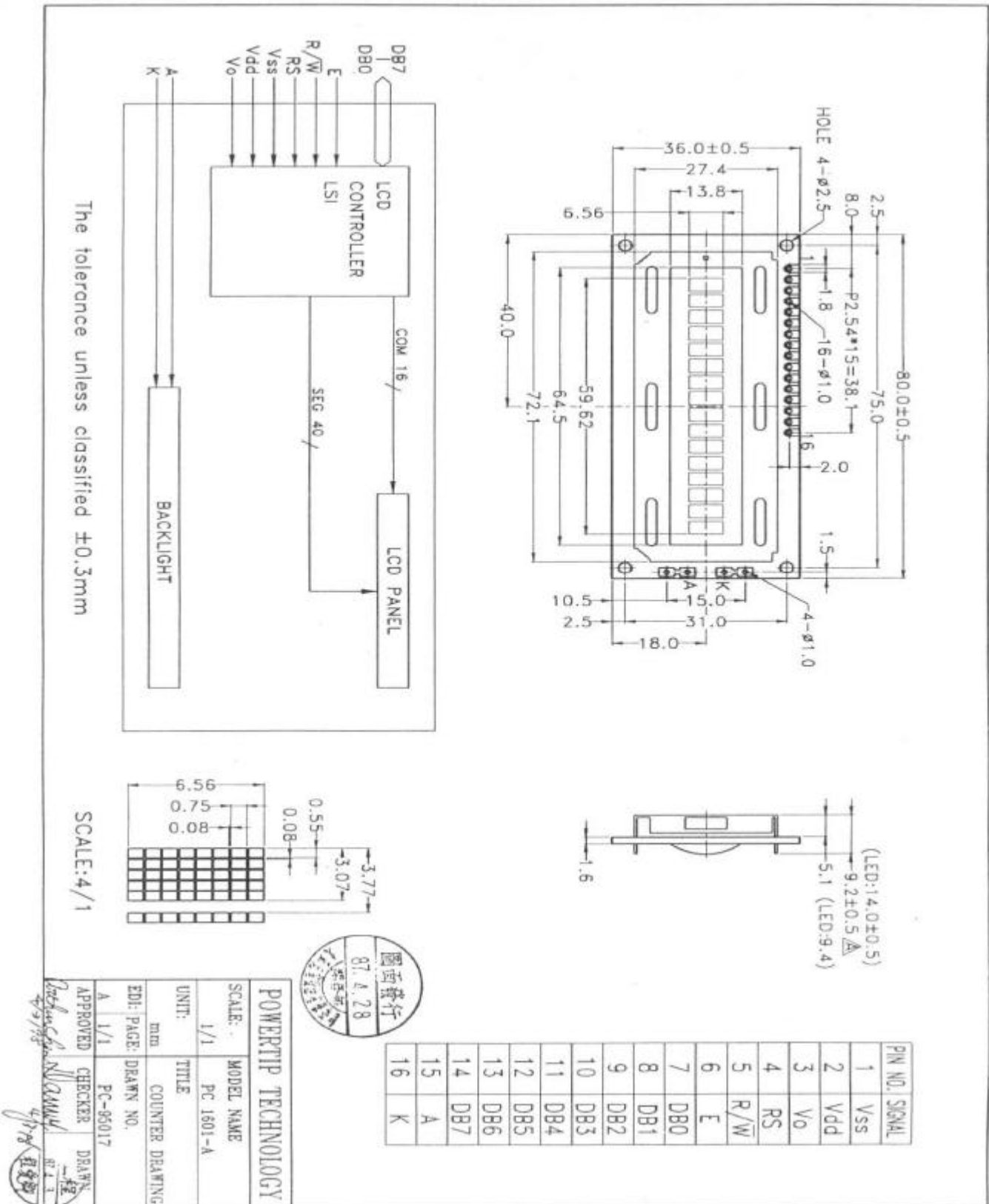

POWERTIP TECHNOLOGY CORPORATION

DISPLAY DEVICES FOR BETTER ELECTRONIC DESIGN

2.2 Interface Pin Description

Pin No.	Symbol	Signal Description
1	VSS	Power Supply ($V_{SS}=0$)
2	VDD	Power Supply ($V_{DD}>V_{SS}$)
3	Vo	Operating voltage for LCD (variable)
4	RS	Register Selection input High = Data register Low = Instruction register (for write) Busy flag address counter (for read)
5	$\overline{R/W}$	Read/Write signal input is used to select the read/write mode High = Read mode, Low = Write mode
6	E	Start enable signal to read or write the data
7~10	DB0 ~ DB3	Four low order bi-directional three-state data bus lines. Used for data transfer between the MPU and the LCD module. These four are not used during 4-bit operation.
11~14	DB4~DB7	Four high order bi-directional three-state data bus lines. Used for data transfer between the MPU and the LCD module. DB7 can be used as a busy flag.
15	A	NC
16	K	NC

Contrast Adjust

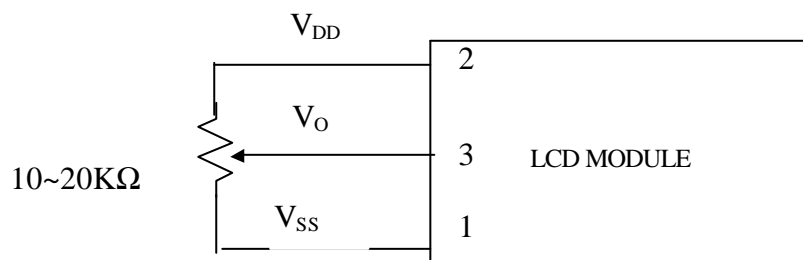

POWERTIP TECHNOLOGY CORPORATION

DISPLAY DEVICES FOR BETTER ELECTRONIC DESIGN

2.3 Timing Characteristics

· Read cycle

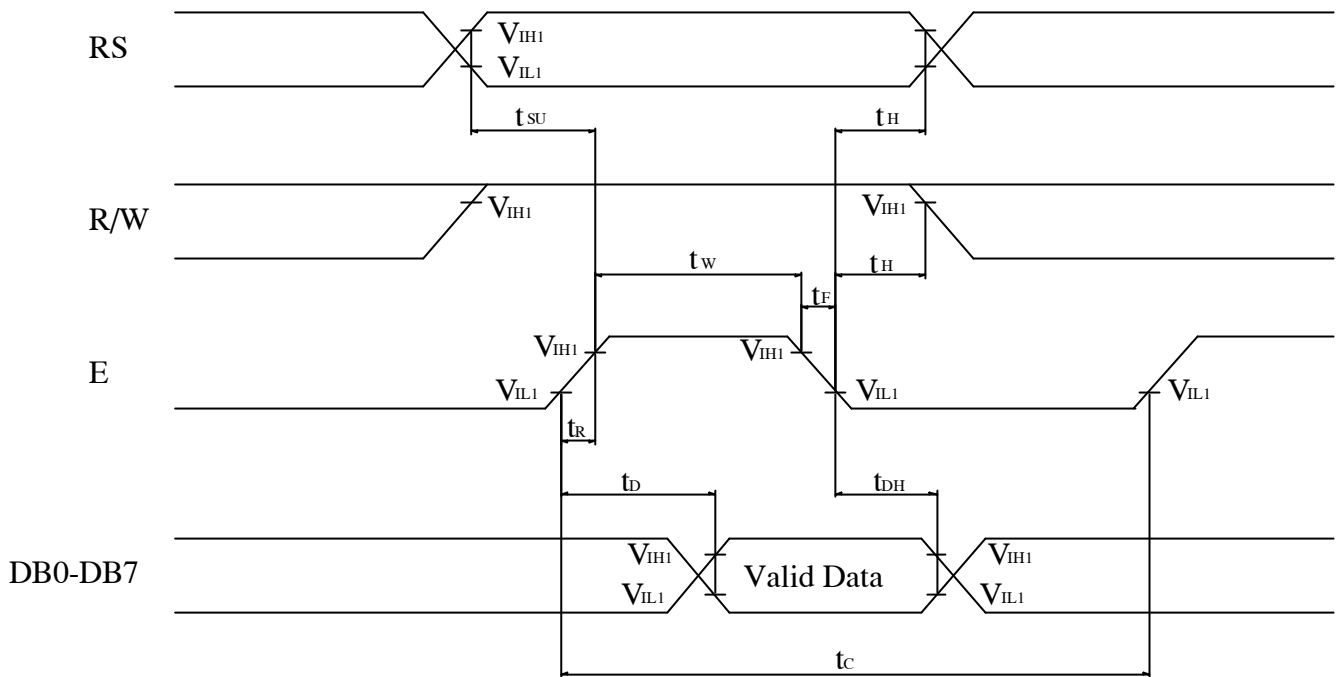

· Write cycle

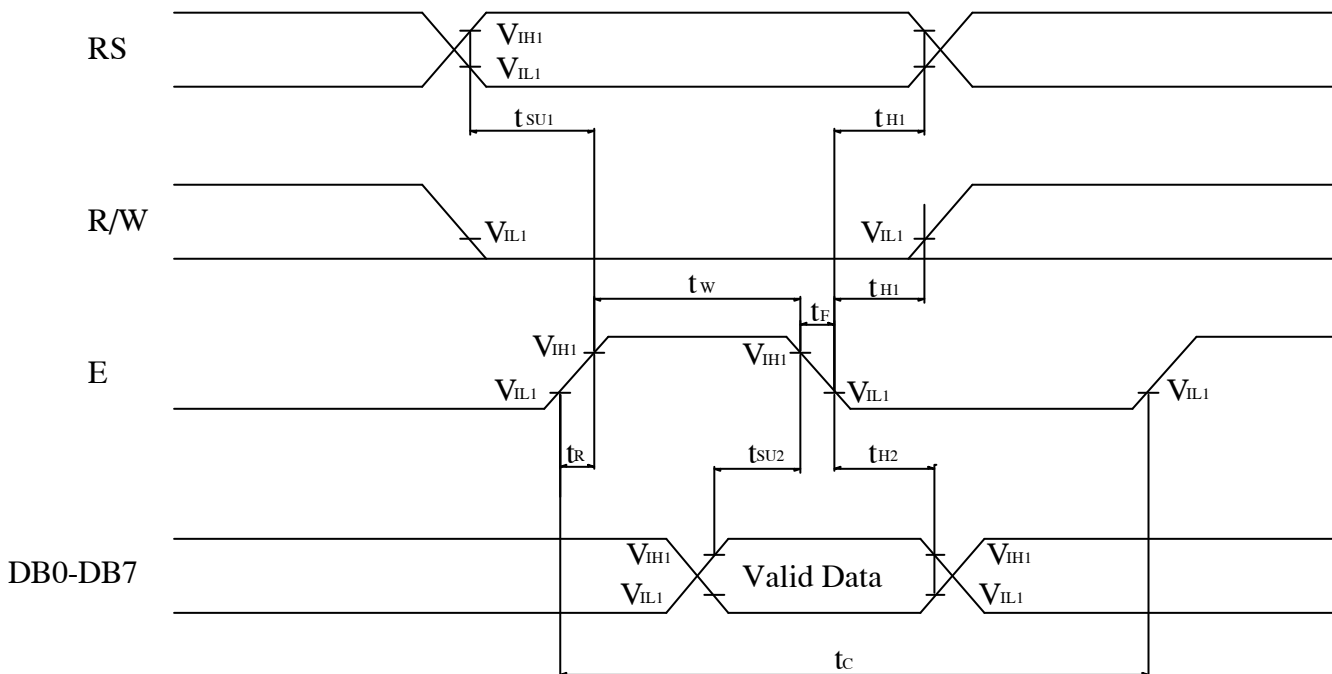

POWERTIP TECHNOLOGY CORPORATION

DISPLAY DEVICES FOR BETTER ELECTRONIC DESIGN

- Read cycle

VDD=4.5V~5.5V, Ta=25

Characteristics	Symbol	Min.	Typ.	Max.	Unit
E Cycle Time	t_C	500	-	-	ns
E Rise / Fall Time	t_R, t_F	-	-	20	ns
E Pulse Width (High, Low)	t_W	230	-	-	ns
R/W and RS Setup Time	t_{SU}	40	-	-	ns
R/W and RS Hold Time	t_H	10	-	-	ns
Data Output Delay Time	t_D	-	-	120	ns
Data Hold Time	t_{DH}	5	-	-	ns

- Write cycle

Characteristics	Symbol	Min.	Typ.	Max.	Unit
E Cycle Time	t_C	500	-	-	ns
E Rise / Fall Time	t_R, t_F	-	-	20	ns
E Pulse Width (High, Low)	t_W	230	-	-	ns
R/W and RS Setup Time	t_{SU1}	40	-	-	ns
R/W and RS Hold Time	t_{H1}	10	-	-	ns
Data Setup Time	t_{SU2}	80	-	-	ns
Data Hold Time	t_{H2}	10	-	-	ns



POWERTIP TECHNOLOGY CORPORATION

DISPLAY DEVICES FOR BETTER ELECTRONIC DESIGN

2.4 Display Command

Instructions	Instruction Code										Description	Execution Time (fosc = 270KHZ)	
	RS	R/W	DB7	DB6	DB5	DB4	DB3	DB2	DB1	DB0			
Clear Display	0	0	0	0	0	0	0	0	0	0	1	Write "20H" to DDRAM. and set DDRAM address to "00H" from AC.	1.53ms
Return Home	0	0	0	0	0	0	0	0	0	1	×	Set DDRAM address to "00H" from AC and return cursor to it's original position if shifted. The contents of DDRAM are not changed.	1.53ms
Entry Mode Set	0	0	0	0	0	0	0	0	1	I/D	SH	Assign cursor moving direction and make shift of entire display enable.	39μs
Display ON/OFF Control	0	0	0	0	0	0	0	1	D	C	B	Sets display (D), cursor(C), and blinking of cursor(B) on/off control bit.	39μs
Cursor or Display Shift	0	0	0	0	0	0	1	S/C	R/L	×	×	Set cursor moving and display shift control bit, and the direction, without changing of DDRAM data.	39μs
Function Set	0	0	0	0	0	1	DL	N	F	×	×	Set interface data length (DL:4-bit/8-bit), numbers of display line (N: 1-line/2-line), display font type(F:5*8 dots/5*11 dots)	39μs
Set CGRAM Address	0	0	0	1	AC5	AC4	AC3	AC2	AC1	AC0		Set CGRAM address in address counter.	39μs
Set DDRAM Address	0	0	1	AC6	AC5	AC4	AC3	AC2	AC1	AC0		Set DDRAM address in address counter.	39μs
Read Busy Flag and Address	0	1	B F	AC6	AC5	AC4	AC3	AC2	AC1	AC0		Whether during internal operation or not can be known by reading BF. The contents of address counter can also be read.	0μs
Write Data to RAM	1	0	D 7	D6	D5	D4	D3	D2	D1	D0		Write data into internal RAM (DDRAM/CGRAM).	43μs
Read Data from RAM	1	1	D 7	D6	D5	D4	D3	D2	D1	D0		Read data from internal RAM (DDRAM/CGRAM).	43μs

" × ":don't care



POWERTIP TECHNOLOGY CORPORATION

DISPLAY DEVICES FOR BETTER ELECTRONIC DESIGN

2.5 Character Pattern

CHARACTER PATTERN(SO/HO/EA,WA)

Lower 4 Bits \ Upper 4 Bits	0000	0001	0010	0011	0100	0101	0110	0111	1000	1001	1010	1011	1100	1101	1110	1111
xxxx0000	CG RAM (1)			0	1	2	3	4				5	6	7	8	9
xxxx0001	(2)	!	1	A	0	a	4				6	7	8	9		
xxxx0010	(3)	"	2	B	R	b	r				7	8	9			
xxxx0011	(4)	#	3	C	S	c	s				8	9				
xxxx0100	(5)	\$	4	D	T	d	t				9					
xxxx0101	(6)	%	5	E	U	e	u									
xxxx0110	(7)	&	6	F	V	f	v									
xxxx0111	(8)	'	7	G	W	g	w									
xxxx1000	(1)	(8	H	X	h	x									
xxxx1001	(2))	9	I	Y	i	y									
xxxx1010	(3)	*	:	J	Z	j	z									
xxxx1011	(4)	+	;	K	[k	[
xxxx1100	(5)	,	<	L	#	l	l									
xxxx1101	(6)	-	=	M]	m]									
xxxx1110	(7)	.	>	N	^	n	^									
xxxx1111	(8)	/	?	_	~	o	~									



POWERTIP TECHNOLOGY CORPORATION

DISPLAY DEVICES FOR BETTER ELECTRONIC DESIGN

3. QUALITY ASSURANCE SYSTEM

3.1 Quality Assurance Flow Chart

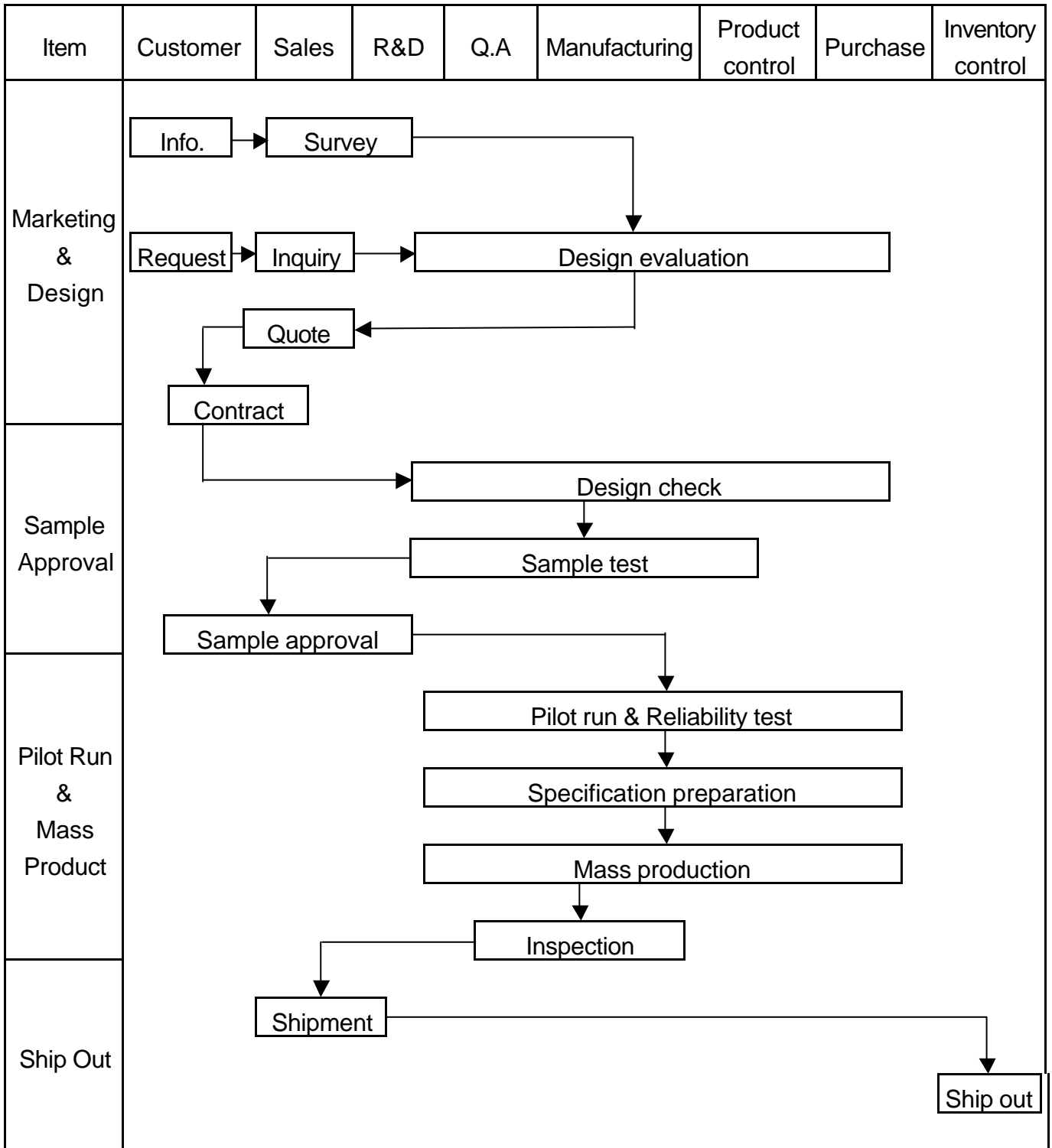

<p>Sales Service</p>	<pre> graph TD Info[Info.] --> Claim[Claim] Claim --> Failure[Failure analysis] Claim --> Report[Analysis report] Failure --> Action[Corrective action] Action --> Tracking[Tracking] </pre>
<p>Q.A Activity</p>	<ol style="list-style-type: none"> 1. ISO 9001 Maintenance Activities 2. Process improvement proposal 3. Equipment calibration 4. Education And Training Activities 5. Standardization Management



3.2 Inspection Specification

Inspection Standard : MIL-STD-105E Table Normal Inspection Single Sampling Level .

Equipment : Gauge、MIL-STD、Powertip Tester、Sample。

IQC Defect Level : Major Defect AQL 0.65; Minor Defect AQL 1.0。

FQC Defect Level : 100% Inspection。

OUT Going Defect Level : Sampling。

Specification :

NO	Item	Specification	Judge	Level
1	Part Number	Inconsistent with the P/N on the flow chart of production	N.G.	Major
2	Quantity	Inconsistent Q'TY with the flow chart of production	N.G.	Major
3	Electronic characteristics $A = (L + W) \div 2$	Display short	N.G.	Major
		Missing line	N.G.	Major
		Dot missing $A > 1/2$ Dot size	N.G.	Major
		No function	N.G.	Major
		Out put data error	N.G.	Major
4	Appearance $A = (L + W) \div 2$ Dirty particle (Include scratch、bubble)	Material difference with flow chart	N.G.	Major
		LCD Assembled in opposite direction	N.G.	Major
		Bezel assembled in opposite direction	N.G.	Major
		Shadow within LCD $V./A + 1.0$ mm	N.G.	Major
		Dirty particle $A > 0.4$ mm	N.G.	Minor
		Dirty particle length > 3.0 mm And $0.01\text{mm} < \text{Width} < 0.05\text{mm}$ (Width $> 0.05\text{mm}$ Measure by area)	N.G.	Minor
		Without protective film	N.G.	Minor
		Conductive rubber over bezel	N.G.	Minor
5	PCB Appearance $A = (L + W) \div 2$	Burned PCB	N.G.	Major
		Green paint stripped & visible circuit $A > 1.0$ mm (Finish coat not counted in)	N.G.	Minor
		A particle across the circuit	N.G.	Minor
		Circuit split $> 1/2$ Circuit width	N.G.	Minor
		Any circuit risen	N.G.	Minor
		$0.2\text{mm} < \text{Tin ball area} A < 0.4\text{mm}$ And Q'TY > 4 Pieces	N.G.	Minor
		Tin ball area $A > 0.4\text{mm}$	N.G.	Minor



POWERTIP TECHNOLOGY CORPORATION

DISPLAY DEVICES FOR BETTER ELECTRONIC DESIGN

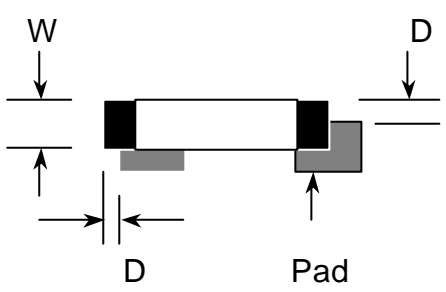
NO	Item	Specification	Judge	Level
6	Molding appearance $A=(L+W) \div 2$	Too soft : Shape by touch changed	N.G.	Major
		Insufficient epoxy : IC circuit or IC pad visible	N.G.	Minor
		Excessive epoxy : Diameter > 20mm Or High > 2.5mm	N.G.	Minor
		Pin hole through to IC and A > 0.2mm	N.G.	Minor
7	Bezel appearance $A=(L+W) \div 2$	Angle between frame and TAB > 45 +10	N.G.	Minor
		Electroplate strip A > 1.0mm (Top view only)	N.G.	Minor
		Rust (Top view only)	N.G.	Minor
		Crack	N.G.	Minor
8	Backlight electric characteristics $A=(L+W) \div 2$	Error backlight color	N.G.	Major
		No function	N.G.	Major
		Any LED dot no function	N.G.	Major
		PIN soldering without tin A > 1/2 solder pad	N.G.	Minor
		Solder PIN high > 1.5mm	N.G.	Minor
9	LCD Appearance $A=(L+W) \div 2$	Polarize rise over V/A	N.G.	Minor
10	Assembly parts $A=(L+W) \div 2$	Components mark unclearly	N.G.	Minor
		Components' distance more than 0.7mm from the PCB	N.G.	Minor
		Error position ,not in center $D > 1/4W$	N.G.	Minor
				
		Non- solder area > Twice solder area	N.G.	Minor
		Flux area A > 1/4 solder area	N.G.	Minor
		Component broken	N.G.	Minor



4. RELIABILITY TEST

4.1 Reliability Test Condition

NO	Item	Test Condition	Applicable Standard
1	High Temperature Storage	Storage At 80 ± 2 96~100 hrs Surrounding Temperature , Then Storage At Normal Condition 4hrs.	MIL-202E
2	Low Temperature Storage	Storage At -30 ± 2 96~100 hrs Surrounding Temperature, Then Storage At Normal Condition 4hrs.	MIL-202E
3	High Temperature Humidity Storage	1.Storage 96~100 hrs 60 ± 2 , 90~95%RH Surrounding Temperature, Then Storage At Normal Condition 4hrs .(Polarizer may fail in this environment). or 2.Storage 96~100 hrs 40 ± 2 , 90~95%RH Surrounding Temperature, Then Storage At Normal Condition 4 hrs.	MIL-202E
4	Temperature Cycling	-20 25 70 25 (30Mins) (5Mins) (30Mins) (5Mins) 10 Cycle	MIL-202E
5	Vibration	10~55Hz (1 Minute) 1.5mm X,Y And Z Direction * (Each 2hrs)	MIL-202E
6	Drop Test	Packing Weight (Kg)	Drop High (Cm)
		0 ~ 45.4	122
		45.4 ~ 90.8	76
		90.8 ~ 454	61
		Over 454	46
			MIL-810E



POWERTIP TECHNOLOGY CORPORATION

DISPLAY DEVICES FOR BETTER ELECTRONIC DESIGN

5. PRECAUTION RELATING PRODUCT HANDLING

5.1 SAFETY

- 5.1.1 If the LCD panel breaks , be careful not to get the liquid crystal to touch your skin.
- 5.1.2 If the liquid crystal touches your skin or clothes , please wash it off immediately by using soap and water.

5.2 HANDLING

- 5.2.1 Avoid any strong mechanical shock which can break the glass.
- 5.2.2 Avoid static electricity which can damage the CMOS LSI—When working with the module , be sure to ground your body and any electrical equipment you may be using.
- 5.2.3 Do not remove the panel or frame from the module.
- 5.2.4 The polarizing plate of the display is very fragile. So , please handle it very carefully , do not touch , push or rub the exposed polarizing with anything harder than an HB pencil lead (glass , tweezers , etc.)
- 5.2.5 Do not wipe the polarizing plate with a dry cloth , as it may easily scratch the surface of plate.
- 5.2.6 Do not touch the display area with bare hands , this will stain the display area.
- 5.2.7 Do not use ketonics solvent & aromatic solvent. Use with a soft cloth soaked with a cleaning naphtha solvent.

5.3 STORAGE

- 5.3.1 Store the panel or module in a dark place where the temperature is 25 ± 5 and the humidity is below 65% RH.
- 5.3.2 Do not place the module near organics solvents or corrosive gases.
- 5.3.3 Do not crush , shake , or jolt the module.



5.4 TERMS OF WARRANTY

5.4.1 Applicable warrant period

The period is within thirteen months since the date of shipping out under normal using and storage conditions.

5.4.2 Unaccepted responsibility

This product has been manufactured to your company' s specification as a part for use in your company' s general electronic products. It is guaranteed to perform according to delivery specifications. For any other use apart from general electronic equipment , we cannot take responsibility if the product is used in medical devices , nuclear power control equipment , aerospace equipment , fire and security systems or any other applications in which there is a direct risk to human life and where extremely high levels

