



Dual Output DC-DC & Linear Regulator IC

The 34710 is a dual-output power regulator IC integrating switching regulator, linear regulator, supervisory and power supply sequencing circuitry. With a wide operating input voltage range of 13 V to 32 V, the 34710 is applicable to many commercial and industrial applications using embedded MCUs.

A mode-selected 5.0 V or 3.3 V DC-DC switching regulator is provided for board-level I/O and user circuitry up to 700 mA. A linear regulator provides mode-selected core supply voltages of either 3.3V, 2.5V, 1.8V, or 1.5V at currents up to 500 mA.

The supervisor circuitry ensures that the regulator outputs follow a predetermined power-up and power-down sequence.

Features

- Efficient 5.0 V/3.3 V Buck Regulator
- Low Noise LDO Regulator (mode-selected 3.3V, 2.5V, 1.8V, or 1.5V)
- On-Chip Thermal Shutdown Circuitry
- Supervisory Functions (Power-ON Reset and Error Reset Circuitry)
- Sequenced I/O and Core Voltages
- Pb-Free Packaging Designated by Suffix Code EW

33710
34710

**DUAL OUTPUT DC-DC & LINEAR
 REGULATOR**



DW SUFFIX
EW SUFFIX (PB-FREE)
98ASA10627D
32-TERMINAL SOICW

ORDERING INFORMATION		
Device	Temperature Range (T _A)	Package
*PC33710EW/R2	-40°C to 105°	32 SOICW-EP
MC34710EW/R2	0°C to 85°C	32 SOICW-EP

*Device in development.
 Electrical parameters being defined.

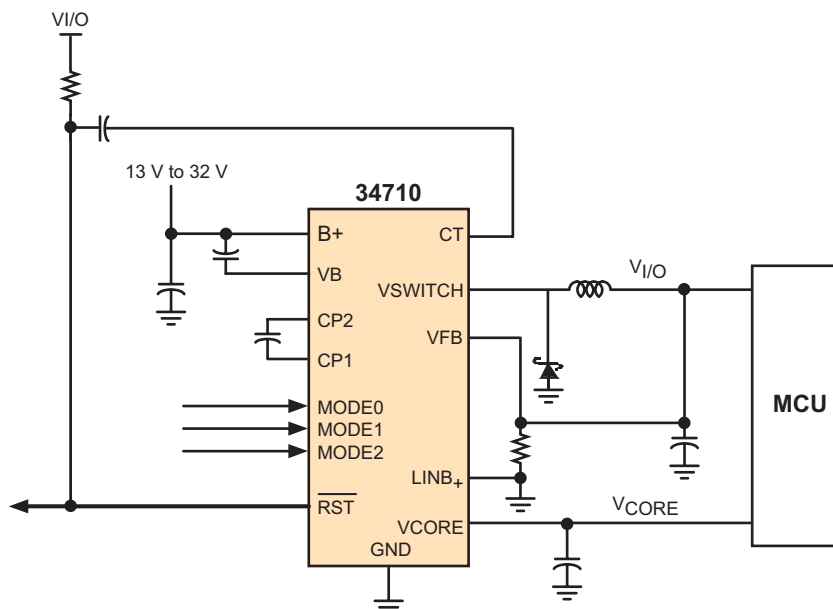

Figure 1. 34710 Simplified Application Diagram

* This document contains certain information on a new product. Specifications and information herein are subject to change without notice.

INTERNAL BLOCK DIAGRAM

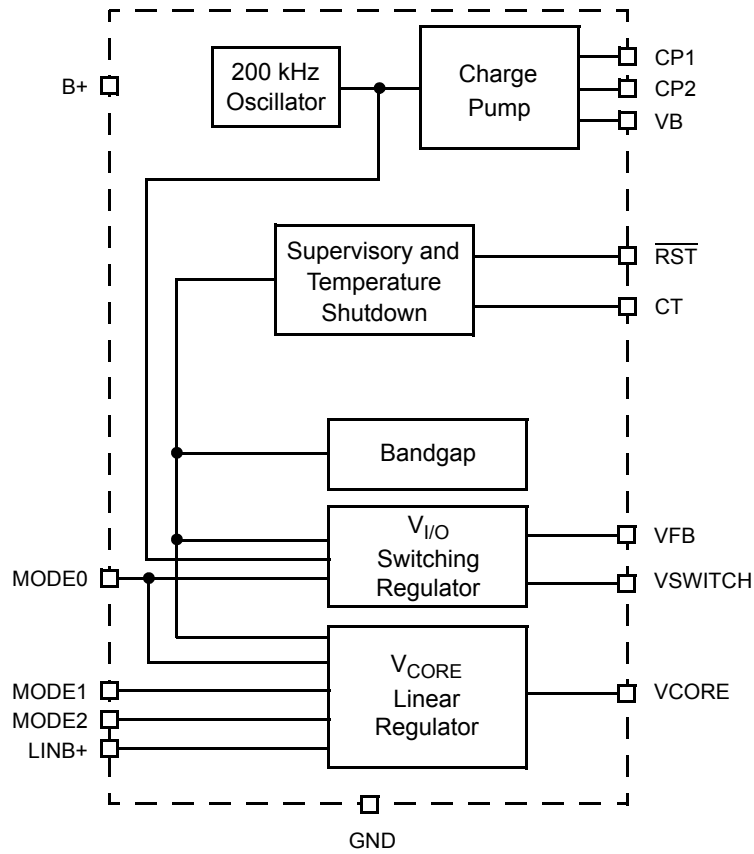

Figure 2. 34710 Simplified Internal Block Diagram

TERMINAL CONNECTIONS

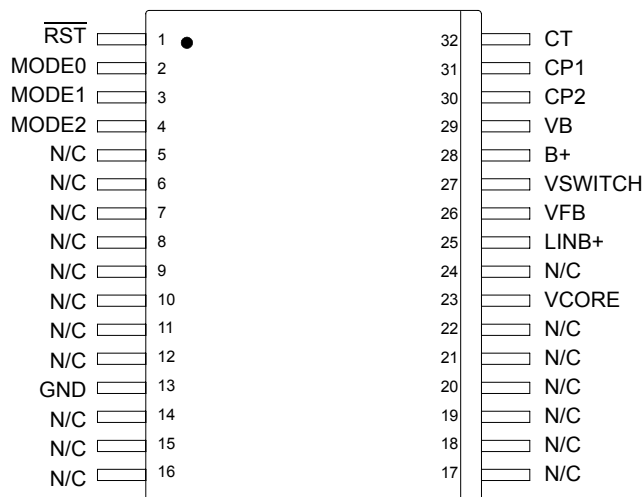

Figure 3. 34710 Terminal Connections

Table 1. 34710 Terminal Definitions

Terminal Number	Terminal Name	Terminal Function	Formal Name	Definition
1	$\overline{\text{RST}}$	Reset	Reset	Reset is an open drain output only.
2 3 4	Mode0 Mode1 Mode2	Input	Mode Control	These input terminals control V_{FB} and V_{CORE} output voltages.
5–12, 14–22, 24	NC	NC	No Connects	No internal connection to this terminal.
13	GND	Ground	Ground	Ground.
23	VCORE	Output	Core Voltage Regulator Output	Core regulator output voltage.
25	LINB+	Input	Core Voltage Regulator Input	Core regulator input voltage.
26	VFB	Input	$V_{\text{I/O}}$ Switching Regulator Feedback	Feedback terminal for $V_{\text{I/O}}$ switching regulator and internal logic supply.
27	VSWITCH	Output	$V_{\text{I/O}}$ Switching Regulator Switch Output	$V_{\text{I/O}}$ switching regulator switching output.
28	B+	Input	Power Supply Input	Regulator input voltage.
29	VB	Output	Boost Voltage	Boost voltage storage node.
30	CP2	Passive Component	CP Capacitor Positive	Charge pump capacitor connection 2.
31	CP1	Passive Component	CP Capacitor Negative	Charge pump capacitor connection 1.
32	CT	Passive Component	Reset Delay Capacitor	Reset delay adjustment capacitor.

MAXIMUM RATINGS

MAXIMUM RATINGS

All voltages are with respect to ground unless otherwise noted. Exceeding these ratings may cause a malfunction or permanent damage to the device.

Rating	Symbol	Max	Unit
--------	--------	-----	------

ELECTRICAL RATINGS

Input Power Supply Voltage $I_{B+} = 0.0 \text{ A}$	V_{B+}	-0.3 to 36	V
Terminal Soldering Temperature ⁽¹⁾	T_{SOLDER}	260	°C
Power Dissipation ⁽²⁾	P_D	3.0	W
ESD Standoff Voltage Non-Operating, Unbiased, Human Body Model ⁽³⁾	V_{ESD1}	±2000	V
Thermal Resistance Junction-to-Ambient ⁽⁴⁾ Junction-to-Ambient ⁽²⁾ Junction-to-Exposed-Pad	$R_{\theta\text{JA}}$ $R_{\theta\text{JA}}$ $R_{\theta\text{JC}}$	45 25 2.0	°C/W

THERMAL RATINGS

Operating Ambient Temperature	T_A	0 to 85	°C
Operating Junction Temperature	T_J	0 to 105	°C
Input Power Supply Voltage $I_{B+} = 0.0 \text{ A to } 3.0 \text{ A}$	V_{B+}	13 to 32	V
Quiescent Bias Current from B+ ⁽⁵⁾ $V_{B+} = 13 \text{ V to } 32 \text{ V}$	$I_{B+}(\text{Q})$	7.5	mA

$V_{I/O}$ SWITCHING REGULATOR ⁽⁶⁾

Maximum Output Voltage Startup Overshoot ($C_{\text{OUT}} = 330 \mu\text{F}$) Mode0 = 0 Mode0 = Open	$V_{I/O}(\text{STARTUP})$	5.4 3.6	V
Maximum Output Current $T_A = 0^\circ\text{C to } 105^\circ\text{C}$	$I_{V_{I/O}}$	700	mA

Notes

- Soldering temperature limit is for 10 seconds maximum duration. Not designed for immersion soldering. Exceeding these limits may cause malfunction or permanent damage to the device.
- With 2.0 in² of copper heatsink.
- ESD1 testing is performed in accordance with the Human Body Model ($C_{\text{ZAP}} = 100 \text{ pF}$, $R_{\text{ZAP}} = 1500 \Omega$).
- With no additional heatsinking.
- Maximum quiescent power dissipation is 0.25 W.
- $13 \text{ V} \leq V_{B+} \leq 32 \text{ V}$ and $-20^\circ\text{C} \leq T_J \leq 145^\circ\text{C}$ unless otherwise noted.

MAXIMUM RATINGS (continued)

All voltages are with respect to ground unless otherwise noted. Exceeding these ratings may cause a malfunction or permanent damage to the device.

Rating	Symbol	Max	Unit
V_{CORE} LINEAR REGULATOR ⁽⁷⁾			
Maximum Output Voltage Startup Overshoot (C _{OUT} = 10 μF) ⁽⁸⁾ Mode2=Low, Mode1=Low, Mode0=Low Mode2=Open, Mode1=Low, Mode0=Don't Care Mode2=Low, Mode1=Open, Mode0=Don't Care Mode2=Open, Mode1=Open, Mode0=Don't Care	V _{CORE(STARTUP)}	3.6 2.7 2.0 1.65	V
Maximum Output Current T _J = 0°C to 105°C, V _{LINB+} ≤ V _{CORE(NOM)} + 0.8 V ⁽⁹⁾	I _{VCORE}	500	mA

Notes

7. $13\text{ V} \leq V_{B+} \leq 32\text{ V}$ and $-20^\circ\text{C} \leq T_J \leq 145^\circ\text{C}$ unless otherwise noted.
8. Refer to [Table 2](#), page [9](#).
9. Pulse testing with low duty cycle used.

STATIC ELECTRICAL CHARACTERISTICS

STATIC ELECTRICAL CHARACTERISTICS

Characteristics noted under conditions $4.75\text{ V} \leq V_{I/O} \leq 5.25\text{ V}$, $13\text{ V} \leq V_{B+} \leq 32\text{ V}$, and $0^\circ\text{C} \leq T_J \leq 105^\circ\text{C}$ unless otherwise noted. Typical values noted reflect the approximate parameter mean at $T_A = 25^\circ\text{C}$ under nominal conditions unless otherwise noted.

Characteristic	Symbol	Min	Typ	Max	Unit
SWITCHING REGULATOR (V_{I/O}, MODE0)					
Logic Supply Voltage ($I_{V_{I/O}} = 25$ to 700 mA) Mode0 = 0 Mode0 = Open (floating)	$V_{I/O}$	4.8 3.15	5.0 3.25	5.2 3.45	V
Output On Resistance $V_{B+} = 13\text{ V}$ to 32 V	$R_{DS(ON)}$	0.5	1.0	2.0	Ω
Soft Start Threshold Voltage Mode0 = any	$V_{I/O(SOFT)}$	–	2.5	3.1	V
Current Limit Threshold ($T_J = 25^\circ\text{C}$ to 100°C) Normal Operation Soft Start, $V_{I/O} \leq 2.5\text{ V}$	$I_{LIMIT(OP)}$ $I_{LIMIT(SOFT)}$	1.9 1.0	2.4 –	2.9 1.9	A
Minimum Voltage Allowable on V_{SWITCH} Terminal $T_J = 25^\circ\text{C}$ to 100°C	$V_{VSWITCH(MIN)}$	-0.5	–	–	V

LINEAR REGULATOR (V_{CORE}, MODE 1, 2, 3, 4)

Supply Voltage ($I_{V_{CORE}} = 5.0\text{ mA}$) ⁽¹⁰⁾ Mode2=Low, Mode1=Don't Care, Mode0=Low Mode2=Low, Mode1=Don't Care, Mode0=Open Mode2=Open, Mode1=Don't Care, Mode0=Low Mode2=Open, Mode1=Don't Care, Mode0=Open	$V_{CORE(NOM)}$	3.15 2.45 1.7 1.425	3.3 2.5 1.8 1.5	3.45 2.75 2.05 1.575	V
Supply Voltage ($I_{V_{CORE}} = 500\text{ mA}$) ⁽¹⁰⁾ Mode2=Low, Mode1=Don't Care, Mode0=Low Mode2=Low, Mode1=Don't Care, Mode0=Open Mode2=Open, Mode1=Don't Care, Mode0=Low Mode2=Open, Mode1=Don't Care, Mode0=Open	$V_{CORE(NOM)}$	3.0 2.2 1.55 1.33	– – – –	3.4 2.6 1.9 1.53	V
V_{CORE} Dropout Voltage $V_{CORE} = V_{CORE(NOM)}$, $I_{V_{CORE}} = 0.5\text{ A}$	$I_{V_{CORE}(DROPOUT)}$	–	0.5	0.8	V
Normal Current Limit Threshold $T_J = 25^\circ\text{C}$ to 100°C , $V_{LINB+} = V_{CORE(NOM)} + 1.0\text{ V}$	I_{LIMIT}	600	800	1000	mA

Notes

10. Refer to [Table 2](#), page [9](#).

STATIC ELECTRICAL CHARACTERISTICS (continued)

Characteristics noted under conditions $4.75\text{ V} \leq V_{IO} \leq 5.25\text{ V}$, $13\text{ V} \leq V_{B+} \leq 32\text{ V}$, and $0^\circ\text{C} \leq T_J \leq 105^\circ\text{C}$ unless otherwise noted. Typical values noted reflect the approximate parameter mean at $T_A = 25^\circ\text{C}$ under nominal conditions unless otherwise noted.

Characteristic	Symbol	Min	Typ	Max	Unit
----------------	--------	-----	-----	-----	------

MODE TERMINALS OPERATING VOLTAGES

Mode Control Terminals Low Voltage	$V_{IL}(\text{Mode}_n)$	–	–	0.825	V
Mode Control Terminals High Voltage	$V_{IH}(\text{Mode}_n)$	2.6	–	–	V
Mode Control Terminals Voltage with Input Floating $V_{B+} = 13\text{ V to }14\text{ V}$	$V_{\text{Mode}}(\text{FLOAT})$	7.0	8.0	13	V

SUPERVISOR CIRCUITRY ($\overline{\text{RST}}$, V_{CORE})

Minimum Function V_{B+} for Charge Pump and Oscillator Running	$V_{B+}(\text{MIN})$	–	–	9.0	V
Minimum V_{B+} for $\overline{\text{RST}}$ Assertion, V_{B+} Rising	$V_{B+}(\text{ASSERT})$	–	1.9	2.2	V
$\overline{\text{RST}}$ Low Voltage $V_{B+} = 2.0\text{ V}$, $I_{\overline{\text{RST}}} \leq 5.0\text{ mA}$	V_{OL}	–	0.25	0.4	V
$\overline{\text{RST}}$ V_{IO} Threshold V_{IO} Rising V_{IO} Falling	$V_{IO\text{T}+}$ $V_{IO\text{T}-}$	– $V_{IO}(\text{NOM})$ – 300 mV	– –	$V_{IO}(\text{NOM})$ – 50 mV –	V
$\overline{\text{RST}}$ Hysteresis for V_{IO}	$V_{\text{HYS}V_{IO}}$	10	–	100	mV
$\overline{\text{RST}}$ V_{CORE} Threshold V_{CORE} Rising V_{CORE} Falling	$V_{\text{CORE}+}$ $V_{\text{CORE}-}$	– $V_{\text{CORE}}(\text{NOM})$ – 300 mV	– –	$V_{\text{CORE}}(\text{NOM})$ – 30 mV –	V
$\overline{\text{RST}}$ Hysteresis for V_{CORE} $V_{B+} = 13\text{ V to }32\text{ V}$	$V_{\text{HYS CORE}}$	10	50	100	mV
$V_{\text{CORE}} - V_{IO}$ for V_{CORE} Shutdown $V_{B+} = 13\text{ V to }32\text{ V}$	$V_{\text{CORE}}(\text{SHUTDOWN})$	0.5	–	0.9	V
Thermal Shutdown Temperature T_J Rising	$T_J(\text{TSD})$	–	–	170	$^\circ\text{C}$
Overtemperature Hysteresis	$T_J(\text{HYSTERESIS})$	–	20	–	$^\circ\text{C}$

VB CHARGE PUMP

Boost Voltage ⁽¹¹⁾ $V_{B+} = 12\text{ V}$, $I_{Vb} = 0.5\text{ mA}$ $V_{B+} = 32\text{ V}$, $I_{Vb} = 0.5\text{ mA}$	V_B V_B	V_{B+8} V_{B+10}	V_{B+9} V_{B+12}	V_{B+10} V_{B+14}	V
---	----------------	-------------------------	-------------------------	--------------------------	---

Notes

11. Bulk capacitor ESR ≤ 10 milliohms

DYNAMIC ELECTRICAL CHARACTERISTICS

DYNAMIC ELECTRICAL CHARACTERISTICS

Characteristics noted under conditions $4.75\text{ V} \leq V_{IO} \leq 5.25\text{ V}$, $13\text{ V} \leq V_{B+} \leq 32\text{ V}$, and $0^\circ\text{C} \leq T_J \leq 105^\circ\text{C}$ unless otherwise noted. Typical values noted reflect the approximate parameter mean at $T_A = 25^\circ\text{C}$ under nominal conditions unless otherwise noted

Characteristic	Symbol	Min	Typ	Max	Unit
----------------	--------	-----	-----	-----	------

V_{IO} SWITCHING REGULATOR

Duty Cycle	D	45	49	55	%
Switching Rise and Fall Time Load Resistance = 100 Ω , $V_{B+} = 30\text{ V}$	t_R, t_F	20	35	50	ns

SUPERVISOR CIRCUITRY (RST)

$\overline{\text{RST}}$ Delay $C_{\text{delay}} = 0.1\ \mu\text{F}$	t_{DELAY}	40	60	80	ms
$\overline{\text{RST}}$ Filter Time $V_{B+} = 9.0\text{ V}$	t_{FILTER}	2.0	4.0	8.0	μs
$\overline{\text{RST}}$ Fall Time $C_L = 100\ \text{pF}$, $R_{\text{PULLUP}} = 4.7\ \text{k}\Omega$, 90% to 10%	t_F	–	25	75	ns
C Delay Charge Current Threshold Voltage	I_{CDLY} V_{THCD}	2.0 1.7	3.5 2.0	5.0 2.2	μA V

INTERNAL OSCILLATOR

Charge Pump and V _{IO} Switching Regulator Operating Frequency $V_{B+} = 12\text{ V to }32\text{ V}$	f_{OP}	140	170	260	kHz
--	-----------------	-----	-----	-----	-----

FUNCTIONAL DESCRIPTION

INTRODUCTION

V_{I/O} Switching Regulator

The V_{I/O} switching regulator output voltage is determined by the Mode digital input terminals. The 34710's Mode terminals select the output voltage. For example, if Mode2, Mode1, and Mode0 are set to 0, 0, 0 (respectively) then V_{I/O} will be set to 5.0 V; if Mode2, Mode1, and Mode0 are all left floating (i.e., Open, Open, and Open), then the voltage for V_{I/O} will be set to 3.3 V. [Table 2](#) provides the truth table for setting the various combination of regulator outputs via the Mode pins.

The topology of the regulator is a hysteretic buck regulator operating from the internal ~200 kHz oscillator.

V_{CORE} Linear Regulator

The V_{CORE} linear LDO (low drop-out) regulator can produce either a +3.3 V, 2.5 V, 1.8 V, or 1.5 V output voltage at currents up to 500 mA. The input to the V_{CORE} regulator is a terminal that may be connected to the V_{I/O} regulator output or to an external power supply. Note, the minimum input voltage level must be equal to or greater than the

selected V_{CORE} voltage + 0.8 V. (i.e., 0.8V is the LDO regulator drop out voltage.)

The Mode terminals select the output voltage as depicted in [Table 2](#).

Table 2. V_{I/O} and V_{CORE} Regulator Output Voltage Selection

Mode2	Mode1	Mode0	V _{I/O} (V)	V _{CORE} (V)
0	0	0	5.0	3.3
0	0	Open	3.3	2.5
0	Open	0	5.0	1.8
0	Open	Open	3.3	1.8
Open	0	0	5.0	2.5
Open	0	Open	3.3	2.5
Open	Open	0	5.0	1.5
Open	Open	Open	3.3	1.5

Open indicates terminal is not connected externally (i.e. floating).

FUNCTIONAL TERMINAL DESCRIPTION

Power Supply Input (B+)

Main supply voltage for the V_{I/O} Switching Regulator and general chip bias circuitry.

Core Voltage Regulator Input (Lin B+)

Supply voltage for the V_{CORE} Regulator. May be provided by the V_{I/O} regulator output or from an independent supply.

Mode Control (MODE 0,1,2)

Mode select terminals to select the V_{I/O} and V_{CORE} output voltages per table 2. Pull to ground for low state, float for high state.

Switching Capacitors 1 and 2 (CP1/CP2)

Terminals for the Charge Pump capacitor.

Boost Voltage (VB)

The Boost Voltage is an output terminal used for the charge pump boost voltage and is a connection point for the Charge Pump bulk capacitor. It provides a gate drive for the V_{I/O} Switch FET.

Reset ($\overline{\text{RST}}$)

Reset is an output terminal for supervisory functions. This terminal is in high state during normal operation and low state

during fault conditions. This terminal has no input function and requires an external pull-up resistor.

The $\overline{\text{RST}}$ terminal is an open drain output driver to prevent oscillations during the transition. It is recommended to connect a 0.1 uF capacitor between the CT pin and $\overline{\text{RST}}$ pin. Note: error conditions must be present for a minimum time, t_{FILTER}, before the 34710 responds to them. Once all error conditions have been cleared, $\overline{\text{RST}}$ is held low for an additional time of t_{DELAY}.

Reset Delay Capacitor (CT)

This terminal is the external delay. It is used with a capacitor to ground to delay $\overline{\text{RST}}$ turn-on time and to $\overline{\text{RST}}$ to prevent $\overline{\text{RST}}$ oscillations during chip power-on.

V_{I/O} Switching Regulator Feedback (VFB)

This terminal is the feedback input for the V_{I/O} Switching Regulator and the output of the regulator application.

V_{I/O} Switching Regulator output (VSWITCH)

This terminal is the Switching output for the V_{I/O} Buck Regulator. It has internal high side FET.

SUPERVISORY FUNCTIONS

Supervisory Circuitry

The supervisory circuitry provides control of the $\overline{\text{RST}}$ line, an open drain signal, based on system operating conditions monitored by the 34710. $V_{\text{I/O}}$, V_{CORE} , $V_{\text{B+}}$, and thermal shutdown (TSD) detectors in various parts of the chip are monitored for error conditions. $V_{\text{I/O}}$, V_{CORE} , $V_{\text{B+}}$, and thermal shutdown have both positive- and negative-going thresholds for triggering the reset function.

The supervisor circuitry also ensures that the regulator outputs follow a predetermined power-up and power-down sequence. Specifically, the sequencing ensures that $V_{\text{I/O}}$ is never less than 0.9 V below V_{CORE} . This means that $V_{\text{CORE}} - V_{\text{I/O}}$ will be clamped at 0.5 V, and that the V_{CORE} regulator

operation will be suppressed during startup and shutdown to ensure that $V_{\text{CORE}} - V_{\text{I/O}} = 0.9 \text{ V}$.

VB Charge Pump

The high-side MOSFET in the switching regulator (buck converter) requires a gate drive supply voltage that is biased higher than the B+ voltage, and this boosted voltage is provided by the internal charge pump and stored in a capacitor between the VB pin and the B+ pin. The charge pump operates directly from the B+ supply, and uses an internal oscillator operating at 200 kHz.

Internal Oscillator

The internal oscillator provides a 200 kHz square wave signal for charge pump operation and for the buck converter.

TYPICAL APPLICATIONS

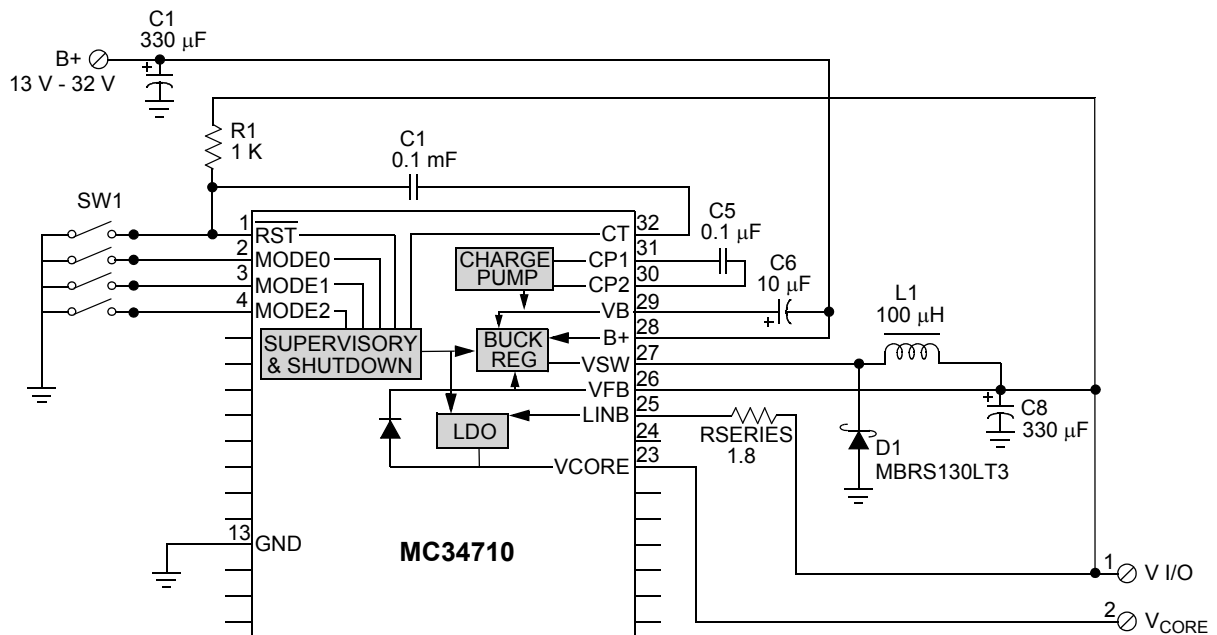

Figure 4. Typical Application Diagram

The MC34710 provides both a buck converter and an LDO regulator in one IC. Figure 4 above shows a typical application schematic for the MC34710. L1 is the buck converter's inductor. The buck inductor is a key component and must not only present the required reactance, but do so at a dc resistance of less than 20 milliohms in order to preserve the converter's efficiency. Also important to the converter's efficiency is the utilization of a low Vf Schottky diode for D1.

Note that a 0.1µF capacitor is connected between CT and the reset pins; this prevents any possibility of oscillations occurring on the reset line during transitions by allowing the CT terminal to discharge to ground potential via the RST pin, and then charge when RST returns to a logic high. The capacitor between the CP1 and CP2 pins is the charge pump's "bucket capacitor", and sequentially charges and discharges to pump up the reservoir capacitor connected to the VB pin. Note that the reservoir capacitor's cathode is connected to B+ rather than ground. Also note that the charge pump is intended only to provide gate-drive potential for the buck regulator's internal power MOSFET, and therefore connecting external loads to the VB pin is not recommended.

The IC's internal V_{CORE} LDO regulator can provide up to 500 mA of current as long as the operating junction

temperature is maintained below 105 degrees C. The heat-generating power dissipation of the LDO is primarily a function of the Volt x Amp product across the LINB+ and V_{CORE} terminals. Therefore, if the LINB+ voltage is >> than the selected V_{CORE} voltage + 0.8 V, it is recommended to use a power resistor in series with the LINB+ input to drop the voltage and dissipate the heat externally from the IC. For example, if the output of the buck regulator (V I/O on the schematic) is used as the input to LINB+, and the mode switches are set such that V I/O = 5 V and V_{CORE} = 3.3 V, then a series resistance of 1.8 ohms at the LINB+ pin would provide an external voltage drop at 500 mA while still leaving the minimum required headroom of 0.8 V. Conversely, if the mode switches are set such that V I/O = 3.3 V and V_{CORE} = 2.5 V, then no series resistance would be required, even at the maximum output current of 500 mA.

Designing a power supply circuit with the MC34710, like all dc-dc converter ICs, requires special attention not only to component selection, but also to component placement (i.e., printed circuit board layout). The MC34710 has a nominal switching frequency of 200 kHz, and therefore pcb traces between the buck converter discrete component terminals and the IC should be kept as short and wide as possible to keep the parasitic inductance low. Likewise, keeping these

pcb traces short and wide helps prevent the converter's high di/dt switching transients from causing EMI/RFI.

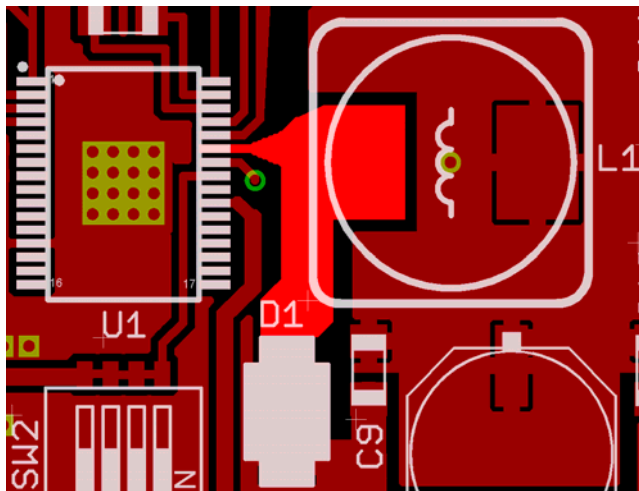

Figure 5. Typical PCB Layout

Figure 5 shows a typical layout for the pcb traces connecting the IC's switching terminal (VSWITCH) and the power inductor, rectifier, and filter components.

Also, it is recommended to design the component layout so that the switching currents can be immediately sunk into a broad full-plane ground that provides terminations physically right at the corresponding component leads. This helps prevent switching noise from propagating into other sections of the circuitry.

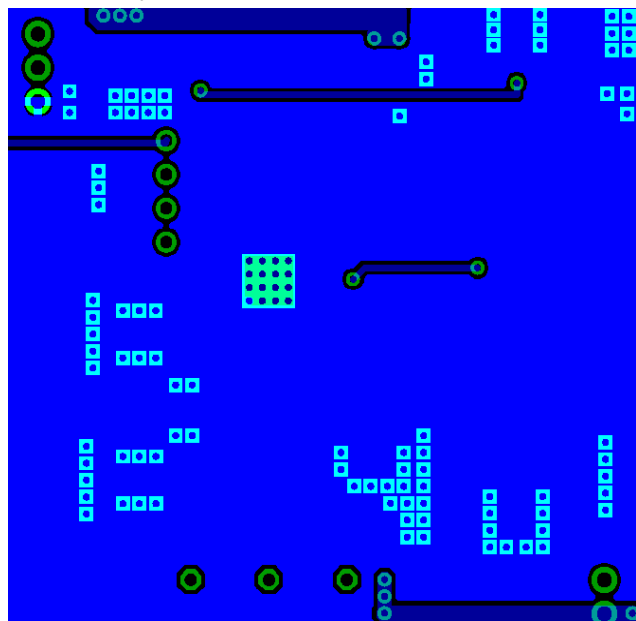

Figure 6. Bottom Copper Layout

Figure 6 illustrates a pcb typical bottom copper layout for the area underneath a buck converter populated on the top of the same section of pcb.

The ground plane is highlighted so the reader may note how the ground plane has been kept as broad and wide as

possible. The square vias in the plane are located to provide an immediate path to ground from the top copper circuitry.

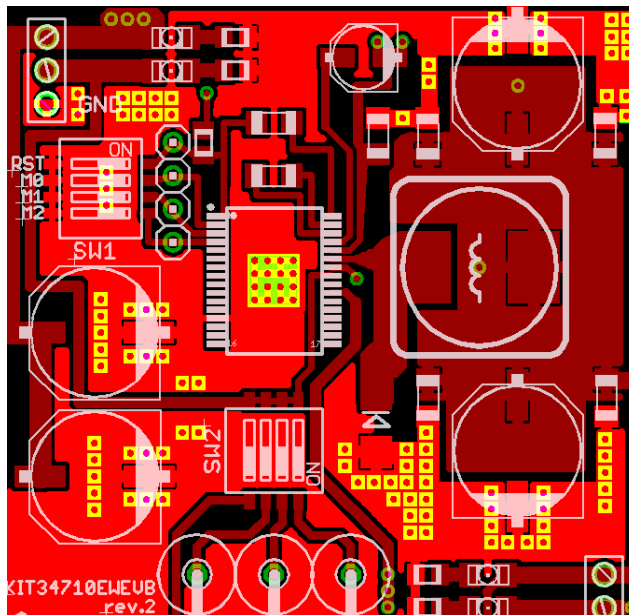

Figure 7. Top Copper Layout

Figure 7 shows the corresponding top copper circuit area with the component placement.

Again, the ground plane and the vias have been highlighted so the reader may note the proximity of these current sink pathways to the key converter components. It is also important to keep the power planes of the switching converter's output spread as broad as possible beneath the passive components, as this helps reduce EMI/RFI and the potential for coupling noise transients into adjacent circuitry.

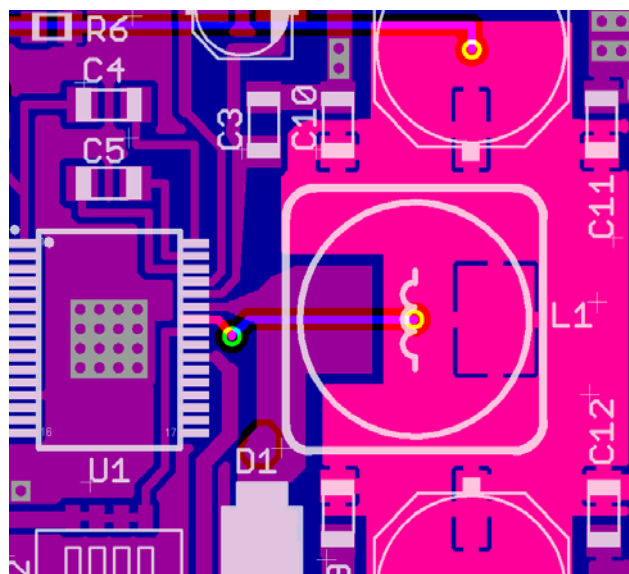

Figure 8. Output Plane of Buck Converter

Figure 8 shows the output plane of the buck converter highlighted.

This layout provides the lowest possible impedance as well as lowest possible dc resistance for the power routing. Note that the power path and its return should be placed, if possible, on top of each other on different layers or opposite sides of the pcb.

Small ceramic capacitors are placed in parallel with the Aluminum electrolytics so that the overall bulk filtering presents a low ESL to the high di/dt switching currents. Alternatively, special low ESL/ESR switching-grade electrolytics may be used.

An additional feature of the MC34710 is the 32 SOICW-EP exposed pad package. The package allows heat to be conducted from the die down through the exposed metal pad underneath the package and into the copper of the pcb. In order to best take advantage of this feature, a grid array of thru-hole vias should be placed in the area corresponding to the exposed pad, and these vias then should then connect to a large ground plane of copper to dissipate the heat into the ambient environment. An example of these vias can be seen in the previous figures of a typical pcb layout.

PACKAGING

PACKAGE DIMENSIONS

EW (Pb-FREE) SUFFIX
32-LEAD SOICW-EXPOSED PAD
PLASTIC PACKAGE
98ASA10627D
ISSUE O

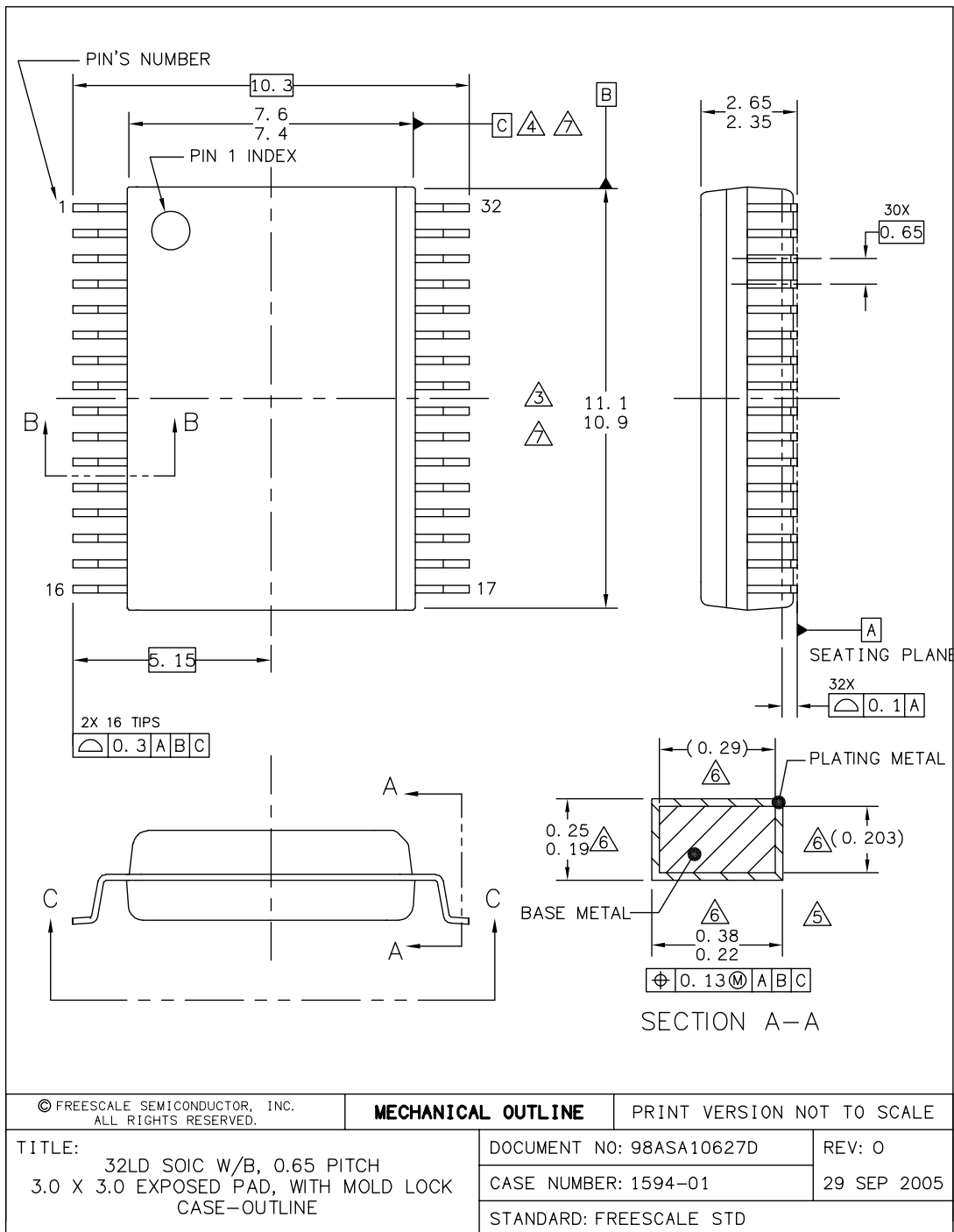

EW (Pb-FREE) SUFFIX
32-LEAD SOICW-EXPOSED PAD
PLASTIC PACKAGE
98ASA10627D
ISSUE 0

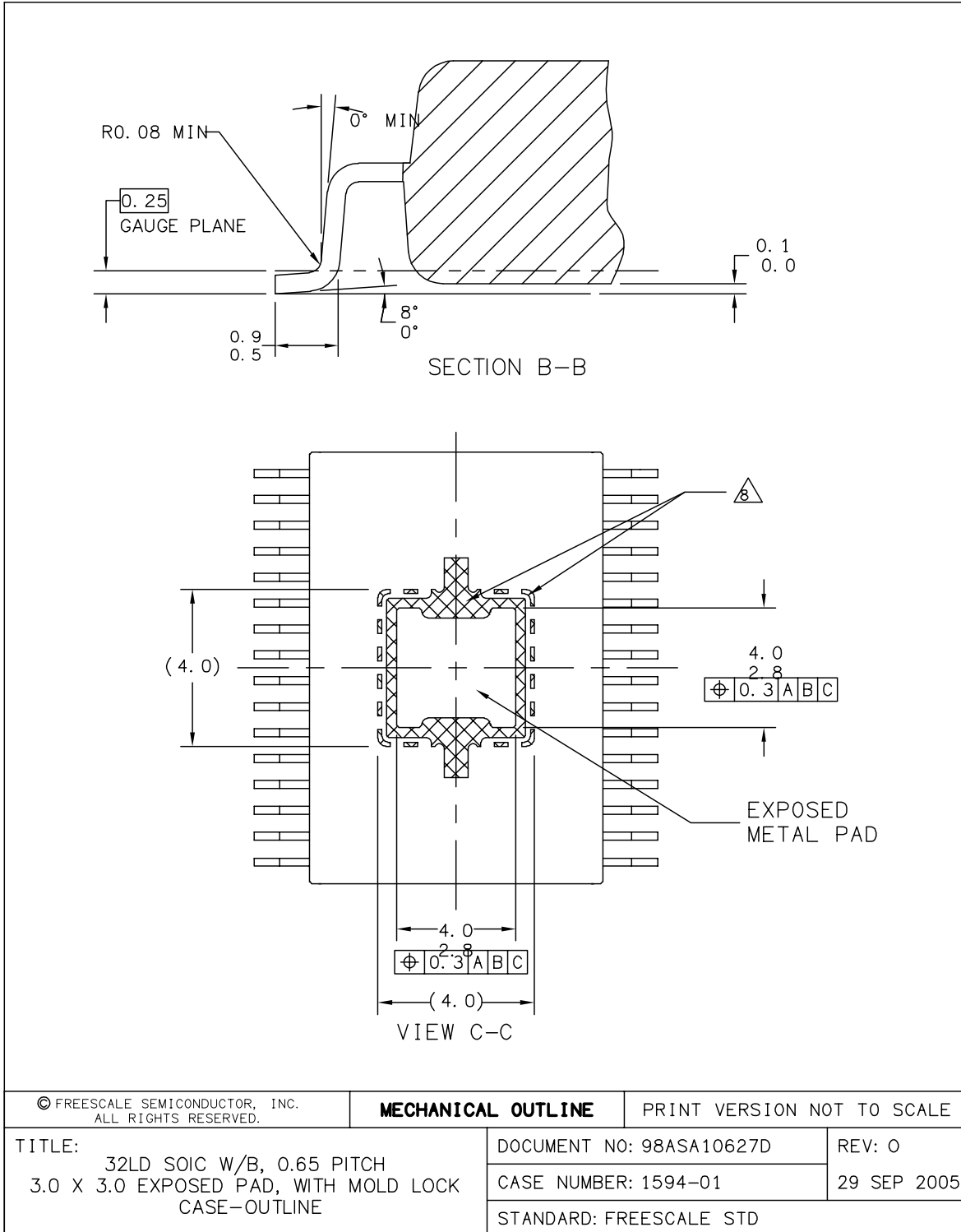

REVISION HISTORY

REVISION	DATE	DESCRIPTION OF CHANGES
2.0	3/2006	<ul style="list-style-type: none">• Converted to Freescale format• Updated Maximum Ratings, Static and Dynamic Characteristics tables.• Updated packaging drawing• Changed terminal VI/O_OUT to VFB• Implemented Revision History page
3.0	3/2006	<ul style="list-style-type: none">• Updated format from Preliminary to Advance Information.• Format and style corrections to match standard template.

How to Reach Us:

Home Page:

www.freescale.com

E-mail:

support@freescale.com

USA/Europe or Locations Not Listed:

Freescale Semiconductor
Technical Information Center, CH370
1300 N. Alma School Road
Chandler, Arizona 85224
+1-800-521-6274 or +1-480-768-2130
support@freescale.com

Europe, Middle East, and Africa:

Freescale Halbleiter Deutschland GmbH
Technical Information Center
Schatzbogen 7
81829 Muenchen, Germany
+44 1296 380 456 (English)
+46 8 52200080 (English)
+49 89 92103 559 (German)
+33 1 69 35 48 48 (French)
support@freescale.com

Japan:

Freescale Semiconductor Japan Ltd.
Headquarters
ARCO Tower 15F
1-8-1, Shimo-Meguro, Meguro-ku,
Tokyo 153-0064
Japan
0120 191014 or +81 3 5437 9125
support.japan@freescale.com

Asia/Pacific:

Freescale Semiconductor Hong Kong Ltd.
Technical Information Center
2 Dai King Street
Tai Po Industrial Estate
Tai Po, N.T., Hong Kong
+800 2666 8080
support.asia@freescale.com

For Literature Requests Only:

Freescale Semiconductor Literature Distribution Center
P.O. Box 5405
Denver, Colorado 80217
1-800-441-2447 or 303-675-2140
Fax: 303-675-2150
LDCForFreescaleSemiconductor@hibbertgroup.com

RoHS-compliant and/or Pb-free versions of Freescale products have the functionality and electrical characteristics of their non-RoHS-compliant and/or non-Pb-free counterparts. For further information, see <http://www.freescale.com> or contact your Freescale sales representative.

For information on Freescale's Environmental Products program, go to <http://www.freescale.com/epp>.

Information in this document is provided solely to enable system and software implementers to use Freescale Semiconductor products. There are no express or implied copyright licenses granted hereunder to design or fabricate any integrated circuits or integrated circuits based on the information in this document.

Freescale Semiconductor reserves the right to make changes without further notice to any products herein. Freescale Semiconductor makes no warranty, representation or guarantee regarding the suitability of its products for any particular purpose, nor does Freescale Semiconductor assume any liability arising out of the application or use of any product or circuit, and specifically disclaims any and all liability, including without limitation consequential or incidental damages. "Typical" parameters that may be provided in Freescale Semiconductor data sheets and/or specifications can and do vary in different applications and actual performance may vary over time. All operating parameters, including "Typicals", must be validated for each customer application by customer's technical experts. Freescale Semiconductor does not convey any license under its patent rights nor the rights of others. Freescale Semiconductor products are not designed, intended, or authorized for use as components in systems intended for surgical implant into the body, or other applications intended to support or sustain life, or for any other application in which the failure of the Freescale Semiconductor product could create a situation where personal injury or death may occur. Should Buyer purchase or use Freescale Semiconductor products for any such unintended or unauthorized application, Buyer shall indemnify and hold Freescale Semiconductor and its officers, employees, subsidiaries, affiliates, and distributors harmless against all claims, costs, damages, and expenses, and reasonable attorney fees arising out of, directly or indirectly, any claim of personal injury or death associated with such unintended or unauthorized use, even if such claim alleges that Freescale Semiconductor was negligent regarding the design or manufacture of the part.

Freescale™ and the Freescale logo are trademarks of Freescale Semiconductor, Inc. All other product or service names are the property of their respective owners.

© Freescale Semiconductor, Inc., 2006. All rights reserved.