

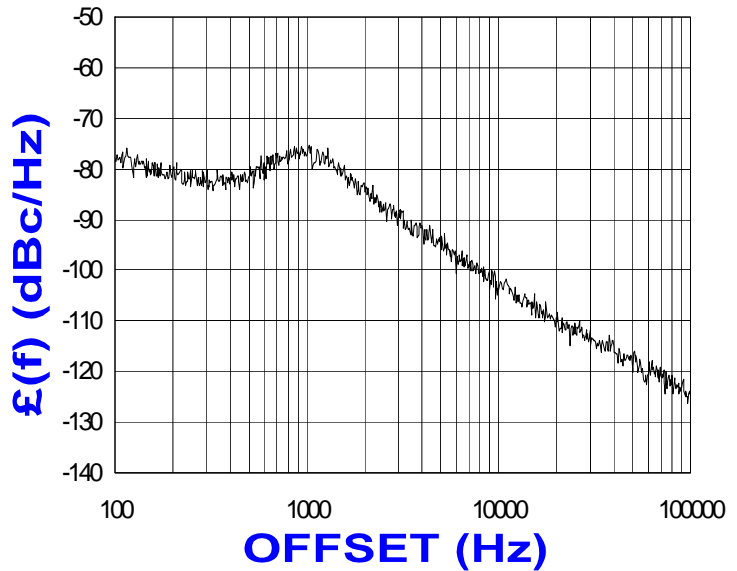

**PHASE NOISE (1 Hz BW, typical)**



**FEATURES**

- Frequency Range: 1500 - 1600 MHz
- Step Size: 1000 KHz
- cPLL - Style Package

**APPLICATIONS**

- Fixed Wireless Broadband Equipment
- Point-to-Point Microwave Radio
- Satellite Communication Systems

PERFORMANCE SPECIFICATIONS	VALUE	UNITS
Frequency Range	1500 - 1600	MHz
Phase Noise @ 10 kHz offset (1 Hz BW, typ.)	-103	dBc/Hz
Harmonic Suppression (2nd, typ.)	-20	dBc
Sideband Spurs (typ.)	-70	dBc
Power Output	1.5±2.5	dBm
Load Impedance	50	Ω
Step Size	1000	KHz
Charge Pump Output Current	1250	μA
Switching Speed (typ., adjacent channel)	2	mSec
Startup Lock Time (typ.)	3	mSec
Operating Temperature Range	-40 to 85	°C
Package Style	cPLL	
POWER SUPPLY REQUIREMENTS		
Supply Voltage (Vcc, nom.)	5	Vdc
Supply Current (Icc, typ.)	37	mA

All specifications are typical unless otherwise noted and subject to change without notice.

**APPLICATION NOTES**

- AN-107 : How to Solder Z-COMM VCOs / PLLs
- AN-200 : Mounting and Grounding of Z-COMM PLLs
- AN-201 : PLL Fundamentals      AN-202 : PLL Functional Description

**NOTES:**

Reference Oscillator Signal: 5 MHz <math>f\_{osc}</math> <math>< 100</math> MHz  
 Frequency Synthesizer: Analog Devices - ADF4113

VCO TUNING CURVE, typ.

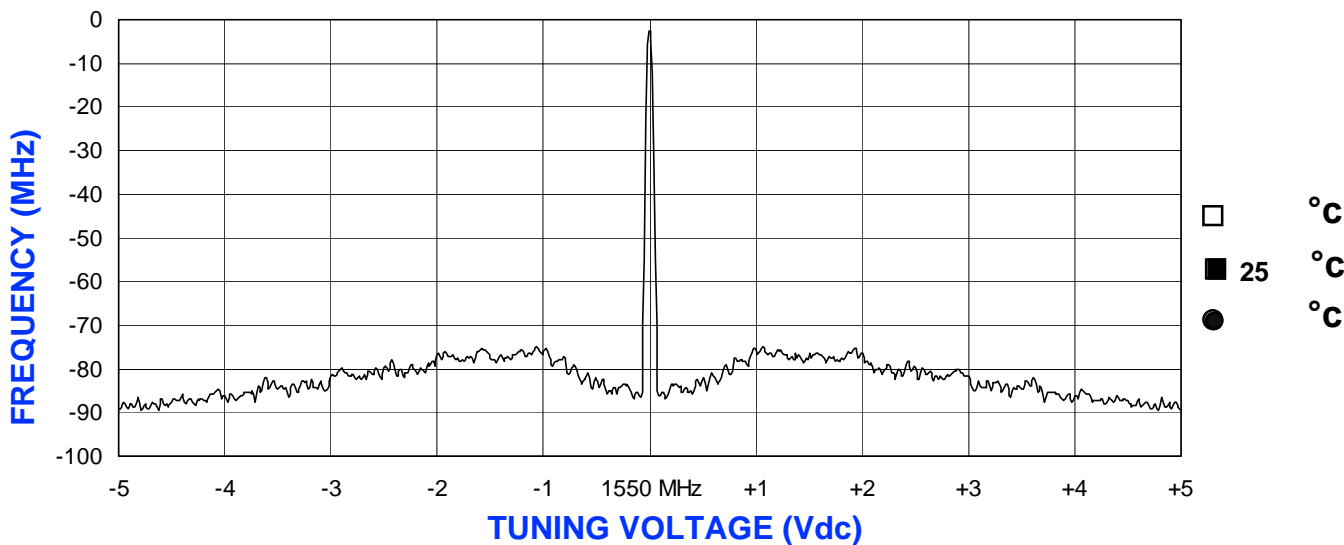

VCO POWER CURVE, typ.

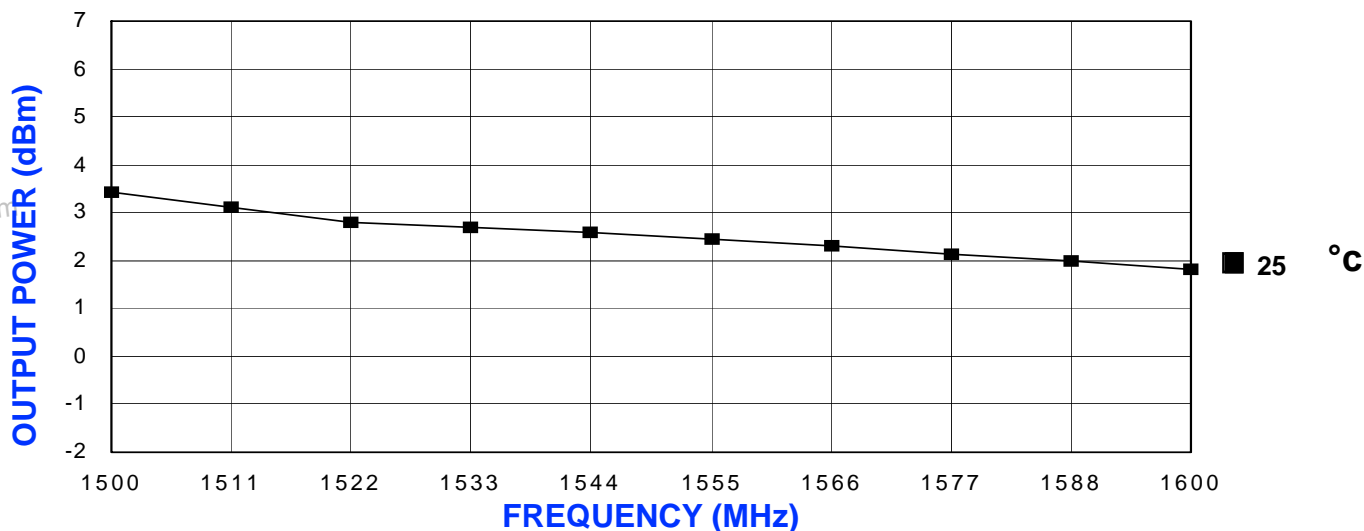

PHYSICAL DIMENSIONS

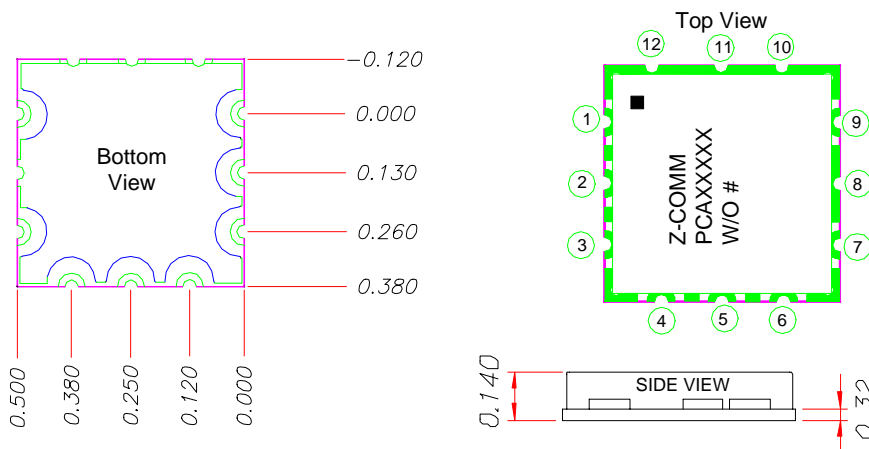

1. The inside radius of all 14 half holes at the perimeter of the board are plated to provide a surface for the attachment of the PLL Module to the motherboard. 5 pads are for grounding, 8 pads are for signal interface.
2. The surface of the shield is tin-plated and may be soldered to. The shield's base metal is brass.
3. The ground plane on the bottom side is ground and attaches to a ground track on the top side of the board as well as to the shield.
4. Unless otherwise noted all dimensions are in inches.
5. Unless otherwise noted all tolerances are as follows:  
...xx = ± .010

- P1 RF OUTPUT
- P2 REFERENCE OSCILLATOR INPUT
- P3 CLOCK
- P4 DATA
- P5 LOAD ENABLE
- P6 LOCK DETECT
- P7 VCC
- P8 GROUND
- P9 NO CONNECTION
- P10-12 GROUND