

DATA SHEET

PCA82C251

CAN transceiver for 24 V systems

Preliminary specification
Supersedes data of 1995 Oct 26
File under Integrated Circuits, IC18

1997 Mar 14

CAN transceiver for 24 V systems**PCA82C251****FEATURES**

- Fully compatible with the "ISO 11898 - 24 V" standard
- Slope control to reduce RFI
- Thermally protected
- Short-circuit proof to battery and ground in 24 V powered systems
- Low current standby mode
- An unpowered node does not disturb the bus lines
- At least 110 nodes can be connected
- High speed (up to 1 Mbaud)
- High immunity against electromagnetic interference.

GENERAL DESCRIPTION

The PCA82C251 is the interface between the CAN protocol controller and the physical bus. It is primarily intended for applications (up to 1 Mbaud) in trucks and buses. The device provides differential transmit capability to the bus and differential receive capability to the CAN controller.

QUICK REFERENCE DATA

SYMBOL	PARAMETER	CONDITIONS	MIN.	MAX.	UNIT
V_{CC}	supply voltage		4.5	5.5	V
I_{CC}	supply current	standby mode	–	275	μ A
$1/t_{bit}$	maximum transmission speed	non-return-to-zero	1	–	Mbaud
V_{CAN}	CANH, CANL input/output voltage		–40	+40	V
V_{diff}	differential bus voltage		1.5	3.0	V
T_{amb}	operating ambient temperature		–40	+125	$^{\circ}$ C

ORDERING INFORMATION

TYPE NUMBER	PACKAGE		
	NAME	DESCRIPTION	CODE
PCA82C251	DIP8	plastic dual in-line package; 8 leads (300 mil)	SOT97-1
PCA82C251T	SO8	plastic small outline package; 8 leads body width 3.9 mm	SOT96-1

CAN transceiver for 24 V systems

PCA82C251

BLOCK DIAGRAM

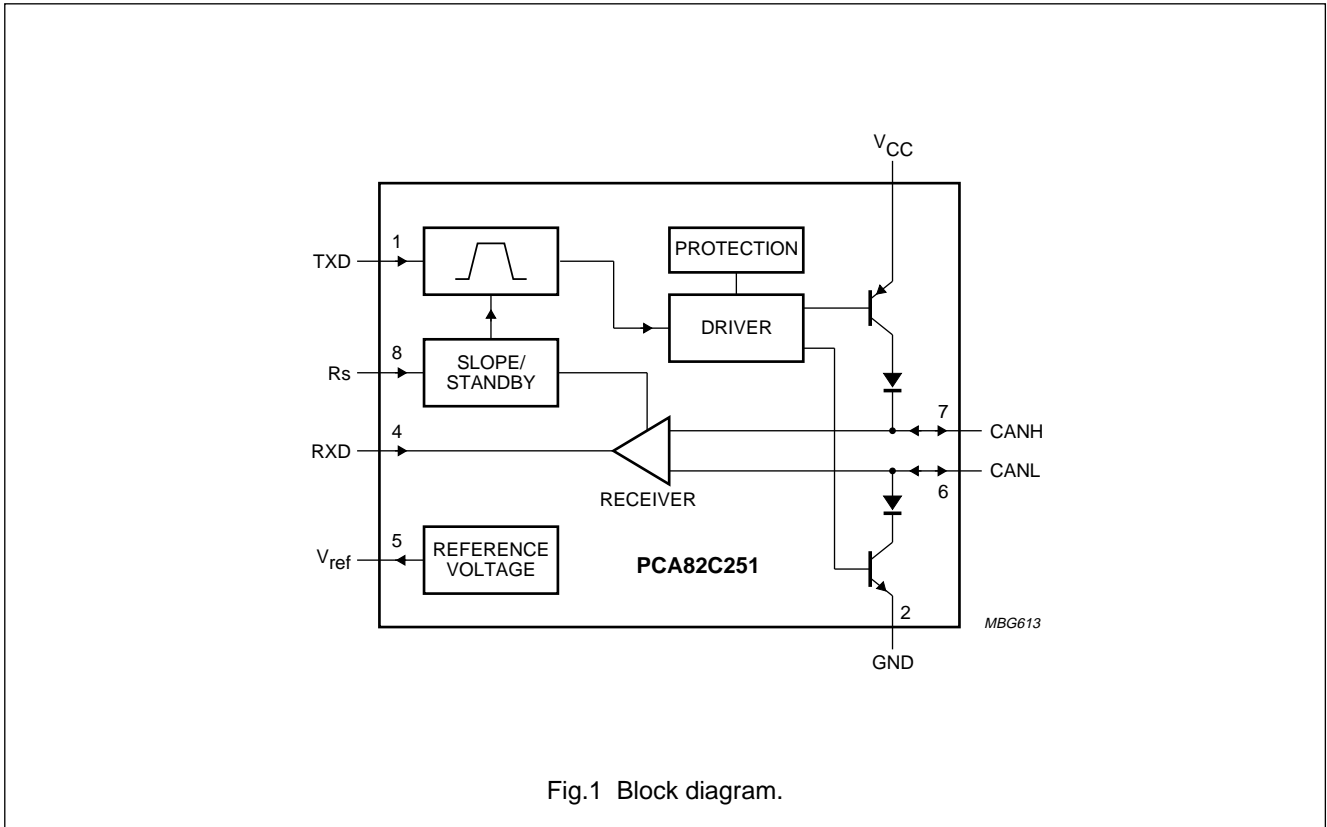

PINNING

SYMBOL	PIN	DESCRIPTION
TXD	1	transmit data input
GND	2	ground
V _{CC}	3	supply voltage
RXD	4	receive data output
V _{ref}	5	reference voltage output
CANL	6	LOW level CAN voltage input/output
CANH	7	HIGH level CAN voltage input/output
Rs	8	slope resistor input

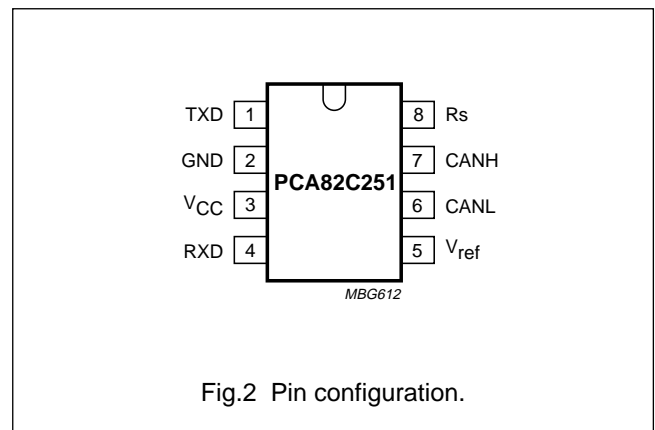

CAN transceiver for 24 V systems

PCA82C251

FUNCTIONAL DESCRIPTION

The PCA82C251 is the interface between the CAN protocol controller and the physical bus. It is primarily intended for applications up to 1 MBaud in trucks and buses. The device provides differential transmit capability to the bus and differential receive capability to the CAN controller. It is fully compatible with the "ISO 11898-24 V" standard.

A current limiting circuit protects the transmitter output stage against short-circuit to positive and negative battery voltage. Although the power dissipation is increased during this fault condition, this feature will prevent destruction of the transmitter output stage.

If the junction temperature exceeds a value of approximately 160 °C, the limiting current of both transmitter outputs is decreased. Because the transmitter is responsible for the major part of the power dissipation, this will result in a reduced power dissipation and hence a lower chip temperature. All other parts of the IC will remain operating. The thermal protection is particularly needed when a bus line is short-circuited.

The CANH and CANL lines are also protected against electrical transients which may occur in an automotive environment.

Pin 8 (Rs) allows three different modes of operation to be selected, high-speed, slope control or standby.

For high-speed operation, the transmitter output transistors are simply switched on and off as fast as possible. In this mode, no measures are taken to limit the rise and fall slope. Use of a shielded cable is recommended to avoid RFI problems. The high-speed mode is selected by connecting pin 8 to ground.

The slope control mode allows the use of an unshielded twisted pair or a parallel pair of wires as bus lines. To reduce RFI, the rise and fall slope should be limited. The rise and fall slope can be programmed with a resistor connected from pin 8 to ground. The slope is proportional to the current output at pin 8.

If a logic HIGH level is applied to pin 8, the circuit enters a low current standby mode. In this mode, the transmitter is switched off and the receiver is switched to a low current. If dominant bits are detected (differential bus voltage >0.9 V), RXD will be switched to a LOW level.

The microcontroller should react to this condition by switching the transceiver back to normal operation (via pin 8). Because the receiver is slower in standby mode, the first message will be lost at higher bit rates.

Table 1 Truth table of the CAN transceiver

V _{CC}	TXD	CANH	CANL	BUS STATE	RXD
4.5 to 5.5 V	0	HIGH	LOW	dominant	0
4.5 to 5.5 V	1 (or floating)	floating	floating	recessive	1 ⁽²⁾
4.5 < V _{CC} < 5.5 V	X ⁽¹⁾	floating if V _{Rs} > 0.75V _{CC}	floating if V _{Rs} > 0.75V _{CC}	floating	1 ⁽²⁾
0 < V _{CC} < 4.5 V	floating	floating	floating	floating	X ⁽¹⁾

Notes

- Where X = don't care.
- If another bus node is transmitting a dominant bit, then RXD is logic 0.

Table 2 Pin Rs summary

CONDITION FORCED AT PIN Rs	MODE	RESULTING VOLTAGE OR CURRENT AT PIN Rs
V _{Rs} > 0.75V _{CC}	standby	-I _{Rs} < 10 μA
10 μA < -I _{Rs} < 200 μA	slope control	0.4V _{CC} < V _{Rs} < 0.6V _{CC}
V _{Rs} < 0.3V _{CC}	high-speed	-I _{Rs} < 500 μA

CAN transceiver for 24 V systems

PCA82C251

LIMITING VALUES

In accordance with the Absolute Maximum Rating System (IEC 134). All voltages are referenced to pin 2; positive input current.

SYMBOL	PARAMETER	CONDITIONS	MIN.	MAX.	UNIT
V_{CC}	supply voltage		-0.3	+7.0	V
V_n	DC voltage at pins 1, 4, 5 and 8	$0\text{ V} < V_{CC} < 5.5\text{ V}$,	-0.3	$V_{CC} + 0.3$	V
$V_{(DC)}$	DC voltage CANL (pin 6)	TXD HIGH or floating	-40	+40	V
		note 1; no time limit	-40	+40	V
	CANH (pin 7)	note 2; no time limit	-40	+40	V
		no time limit	-40	+40	V
V_{tr}	transient voltage on pins 6 and 7	see Fig.8	-200	+200	V
T_{stg}	storage temperature		-55	+150	°C
T_{amb}	operating ambient temperature		-40	+125	°C
T_{vj}	virtual junction temperature	note 3	-40	+150	°C
V_{esd}	electrostatic discharge	note 4	-2500	+2500	V
		note 5	-250	+250	V

Notes

1. TXD is LOW. Short circuit protection provided for slew rates up to $5\text{ V}/\mu\text{s}$ for voltages above +30 V.
2. Short circuit applied when TXD is HIGH, followed by TXD switched to LOW.
3. In accordance with "IEC 747-1".
An alternative definition of virtual junction temperature T_{vj} is: $T_{vj} = T_{amb} + P_d \times R_{th\ vj-amb}$,
where $R_{th\ vj-amb}$ is a fixed value to be used for the calculation of T_{vj} .
The rating for T_{vj} limits the allowable combinations of power dissipation (P_d) and ambient temperature (T_{amb}).
4. Classification A: human body model; C = 100 pF; R = 1500 Ω ; V = $\pm 2500\text{ V}$.
5. Classification B: machine model; C = 200 pF; R = 0 Ω ; V = $\pm 250\text{ V}$.

QUALITY SPECIFICATION

Quality specification "SNW-FQ-611 part E" is applicable and can be found in the "Quality reference handbook" (ordering number 9397 750 00192).

THERMAL CHARACTERISTICS

SYMBOL	PARAMETER	VALUE	UNIT
$R_{th\ j-a}$	thermal resistance from junction to ambient in free air		
	SO8	160	K/W
	DIP8	100	K/W

CAN transceiver for 24 V systems

PCA82C251

CHARACTERISTICS

$V_{CC} = 4.5$ to 5.5 V; $T_{amb} = -40$ to $+125$ °C; $R_L = 60$ Ω; $I_b > -10$ μA; unless otherwise specified.

All voltages referenced to ground (pin 2); positive input current; all parameters are guaranteed over the ambient temperature range by design, but only 100% tested at $+25$ °C.

SYMBOL	PARAMETER	CONDITIONS	MIN.	TYP.	MAX.	UNIT
Supply						
I_3	supply current	dominant; $V_1 = 1$ V; $V_{CC} < 5.1$ V	–	–	78	mA
		dominant; $V_1 = 1$ V; $V_{CC} < 5.25$ V	–	–	80	mA
		dominant; $V_1 = 1$ V; $V_{CC} < 5.5$ V	–	–	85	mA
		recessive; $V_1 = 4$ V; $R_8 = 47$ kΩ	–	–	10	mA
		standby; note 1	–	–	275	μA
DC-bus transmitter						
V_{IH}	HIGH level input voltage	output recessive	$0.7V_{CC}$	–	$V_{CC} + 0.3$	V
V_{IL}	LOW level input voltage	output dominant	–0.3	–	$0.3V_{CC}$	V
I_{IH}	HIGH level input current	$V_1 = 4$ V	–200	–	+30	μA
I_{IL}	LOW level input voltage	$V_1 = 1$ V	100	–	600	μA
$V_{6,7}$	recessive bus voltage	$V_1 = 4$ V; no load	2.0	–	3.0	V
I_{LO}	off-state output leakage current	-2 V < (V_6, V_7) < 7 V	–2	–	+2	mA
		-5 V < (V_6, V_7) < 36 V	–10	–	+10	mA
V_7	CANH output voltage	$V_1 = 1$ V; $V_{CC} = 4.75$ to 5.5 V	3.0	–	4.5	V
		$V_1 = 1$ V; $V_{CC} = 4.5$ to 4.75 V	2.75	–	4.5	V
V_6	CANL output voltage	$V_1 = 1$ V	0.5	–	2.0	V
$\Delta V_{6,7}$	difference between output voltage at pins 6 and 7	$V_1 = 1$ V	1.5	–	3.0	V
		$V_1 = 1$ V; $R_L = 45$ Ω	1.5	–	–	V
		$V_1 = 4$ V; no load	–500	–	+50	mV
I_{sc7}	short-circuit CANH current	$V_7 = -5$ V	–	–	–200	mA
		$V_7 = -36$ V	–	–100	–	mA
I_{sc6}	short-circuit CANL current	$V_6 = 36$ V	–	–	200	mA
DC bus receiver [$V_1 = 4$ V; pins 6 and 7 externally driven; -2 V < (V_6, V_7) < 7 V; unless otherwise specified]						
$V_{diff(r)}$	differential input voltage (recessive)	note 2	–1.0	–	+0.5	V
		note 2; -7 V < (V_6, V_7) < 12 V	–1.0	–	+0.4	V
$V_{diff(d)}$	differential input voltage (dominant)		0.9	–	5.0	V
		-7 V < (V_6, V_7) < 12 V	1.0	–	5.0	V
		standby mode	0.97	–	5.0	V
		standby mode; $V_{CC} = 4.5$ to 5.25 V	0.91	–	5.0	V

CAN transceiver for 24 V systems

PCA82C251

SYMBOL	PARAMETER	CONDITIONS	MIN.	TYP.	MAX.	UNIT
$V_{diff(hys)}$	differential input hysteresis	see Fig.5	–	150	–	mV
V_{OH}	HIGH level output voltage (pin 4)	$I_4 = -100 \mu A$	$0.8V_{CC}$	–	V_{CC}	V
V_{OL}	LOW level output voltage (pin 4)	$I_4 = 1 \text{ mA}$	0	–	$0.2V_{CC}$	V
		$I_4 = 10 \text{ mA}$	0	–	1.5	V
R_i	CANH, CANL input resistance		5	–	25	k Ω
R_{diff}	differential input resistance		20	–	100	k Ω
Reference output						
V_{ref}	reference output voltage	$V_8 = 1 \text{ V}; I_5 < 50 \mu A$	$0.45V_{CC}$	–	$0.55V_{CC}$	V
		$V_8 = 4 \text{ V}; I_5 < 5 \mu A$	$0.4V_{CC}$	–	$0.6V_{CC}$	V
Timing ($R_L = 60 \Omega$; $C_L = 100 \text{ pF}$; see Figs 3 and 4)						
t_{bit}	minimum bit time	$R_8 = 0 \Omega$	–	–	1	μs
t_{onTXD}	delay TXD to bus active	$R_8 = 0 \Omega$	–	–	50	ns
t_{offTXD}	delay TXD to bus inactive	$R_8 = 0 \Omega$	–	40	80	ns
t_{onRXD}	delay TXD to receiver active	$R_8 = 0 \Omega$	–	55	120	ns
t_{offRXD}	delay TXD to receiver inactive	$R_8 = 0 \Omega$; $T_{amb} < +85 \text{ }^\circ\text{C}$; $V_{CC} = 4.5 \text{ to } 5.1 \text{ V}$	–	80	150	ns
		$R_8 = 0 \Omega$; $V_{CC} = 4.5 \text{ to } 5.1 \text{ V}$	–	80	170	ns
		$R_8 = 0 \Omega$; $T_{amb} < +85 \text{ }^\circ\text{C}$	–	90	170	ns
		$R_8 = 0 \Omega$	–	90	190	ns
		$R_8 = 47 \text{ k}\Omega$	–	290	400	ns
t_{onRXD}	delay TXD to receiver active	$R_8 = 47 \text{ k}\Omega$	–	440	550	ns
$ SR $	CANH, CANL slew rate	$R_8 = 47 \text{ k}\Omega$	–	7	–	V/ μs
t_{WAKE}	wake-up time from standby (via pin 8)	see Fig.6	–	–	20	μs
t_{dRXDL}	bus dominant to RXD LOW	$V_8 = 4 \text{ V}$; see Fig.7	–	–	3	μs
Standby/slope control (pin 8)						
V_{stb}	input voltage for standby mode		$0.75V_{CC}$	–	–	V
I_{slope}	slope control mode current		–10	–	–200	μA
V_{slope}	slope control mode voltage		$0.4V_{CC}$	–	$0.6V_{CC}$	V

Notes

- $I_1 = I_4 = I_5 = 0 \text{ mA}$; $0 \text{ V} < V_6 < V_{CC}$; $0 \text{ V} < V_7 < V_{CC}$; $V_8 = V_{CC}$; $T_{amb} < 90 \text{ }^\circ\text{C}$.
- This is valid for the receiver in all modes, high-speed, slope control and standby.

CAN transceiver for 24 V systems

PCA82C251

TEST AND APPLICATION INFORMATION

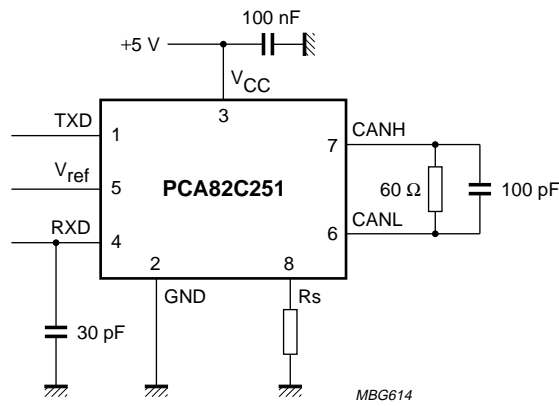

Fig.3 Test circuit for dynamic characteristics.

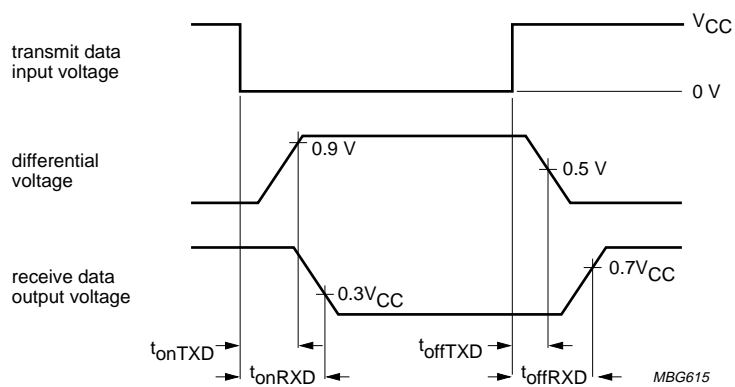

Fig.4 Timing diagram for dynamic characteristics.

CAN transceiver for 24 V systems

PCA82C251

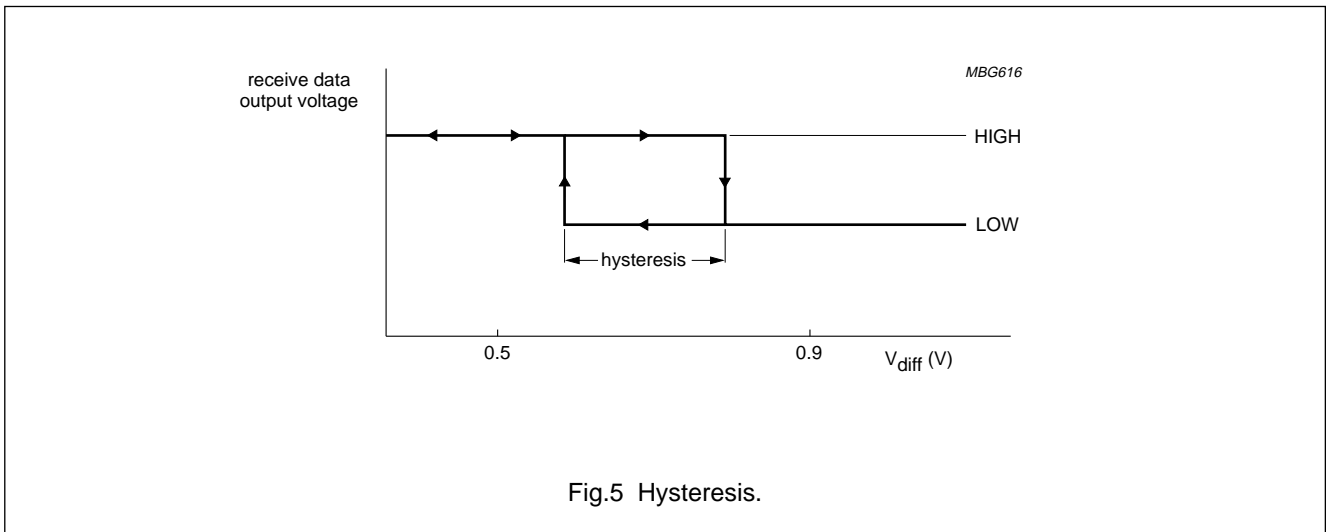

Fig.5 Hysteresis.

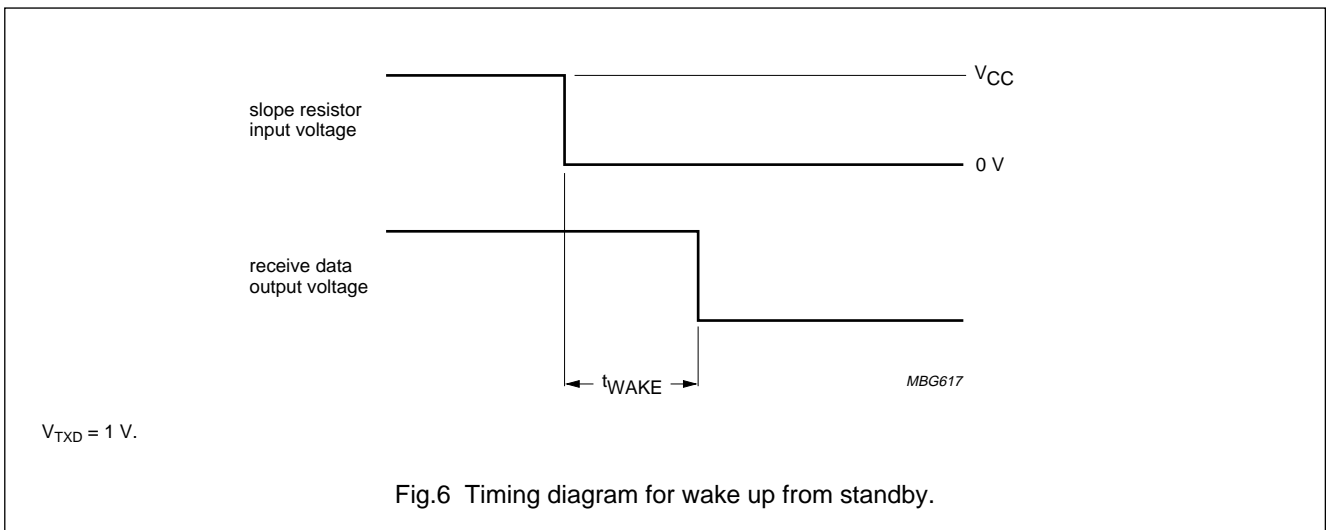

Fig.6 Timing diagram for wake up from standby.

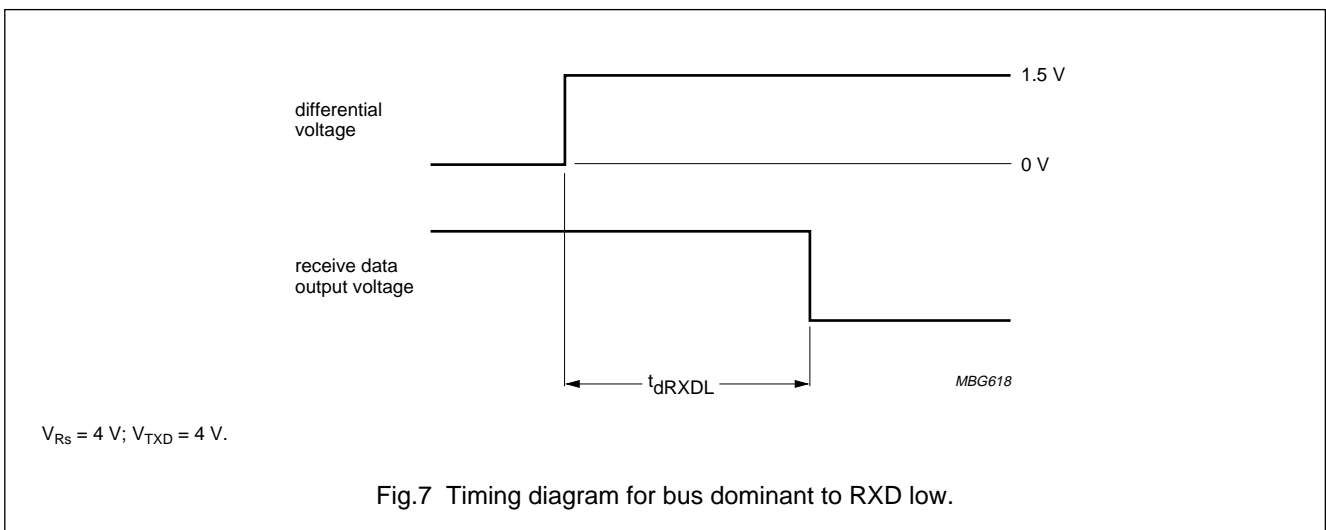
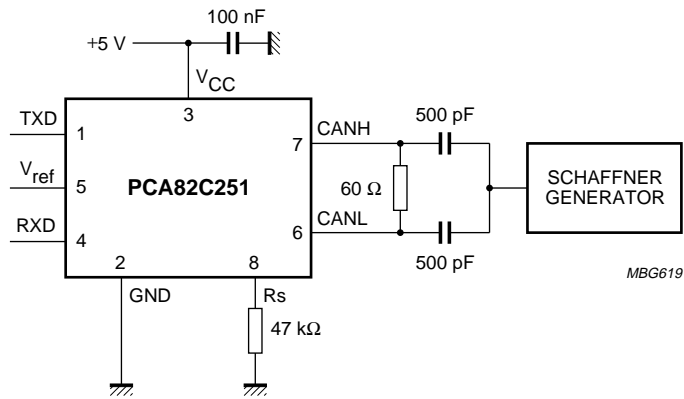

Fig.7 Timing diagram for bus dominant to RXD low.

CAN transceiver for 24 V systems

PCA82C251



The wave forms of the applied transients shall be in accordance with "ISO 7637 part 1", test pulses 1, 2, 3a and 3b.

Fig.8 Test circuit for automotive transients.

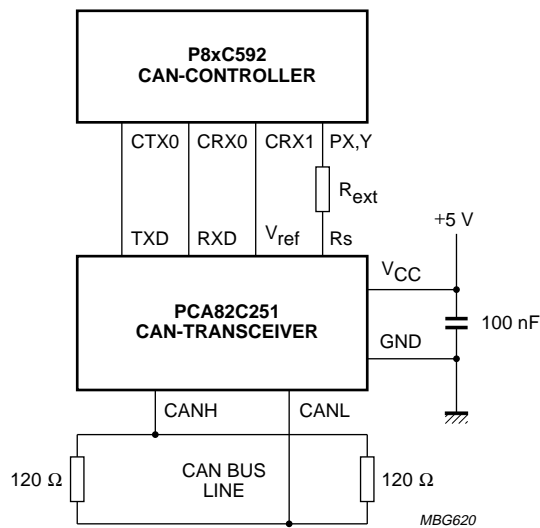

- (1) The output control register of the P8xC592 should be programmed to 1AH (push-pull operation, dominant = LOW).
- (2) If no slope control is desired; $R_{ext} = 0$.

Fig.9 Application of the PCA82C251 CAN Transceiver.

CAN transceiver for 24 V systems

PCA82C251

PACKAGE OUTLINES

DIP8: plastic dual in-line package; 8 leads (300 mil)

SOT97-1

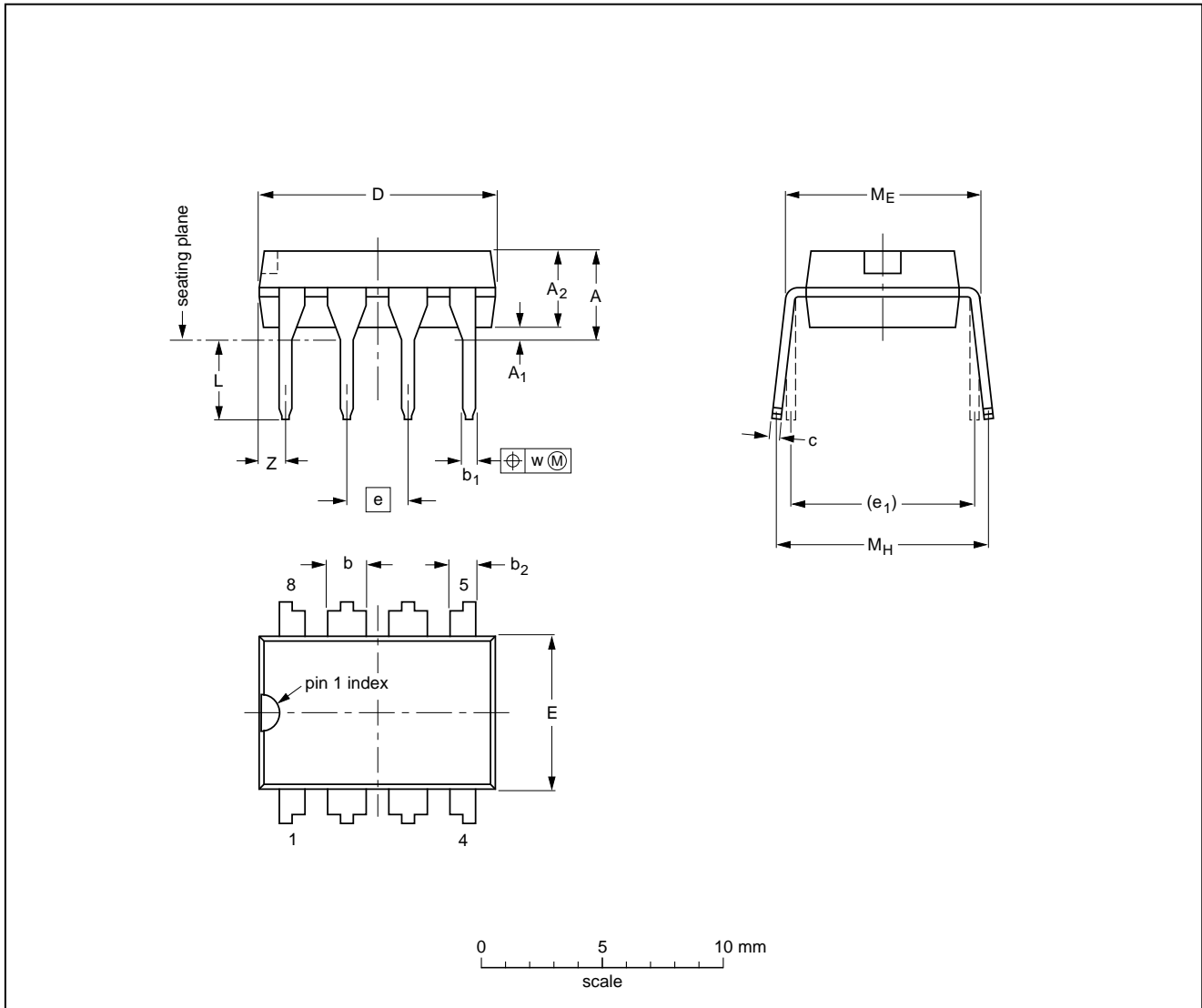

DIMENSIONS (inch dimensions are derived from the original mm dimensions)

UNIT	A max.	A ₁ min.	A ₂ max.	b	b ₁	b ₂	c	D ⁽¹⁾	E ⁽¹⁾	e	e ₁	L	M _E	M _H	w	Z ⁽¹⁾ max.
mm	4.2	0.51	3.2	1.73 1.14	0.53 0.38	1.07 0.89	0.36 0.23	9.8 9.2	6.48 6.20	2.54	7.62	3.60 3.05	8.25 7.80	10.0 8.3	0.254	1.15
inches	0.17	0.020	0.13	0.068 0.045	0.021 0.015	0.042 0.035	0.014 0.009	0.39 0.36	0.26 0.24	0.10	0.30	0.14 0.12	0.32 0.31	0.39 0.33	0.01	0.045

Note

1. Plastic or metal protrusions of 0.25 mm maximum per side are not included.

OUTLINE VERSION	REFERENCES				EUROPEAN PROJECTION	ISSUE DATE
	IEC	JEDEC	EIAJ			
SOT97-1	050G01	MO-001AN				92-11-17 95-02-04

CAN transceiver for 24 V systems

PCA82C251

SO8: plastic small outline package; 8 leads; body width 3.9 mm

SOT96-1

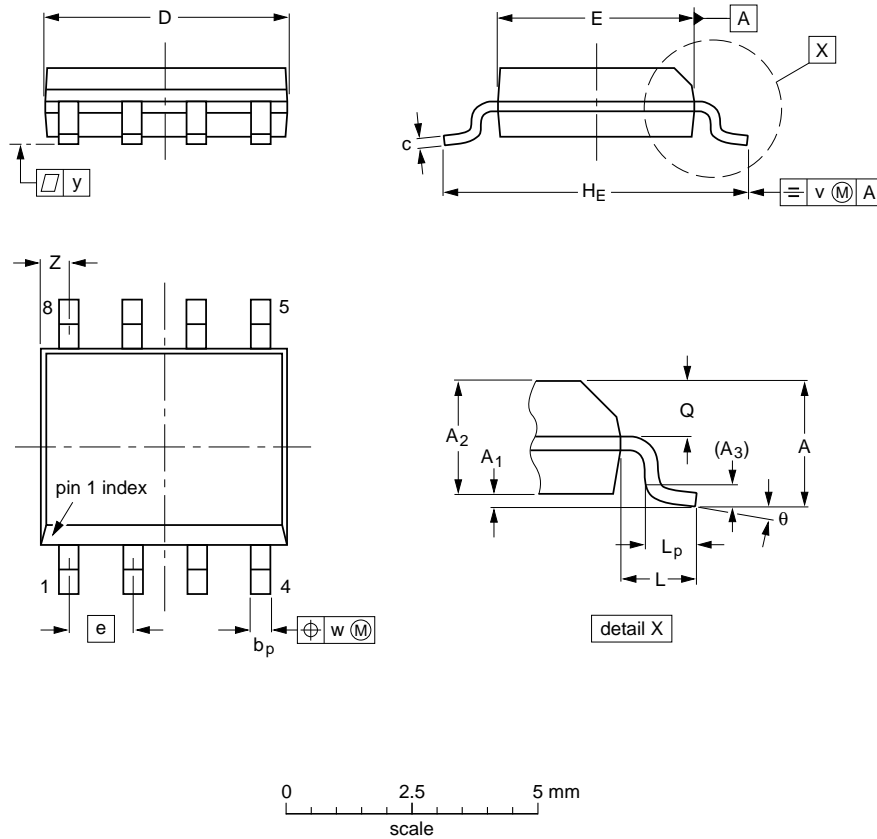

DIMENSIONS (inch dimensions are derived from the original mm dimensions)

UNIT	A max.	A ₁	A ₂	A ₃	b _p	c	D ⁽¹⁾	E ⁽²⁾	e	H _E	L	L _p	Q	v	w	y	Z ⁽¹⁾	θ
mm	1.75	0.25 0.10	1.45 1.25	0.25	0.49 0.36	0.25 0.19	5.0 4.8	4.0 3.8	1.27	6.2 5.8	1.05	1.0 0.4	0.7 0.6	0.25	0.25	0.1	0.7 0.3	8° 0°
inches	0.069	0.0098 0.0039	0.057 0.049	0.01	0.019 0.014	0.0098 0.0075	0.20 0.19	0.16 0.15	0.050	0.24 0.23	0.041	0.039 0.016	0.028 0.024	0.01	0.01	0.004	0.028 0.012	

Notes

1. Plastic or metal protrusions of 0.15 mm maximum per side are not included.
2. Plastic or metal protrusions of 0.25 mm maximum per side are not included.

OUTLINE VERSION	REFERENCES				EUROPEAN PROJECTION	ISSUE DATE
	IEC	JEDEC	EIAJ			
SOT96-1	076E03S	MS-012AA				92-11-17 95-02-04

CAN transceiver for 24 V systems

PCA82C251

SOLDERING

Introduction

There is no soldering method that is ideal for all IC packages. Wave soldering is often preferred when through-hole and surface mounted components are mixed on one printed-circuit board. However, wave soldering is not always suitable for surface mounted ICs, or for printed-circuits with high population densities. In these situations reflow soldering is often used.

This text gives a very brief insight to a complex technology. A more in-depth account of soldering ICs can be found in our "IC Package Databook" (order code 9398 652 90011).

DIP

SOLDERING BY DIPPING OR BY WAVE

The maximum permissible temperature of the solder is 260 °C; solder at this temperature must not be in contact with the joint for more than 5 seconds. The total contact time of successive solder waves must not exceed 5 seconds.

The device may be mounted up to the seating plane, but the temperature of the plastic body must not exceed the specified maximum storage temperature ($T_{stg\ max}$). If the printed-circuit board has been pre-heated, forced cooling may be necessary immediately after soldering to keep the temperature within the permissible limit.

REPAIRING SOLDERED JOINTS

Apply a low voltage soldering iron (less than 24 V) to the lead(s) of the package, below the seating plane or not more than 2 mm above it. If the temperature of the soldering iron bit is less than 300 °C it may remain in contact for up to 10 seconds. If the bit temperature is between 300 and 400 °C, contact may be up to 5 seconds.

SO

REFLOW SOLDERING

Reflow soldering techniques are suitable for all SO packages.

Reflow soldering requires solder paste (a suspension of fine solder particles, flux and binding agent) to be applied to the printed-circuit board by screen printing, stencilling or pressure-syringe dispensing before package placement.

Several techniques exist for reflowing; for example, thermal conduction by heated belt. Dwell times vary between 50 and 300 seconds depending on heating method. Typical reflow temperatures range from 215 to 250 °C.

Preheating is necessary to dry the paste and evaporate the binding agent. Preheating duration: 45 minutes at 45 °C.

WAVE SOLDERING

Wave soldering techniques can be used for all SO packages if the following conditions are observed:

- A double-wave (a turbulent wave with high upward pressure followed by a smooth laminar wave) soldering technique should be used.
- The longitudinal axis of the package footprint must be parallel to the solder flow.
- The package footprint must incorporate solder thieves at the downstream end.

During placement and before soldering, the package must be fixed with a droplet of adhesive. The adhesive can be applied by screen printing, pin transfer or syringe dispensing. The package can be soldered after the adhesive is cured.

Maximum permissible solder temperature is 260 °C, and maximum duration of package immersion in solder is 10 seconds, if cooled to less than 150 °C within 6 seconds. Typical dwell time is 4 seconds at 250 °C.

A mildly-activated flux will eliminate the need for removal of corrosive residues in most applications.

REPAIRING SOLDERED JOINTS

Fix the component by first soldering two diagonally-opposite end leads. Use only a low voltage soldering iron (less than 24 V) applied to the flat part of the lead. Contact time must be limited to 10 seconds at up to 300 °C. When using a dedicated tool, all other leads can be soldered in one operation within 2 to 5 seconds between 270 and 320 °C.

CAN transceiver for 24 V systems

PCA82C251

DEFINITIONS

Data sheet status	
Objective specification	This data sheet contains target or goal specifications for product development.
Preliminary specification	This data sheet contains preliminary data; supplementary data may be published later.
Product specification	This data sheet contains final product specifications.
Limiting values	
Limiting values given are in accordance with the Absolute Maximum Rating System (IEC 134). Stress above one or more of the limiting values may cause permanent damage to the device. These are stress ratings only and operation of the device at these or at any other conditions above those given in the Characteristics sections of the specification is not implied. Exposure to limiting values for extended periods may affect device reliability.	
Application information	
Where application information is given, it is advisory and does not form part of the specification.	

LIFE SUPPORT APPLICATIONS

These products are not designed for use in life support appliances, devices, or systems where malfunction of these products can reasonably be expected to result in personal injury. Philips customers using or selling these products for use in such applications do so at their own risk and agree to fully indemnify Philips for any damages resulting from such improper use or sale.

CAN transceiver for 24 V systems

PCA82C251

NOTES

Philips Semiconductors – a worldwide company

Argentina: see South America

Australia: 34 Waterloo Road, NORTH RYDE, NSW 2113,
Tel. +61 2 9805 4455, Fax. +61 2 9805 4466

Austria: Computerstr. 6, A-1101 WIEN, P.O. Box 213,
Tel. +43 1 60 101, Fax. +43 1 60 101 1210

Belarus: Hotel Minsk Business Center, Bld. 3, r. 1211, Volodarski Str. 6,
220050 MINSK, Tel. +375 172 200 733, Fax. +375 172 200 773

Belgium: see The Netherlands

Brazil: see South America

Bulgaria: Philips Bulgaria Ltd., Energoproject, 15th floor,
51 James Bourchier Blvd., 1407 SOFIA,
Tel. +359 2 689 211, Fax. +359 2 689 102

Canada: PHILIPS SEMICONDUCTORS/COMPONENTS,
Tel. +1 800 234 7381

China/Hong Kong: 501 Hong Kong Industrial Technology Centre,
72 Tat Chee Avenue, Kowloon Tong, HONG KONG,
Tel. +852 2319 7888, Fax. +852 2319 7700

Colombia: see South America

Czech Republic: see Austria

Denmark: Prags Boulevard 80, PB 1919, DK-2300 COPENHAGEN S,
Tel. +45 32 88 2636, Fax. +45 31 57 1949

Finland: Sinikalliontie 3, FIN-02630 ESPOO,
Tel. +358 9 615800, Fax. +358 9 61580/xxx

France: 4 Rue du Port-aux-Vins, BP317, 92156 SURESNES Cedex,
Tel. +33 1 40 99 6161, Fax. +33 1 40 99 6427

Germany: Hammerbrookstraße 69, D-20097 HAMBURG,
Tel. +49 40 23 53 60, Fax. +49 40 23 536 300

Greece: No. 15, 25th March Street, GR 17778 TAVROS/ATHENS,
Tel. +30 1 4894 339/239, Fax. +30 1 4814 240

Hungary: see Austria

India: Philips INDIA Ltd, Shivsagar Estate, A Block, Dr. Annie Besant Rd.
Worli, MUMBAI 400 018, Tel. +91 22 4938 541, Fax. +91 22 4938 722

Indonesia: see Singapore

Ireland: Newstead, Clonskeagh, DUBLIN 14,
Tel. +353 1 7640 000, Fax. +353 1 7640 200

Israel: RAPAC Electronics, 7 Kehilat Saloniki St, TEL AVIV 61180,
Tel. +972 3 645 0444, Fax. +972 3 649 1007

Italy: PHILIPS SEMICONDUCTORS, Piazza IV Novembre 3,
20124 MILANO, Tel. +39 2 6752 2531, Fax. +39 2 6752 2557

Japan: Philips Bldg 13-37, Kohnan 2-chome, Minato-ku, TOKYO 108,
Tel. +81 3 3740 5130, Fax. +81 3 3740 5077

Korea: Philips House, 260-199 Itaewon-dong, Yongsan-ku, SEOUL,
Tel. +82 2 709 1412, Fax. +82 2 709 1415

Malaysia: No. 76 Jalan Universiti, 46200 PETALING JAYA, SELANGOR,
Tel. +60 3 750 5214, Fax. +60 3 757 4880

Mexico: 5900 Gateway East, Suite 200, EL PASO, TEXAS 79905,
Tel. +9-5 800 234 7381

Middle East: see Italy

Netherlands: Postbus 90050, 5600 PB EINDHOVEN, Bldg. VB,
Tel. +31 40 27 82785, Fax. +31 40 27 88399

New Zealand: 2 Wagener Place, C.P.O. Box 1041, AUCKLAND,
Tel. +64 9 849 4160, Fax. +64 9 849 7811

Norway: Box 1, Manglerud 0612, OSLO,
Tel. +47 22 74 8000, Fax. +47 22 74 8341

Philippines: Philips Semiconductors Philippines Inc.,
106 Valero St. Salcedo Village, P.O. Box 2108 MCC, MAKATI,
Metro MANILA, Tel. +63 2 816 6380, Fax. +63 2 817 3474

Poland: Ul. Lukiska 10, PL 04-123 WARSZAWA,
Tel. +48 22 612 2831, Fax. +48 22 612 2327

Portugal: see Spain

Romania: see Italy

Russia: Philips Russia, Ul. Usatcheva 35A, 119048 MOSCOW,
Tel. +7 095 755 6918, Fax. +7 095 755 6919

Singapore: Lorong 1, Toa Payoh, SINGAPORE 1231,
Tel. +65 350 2538, Fax. +65 251 6500

Slovakia: see Austria

Slovenia: see Italy

South Africa: S.A. PHILIPS Pty Ltd., 195-215 Main Road Martindale,
2092 JOHANNESBURG, P.O. Box 7430 Johannesburg 2000,
Tel. +27 11 470 5911, Fax. +27 11 470 5494

South America: Rua do Rocio 220, 5th floor, Suite 51,
04552-903 São Paulo, SÃO PAULO - SP, Brazil,
Tel. +55 11 821 2333, Fax. +55 11 829 1849

Spain: Balmes 22, 08007 BARCELONA,
Tel. +34 3 301 6312, Fax. +34 3 301 4107

Sweden: Kottbygatan 7, Akalla, S-16485 STOCKHOLM,
Tel. +46 8 632 2000, Fax. +46 8 632 2745

Switzerland: Allmendstrasse 140, CH-8027 ZÜRICH,
Tel. +41 1 488 2686, Fax. +41 1 481 7730

Taiwan: Philips Semiconductors, 6F, No. 96, Chien Kuo N. Rd., Sec. 1,
TAIPEI, Taiwan Tel. +886 2 2134 2870, Fax. +886 2 2134 2874

Thailand: PHILIPS ELECTRONICS (THAILAND) Ltd.,
209/2 Sanpavuth-Bangna Road Prakanong, BANGKOK 10260,
Tel. +66 2 745 4090, Fax. +66 2 398 0793

Turkey: Talatpasa Cad. No. 5, 80640 GÜLTEPE/ISTANBUL,
Tel. +90 212 279 2770, Fax. +90 212 282 6707

Ukraine: PHILIPS UKRAINE, 4 Patrice Lumumba str., Building B, Floor 7,
252042 KIEV, Tel. +380 44 264 2776, Fax. +380 44 268 0461

United Kingdom: Philips Semiconductors Ltd., 276 Bath Road, Hayes,
MIDDLESEX UB3 5BX, Tel. +44 181 730 5000, Fax. +44 181 754 8421

United States: 811 East Arques Avenue, SUNNYVALE, CA 94088-3409,
Tel. +1 800 234 7381

Uruguay: see South America

Vietnam: see Singapore

Yugoslavia: PHILIPS, Trg N. Pasica 5/v, 11000 BEOGRAD,
Tel. +381 11 625 344, Fax. +381 11 635 777

For all other countries apply to: Philips Semiconductors, Marketing & Sales Communications,
Building BE-p, P.O. Box 218, 5600 MD EINDHOVEN, The Netherlands, Fax. +31 40 27 24825

Internet: <http://www.semiconductors.philips.com>

© Philips Electronics N.V. 1997

SCA53

All rights are reserved. Reproduction in whole or in part is prohibited without the prior written consent of the copyright owner.

The information presented in this document does not form part of any quotation or contract, is believed to be accurate and reliable and may be changed without notice. No liability will be accepted by the publisher for any consequence of its use. Publication thereof does not convey nor imply any license under patent- or other industrial or intellectual property rights.

Printed in The Netherlands

617021/00/02/pp16

Date of release: 1997 Mar 14

Document order number: 9397 750 01598

Let's make things better.

**Philips
Semiconductors**



PHILIPS