

# DC Output Solid State Relay

# PCS32 DC Output

Horizontal



Vertical



## FEATURES

- Small Dimension for High Packing Density PCB Assembly or Socket Mount
- 2,500 VRMS Opto-Isolation Between Input and Output
- TTL and CMOS compatible
- Pin Compatible with Standard Package EMR
- RoHS Compliant



## INPUT PARAMETERS (Ta = 25°C)

Control Voltage Range	5D	4 - 6 VDC
	12D	9.6 - 14.4 VDC
	24D	19.2 - 28.8 VDC
	48D	38.4 - 57.6 VDC
	60D	48 - 72 VDC
Must Turn-On Voltage	5D	4 VDC
	12D	9.6 VDC
	24D	19.2 VDC
	48D	38.4 VDC
	60D	48 VDC
Must Turn-Off Voltage	5D	1 VDC
	12D	3 VDC
	24D	10 VDC
	48D	10 VDC
	60D	20 VDC
Max. Input Current	25 mA	
Max. Reverse Protection Voltage	5D	-6 VDC
	12D	-14.4 VDC
	24D	-28.8 VDC
	48D	-57.6 VDC
	60D	-72 VDC

## OUTPUT PARAMETERS (Ta = 25°C)

Load Voltage Range	24D	0 - 28.8 VDC
	48D	0 - 57.6 VDC
Max. Transient Voltage	24D	33 VDC
	48D	58 VDC
Load Current Range	24D3	0.02 - 3 A
	24D4	0.02 - 4 A
	24D5	0.02 - 5 A
	48D3	0.02 - 3 A
Max. Surge Current (10 ms)	24D3	48 Apk
	24D4	48 Apk
	24D5	60 Apk
48D3	30 Apk	
	Max. Off-State Leakage Current	100 uA
Max. On-State Voltage Drop	24D3	0.2 VDC
	24D4	0.35 VDC
	24D5	0.2 VDC
	48D3	0.35 VDC
Max. Turn-On Time	50 us	
Max. Turn-Off Time	300 us	

## ORDERING INFORMATION

Example:	PCS32 Output	-12D	-24D	-2	Z
Model:	PCS32 DC Output				
Control Voltage:	5D: 5 VDC; 12D: 12 VDC; 24D: 24 VDC; 48D: 48 VDC; 60D: 60 VDC				
Load Voltage:	24D: 24 VDC; 48A: 48 VDC				
Load Current:	3: 3 A (Vertical); 4: 4 A (Vertical); 5: 5 A (Horizontal)				
RC Snubber type:	Nil: Without RC Snubber				
Mounting Mode:	Nil: Vertical (PC Pins In Line); H: Horizontal (PC Pins Dual In Line)				

Vertical Box Quantity: 2000; Inner Box: 100, Horizontal Box Quantity: 500; Inner Box: 50

**PRECAUTIONS**

1. Soldering must be completed within 10s at 260 or less or within 5s at 350 or less.
2. The SSR case serves to dissipate heat. Install the relays so that they are adequately ventilated. If poor ventilation is unavoidable, the load current must be reduced. Please refer to the curve of Max. Load current Vs. Ambient Temperature.
3. If the output transient voltage exceeds the nominal value, a varistor should be mounted on the SSR output terminal in parallel to prevent the relay being breakdown. 240VAC output relays are suggested to use 470 VDC varistors.
4. Please do not use the relay beyond the descriptions in the datasheet.

**CHARACTERISTICS**

Dielectric Strength	2,500 VAC, 1 min. (Input yo Output)
Insulation Resistance	1,000 MΩ at 500 VDC
Max. Capacitance	5 pF (Input to Output)
Vibration Resistance	10 Hz - 55 Hz 1.5 mm DA
Shock Resistance	Acceleration 980 m/s <sup>2</sup> , Continuous Surge 6 ms

Operating Temperature	- 30°C to 80°C
Storage Temperature	- 30°C to 100°C
Relative Humidity	45% - 85%
Weight	11 g (Horizontal), 4g (Vertical)

**DIMENSIONS (mm)**

**Outline Dimensions**

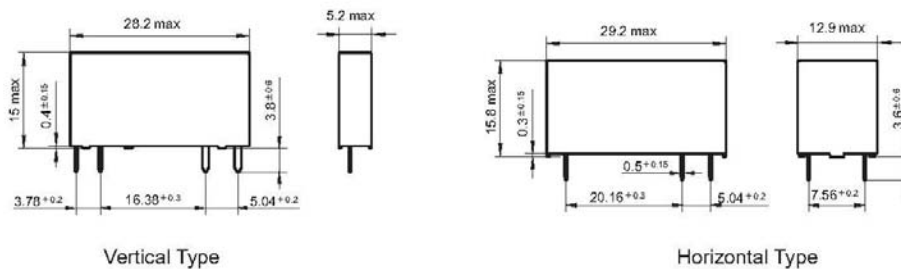

**PCB and Socket Layout**

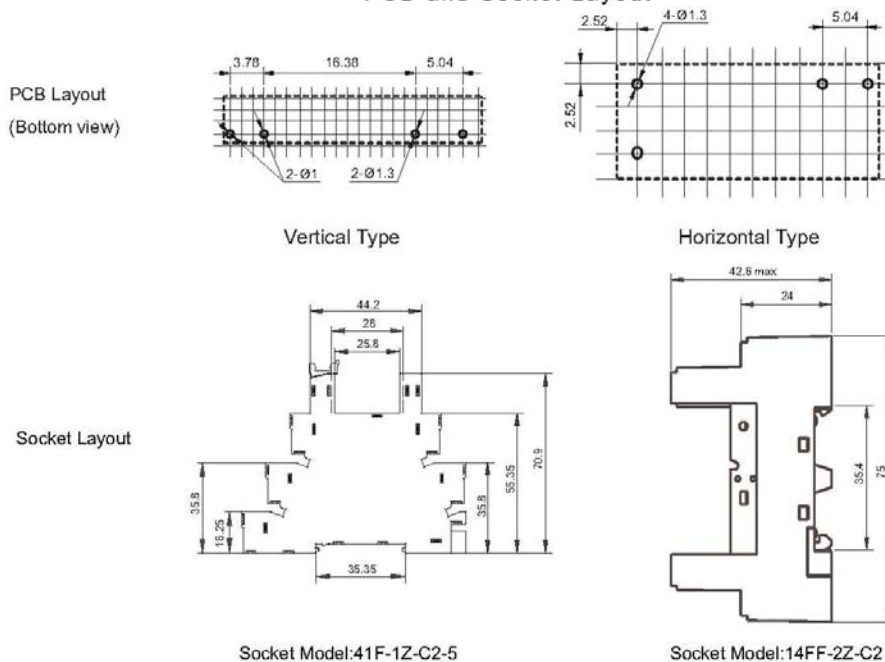

3220 Commander Drive, Suite 102 Carrollton, TX 75006

Sales: (972) 713-6272

(888) 997-3933

Fax: (972)735-0964

www.PickerComponents.com

e-mail: sales@pickercomponents.com

DIMENSIONS (mm) - Continued

Wiring Diagram

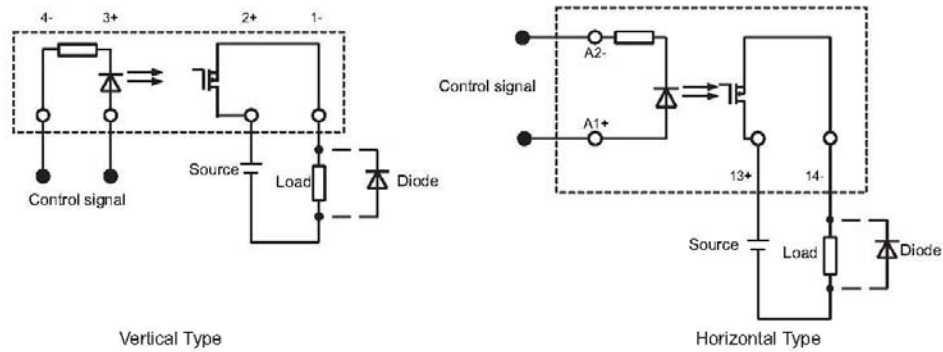

CHARACTERISTIC CURVES

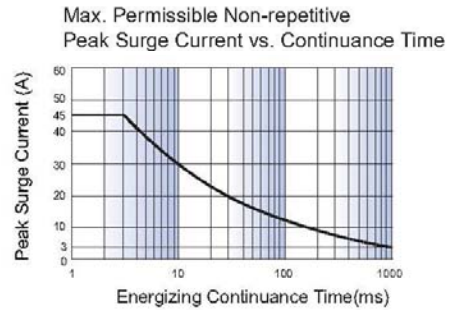
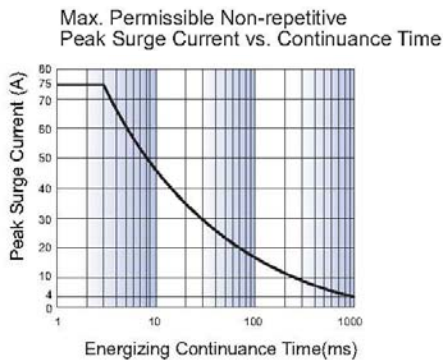
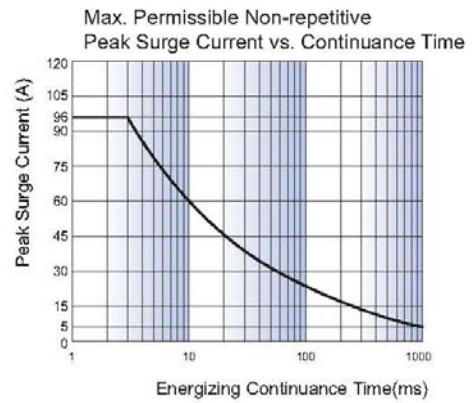
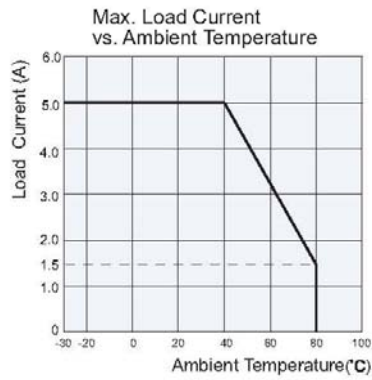
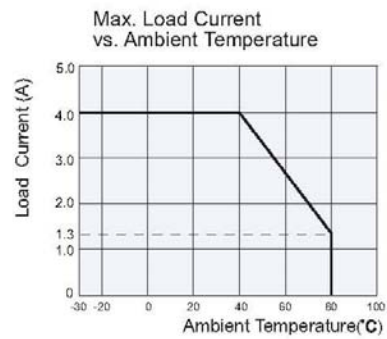
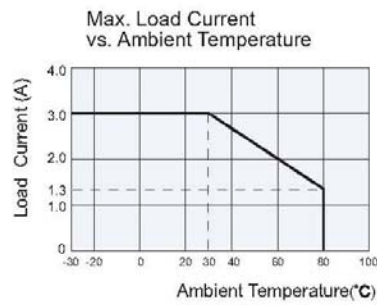

3220 Commander Drive, Suite 102 Carrollton, TX 75006  
 Sales: (972) 713-6272 (888) 997-3933 Fax: (972) 735-0964

www.PickerComponents.com  
 e-mail: sales@pickercomponents.com