

N-Channel Enhancement-Mode Power Field-Effect Transistor Chip

10 A, 120 V, 0.3 Ω

Features:

- **Contact metallization:**
Gate and source-aluminum
Drain-tri-metal (Al-Ti-Ni)
- **Assembly recommendations:**
Gate and source-10-mil aluminum wire
Drain-mounted with 95/5 lead-tin solder
- **Die Number-09530**
- **Device types that are derived from PCF10N12L-**
RFM10N12L RFP10N12L
RFM10N15L RFP10N15L

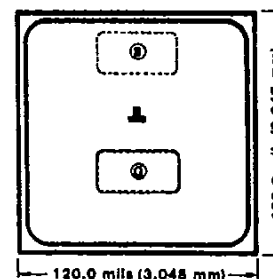

ATTACH AREAS: 02C8-38990
 ② Source } 0.020" x 0.040" (0.508 mm x 1.016 mm)
 ① Gate }
 ③ Back Side - Drain
 DIE THICKNESS - 14 ± 1 mils (0.356 ± 0.025 mm)

CHIP LAYOUT

Electrical Characteristics at 25°C

The chip is 100% probed to the actual conditions and limits specified.

Characteristic	Test Conditions	Limits		Units
		PCF10N12L		
		Min.	Max.	
BV_{DSS}	$I_D=1 \text{ mA}$ $V_{GS}=0$	120	—	V
$V_{GS(TH)}$	$V_{GS}=V_{DS}$ $I_D=1 \text{ mA}$	1	2	V
I_{OSS}	$V_{DS}=100 \text{ V}$	—	1	μA
I_{GSS}	$V_{GS}=\pm 10 \text{ V}$ $V_{DS}=0$	—	100	nA
$V_{DS(ON)}^a$	$I_D=5 \text{ A}$ $V_{GS}=5 \text{ V}$	—	1.5	V
g_{fs}^a	$V_{DS}=10 \text{ V}$ $I_D=5 \text{ A}$	2	—	mho

^aPulsed; pulse duration=300 μs max., duty factor=2%.

JEDEC TO-204AA

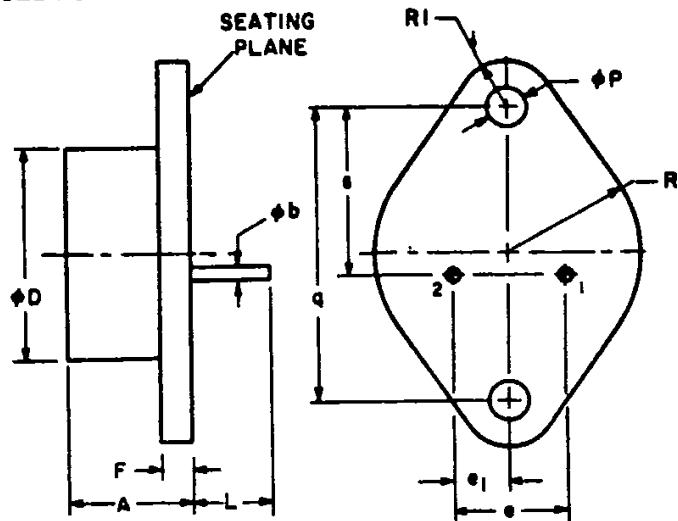

SYMBOL	INCHES		MILLIMETERS		NOTE
	MIN.	MAX.	MIN.	MAX.	
A	0.250	0.450	6.4	11.4	
ϕb	0.038	0.043	0.968	1.092	
ϕD	—	0.875	—	22.22	
e	0.420	0.440	10.67	11.17	
e_1	0.205	0.225	5.21	5.71	
F	—	0.135	—	3.42	
L	0.312	—	7.93	—	
ϕP	0.151	0.161	3.84	4.08	
q	1.187 BSC		30.15 BSC		
R	—	0.525	—	13.33	
R ₁	—	0.188	—	4.77	
s	0.655	0.675	16.64	17.14	

92CS-37249R1

JEDEC TO-204AE

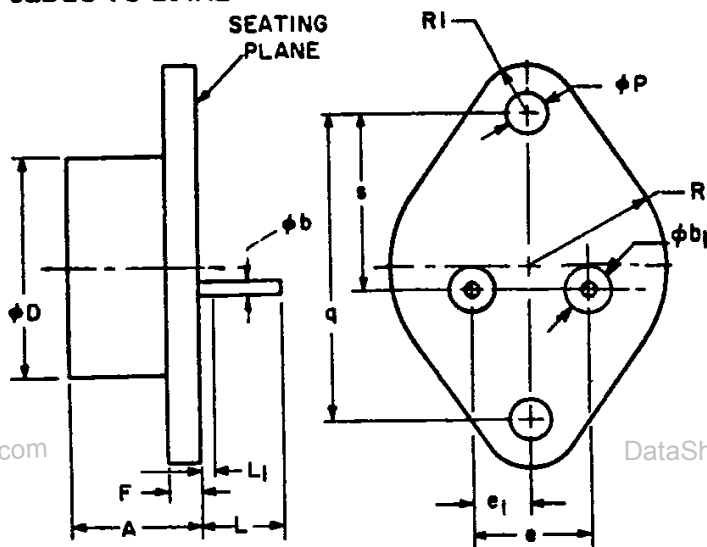

SYMBOL	INCHES		MILLIMETERS		NOTES
	MIN.	MAX.	MIN.	MAX.	
A	0.250	0.450	6.4	11.4	
ϕb	0.057	0.063	1.45	1.60	
ϕb_1	0.141 NOM		3.58 NOM		
ϕD_2	—	0.875	—	22.22	
e	0.420	0.440	10.67	11.17	
e_1	0.205	0.225	5.21	5.71	
F	0.060	0.135	1.53	3.42	
L	0.440	0.480	11.18	12.19	
ϕP	0.151	0.161	3.84	4.08	
q	1.187 BSC		30.15 BSC		
R	0.495	0.525	12.58	13.33	
R ₁	0.131	0.188	3.33	4.77	
s	0.655	0.675	16.64	17.14	

92CS-37523

JEDEC TO-205AF

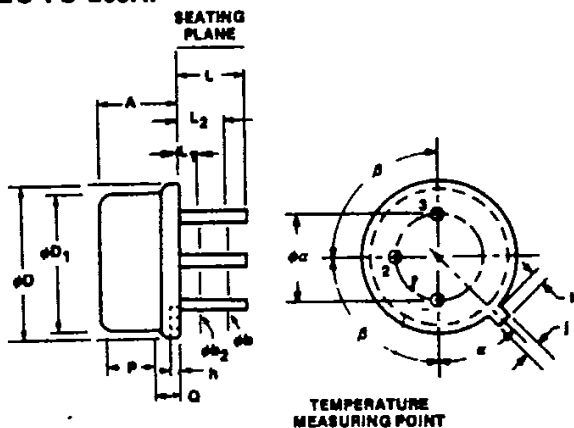

Notes:

1. Dimension k measured from ϕD maximum.
2. ϕD_1 shall not vary more than 0.010 in Zone P. This zone controlled for automatic handling.
3. Details of outline in this zone optional.
4. Leads at gauge plane 0.054-0.055 below seating plane shall be within 0.007 radius of positional tolerance at MMC relative to tab at MMC. Device may be measured by direct methods or by gauge and gauging procedure described on JEDEC gauge drawing G8-1.
5. ϕb_2 applies between L₁ and L₂. ϕb applies between L₂ and L minimum. Diameter is uncontrolled in L₁ and beyond L minimum.

SYMBOL	INCHES		MILLIMETERS		NOTES
	MIN.	MAX.	MIN.	MAX.	
ϕa	0.200 BSC		5.08 BSC		4
A	0.160	0.180	4.07	4.57	
ϕb	0.016	0.021	0.41	0.53	5
ϕb_2	0.016	0.019	0.41	0.48	5
ϕD	0.340	0.370	8.64	9.39	
ϕD_1	0.315	0.355	8.01	9.01	2
h	0.009	0.041	0.23	1.04	
j	0.028	0.034	0.72	0.86	
k	0.029	0.045	0.74	1.14	1
L	0.500	0.750	12.70	19.05	5
L ₁	—	0.050	—	1.27	5
L ₂	0.250	—	6.35	—	5
P	0.070	—	1.78	—	2
Q	—	0.050	—	1.27	3
α	45° NOMINAL				
β	90° NOMINAL				

92CS-38248R1

JEDEC TO-218AC

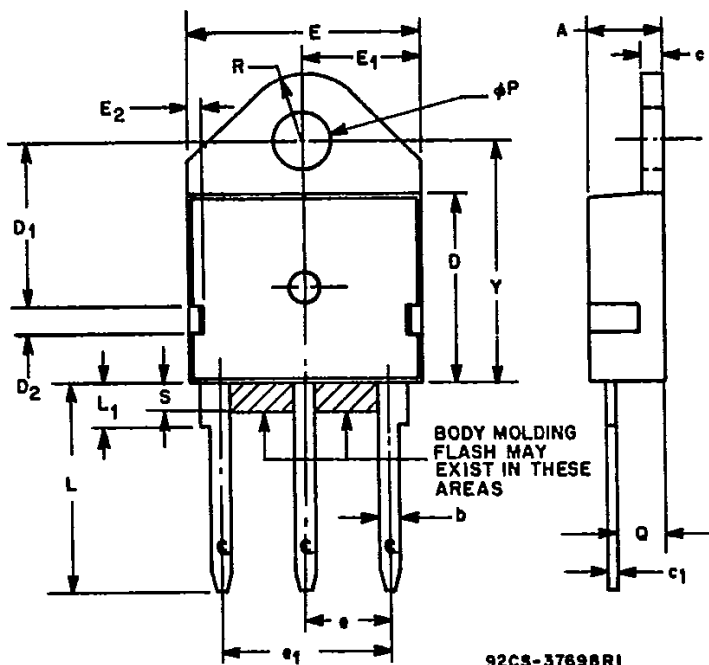

92CS-37698R1

Notes:

- 1: Tab outline optional within boundaries of dimensions E and R.
- 2: Lead dimensions uncontrolled in L1.
- 3: Controlling dimensions: inch.

SYMBOL	INCHES		MILLIMETERS		NOTES
	MIN.	MAX.	MIN.	MAX.	
A	.165	.200	4.191	5.080	
b	.040	.063	1.016	1.600	
c	.053	.065	1.346	1.651	
c1	.018	.030	.457	.762	
D	.485	.505	12.319	12.827	
D1	.395	.415	10.033	10.541	
D2	.070	.090	1.778	2.286	
E	.610	.640	15.494	16.256	1
E1	.305	.320	7.747	8.128	
E2	.040	.060	1.016	1.524	
e	.205	.225	5.207	5.715	
e1	.420	.440	10.688	11.176	
L	.500	.610	12.700	15.494	
L1	—	.125	—	3.175	2
phi P	.157	.167	3.988	4.241	
Q	.094	.126	2.388	3.200	
R	.170	.190	4.318	4.828	
S	—	0.60	—	1.524	
Y	.626	.670	15.900	17.018	

92CS-37698R1

JEDEC TO-220AB

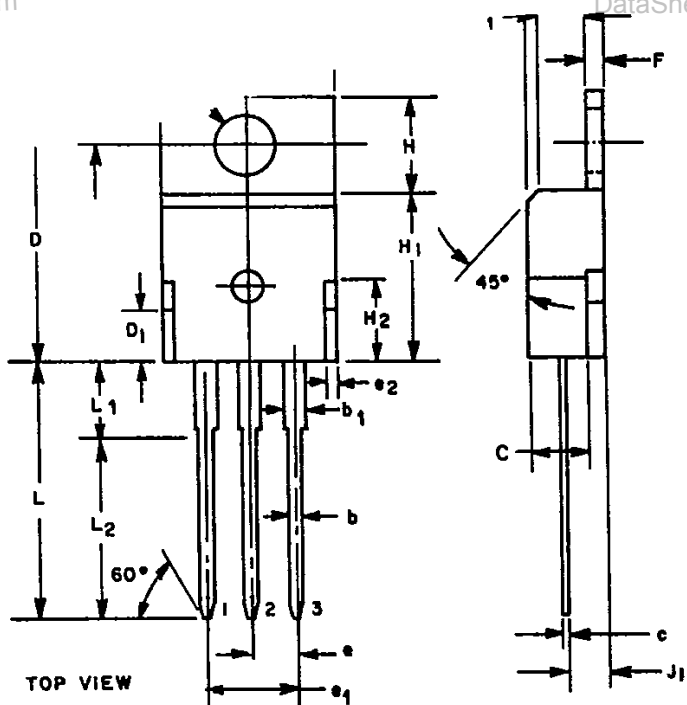

92CS-34697R1

NOTES:

- 1. Position of lead to be measured 0.250-0.255 in. (6.350-6.477 mm) from case.

SYMBOL	INCHES		MILLIMETERS	
	MIN.	MAX.	MIN.	MAX.
A	0.140	0.190	3.56	4.82
A1	0.080	0.085	2.03	2.16
b	0.020	0.045	0.51	1.14
b1	0.045	0.070	1.14	1.77
C	—	0.125	—	3.18
c	0.015	0.025	0.38	0.63
D	0.560	0.625	14.23	15.87
D1	—	0.100	—	2.54
E	0.380	0.420	9.66	10.66
e	0.090	0.110	2.29	2.79
e1	0.190	0.210	4.83	5.33
e2	—	0.030	—	0.76
F	0.045	0.055	1.14	1.39
H	0.230	0.270	5.85	6.85
H1	0.355	0.370	9.02	9.40
H2	—	0.160	—	4.06
J1	0.080	0.115	2.04	2.92
L	0.500	0.562	12.70	14.27
L1	—	0.250	—	6.35
L2	0.400	0.410	10.16	10.41
phi P	0.139	0.161	3.531	4.089
Q	0.100	0.120	2.54	3.04

92CS-34697R1

Dimensional Outlines

JEDEC TO-220AC

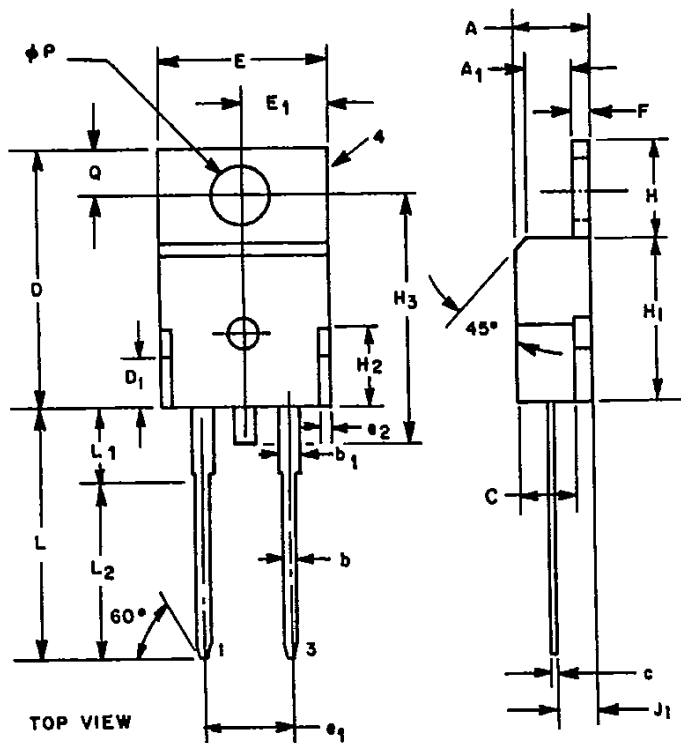

NOTES:

1. Position of lead to be measured 0.250-0.255 in. (6.350-6.477 mm) from case.

SYMBOL	INCHES		MILLIMETERS	
	MIN.	MAX.	MIN.	MAX.
A	0.140	0.190	3.56	4.82
A ₁	0.080	0.085	2.03	2.16
b	0.020	0.045	0.51	1.14
b ₁	0.045	0.070	1.14	1.77
C	—	0.125	—	3.18
c	0.015	0.025	0.38	0.63
D	0.560	0.825	14.23	15.87
D ₁	—	0.100	—	2.54
E	0.380	0.420	9.66	10.66
e ₁	0.190	0.210	4.83	5.33
e ₂	—	0.030	—	0.76
F	0.045	0.055	1.14	1.39
H	0.230	0.270	5.85	6.85
H ₁	0.355	0.370	9.02	9.40
H ₂	—	0.160	—	4.08
H ₃	—	0.600	—	15.24
J ₁	0.080	0.115	2.04	2.92
L	0.500	0.562	12.70	14.27
L ₁	—	0.250	—	6.35
L ₂	0.400	0.410	10.16	10.41
φP	0.139	0.161	3.531	4.089
Q	0.100	0.120	2.54	3.04

92CS-34830R1

T-91-20

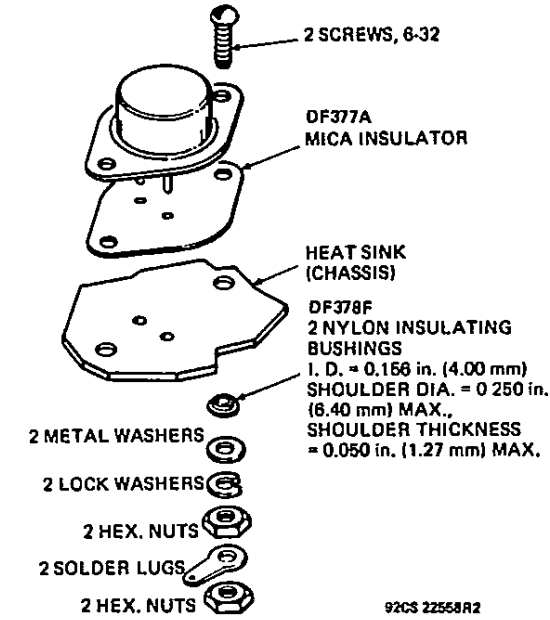

NOTE MAXIMUM TORQUE APPLIED TO MOUNTING
FLANGE IS 12 in.-lbs. (0.14 kgf m)

**Suggested mounting hardware for JEDEC TO-204AA
(formerly JEDEC TO-3)**

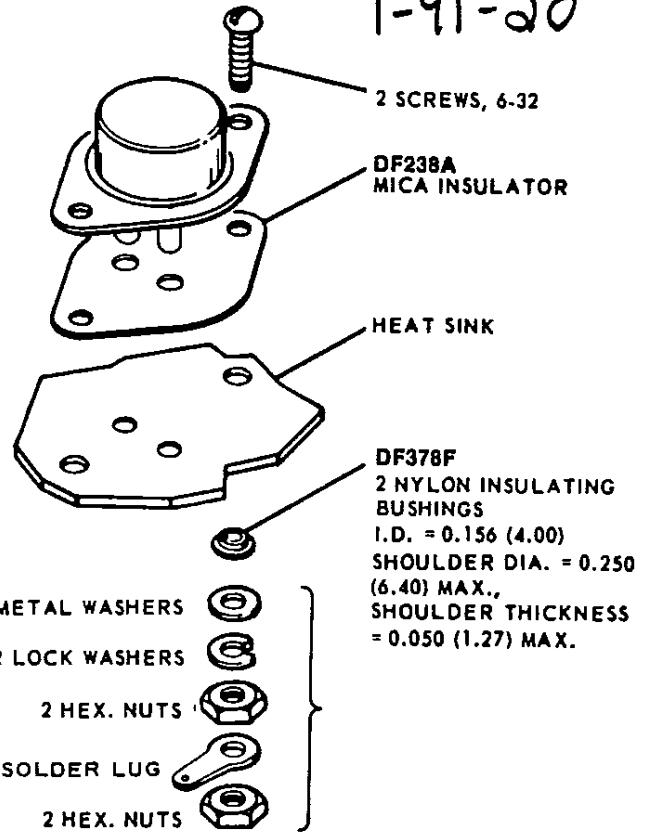

**Suggested mounting hardware for JEDEC TO-204AE
(formerly JEDEC TO-3)**

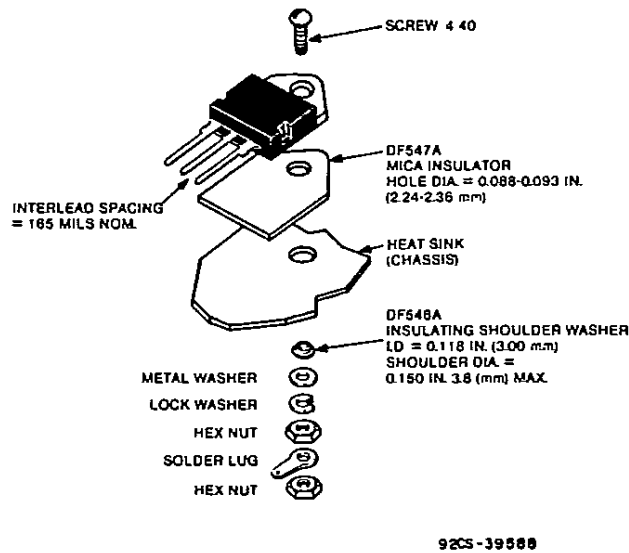

Suggested mounting hardware for JEDEC TO-218AC

Mounting Hardware

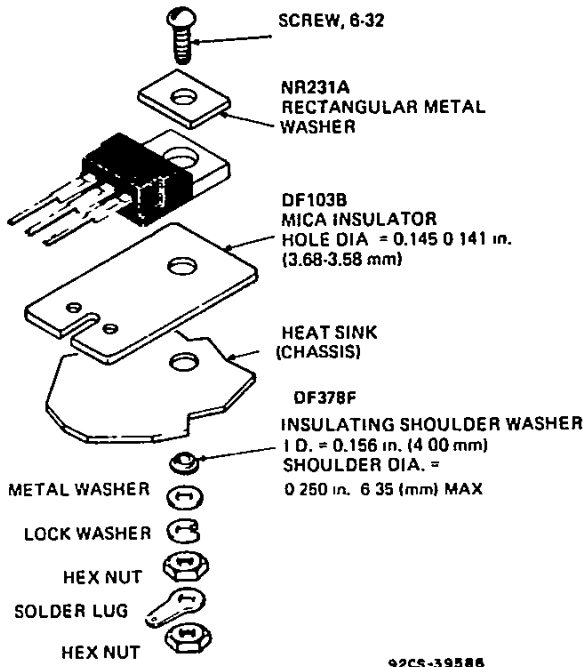

NOTE: MAXIMUM TORQUE APPLIED TO MOUNTING
FLANGE IS 8 in. lb. (0.09 kgf m)

Suggested mounting hardware for JEDEC TO-220AB

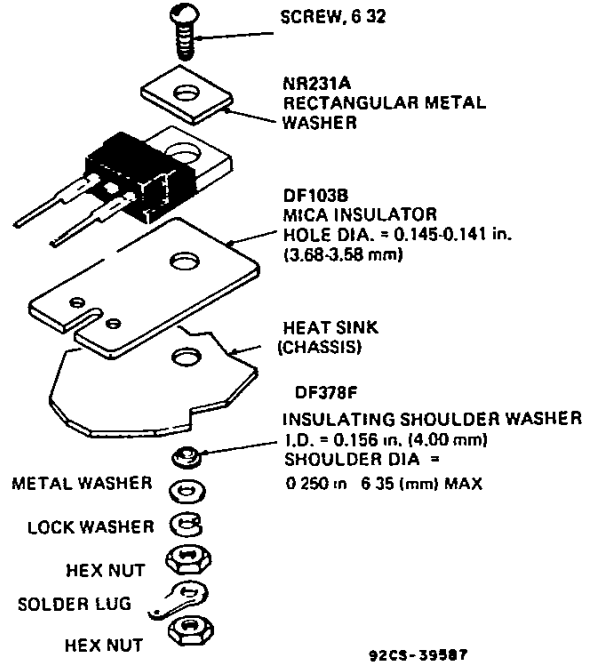

NOTE: MAXIMUM TORQUE APPLIED TO MOUNTING
FLANGE IS 8 in. lb. (0.09 kgf m)

Suggested mounting hardware for JEDEC TO-220AC