

**PCI4510 PDV/GHK/RGVF/RZVF/ZHK**  
**PC Card and Integrated 1394a-2000 OHCI Two-Port**  
**PHY/Link-Layer Controller**

*Data Manual*

## IMPORTANT NOTICE

Texas Instruments Incorporated and its subsidiaries (TI) reserve the right to make corrections, modifications, enhancements, improvements, and other changes to its products and services at any time and to discontinue any product or service without notice. Customers should obtain the latest relevant information before placing orders and should verify that such information is current and complete. All products are sold subject to TI's terms and conditions of sale supplied at the time of order acknowledgment.

TI warrants performance of its hardware products to the specifications applicable at the time of sale in accordance with TI's standard warranty. Testing and other quality control techniques are used to the extent TI deems necessary to support this warranty. Except where mandated by government requirements, testing of all parameters of each product is not necessarily performed.

TI assumes no liability for applications assistance or customer product design. Customers are responsible for their products and applications using TI components. To minimize the risks associated with customer products and applications, customers should provide adequate design and operating safeguards.

TI does not warrant or represent that any license, either express or implied, is granted under any TI patent right, copyright, mask work right, or other TI intellectual property right relating to any combination, machine, or process in which TI products or services are used. Information published by TI regarding third-party products or services does not constitute a license from TI to use such products or services or a warranty or endorsement thereof. Use of such information may require a license from a third party under the patents or other intellectual property of the third party, or a license from TI under the patents or other intellectual property of TI.

Reproduction of information in TI data books or data sheets is permissible only if reproduction is without alteration and is accompanied by all associated warranties, conditions, limitations, and notices. Reproduction of this information with alteration is an unfair and deceptive business practice. TI is not responsible or liable for such altered documentation.

Resale of TI products or services with statements different from or beyond the parameters stated by TI for that product or service voids all express and any implied warranties for the associated TI product or service and is an unfair and deceptive business practice. TI is not responsible or liable for any such statements.

Following are URLs where you can obtain information on other Texas Instruments products and application solutions:

<b>Products</b>		<b>Applications</b>	
Amplifiers	<a href="http://amplifier.ti.com">amplifier.ti.com</a>	Audio	<a href="http://www.ti.com/audio">www.ti.com/audio</a>
Data Converters	<a href="http://dataconverter.ti.com">dataconverter.ti.com</a>	Automotive	<a href="http://www.ti.com/automotive">www.ti.com/automotive</a>
DSP	<a href="http://dsp.ti.com">dsp.ti.com</a>	Broadband	<a href="http://www.ti.com/broadband">www.ti.com/broadband</a>
Interface	<a href="http://interface.ti.com">interface.ti.com</a>	Digital Control	<a href="http://www.ti.com/digitalcontrol">www.ti.com/digitalcontrol</a>
Logic	<a href="http://logic.ti.com">logic.ti.com</a>	Military	<a href="http://www.ti.com/military">www.ti.com/military</a>
Power Mgmt	<a href="http://power.ti.com">power.ti.com</a>	Optical Networking	<a href="http://www.ti.com/opticalnetwork">www.ti.com/opticalnetwork</a>
Microcontrollers	<a href="http://microcontroller.ti.com">microcontroller.ti.com</a>	Security	<a href="http://www.ti.com/security">www.ti.com/security</a>
		Telephony	<a href="http://www.ti.com/telephony">www.ti.com/telephony</a>
		Video & Imaging	<a href="http://www.ti.com/video">www.ti.com/video</a>
		Wireless	<a href="http://www.ti.com/wireless">www.ti.com/wireless</a>

Mailing Address: Texas Instruments  
Post Office Box 655303 Dallas, Texas 75265

# Contents

<i>Section</i>	<i>Title</i>	<i>Page</i>
<b>1</b>	<b>Introduction</b>	<b>1-1</b>
1.1	Description	1-1
1.2	Features	1-2
1.3	Related Documents	1-3
1.4	Trademarks	1-4
1.5	Ordering Information	1-4
1.6	PCI4510 Data Manual Document History	1-4
<b>2</b>	<b>Terminal Descriptions</b>	<b>2-1</b>
<b>3</b>	<b>Feature/Protocol Descriptions</b>	<b>3-1</b>
3.1	Power Supply Sequencing	3-1
3.2	I/O Characteristics	3-1
3.3	Clamping Voltages	3-2
3.4	Peripheral Component Interconnect (PCI) Interface	3-2
3.4.1	1394 PCI Bus Master	3-2
3.4.2	PCI GRST Signal	3-2
3.4.3	PCI Bus Lock ( $\overline{\text{LOCK}}$ )	3-3
3.4.4	Loading CardBus (Function 0) Subsystem Identification	3-3
3.5	PC Card Applications	3-4
3.5.1	PC Card Insertion/Removal and Recognition	3-4
3.5.2	Zoomed Video Support	3-4
3.5.3	Standardized Zoomed-Video Register Model	3-6
3.5.4	Internal Ring Oscillator	3-6
3.5.5	Integrated Pullup Resistors for PC Card Interface	3-6
3.5.6	SPKROUT and CAUDPWM Usage	3-7
3.5.7	LED Socket Activity Indicators	3-8
3.5.8	CardBus Socket Registers	3-8
3.6	Serial EEPROM Interface	3-8
3.6.1	Serial-Bus Interface Implementation	3-9
3.6.2	Serial-Bus Interface Protocol	3-9
3.6.3	Serial-Bus EEPROM Application	3-11
3.6.4	Accessing Serial-Bus Devices Through Software	3-12
3.7	Programmable CardBus Interrupt Subsystem	3-13
3.7.1	PC Card Functional and Card Status Change Interrupts	3-13
3.7.2	Interrupt Masks and Flags	3-15
3.7.3	Using Parallel IRQ Interrupts	3-15
3.7.4	Using Parallel PCI Interrupts	3-16
3.7.5	Using Serialized IRQSER Interrupts	3-16
3.7.6	SMI Support in the PCI4510 Device	3-16

<i>Section</i>	<i>Title</i>	<i>Page</i>
3.8	Power Management Overview .....	3-17
3.8.1	1394 Power Management (Function 1) .....	3-17
3.8.2	Integrated Low-Dropout Voltage Regulator (LDO-VR) ....	3-17
3.8.3	CardBus (Function 0) Clock Run Protocol .....	3-18
3.8.4	CardBus PC Card Power Management .....	3-18
3.8.5	16-Bit PC Card Power Management .....	3-18
3.8.6	Suspend Mode .....	3-18
3.8.7	Requirements for Suspend Mode .....	3-19
3.8.8	Ring Indicate .....	3-19
3.8.9	PCI Power Management for CardBus (Function 0) .....	3-20
3.8.10	CardBus Bridge Power Management .....	3-21
3.8.11	ACPI Support .....	3-22
3.8.12	Master List of PME Context Bits and Global Reset-Only Bits for CardBus (Function 0) .....	3-22
3.8.13	Master List of Global Reset-Only Bits for 1394 OHCI (Function 1) .....	3-23
3.9	Low-Voltage CardBus Card Detection .....	3-23
3.10	Power Switch Interface .....	3-24
3.11	IEEE 1394 Application Information .....	3-25
3.11.1	PHY Port Cable Connection .....	3-25
3.11.2	Crystal Selection .....	3-26
3.11.3	Bus Reset .....	3-27
<b>4</b>	<b>PC Card Controller Programming Model .....</b>	<b>4-1</b>
4.1	PCI Configuration Registers (Function 0) .....	4-1
4.2	Vendor ID Register .....	4-2
4.3	Device ID Register .....	4-2
4.4	Command Register .....	4-3
4.5	Status Register .....	4-4
4.6	Class Code and Revision ID Registers .....	4-5
4.7	Cache Line Size Register .....	4-5
4.8	Latency Timer Register .....	4-5
4.9	Header Type Register .....	4-6
4.10	BIST Register .....	4-6
4.11	CardBus Socket Registers/ExCA Base Address Register .....	4-6
4.12	Capability Pointer Register .....	4-7
4.13	Secondary Status Register .....	4-8
4.14	PCI Bus Number Register .....	4-9
4.15	CardBus Bus Number Register .....	4-9
4.16	Subordinate Bus Number Register .....	4-9
4.17	CardBus Latency Timer Register .....	4-10
4.18	CardBus Memory Base Registers 0, 1 .....	4-10
4.19	CardBus Memory Limit Registers 0, 1 .....	4-11
4.20	CardBus I/O Base Registers 0, 1 .....	4-11

<i>Section</i>	<i>Title</i>	<i>Page</i>
4.21	CardBus I/O Limit Registers 0, 1 .....	4–12
4.22	Interrupt Line Register .....	4–12
4.23	Interrupt Pin Register .....	4–13
4.24	Bridge Control Register .....	4–14
4.25	Subsystem Vendor ID Register .....	4–15
4.26	Subsystem ID Register .....	4–15
4.27	PC Card 16-Bit I/F Legacy-Mode Base-Address Register .....	4–15
4.28	System Control Register .....	4–16
4.29	General Control Register .....	4–18
4.30	General-Purpose Event Status Register .....	4–19
4.31	General-Purpose Event Enable Register .....	4–20
4.32	General-Purpose Input Register .....	4–20
4.33	General-Purpose Output Register .....	4–21
4.34	Multifunction Routing Status Register .....	4–22
4.35	Retry Status Register .....	4–23
4.36	Card Control Register .....	4–24
4.37	Device Control Register .....	4–25
4.38	Diagnostic Register .....	4–26
4.39	Capability ID Register .....	4–27
4.40	Next Item Pointer Register .....	4–27
4.41	Power Management Capabilities Register .....	4–28
4.42	Power Management Control/Status Register .....	4–29
4.43	Power Management Control/Status Bridge Support Extensions Register .....	4–30
4.44	Serial Bus Data Register .....	4–30
4.45	Serial Bus Index Register .....	4–31
4.46	Serial Bus Slave Address Register .....	4–31
4.47	Serial Bus Control and Status Register .....	4–32
<b>5</b>	<b>ExCA Compatibility Registers (Function 0) .....</b>	<b>5–1</b>
5.1	ExCA Identification and Revision Register .....	5–4
5.2	ExCA Interface Status Register .....	5–5
5.3	ExCA Power Control Register .....	5–6
5.4	ExCA Interrupt and General Control Register .....	5–7
5.5	ExCA Card Status-Change Register .....	5–8
5.6	ExCA Card Status-Change Interrupt Configuration Register .....	5–9
5.7	ExCA Address Window Enable Register .....	5–10
5.8	ExCA I/O Window Control Register .....	5–11
5.9	ExCA I/O Windows 0 and 1 Start-Address Low-Byte Registers ....	5–12
5.10	ExCA I/O Windows 0 and 1 Start-Address High-Byte Registers ....	5–12
5.11	ExCA I/O Windows 0 and 1 End-Address Low-Byte Registers ....	5–12
5.12	ExCA I/O Windows 0 and 1 End-Address High-Byte Registers ....	5–13
5.13	ExCA Memory Windows 0–4 Start-Address Low-Byte Registers ...	5–13

<i>Section</i>	<i>Title</i>	<i>Page</i>
5.14	ExCA Memory Windows 0–4 Start-Address High-Byte Registers . . .	5–14
5.15	ExCA Memory Windows 0–4 End-Address Low-Byte Registers . . . .	5–15
5.16	ExCA Memory Windows 0–4 End-Address High-Byte Registers . . .	5–15
5.17	ExCA Memory Windows 0–4 Offset-Address Low-Byte Registers . .	5–16
5.18	ExCA Memory Windows 0–4 Offset-Address High-Byte Registers . .	5–17
5.19	ExCA Card Detect and General Control Register . . . . .	5–18
5.20	ExCA Global Control Register . . . . .	5–19
5.21	ExCA I/O Windows 0 and 1 Offset-Address Low-Byte Registers . . .	5–20
5.22	ExCA I/O Windows 0 and 1 Offset-Address High-Byte Registers . . .	5–20
5.23	ExCA Memory Windows 0–4 Page Registers . . . . .	5–20
<b>6</b>	<b>CardBus Socket Registers (Function 0)</b> . . . . .	<b>6–1</b>
6.1	Socket Event Register . . . . .	6–2
6.2	Socket Mask Register . . . . .	6–3
6.3	Socket Present State Register . . . . .	6–4
6.4	Socket Force Event Register . . . . .	6–5
6.5	Socket Control Register . . . . .	6–7
6.6	Socket Power Management Register . . . . .	6–8
<b>7</b>	<b>OHCI Controller Programming Model</b> . . . . .	<b>7–1</b>
7.1	Vendor ID Register . . . . .	7–2
7.2	Device ID Register . . . . .	7–2
7.3	Command Register . . . . .	7–3
7.4	Status Register . . . . .	7–4
7.5	Class Code and Revision ID Register . . . . .	7–5
7.6	Latency Timer and Class Cache Line Size Register . . . . .	7–5
7.7	Header Type and BIST Register . . . . .	7–6
7.8	OHCI Base Address Register . . . . .	7–6
7.9	TI Extension Base Address Register . . . . .	7–7
7.10	CardBus CIS Base Address Register . . . . .	7–7
7.11	CardBus CIS Pointer Register . . . . .	7–8
7.12	Subsystem Identification Register . . . . .	7–8
7.13	Power Management Capabilities Pointer Register . . . . .	7–9
7.14	Interrupt Line Register . . . . .	7–9
7.15	Interrupt Pin Register . . . . .	7–10
7.16	MIN_GNT and MAX_LAT Register . . . . .	7–10
7.17	OHCI Control Register . . . . .	7–11
7.18	Capability ID and Next Item Pointer Registers . . . . .	7–11
7.19	Power Management Capabilities Register . . . . .	7–12
7.20	Power Management Control and Status Register . . . . .	7–13
7.21	Power Management Extension Registers . . . . .	7–13
7.22	PCI PHY Control Register . . . . .	7–14
7.23	PCI Miscellaneous Configuration Register . . . . .	7–15
7.24	Link Enhancement Control Register . . . . .	7–16
7.25	Subsystem Access Register . . . . .	7–17

<i>Section</i>	<i>Title</i>	<i>Page</i>
<b>8</b>	<b>OHCI Registers</b>	<b>8-1</b>
8.1	OHCI Version Register	8-4
8.2	GUID ROM Register	8-5
8.3	Asynchronous Transmit Retries Register	8-6
8.4	CSR Data Register	8-6
8.5	CSR Compare Register	8-7
8.6	CSR Control Register	8-7
8.7	Configuration ROM Header Register	8-8
8.8	Bus Identification Register	8-8
8.9	Bus Options Register	8-9
8.10	GUID High Register	8-10
8.11	GUID Low Register	8-10
8.12	Configuration ROM Mapping Register	8-11
8.13	Posted Write Address Low Register	8-11
8.14	Posted Write Address High Register	8-12
8.15	Vendor ID Register	8-12
8.16	Host Controller Control Register	8-13
8.17	Self-ID Buffer Pointer Register	8-14
8.18	Self-ID Count Register	8-15
8.19	Isochronous Receive Channel Mask High Register	8-16
8.20	Isochronous Receive Channel Mask Low Register	8-17
8.21	Interrupt Event Register	8-18
8.22	Interrupt Mask Register	8-20
8.23	Isochronous Transmit Interrupt Event Register	8-22
8.24	Isochronous Transmit Interrupt Mask Register	8-23
8.25	Isochronous Receive Interrupt Event Register	8-24
8.26	Isochronous Receive Interrupt Mask Register	8-25
8.27	Initial Bandwidth Available Register	8-25
8.28	Initial Channels Available High Register	8-26
8.29	Initial Channels Available Low Register	8-26
8.30	Fairness Control Register	8-27
8.31	Link Control Register	8-28
8.32	Node Identification Register	8-29
8.33	PHY Layer Control Register	8-30
8.34	Isochronous Cycle Timer Register	8-31
8.35	Asynchronous Request Filter High Register	8-32
8.36	Asynchronous Request Filter Low Register	8-34
8.37	Physical Request Filter High Register	8-35
8.38	Physical Request Filter Low Register	8-37
8.39	Physical Upper Bound Register (Optional Register)	8-37
8.40	Asynchronous Context Control Register	8-38
8.41	Asynchronous Context Command Pointer Register	8-39

<i>Section</i>	<i>Title</i>	<i>Page</i>
8.42	Isochronous Transmit Context Control Register .....	8–40
8.43	Isochronous Transmit Context Command Pointer Register .....	8–41
8.44	Isochronous Receive Context Control Register .....	8–41
8.45	Isochronous Receive Context Command Pointer Register .....	8–43
8.46	Isochronous Receive Context Match Register .....	8–44
<b>9</b>	<b>TI Extension Registers .....</b>	<b>9–1</b>
9.1	DV and MPEG2 Timestamp Enhancements .....	9–1
9.2	Isochronous Receive Digital Video Enhancements .....	9–2
9.3	Isochronous Receive Digital Video Enhancements Register .....	9–2
9.4	Link Enhancement Register .....	9–4
9.5	Timestamp Offset Register .....	9–5
<b>10</b>	<b>PHY Register Configuration .....</b>	<b>10–1</b>
10.1	Base Registers .....	10–1
10.2	Port Status Register .....	10–4
10.3	Vendor Identification Register .....	10–5
10.4	Vendor-Dependent Register .....	10–6
10.5	Power-Class Programming .....	10–7
<b>11</b>	<b>Electrical Characteristics .....</b>	<b>11–1</b>
11.1	Absolute Maximum Ratings Over Operating Temperature Ranges .....	11–1
11.2	Recommended Operating Conditions .....	11–2
11.3	Electrical Characteristics Over Recommended Operating Conditions .....	11–3
11.4	Electrical Characteristics Over Recommended Ranges of Operating Conditions .....	11–4
	11.4.1 Device .....	11–4
	11.4.2 Driver .....	11–4
	11.4.3 Receiver .....	11–4
11.5	PCI Clock/Reset Timing Requirements Over Recommended Ranges of Supply Voltage and Operating Free-Air Temperature .....	11–5
11.6	Switching Characteristics for PHY Port Interface .....	11–5
11.7	Operating, Timing, and Switching Characteristics of XI .....	11–5
11.8	PCI Timing Requirements Over Recommended Ranges of Supply Voltage and Operating Free-Air Temperature .....	11–5
	11.8.1 CardBus PC Card Clock Specifications .....	11–6
	11.8.2 3.3-V Timing Parameters .....	11–6
<b>12</b>	<b>Mechanical Information .....</b>	<b>12–1</b>



## List of Illustrations

<i>Figure</i>	<i>Title</i>	<i>Page</i>
2-1	PCI4510 GHK Terminal Diagram .....	2-2
2-2	PCI4510 RGVF Terminal Diagram .....	2-3
2-3	PCI4510 PDV-Package Terminal Diagram .....	2-4
3-1	PCI4510 System Block Diagram .....	3-1
3-2	3-State Bidirectional Buffer .....	3-2
3-3	Zoomed Video Implementation Using the PCI4510 Device .....	3-5
3-4	Zoomed Video Switching Application .....	3-5
3-5	Sample Application of SPKROUT and CAUDPWM .....	3-7
3-6	Two Sample LED Circuits .....	3-8
3-7	Serial-Bus Start/Stop Conditions and Bit Transfers .....	3-9
3-8	Serial-Bus Protocol Acknowledge .....	3-9
3-9	Serial-Bus Protocol – Byte Write .....	3-10
3-10	Serial-Bus Protocol – Byte Read .....	3-10
3-11	EEPROM Interface Doubleword Data Collection .....	3-10
3-12	IRQ Implementation .....	3-16
3-13	Signal Diagram of Suspend Function .....	3-19
3-14	$\overline{\text{RI\_OUT}}$ Functional Diagram .....	3-20
3-15	Block Diagram of a Status/Enable Cell .....	3-22
3-16	TP Cable Connections .....	3-25
3-17	Typical Compliant DC Isolated Outer Shield Termination .....	3-25
3-18	Non-DC Isolated Outer Shield Termination .....	3-26
3-19	Load Capacitance for the PCI4510 PHY .....	3-27
3-20	Recommended Crystal and Capacitor Layout .....	3-27
5-1	ExCA Register Access Through I/O .....	5-1
5-2	ExCA Register Access Through Memory .....	5-1
6-1	Accessing CardBus Socket Registers Through PCI Memory .....	6-1
11-1	Test Load Diagram .....	11-4
11-2	CardBus PC Card Clock Waveform .....	11-6

## List of Tables

<i>Table</i>	<i>Title</i>	<i>Page</i>
2-1	Signal Names Sorted by PDV Terminal Number .....	2-5
2-2	Signal Names Sorted by GHK Terminal Number .....	2-7
2-3	Signal Names Sorted by RGVF Terminal Number .....	2-9
2-4	CardBus PC Card Signal Names Sorted Alphabetically .....	2-11
2-5	16-Bit PC Card Signal Names Sorted Alphabetically .....	2-13
2-6	Power Supply Terminals .....	2-15
2-7	PC Card Power Switch Terminals .....	2-15
2-8	PCI System Terminals .....	2-15
2-9	PCI Address and Data Terminals .....	2-16
2-10	PCI Interface Control Terminals .....	2-17
2-11	Multifunction and Miscellaneous Terminals .....	2-18
2-12	16-Bit PC Card Address and Data Terminals .....	2-19
2-13	16-Bit PC Card Interface Control Terminals .....	2-20
2-14	CardBus PC Card Interface System Terminals .....	2-21
2-15	CardBus PC Card Address and Data Terminals .....	2-22
2-16	CardBus PC Card Interface Control Terminals .....	2-23
2-17	IEEE 1394 Physical Layer Terminals .....	2-24
2-18	Power Supply Terminals .....	2-25
2-19	Smart Card and Memory Card Terminals .....	2-25
3-1	PCI Bus Master Command Support .....	3-2
3-2	PC Card Card-Detect and Voltage-Sense Connections .....	3-4
3-3	Integrated Pullup Resistors .....	3-7
3-4	CardBus Socket Registers .....	3-8
3-5	EEPROM Loading Map .....	3-11
3-6	PCI4510 Registers Used to Program Serial-Bus Devices .....	3-13
3-7	Interrupt Mask and Flag Registers .....	3-14
3-8	PC Card Interrupt Events and Description .....	3-14
3-9	Interrupt Pin Register Cross Reference .....	3-16
3-10	SMI Control .....	3-17
3-11	Requirements for Internal/External 1.8-V Core Power Supply .....	3-18
3-12	Power-Management Registers .....	3-21
3-13	TPS2221 Control Logic .....	3-24
3-14	TPS2211A Control Logic .....	3-24
4-1	Bit Field Access Tag Descriptions .....	4-1
4-2	Function 0 PCI Configuration Register Map .....	4-1
4-3	Command Register Description .....	4-3
4-4	Status Register Description .....	4-4

<i>Table</i>	<i>Title</i>	<i>Page</i>
4-5	Secondary Status Register Description .....	4-8
4-6	PCI Interrupt Pin Register—Read-Only INTPIN Per Function .....	4-13
4-7	Bridge Control Register Description .....	4-14
4-8	System Control Register Description .....	4-16
4-9	General Control Register Description .....	4-18
4-10	General-Purpose Event Status Register Description .....	4-19
4-11	General-Purpose Event Enable Register Description .....	4-20
4-12	General-Purpose Input Register Description .....	4-20
4-13	General-Purpose Output Register Description .....	4-21
4-14	Multifunction Routing Status Register Description .....	4-22
4-15	Retry Status Register Description .....	4-23
4-16	Card Control Register Description .....	4-24
4-17	Device Control Register Description .....	4-25
4-18	Diagnostic Register Description .....	4-26
4-19	Power Management Capabilities Register Description .....	4-28
4-20	Power Management Control/Status Register Description .....	4-29
4-21	Power Management Control/Status Bridge Support Extensions Register Description .....	4-30
4-22	Serial Bus Data Register Description .....	4-30
4-23	Serial Bus Index Register Description .....	4-31
4-24	Serial Bus Slave Address Register Description .....	4-31
4-25	Serial Bus Control and Status Register Description .....	4-32
5-1	ExCA Registers and Offsets .....	5-2
5-2	ExCA Identification and Revision Register Description .....	5-4
5-3	ExCA Interface Status Register Description .....	5-5
5-4	ExCA Power Control Register Description—82365SL Support .....	5-6
5-5	ExCA Power Control Register Description—82365SL-DF Support .....	5-6
5-6	ExCA Interrupt and General Control Register Description .....	5-7
5-7	ExCA Card Status-Change Register Description .....	5-8
5-8	ExCA Card Status-Change Interrupt Configuration Register Description .....	5-9
5-9	ExCA Address Window Enable Register Description .....	5-10
5-10	ExCA I/O Window Control Register Description .....	5-11
5-11	ExCA Memory Windows 0-4 Start-Address High-Byte Registers Description .....	5-14
5-12	ExCA Memory Windows 0-4 End-Address High-Byte Registers Description .....	5-15
5-13	ExCA Memory Windows 0-4 Offset-Address High-Byte Registers Description .....	5-17
5-14	ExCA Card Detect and General Control Register Description .....	5-18
5-15	ExCA Global Control Register Description .....	5-19
6-1	CardBus Socket Registers .....	6-1
6-2	Socket Event Register Description .....	6-2
6-3	Socket Mask Register Description .....	6-3

<i>Table</i>	<i>Title</i>	<i>Page</i>
6-4	Socket Present State Register Description .....	6-4
6-5	Socket Force Event Register Description .....	6-6
6-6	Socket Control Register Description .....	6-7
6-7	Socket Power Management Register Description .....	6-8
7-1	Function 1 Configuration Register Map .....	7-1
7-2	Command Register Description .....	7-3
7-3	Status Register Description .....	7-4
7-4	Class Code and Revision ID Register Description .....	7-5
7-5	Latency Timer and Class Cache Line Size Register Description .....	7-5
7-6	Header Type and BIST Register Description .....	7-6
7-7	OHCI Base Address Register Description .....	7-6
7-8	TI Base Address Register Description .....	7-7
7-9	Subsystem Identification Register Description .....	7-8
7-10	Interrupt Line Register Description .....	7-9
7-11	PCI Interrupt Pin Register—Read-Only INTPIN Per Function .....	7-10
7-12	MIN_GNT and MAX_LAT Register Description .....	7-10
7-13	OHCI Control Register Description .....	7-11
7-14	Capability ID and Next Item Pointer Registers Description .....	7-11
7-15	Power Management Capabilities Register Description .....	7-12
7-16	Power Management Control and Status Register Description .....	7-13
7-17	Power Management Extension Registers Description .....	7-13
7-18	PCI PHY Control Register .....	7-14
7-19	Miscellaneous Configuration Register .....	7-15
7-20	Link Enhancement Control Register Description .....	7-16
7-21	Subsystem Access Register Description .....	7-17
8-1	OHCI Register Map .....	8-1
8-2	OHCI Version Register Description .....	8-4
8-3	GUID ROM Register Description .....	8-5
8-4	Asynchronous Transmit Retries Register Description .....	8-6
8-5	CSR Control Register Description .....	8-7
8-6	Configuration ROM Header Register Description .....	8-8
8-7	Bus Options Register Description .....	8-9
8-8	Configuration ROM Mapping Register Description .....	8-11
8-9	Posted Write Address Low Register Description .....	8-11
8-10	Posted Write Address High Register Description .....	8-12
8-11	Host Controller Control Register Description .....	8-13
8-12	Self-ID Count Register Description .....	8-15
8-13	Isochronous Receive Channel Mask High Register Description .....	8-16
8-14	Isochronous Receive Channel Mask Low Register Description .....	8-17
8-15	Interrupt Event Register Description .....	8-18
8-16	Interrupt Mask Register Description .....	8-20
8-17	Isochronous Transmit Interrupt Event Register Description .....	8-22
8-18	Isochronous Receive Interrupt Event Register Description .....	8-24

<i>Table</i>	<i>Title</i>	<i>Page</i>
8–19	Initial Bandwidth Available Register Description . . . . .	8–25
8–20	Initial Channels Available High Register Description . . . . .	8–26
8–21	Initial Channels Available Low Register Description . . . . .	8–26
8–22	Fairness Control Register Description . . . . .	8–27
8–23	Link Control Register Description . . . . .	8–28
8–24	Node Identification Register Description . . . . .	8–29
8–25	PHY Control Register Description . . . . .	8–30
8–26	Isochronous Cycle Timer Register Description . . . . .	8–31
8–27	Asynchronous Request Filter High Register Description . . . . .	8–32
8–28	Asynchronous Request Filter Low Register Description . . . . .	8–34
8–29	Physical Request Filter High Register Description . . . . .	8–35
8–30	Physical Request Filter Low Register Description . . . . .	8–37
8–31	Asynchronous Context Control Register Description . . . . .	8–38
8–32	Asynchronous Context Command Pointer Register Description . . . . .	8–39
8–33	Isochronous Transmit Context Control Register Description . . . . .	8–40
8–34	Isochronous Receive Context Control Register Description . . . . .	8–41
8–35	Isochronous Receive Context Match Register Description . . . . .	8–44
9–1	TI Extension Register Map . . . . .	9–1
9–2	Isochronous Receive Digital Video Enhancements Register Description . . . . .	9–2
9–3	Link Enhancement Register Description . . . . .	9–4
9–4	Timestamp Offset Register Description . . . . .	9–5
10–1	Base Register Configuration . . . . .	10–1
10–2	Base Register Field Descriptions . . . . .	10–2
10–3	Page 0 (Port Status) Register Configuration . . . . .	10–4
10–4	Page 0 (Port Status) Register Field Descriptions . . . . .	10–4
10–5	Page 1 (Vendor ID) Register Configuration . . . . .	10–5
10–6	Page 1 (Vendor ID) Register Field Descriptions . . . . .	10–5
10–7	Page 7 (Vendor-Dependent) Register Configuration . . . . .	10–6
10–8	Page 7 (Vendor-Dependent) Register Field Descriptions . . . . .	10–6
10–9	Power Class Descriptions . . . . .	10–7



# 1 Introduction

The Texas Instruments PCI4510 device is an integrated single-socket PC Card controller with an IEEE 1394 open host controller link-layer controller (LLC) and two-port 1394 PHY. This high performance integrated solution provides the latest in both PC Card and IEEE 1394 technology.

## 1.1 Description

The Texas Instruments PCI4510 device is compliant with *PCI Local Bus Specification*. Function 0 provides the independent PC Card socket controller compliant with the latest *PC Card Standards*. The PCI4510 device provides features that make it the best choice for bridging between the PCI bus and PC Cards, and supports either 16-bit or CardBus PC Cards in the socket, powered at 5 V or 3.3 V, as required.

There are no PCMCIA card and socket service software changes required to move systems from the existing CardBus socket controller to the PCI4510 device. The PCI4510 device is register compatible with the Intel 82365SL–DF ExCA controller and implements the host interface defined in the *PC Card Standard*. The PCI4510 internal data path logic allows the host to access 8-, 16-, and 32-bit cards using full 32-bit PCI cycles for maximum performance. Independent buffering and the pipeline architecture provides an unsurpassed performance level with sustained bursting. The PCI4510 device can be programmed to accept posted writes to improve bus utilization. All card signals are internally buffered to allow hot insertion and removal without external buffering.

Function 1 of the PCI4510 device is an integrated IEEE 1394a-2000 open host controller interface (OHCI) PHY/link-layer controller (LLC) device that is fully compliant with the *PCI Local Bus Specification*, the *PCI Bus Power Management Interface Specification*, IEEE Std 1394-1995, IEEE Std 1394a-2000, and the *1394 Open Host Controller Interface Specification*. It is capable of transferring data between the 33-MHz PCI bus and the 1394 bus at 100M bits/s, 200M bits/s, and 400M bits/s. The PCI4510 device provides two 1394 ports that have separate cable bias (TPBIAS). The PCI4510 device also supports the IEEE Std 1394a-2000 power-down features for battery-operated applications and arbitration enhancements.

As required by the *1394 Open Host Controller Interface Specification* and IEEE Std 1394a-2000, internal control registers are memory-mapped and nonprefetchable. The PCI configuration header is accessed through configuration cycles specified by PCI, and it provides plug-and-play (PnP) compatibility. Furthermore, the PCI4510 device is compliant with the *PCI Bus Power Management Interface Specification* as specified by the *PC 2001 Design Guide* requirements. The PCI4510 device supports the D0, D1, D2, and D3 power states.

The PCI4510 design provides PCI bus master bursting, and it is capable of transferring a cacheline of data at 132M bytes/s after connection to the memory controller. Because PCI latency can be large, deep FIFOs are provided to buffer the IEEE 1394 data.

The PCI4510 device provides physical write posting buffers and a highly-tuned physical data path for SBP-2 performance. The PCI4510 device also provides multiple isochronous contexts, multiple cacheline burst transfers, advanced internal arbitration, and bus-holding buffers.

The PCI4510 PHY-layer provides the digital and analog transceiver functions needed to implement a two-port node in a cable-based 1394 network. Each cable port incorporates two differential line transceivers. The transceivers include circuitry to monitor the line conditions as needed for determining connection status, for initialization and arbitration, and for packet reception and transmission.

The PCI4510 PHY-layer requires only an external 24.576-MHz crystal as a reference for the cable ports. An external clock may be provided instead of a crystal. An internal oscillator drives an internal phase-locked loop (PLL), which generates the required 393.216-MHz reference signal. This reference signal is internally divided to provide the clock signals that control transmission of the outbound encoded strobe and data information. A 49.152-MHz clock signal is supplied to the integrated LLC for synchronization and is used for resynchronization of the received data. Data bits to be transmitted through the cable ports are received from the integrated LLC and are latched internally in

synchronization with the 49.152-MHz system clock. These bits are combined serially, encoded, and transmitted at 98.304M, 196.608M, or 393.216M bits/s (referred to as S100, S200, or S400 speeds, respectively) as the outbound data-strobe information stream. During transmission, the encoded data information is transmitted differentially on the twisted-pair B (TPB) cable pair(s), and the encoded strobe information is transmitted differentially on the twisted-pair A (TPA) cable pair(s).

Various implementation-specific functions and general-purpose inputs and outputs are provided through several multifunction terminals. These terminals present a system with options, such as PCI LOCK and parallel IRQs. ACPI-complaint general-purpose events may be programmed and controlled through the multifunction terminals, and an ACPI-compliant programming interface is included for the general-purpose inputs and outputs.

The PCI4510 device is compliant with the latest *PCI Bus Power Management Specification*, and provides several low-power modes, which enable the host power system to further reduce power consumption. The PCI4510 device also has a four-pin interface compatible with both the TI TPS2211A and TPS2221 power switches.

An advanced CMOS process achieves low power consumption and allows the PCI4510 device to operate at PCI clock rates up to 33 MHz.

## 1.2 Features

The PCI4510 device supports the following features:

- *PC Card Standard 8.0* compliant
- *PCI Bus Power Management Interface Specification 1.1* compliant
- *Advanced Configuration and Power Interface Specification 2.0* compliant
- *PCI Local Bus Specification Revision 2.2* compliant
- PC 98/99 and PC2001 compliant
- Compliant with the *PCI Bus Interface Specification* for PCI-to-CardBus Bridges
- Fully compliant with provisions of IEEE Std 1394-1995 for a high-performance serial bus and IEEE Std 1394a-2000
- Fully compliant with *1394 Open Host Controller Interface Specification 1.1*
- Compatible with both TPS2211A and TPS2221 PC Card power switches
- 1.8-V core logic and 3.3-V I/O cells with internal voltage regulator to generate 1.8-V core  $V_{CC}$
- Universal PCI interfaces compatible with 3.3-V and 5-V PCI signaling environments
- Supports PC Card or CardBus with hot insertion and removal
- Supports 132-MBps burst transfers to maximize data throughput on both the PCI bus and the CardBus
- Supports serialized IRQ with PCI interrupts
- Programmable multifunction terminals
- Serial ROM interface for loading subsystem ID and subsystem vendor ID
- ExCA-compatible registers are mapped in memory or I/O space
- Intel 82365SL-DF register compatible
- Supports ring indicate,  $\overline{\text{SUSPEND}}$ , PCI  $\overline{\text{CCLKRUN}}$  protocol, and PCI bus lock ( $\overline{\text{LOCK}}$ )
- Provides VGA/palette memory and I/O, and subtractive decoding options, LED activity terminals
- Fully interoperable with FireWire™ and i.LINK™ implementations of IEEE Std 1394
- Compliant with *Intel Mobile Power Guideline 2000*



- Full IEEE Std 1394a-2000 support includes: connection debounce, arbitrated short reset, multispeed concatenation, arbitration acceleration, fly-by concatenation, and port disable/suspend/resume
- Power-down features to conserve energy in battery-powered applications include: automatic device power down during suspend, PCI power management for link-layer and inactive ports powered down, ultralow-power sleep mode
- Two IEEE Std 1394a-2000 fully compliant cable ports at 100M bits/s, 200M bits/s, and 400M bits/s
- Cable ports monitor line conditions for active connection to remote node
- Cable power presence monitoring
- Separate cable bias (TPBIAS) for each port
- Physical write posting of up to three outstanding transactions
- PCI burst transfers and deep FIFOs to tolerate large host latency
- External cycle timer control for customized synchronization
- Extended resume signaling for compatibility with legacy DV components
- PHY-Link logic performs system initialization and arbitration functions
- PHY-Link encode and decode functions included for data-strobe bit level encoding
- PHY-Link incoming data resynchronized to local clock
- Low-cost 24.576-MHz crystal provides transmit and receive data at 100M bits/s, 200M bits/s, and 400M bits/s
- Node power class information signaling for system power management
- Register bits give software control of contender bit, power class bits, link active control bit, and IEEE Std 1394a-2000 features
- Isochronous receive dual-buffer mode
- Out-of-order pipelining for asynchronous transmit requests
- Register access fail interrupt when the PHY SCLK is not active
- PCI power-management D0, D1, D2, and D3 power states
- Initial bandwidth available and initial channels available registers
- $\overline{\text{PME}}$  support per *1394 Open Host Controller Interface Specification*
- Advanced submicron, low-power CMOS technology

### 1.3 Related Documents

- *Advanced Configuration and Power Interface (ACPI) Specification* (Revision 2.0)
- *1394 Open Host Controller Interface Specification* (Release 1.1)
- *IEEE Standard for a High Performance Serial Bus* (IEEE Std 1394-1995)
- *IEEE Standard for a High Performance Serial Bus—Amendment 1* (IEEE Std 1394a-2000)
- *PC Card Standard—Electrical Specification* (Release 8.0)
- *PC 2001 Design Guide*
- *PCI Bus Power Management Interface Specification* (Revision 1.1)
- *PCI Local Bus Specification* (Revision 2.2)

- *Mobile Power Guidelines 2000*
- *Serial Bus Protocol 2 (SBP-2)*
- *Serialized IRQ Support for PCI Systems*
- *PCI Mobile Design Guide*
- *PCI Bus Power Management Interface Specification for PCI to CardBus Bridges*
- *PCI14xx Implementation Guide for D3 Wake-Up*
- *PCI to PCMCIA CardBus Bridge Register Description*
- Texas Instruments TPS2221 product data sheet, SLVS419
- Texas Instruments TPS2211A product data sheet, SLVS282

## 1.4 Trademarks

Intel is a trademark of Intel Corporation.

TI and MicroStar BGA are trademarks of Texas Instruments.

FireWire is a trademark of Apple Computer, Inc.

i.LINK is a trademark of Sony Corporation of America.

Other trademarks are the property of their respective owners.

## 1.5 Ordering Information

ORDERING NUMBER	NAME	VOLTAGE	PACKAGE
PCI4510	PC Card and integrated 1394a-2000 OHCI two-port PHY/link-layer controller	3.3-V, 5-V tolerant I/Os	208-terminal LQFP (PDV) 209-ball PBGA (GHK/ZHK) 224-ball PBGA (RGVF/RZVF)

## 1.6 PCI4510 Data Manual Document History

DATE	PAGE NUMBER	REVISION
01/2003	1–2	Added a power-switch-compatibility item to the features list
03/2003	2–1	Added description for ZHK package
01/2003	2–25	Swapped terminal names for ANALOGVCC and ANALOGGND to avoid confusion
01/2003	3–2	Added new subsection 3.4.2 to describe $\overline{\text{GRST}}$ during power up
01/2003	3–10	Modified byte read diagram (Figure 3–10) to better reflect a read transaction to the EEPROM
01/2003	3–21	Modified description of power management capabilities register. This register is not a static read-only register.
08/2004	Chapters 1, 2, 3, 4, 12	Added RGVF/RZVF package and pinout information

## 2 Terminal Descriptions

The PCI4510 device is available in five packages, a 208-terminal quad flatpack (PDV), two 209-terminal MicroStar BGA™ packages (GHK/ZHK), and two 224-terminal MicroStar BGA™ packages (RGVF/RZVF). The GHK and ZHK packages are mechanically and electrically identical, but the ZHK is a lead-free design. Throughout the remainder of this manual, only the GHK package designator is used for either the GHK or the ZHK package. The RGVF and RZVF packages are mechanically and electrically identical, but the RZVF is a lead-free design. Throughout the remainder of this manual, only the RGVF package designator is used for either the RGVF or the RZVF package. The terminal layout for the GHK package is shown in Figure 2–1. The terminal layout for the RGVF package is shown in Figure 2–2. The terminal layout for the PDV package is shown in Figure 2–3.

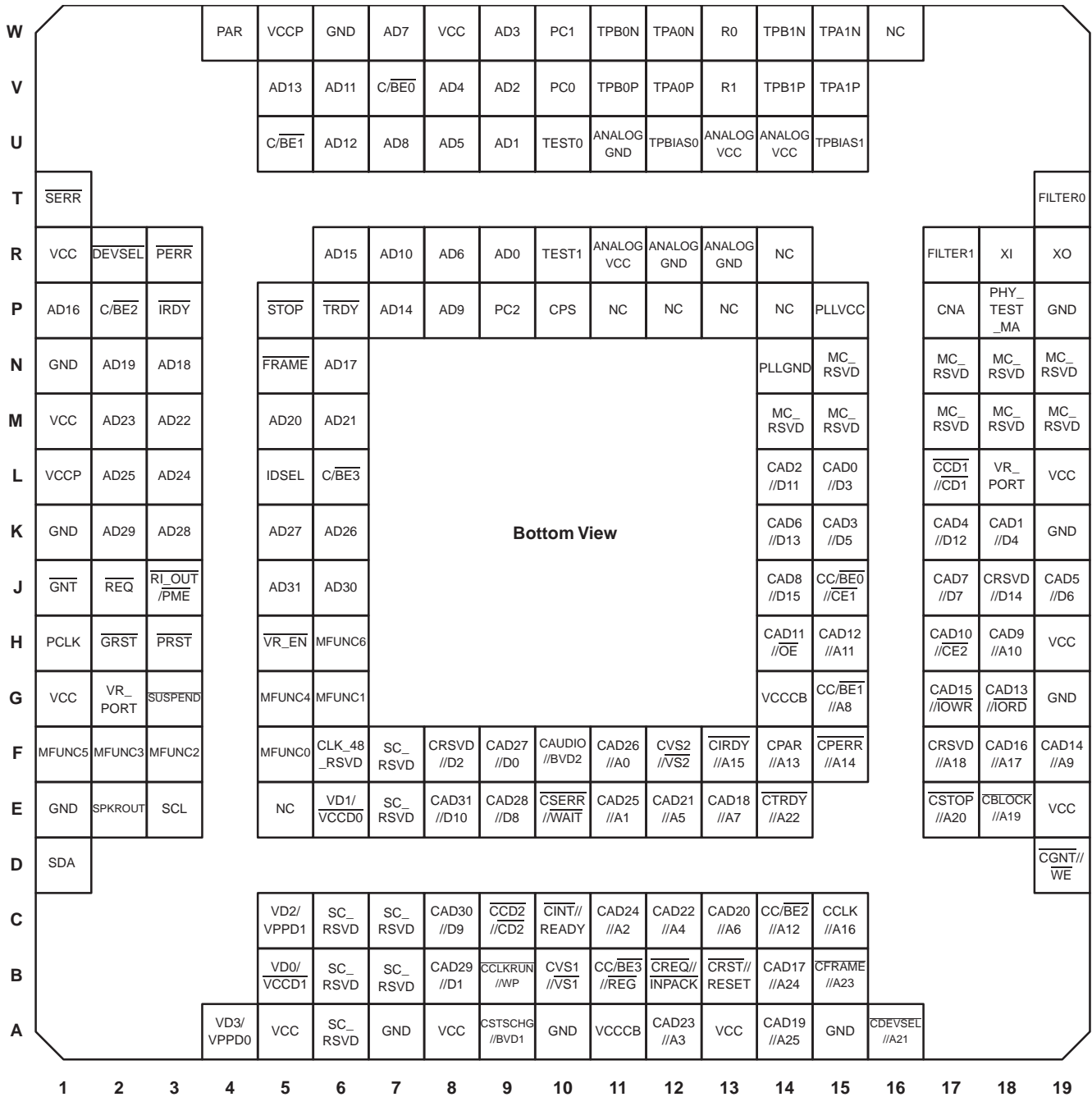

Figure 2-1. PCI4510 GHK Terminal Diagram

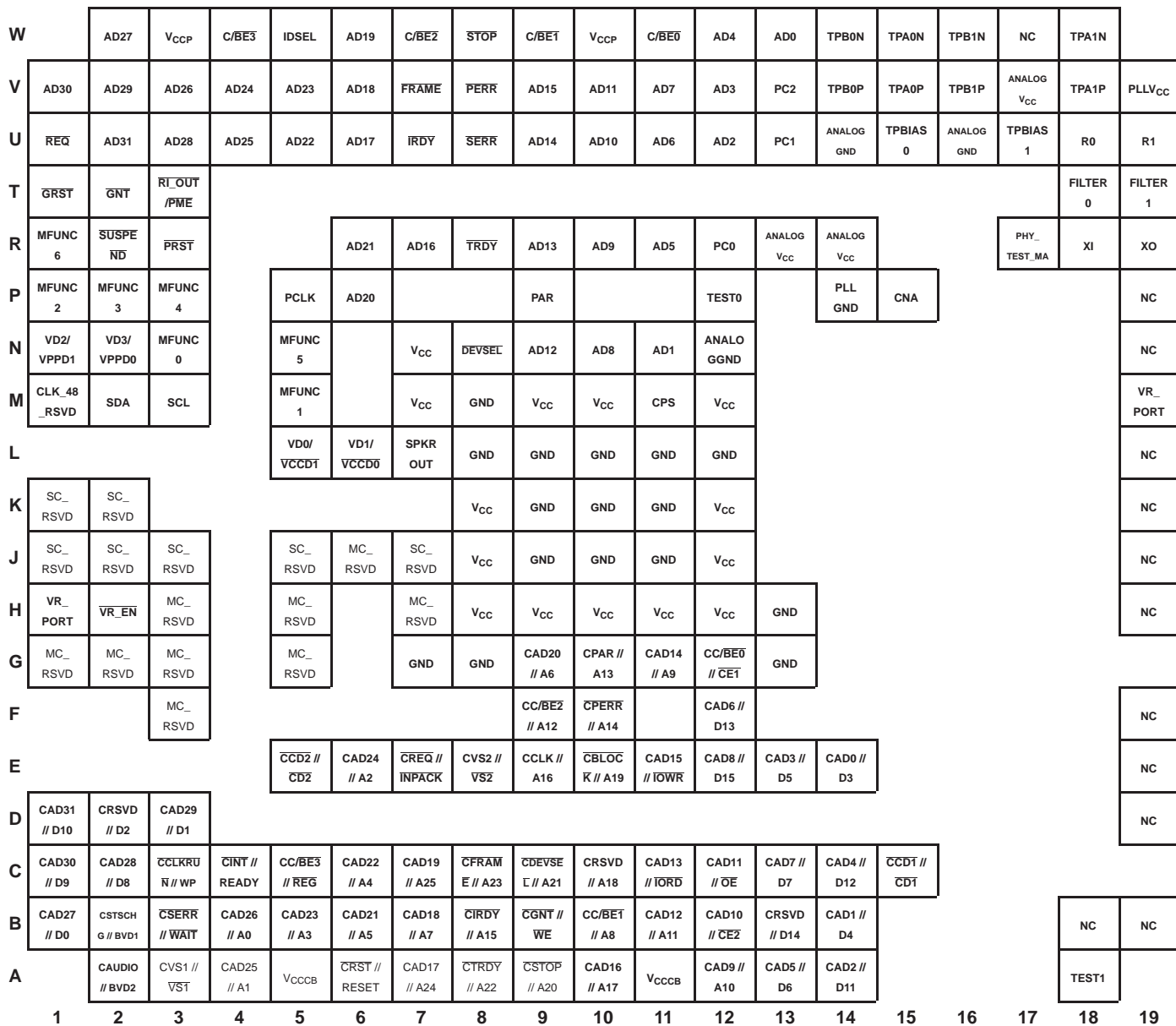
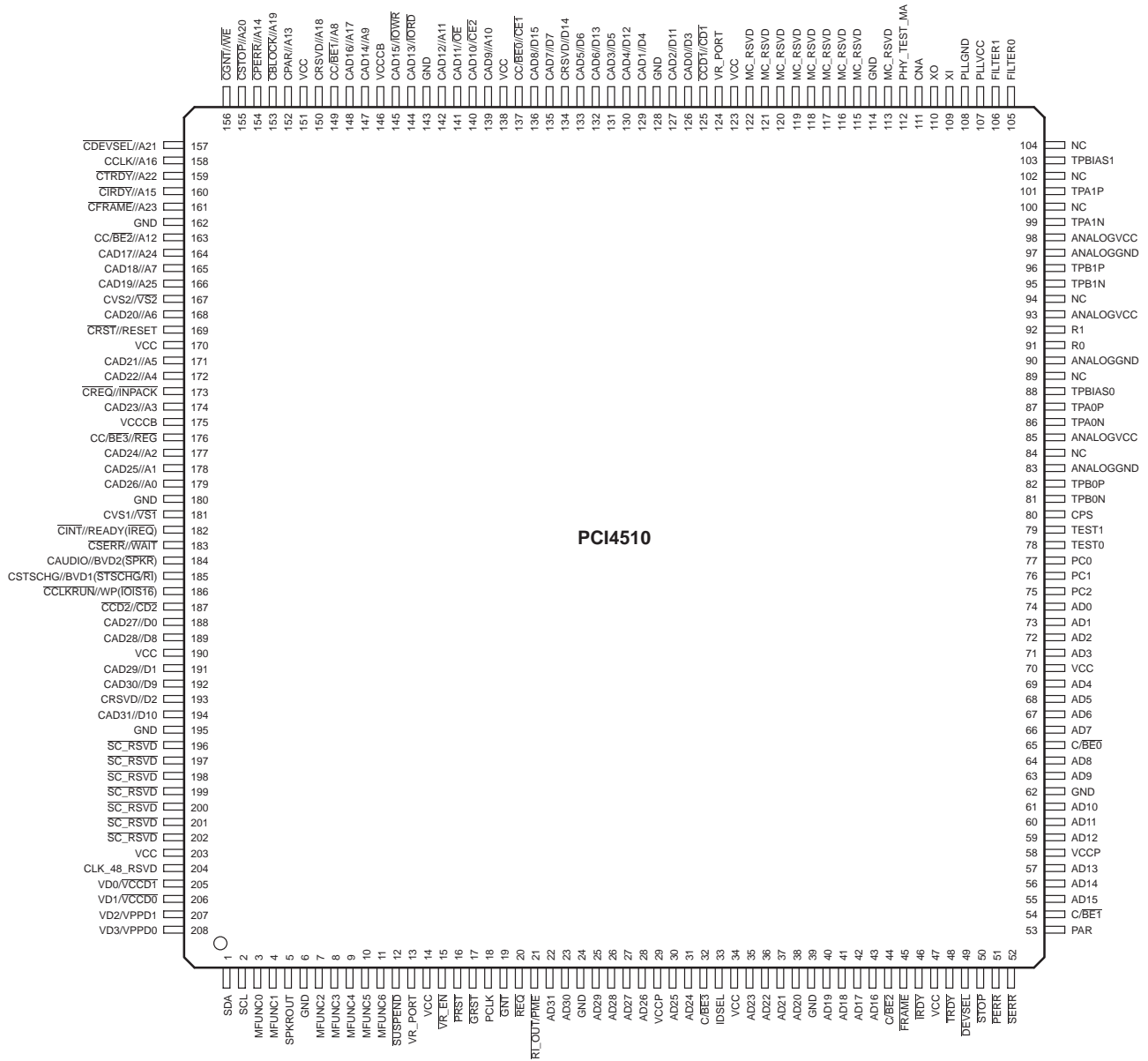

Figure 2–2. PCI4510 RGVF Terminal Diagram

**PDV LOW-PROFILE QUAD FLAT PACKAGE  
(LQFP)  
TOP VIEW**



**Figure 2-3. PCI4510 PDV-Package Terminal Diagram**

Table 2–1, Table 2–2, and Table 2–3 list the terminal assignments arranged in terminal-number order, with corresponding signal names for both CardBus and 16-bit PC Cards; Table 2–1 is for terminals on the PDV package, Table 2–2 is for terminals on the GHK package, and Table 2–3 is for terminals on the RGVF package. Table 2–4 and Table 2–5 list the terminal assignments arranged in alphanumeric order by signal name, with corresponding terminal numbers for the PDV, GHK, and RGVF packages; Table 2–4 is for CardBus signal names and Table 2–5 is for 16-bit PC Card signal names.

Terminal E5 on the GHK package is an identification ball used for device orientation; it has no internal connection within the device.

**Table 2–1. Signal Names Sorted by PDV Terminal Number**

TERM. NO.	SIGNAL NAME		TERM. NO.	SIGNAL NAME		TERM. NO.	SIGNAL NAME	
	CARDBUS	16-BIT		CARDBUS	16-BIT		CARDBUS	16-BIT
1	SDA	SDA	37	AD21	AD21	73	AD1	AD1
2	SCL	SCL	38	AD20	AD20	74	AD0	AD0
3	MFUNC0	MFUNC0	39	GND	GND	75	PC2	PC2
4	MFUNC1	MFUNC1	40	AD19	AD19	76	PC1	PC1
5	SPKROUT	SPKROUT	41	AD18	AD18	77	PC0	PC0
6	GND	GND	42	AD17	AD17	78	TEST0	TEST0
7	MFUNC2	MFUNC2	43	AD16	AD16	79	TEST1	TEST1
8	MFUNC3	MFUNC3	44	C/BE2	C/BE2	80	CPS	CPS
9	MFUNC4	MFUNC4	45	FRAME	FRAME	81	TPB0N	TPB0N
10	MFUNC5	MFUNC5	46	IRDY	IRDY	82	TPB0P	TPB0P
11	MFUNC6	MFUNC6	47	VCC	VCC	83	ANALOGGND	ANALOGGND
12	SUSPEND	SUSPEND	48	TRDY	TRDY	84	NC	NC
13	VR_PORT	VR_PORT	49	DEVSEL	DEVSEL	85	ANALOGVCC	ANALOGVCC
14	VCC	VCC	50	STOP	STOP	86	TPA0N	TPA0N
15	VR_EN	VR_EN	51	PERR	PERR	87	TPA0P	TPA0P
16	PRST	PRST	52	SERR	SERR	88	TPBIAS0	TPBIAS0
17	GRST	GRST	53	PAR	PAR	89	NC	NC
18	PCLK	PCLK	54	C/BE1	C/BE1	90	ANALOGGND	ANALOGGND
19	GNT	GNT	55	AD15	AD15	91	R0	R0
20	REQ	REQ	56	AD14	AD14	92	R1	R1
21	RI_OUT/PME	RI_OUT/PME	57	AD13	AD13	93	ANALOGVCC	ANALOGVCC
22	AD31	AD31	58	VCCP	VCCP	94	NC	NC
23	AD30	AD30	59	AD12	AD12	95	TPB1N	TPB1N
24	GND	GND	60	AD11	AD11	96	TPB1P	TPB1P
25	AD29	AD29	61	AD10	AD10	97	ANALOGGND	ANALOGGND
26	AD28	AD28	62	GND	GND	98	ANALOGVCC	ANALOGVCC
27	AD27	AD27	63	AD9	AD9	99	TPA1N	TPA1N
28	AD26	AD26	64	AD8	AD8	100	NC	NC
29	VCCP	VCCP	65	C/BE0	C/BE0	101	TPA1P	TPA1P
30	AD25	AD25	66	AD7	AD7	102	NC	NC
31	AD24	AD24	67	AD6	AD6	103	TPBIAS1	TPBIAS1
32	C/BE3	C/BE3	68	AD5	AD5	104	NC	NC
33	IDSEL	IDSEL	69	AD4	AD4	105	FILTER0	FILTER0
34	VCC	VCC	70	VCC	VCC	106	FILTER1	FILTER1
35	AD23	AD23	71	AD3	AD3	107	PLLVCC	PLLVCC
36	AD22	AD22	72	AD2	AD2	108	PLLGND	PLLGND

Table 2-1. Signal Names Sorted by PDV Terminal Number (Continued)

TERM. NO.	SIGNAL NAME		TERM. NO.	SIGNAL NAME		TERM. NO.	SIGNAL NAME	
	CARDBUS	16-BIT		CARDBUS	16-BIT		CARDBUS	16-BIT
109	XI	XI	143	GND	GND	177	CAD24	A2
110	XO	XO	144	CAD13	$\overline{\text{IORD}}$	178	CAD25	A1
111	CNA	CNA	145	CAD15	$\overline{\text{IOWR}}$	179	CAD26	A0
112	PHY_TEST_MA	PHY_TEST_MA	146	VCCCB	VCCCB	180	GND	GND
113	MC_RSVD	MC_RSVD	147	CAD14	A9	181	CVS1	$\overline{\text{VS1}}$
114	GND	GND	148	CAD16	A17	182	$\overline{\text{CINT}}$	READY( $\overline{\text{IREQ}}$ )
115	MC_RSVD	MC_RSVD	149	CC/BE1	A8	183	$\overline{\text{CSERR}}$	$\overline{\text{WAIT}}$
116	MC_RSVD	MC_RSVD	150	CRSVD	A18	184	CAUDIO	BVD2( $\overline{\text{SPKR}}$ )
117	MC_RSVD	MC_RSVD	151	VCC	VCC	185	CSTSCHG	BVD1( $\overline{\text{STSCHG/RI}}$ )
118	MC_RSVD	MC_RSVD	152	CPAR	A13	186	$\overline{\text{CCLKRUN}}$	WP( $\overline{\text{IOIS1}}$ )
119	MC_RSVD	MC_RSVD	153	$\overline{\text{CBLOCK}}$	A19	187	$\overline{\text{CCD2}}$	$\overline{\text{CD2}}$
120	MC_RSVD	MC_RSVD	154	$\overline{\text{CPERR}}$	A14	188	CAD27	D0
121	MC_RSVD	MC_RSVD	155	$\overline{\text{CSTOP}}$	A20	189	CAD28	D8
122	MC_RSVD	MC_RSVD	156	$\overline{\text{CGNT}}$	$\overline{\text{WE}}$	190	VCC	VCC
123	VCC	VCC	157	$\overline{\text{CDEVSEL}}$	A21	191	CAD29	D1
124	VR_PORT	VR_PORT	158	CCLK	A16	192	CAD30	D9
125	$\overline{\text{CCD1}}$	$\overline{\text{CD1}}$	159	$\overline{\text{CTRDY}}$	A22	193	CRSVD	D2
126	CAD0	D3	160	$\overline{\text{CIRDY}}$	A15	194	CAD31	D10
127	CAD2	D11	161	$\overline{\text{CFRAME}}$	A23	195	GND	GND
128	GND	GND	162	GND	GND	196	SC_RSVD	SC_RSVD
129	CAD1	D4	163	CC/BE2	A12	197	SC_RSVD	SC_RSVD
130	CAD4	D12	164	CAD17	A24	198	SC_RSVD	SC_RSVD
131	CAD3	D5	165	CAD18	A7	199	SC_RSVD	SC_RSVD
132	CAD6	D13	166	CAD19	A25	200	SC_RSVD	SC_RSVD
133	CAD5	D6	167	CVS2	$\overline{\text{VS2}}$	201	SC_RSVD	SC_RSVD
134	CRSVD	D14	168	CAD20	A6	202	SC_RSVD	SC_RSVD
135	CAD7	D7	169	$\overline{\text{CRST}}$	RESET	203	VCC	VCC
136	CAD8	D15	170	VCC	VCC	204	CLK_48_RSVD	CLK_48_RSVD
137	CC/BE0	$\overline{\text{CE1}}$	171	CAD21	A5	205	VD0/ $\overline{\text{VCCD1}}$	VD0/ $\overline{\text{VCCD1}}$
138	VCC	VCC	172	CAD22	A4	206	VD1/ $\overline{\text{VCCD0}}$	VD1/ $\overline{\text{VCCD0}}$
139	CAD9	A10	173	$\overline{\text{CREQ}}$	$\overline{\text{INPACK}}$	207	VD2/VPPD1	VD2/VPPD1
140	CAD10	$\overline{\text{CE2}}$	174	CAD23	A3	208	VD3/VPPD0	VD3/VPPD0
141	CAD11	$\overline{\text{OE}}$	175	VCCCB	VCCCB			
142	CAD12	A11	176	CC/BE3	$\overline{\text{REG}}$			



Table 2-2. Signal Names Sorted by GHK Terminal Number

TERM. NO.	SIGNAL NAME		TERM. NO.	SIGNAL NAME		TERM. NO.	SIGNAL NAME	
	CARDBUS	16-BIT		CARDBUS	16-BIT		CARDBUS	16-BIT
A04	VD3/VPPD0	VD3/VPPD0	E07	SC_RSVD	SC_RSVD	H06	MFUNC6	MFUNC6
A05	VCC	VCC	E08	CAD31	D10	H14	CAD11	$\overline{OE}$
A06	SC_RSVD	SC_RSVD	E09	CAD28	D8	H15	CAD12	A11
A07	GND	GND	E10	$\overline{CSERR}$	$\overline{WAIT}$	H17	CAD10	$\overline{CE2}$
A08	VCC	VCC	E11	CAD25	A1	H18	CAD9	A10
A09	CSTSCHG	BVD1( $\overline{STSCHG/RI}$ )	E12	CAD21	A5	H19	VCC	VCC
A10	GND	GND	E13	CAD18	A7	J01	$\overline{GNT}$	$\overline{GNT}$
A11	VCCCB	VCCCB	E14	$\overline{CTRDY}$	A22	J02	$\overline{REQ}$	$\overline{REQ}$
A12	CAD23	A3	E17	$\overline{CSTOP}$	A20	J03	$\overline{RI\_OUT/PME}$	$\overline{RI\_OUT/PME}$
A13	VCC	VCC	E18	$\overline{CBLOCK}$	A19	J05	AD31	AD31
A14	CAD19	A25	E19	VCC	VCC	J06	AD30	AD30
A15	GND	GND	F01	MFUNC5	MFUNC5	J14	CAD8	D15
A16	$\overline{CDEVSEL}$	A21	F02	MFUNC3	MFUNC3	J15	CC/BE0	$\overline{CE1}$
B05	VD0/VCCD1	VD0/VCCD1	F03	MFUNC2	MFUNC2	J17	CAD7	D7
B06	SC_RSVD	SC_RSVD	F05	MFUNC0	MFUNC0	J18	CRSVD	D14
B07	SC_RSVD	SC_RSVD	F06	CLK_48_RSVD	CLK_48_RSVD	J19	CAD5	D6
B08	CAD29	D1	F07	SC_RSVD	SC_RSVD	K01	GND	GND
B09	$\overline{CCLKRUN}$	WP(IOIS16)	F08	CRSVD	D2	K02	AD29	AD29
B10	CVS1	$\overline{VS1}$	F09	CAD27	D0	K03	AD28	AD28
B11	CC/BE3	$\overline{REG}$	F10	CAUDIO	BVD2(SPKR)	K05	AD27	AD27
B12	$\overline{CREQ}$	$\overline{INPACK}$	F11	CAD26	A0	K06	AD26	AD26
B13	$\overline{CRST}$	RESET	F12	CVS2	$\overline{VS2}$	K14	CAD6	D13
B14	CAD17	A24	F13	$\overline{CIRDY}$	A15	K15	CAD3	D5
B15	$\overline{CFRAME}$	A23	F14	CPAR	A13	K17	CAD4	D12
C05	VD2/VPPD1	VD2/VPPD1	F15	$\overline{CPERR}$	A14	K18	CAD1	D4
C06	SC_RSVD	SC_RSVD	F17	CRSVD	A18	K19	GND	GND
C07	SC_RSVD	SC_RSVD	F18	CAD16	A17	L01	VCCP	VCCP
C08	CAD30	D9	F19	CAD14	A9	L02	AD25	AD25
C09	$\overline{CCD2}$	$\overline{CD2}$	G01	VCC	VCC	L03	AD24	AD24
C10	$\overline{CINT}$	READY( $\overline{IREQ}$ )	G02	VR_PORT	VR_PORT	L05	IDSEL	IDSEL
C11	CAD24	A2	G03	$\overline{SUSPEND}$	$\overline{SUSPEND}$	L06	C/BE3	C/BE3
C12	CAD22	A4	G05	MFUNC4	MFUNC4	L14	CAD2	D11
C13	CAD20	A6	G06	MFUNC1	MFUNC1	L15	CAD0	D3
C14	CC/BE2	A12	G14	VCCCB	VCCCB	L17	$\overline{CCD1}$	$\overline{CD1}$
C15	CCLK	A16	G15	CC/BE1	A8	L18	VR_PORT	VR_PORT
D01	SDA	SDA	G17	CAD15	$\overline{IOWR}$	L19	VCC	VCC
D19	$\overline{CGNT}$	$\overline{WE}$	G18	CAD13	$\overline{IORD}$	M01	VCC	VCC
E01	GND	GND	G19	GND	GND	M02	AD23	AD23
E02	SPKROUT	SPKROUT	H01	PCLK	PCLK	M03	AD22	AD22
E03	SCL	SCL	H02	$\overline{GRST}$	$\overline{GRST}$	M05	AD20	AD20
E05	NC	NC	H03	$\overline{PRST}$	$\overline{PRST}$	M06	AD21	AD21
E06	VD1/VCCD0	VD1/VCCD0	H05	$\overline{VR\_EN}$	$\overline{VR\_EN}$	M14	MC_RSVD	MC_RSVD

**Table 2–2. Signal Names Sorted by GHK Terminal Number (Continued)**

TERM. NO.	SIGNAL NAME		TERM. NO.	SIGNAL NAME		TERM. NO.	SIGNAL NAME	
	CARDBUS	16-BIT		CARDBUS	16-BIT		CARDBUS	16-BIT
M15	MC_RSVD	MC_RSVD	P17	CNA	CNA	U13	ANALOGV <sub>CC</sub>	ANALOGV <sub>CC</sub>
M17	MC_RSVD	MC_RSVD	P18	PHY_TEST_MA	PHY_TEST_MA	U14	ANALOGV <sub>CC</sub>	ANALOGV <sub>CC</sub>
M18	MC_RSVD	MC_RSVD	P19	GND	GND	U15	TPBIAS1	TPBIAS1
M19	MC_RSVD	MC_RSVD	R01	V <sub>CC</sub>	V <sub>CC</sub>	V05	AD13	AD13
N01	GND	GND	R02	DEVSEL	DEVSEL	V06	AD11	AD11
N02	AD19	AD19	R03	PERR	PERR	V07	C/BE0	C/BE0
N03	AD18	AD18	R06	AD15	AD15	V08	AD4	AD4
N05	FRAME	FRAME	R07	AD10	AD10	V09	AD2	AD2
N06	AD17	AD17	R08	AD6	AD6	V10	PC0	PC0
N14	PLLGND	PLLGND	R09	AD0	AD0	V11	TPB0P	TPB0P
N15	MC_RSVD	MC_RSVD	R10	TEST1	TEST1	V12	TPA0P	TPA0P
N17	MC_RSVD	MC_RSVD	R11	ANALOGV <sub>CC</sub>	ANALOGV <sub>CC</sub>	V13	R1	R1
N18	MC_RSVD	MC_RSVD	R12	ANALOGGND	ANALOGGND	V14	TPB1P	TPB1P
N19	MC_RSVD	MC_RSVD	R13	ANALOGGND	ANALOGGND	V15	TPA1P	TPA1P
P01	AD16	AD16	R14	NC	NC	W04	PAR	PAR
P02	C/BE2	C/BE2	R17	FILTER1	FILTER1	W05	V <sub>CCP</sub>	V <sub>CCP</sub>
P03	IRDY	IRDY	R18	XI	XI	W06	GND	GND
P05	STOP	STOP	R19	XO	XO	W07	AD7	AD7
P06	TRDY	TRDY	T01	SERR	SERR	W08	V <sub>CC</sub>	V <sub>CC</sub>
P07	AD14	AD14	T19	FILTER0	FILTER0	W09	AD3	AD3
P08	AD9	AD9	U05	C/BE1	C/BE1	W10	PC1	PC1
P09	PC2	PC2	U06	AD12	AD12	W11	TPB0N	TPB0N
P10	CPS	CPS	U07	AD8	AD8	W12	TPA0N	TPA0N
P11	NC	NC	U08	AD5	AD5	W13	R0	R0
P12	NC	NC	U09	AD1	AD1	W14	TPB1N	TPB1N
P13	NC	NC	U10	TEST0	TEST0	W15	TPA1N	TPA1N
P14	NC	NC	U11	ANALOGGND	ANALOGGND	W16	NC	NC
P15	PLL <sub>VCC</sub>	PLL <sub>VCC</sub>	U12	TPBIAS0	TPBIAS0			

Table 2-3. Signal Names Sorted by RGVF Terminal Number

TERM. NO.	SIGNAL NAME		TERM. NO.	SIGNAL NAME		TERM. NO.	SIGNAL NAME	
	CARDBUS	16-BIT		CARDBUS	16-BIT		CARDBUS	16-BIT
A02	CAUDIO	BVD2(SPKR)	C13	CAD7	D7	H11	VCC	VCC
A03	CVS1	VS1	C14	CAD4	D12	H12	VCC	VCC
A04	CAD25	A1	C15	CCD1	CD1	H13	GND	GND
A05	VCCCB	VCCCB	D01	CAD31	D10	H19	NC	NC
A06	CRST	RESET	D02	CRSVD	D2	J01	SC_RSVD	SC_RSVD
A07	CAD17	A24	D03	CAD29	D1	J02	SC_RSVD	SC_RSVD
A08	CTRDY	A22	D19	NC	NC	J03	SC_RSVD	SC_RSVD
A09	CSTOP	A20	E05	CCD2	CD2	J05	SC_RSVD	SC_RSVD
A10	CAD16	A17	E06	CAD24	A2	J06	MC_RSVD	MC_RSVD
A11	VCCCB	VCCCB	E07	CREQ	INPACK	J07	SC_RSVD	SC_RSVD
A12	CAD9	A10	E08	CVS2	VS2	J08	VCC	VCC
A13	CAD5	D6	E09	CCLK	A16	J09	GND	GND
A14	CAD2	D11	E10	CBLOCK	A19	J10	GND	GND
A18	TEST1	TEST1	E11	CAD15	IOWR	J11	GND	GND
B01	CAD27	D0	E12	CAD8	D15	J12	VCC	VCC
B02	CSTSCHG	BVD1(STSCHG/R)	E13	CAD3	D5	J19	NC	NC
B03	CSERR	WAIT	E14	CAD0	D3	K01	SC_RSVD	SC_RSVD
B04	CAD26	A0	E19	NC	NC	K02	SC_RSVD	SC_RSVD
B05	CAD23	A3	F03	MC_RSVD	MC_RSVD	K08	VCC	VCC
B06	CAD21	A5	F09	CC/BE2	A12	K09	GND	GND
B07	CAD18	A7	F10	CPERR	A14	K10	GND	GND
B08	CIRDY	A15	F12	CAD6	D13	K11	GND	GND
B09	CGNT	WE	F19	NC	NC	K12	VCC	VCC
B10	CC/BE1	A8	G01	MC_RSVD	MC_RSVD	K19	NC	NC
B11	CAD12	A11	G02	MC_RSVD	MC_RSVD	L05	VD0/VCCD1	VD0/VCCD1
B12	CAD10	CE2	G03	MC_RSVD	MC_RSVD	L06	VD1/VCCD0	VD1/VCCD0
B13	CRSVD	D14	G05	MC_RSVD	MC_RSVD	L07	SPKROUT	SPKROUT
B14	CAD1	D4	G07	GND	GND	L08	GND	GND
B18	NC	NC	G08	GND	GND	L09	GND	GND
B19	NC	NC	G09	CAD20	A6	L10	GND	GND
C01	CAD30	D9	G10	CPAR	A13	L11	GND	GND
C02	CAD28	D8	G11	CAD14	A9	L12	GND	GND
C03	CCLKRUN	WP(IOIS16)	G12	CC/BE0	CE1	L19	NC	NC
C04	CINT	READY(IREQ)	G13	GND	GND	M01	CLK_48	CLK_48
C05	CC/BE3	REG	H01	VR_PORT	VR_PORT	M02	SDA	SDA
C06	CAD22	A4	H02	VR_EN	VR_EN	M03	SCL	SCL
C07	CAD19	A25	H03	MC_RSVD	MC_RSVD	M05	MFUNC1	MFUNC1
C08	CFRAME	A23	H05	MC_RSVD	MC_RSVD	M07	VCC	VCC
C09	CDEVSEL	A21	H07	MC_RSVD	MC_RSVD	M08	GND	GND
C10	CRSVD	A18	H08	VCC	VCC	M09	VCC	VCC
C11	CAD13	IORD	H09	VCC	VCC	M10	VCC	VCC
C12	CAD11	OE	H10	VCC	VCC	M11	CPS	CPS

Table 2-3. Signal Names Sorted by RGVF Terminal Number (Continued)

TERM. NO.	SIGNAL NAME		TERM. NO.	SIGNAL NAME		TERM. NO.	SIGNAL NAME	
	CARDBUS	16-BIT		CARDBUS	16-BIT		CARDBUS	16-BIT
M12	V <sub>CC</sub>	V <sub>CC</sub>	R13	ANALOGV <sub>CC</sub>	ANALOGV <sub>CC</sub>	V05	AD23	AD23
M19	VR_PORT	VR_PORT	R14	ANALOGV <sub>CC</sub>	ANALOGV <sub>CC</sub>	V06	AD18	AD18
N01	VD2/VPPD1	VD2/VPPD1	R17	PHY_TEST_MA	PHY_TEST_MA	V07	$\overline{\text{FRAME}}$	$\overline{\text{FRAME}}$
N02	VD3/VPPD0	VD3/VPPD0	R18	XI	XI	V08	$\overline{\text{PERR}}$	$\overline{\text{PERR}}$
N03	MFUNC0	MFUNC0	R19	XO	XO	V09	AD15	AD15
N05	MFUNC5	MFUNC5	T01	$\overline{\text{GRST}}$	$\overline{\text{GRST}}$	V10	AD11	AD11
N07	V <sub>CC</sub>	V <sub>CC</sub>	T02	$\overline{\text{GNT}}$	$\overline{\text{GNT}}$	V11	AD7	AD7
N08	$\overline{\text{DEVSEL}}$	$\overline{\text{DEVSEL}}$	T03	$\overline{\text{RI\_OUT/PME}}$	$\overline{\text{RI\_OUT/PME}}$	V12	AD3	AD3
N09	AD12	AD12	T18	FILTER0	FILTER0	V13	PC2	PC2
N10	AD8	AD8	T19	FILTER1	FILTER1	V14	TPB0P	TPB0P
N11	AD1	AD1	U01	$\overline{\text{REQ}}$	$\overline{\text{REQ}}$	V15	TPA0P	TPA0P
N12	ANALOGGND	ANALOGGND	U02	AD31	AD31	V16	TPB1P	TPB1P
N19	NC	NC	U03	AD28	AD28	V17	ANALOGV <sub>CC</sub>	ANALOGV <sub>CC</sub>
P01	MFUNC2	MFUNC2	U04	AD25	AD25	V18	TPA1P	TPA1P
P02	MFUNC3	MFUNC3	U05	AD22	AD22	V19	PLLV <sub>CC</sub>	PLLV <sub>CC</sub>
P03	MFUNC4	MFUNC4	U06	AD17	AD17	W02	AD27	AD27
P05	PCLK	PCLK	U07	$\overline{\text{IRDY}}$	$\overline{\text{IRDY}}$	W03	V <sub>CCP</sub>	V <sub>CCP</sub>
P06	AD20	AD20	U08	$\overline{\text{SERR}}$	$\overline{\text{SERR}}$	W04	$\overline{\text{C/BE3}}$	$\overline{\text{C/BE3}}$
P09	PAR	PAR	U09	AD14	AD14	W05	IDSEL	IDSEL
P12	TEST0	TEST0	U10	AD10	AD10	W06	AD19	AD19
P14	PLLGND	PLLGND	U11	AD6	AD6	W07	$\overline{\text{C/BE2}}$	$\overline{\text{C/BE2}}$
P15	CNA	CNA	U12	AD2	AD2	W08	$\overline{\text{STOP}}$	$\overline{\text{STOP}}$
P19	NC	NC	U13	PC1	PC1	W09	$\overline{\text{C/BE1}}$	$\overline{\text{C/BE1}}$
R01	MFUNC6	MFUNC6	U14	ANALOGGND	ANALOGGND	W10	V <sub>CCP</sub>	V <sub>CCP</sub>
R02	$\overline{\text{SUSPEND}}$	$\overline{\text{SUSPEND}}$	U15	TPBIAS0	TPBIAS0	W11	$\overline{\text{C/BE0}}$	$\overline{\text{C/BE0}}$
R03	$\overline{\text{PRST}}$	$\overline{\text{PRST}}$	U16	ANALOGGND	ANALOGGND	W12	AD4	AD4
R06	AD21	AD21	U17	TPBIAS1	TPBIAS1	W13	AD0	AD0
R07	AD16	AD16	U18	R0	R0	W14	TPB0N	TPB0N
R08	$\overline{\text{TRDY}}$	$\overline{\text{TRDY}}$	U19	R1	R1	W15	TPA0N	TPA0N
R09	AD13	AD13	V01	AD30	AD30	W16	TPB1N	TPB1N
R10	AD9	AD9	V02	AD29	AD29	W17	NC	NC
R11	AD5	AD5	V03	AD26	AD26	W18	TPA1N	TPA1N
R12	PC0	PC0	V04	AD24	AD24			

Table 2-4. CardBus PC Card Signal Names Sorted Alphabetically

SIGNAL NAME	TERMINAL NUMBER			SIGNAL NAME	TERMINAL NUMBER			SIGNAL NAME	TERMINAL NUMBER		
	PDV	GHK	RGVF		PDV	GHK	RGVF		PDV	GHK	RGVF
AD0	74	R09	W13	CAD5	133	J19	A13	CGNT	156	D19	B09
AD1	73	U09	N11	CAD6	132	K14	F12	CINT	182	C10	C04
AD2	72	V09	U12	CAD7	135	J17	C13	CIRDY	160	F13	B08
AD3	71	W09	V12	CAD8	136	J14	E12	CLK_48_RSVD	204	F06	M01
AD4	69	V08	W12	CAD9	139	H18	A12	CNA	111	P17	P15
AD5	68	U08	R11	CAD10	140	H17	B12	CPAR	152	F14	G10
AD6	67	R08	U11	CAD11	141	H14	C12	CPERR	154	F15	F10
AD7	66	W07	V11	CAD12	142	H15	B11	CPS	80	P10	M11
AD8	64	U07	N10	CAD13	144	G18	C11	CREQ	173	B12	E07
AD9	63	P08	R10	CAD14	147	F19	G11	CRST	169	B13	A06
AD10	61	R07	U10	CAD15	145	G17	E11	CRSVD	134	F08	B13
AD11	60	V06	V10	CAD16	148	F18	A10	CRSVD	150	F17	C10
AD12	59	U06	N09	CAD17	164	B14	A07	CRSVD	193	J18	D02
AD13	57	V05	R09	CAD18	165	E13	B07	CSERR	183	E10	B03
AD14	56	P07	U09	CAD19	166	A14	C07	CSTOP	155	E17	A09
AD15	55	R06	V09	CAD20	168	C13	G09	CSTSCHG	185	A09	B02
AD16	43	P01	R07	CAD21	171	E12	B06	CTRDY	159	E14	A08
AD17	42	N06	U06	CAD22	172	C12	C06	CVS1	181	B10	A03
AD18	41	N03	V06	CAD23	174	A12	B05	CVS2	167	F12	E08
AD19	40	N02	W06	CAD24	177	C11	E06	DEVSEL	49	R02	N08
AD20	38	M05	P06	CAD25	178	E11	A04	FILTER0	105	T19	T18
AD21	37	M06	R06	CAD26	179	F11	B04	FILTER1	106	R17	T19
AD22	36	M03	U05	CAD27	188	F09	B01	FRAME	45	N05	V07
AD23	35	M02	V05	CAD28	189	E09	C02	GNT	19	J01	T02
AD24	31	L03	V04	CAD29	191	B08	D03	GRST	17	H02	T01
AD25	30	L02	U04	CAD30	192	C08	C01	IDSEL	33	L05	W05
AD26	28	K06	V03	CAD31	194	E08	D01	IRDY	46	P03	U07
AD27	27	K05	W02	CAUDIO	184	F10	A02	MC_RSVD	113	N15	H07
AD28	26	K03	U03	C/BE0	65	V07	W11	MC_RSVD	115	M14	G05
AD29	25	K02	V02	C/BE1	54	U05	W09	MC_RSVD	116	N17	G03
AD30	23	J06	V01	C/BE2	44	P02	W07	MC_RSVD	117	N18	H03
AD31	22	J05	U02	C/BE3	32	L06	W04	MC_RSVD	118	N19	G02
ANALOGGND	83	U11	N12	CBLOCK	153	E18	E10	MC_RSVD	119	M15	J06
ANALOGGND	90	R12	U14	CC/BE0	137	J15	G12	MC_RSVD	120	M17	H05
ANALOGGND	97	R13	U16	CC/BE1	149	G15	B10	MC_RSVD	121	M18	F03
ANALOGVCC	85	R11	R13	CC/BE2	163	C14	F09	MC_RSVD	122	M19	G01
ANALOGVCC	93	U13	R14	CC/BE3	176	B11	C05	MFUNC0	3	F05	N03
ANALOGVCC	98	U14	V17	CCD1	125	L17	C15	MFUNC1	4	G06	M05
CAD0	126	L15	E14	CCD2	187	C09	E05	MFUNC2	7	F03	P01
CAD1	129	K18	B14	CCLK	158	C15	E09	MFUNC3	8	F02	P02
CAD2	127	L14	A14	CCLKRUN	186	B09	C03	MFUNC4	9	G05	P03
CAD3	131	K15	E13	CDEVSEL	157	A16	C09	MFUNC5	10	F01	N05
CAD4	130	K17	C14	CFRAME	161	B15	C08	MFUNC6	11	H06	R01

**Table 2–4. CardBus PC Card Signal Names Sorted Alphabetically (Continued)**

SIGNAL NAME	TERMINAL NUMBER			SIGNAL NAME	TERMINAL NUMBER			SIGNAL NAME	TERMINAL NUMBER		
	PDV	GHK	RGVF		PDV	GHK	RGVF		PDV	GHK	RGVF
PAR	53	W04	P09	SC_RSVD	199	A06	J05	TPB0P	82	V11	V14
PCLK	18	H01	P05	SC_RSVD	200	B06	J07	TPB1N	95	W14	W16
PC0	77	V10	R12	SC_RSVD	201	E07	K01	TPB1P	96	V14	V16
PC1	76	W10	U13	SC_RSVD	202	C06	K02	$\overline{\text{TRDY}}$	48	P06	R08
PC2	75	P09	V13	SDA	1	D01	M02	V <sub>CCCB</sub>	146	A11	A05
$\overline{\text{PERR}}$	51	R03	V08	$\overline{\text{SERR}}$	52	T01	U08	V <sub>CCCB</sub>	175	G14	A11
PHY_TEST_MA	112	P18	R17	SPKROUT	5	E02	L07	V <sub>CCP</sub>	29	L01	W03
PLLGND	108	N14	P14	$\overline{\text{STOP}}$	50	P05	W08	V <sub>CCP</sub>	58	W05	W10
PLL <sub>VCC</sub>	107	P15	V19	$\overline{\text{SUSPEND}}$	12	G03	R02	VD0/ $\overline{\text{VCCD1}}$	205	B05	L05
$\overline{\text{PRST}}$	16	H03	R03	TEST0	78	U10	P12	VD1/ $\overline{\text{VCCD0}}$	206	E06	L06
REQ	20	J02	U01	TEST1	79	R10	A18	VD2/ $\overline{\text{VPPD1}}$	207	C05	N01
$\overline{\text{RI\_OUT/PME}}$	21	J03	T03	TPA0N	86	W12	W15	VD3/ $\overline{\text{VPPD0}}$	208	A04	N02
R0	91	W13	U18	TPA0P	87	V12	V15	$\overline{\text{VR\_EN}}$	15	H05	H02
R1	92	V13	U19	TPA1N	99	W15	W18	VR_PORT	13	G02	H01
SCL	2	E03	M03	TPA1P	101	V15	V18	VR_PORT	124	L18	M19
SC_RSVD	196	B07	J01	TPBIAS0	88	U12	U15	XI	109	R18	R18
SC_RSVD	197	C07	J02	TPBIAS1	103	U15	U17	XO	110	R19	R19
SC_RSVD	198	F07	J03	TPB0N	81	W11	W14				

Table 2-5. 16-Bit PC Card Signal Names Sorted Alphabetically

SIGNAL NAME	TERMINAL NUMBER			SIGNAL NAME	TERMINAL NUMBER			SIGNAL NAME	TERMINAL NUMBER		
	PDV	GHK	RGVF		PDV	GHK	RGVF		PDV	GHK	RGVF
AD0	74	R09	W13	A5	171	E12	B06	D8	189	E09	C02
AD1	73	U09	N11	A6	168	C13	G09	D9	192	C08	C01
AD2	72	V09	U12	A7	165	E13	B07	D10	194	E08	D01
AD3	71	W09	V12	A8	149	G15	B10	D11	127	L14	A14
AD4	69	V08	W12	A9	147	F19	G11	D12	130	K17	C14
AD5	68	U08	R11	A10	139	H18	A12	D13	132	K14	F12
AD6	67	R08	U11	A11	142	H15	B11	D14	134	J18	B13
AD7	66	W07	V11	A12	163	C14	F09	D15	136	J14	E12
AD8	64	U07	N10	A13	152	F14	G10	FILTER0	105	T19	T18
AD9	63	P08	R10	A14	154	F15	F10	FILTER1	106	R17	T19
AD10	61	R07	U10	A15	160	F13	B08	FRAME	45	N05	V07
AD11	60	V06	V10	A16	158	C15	E09	GNT	19	J01	T02
AD12	59	U06	N09	A17	148	F18	A10	GRST	17	H02	T01
AD13	57	V05	R09	A18	150	F17	C10	IDSEL	33	L05	W05
AD14	56	P07	U09	A19	153	E18	E10	INPACK	173	B12	E07
AD15	55	R06	V09	A20	155	E17	A09	IORD	144	G18	C11
AD16	43	P01	R07	A21	157	A16	C09	IOWR	145	G17	E11
AD17	42	N06	U06	A22	159	E14	A08	IRDY	46	P03	U07
AD18	41	N03	V06	A23	161	B15	C08	MC_RSVD	113	N14	H07
AD19	40	N02	W06	A24	164	B14	A07	MC_RSVD	115	M14	G05
AD20	38	M05	P06	A25	166	A14	C07	MC_RSVD	116	N17	G03
AD21	37	M06	R06	BVD1(STSCHG/RI)	185	A09	B02	MC_RSVD	117	N18	H03
AD22	36	M03	U05	BVD2(SPKR)	184	F10	A02	MC_RSVD	118	N19	G02
AD23	35	M02	V05	C/BE0	65	V07	W11	MC_RSVD	119	M15	J06
AD24	31	L03	V04	C/BE1	54	U05	W09	MC_RSVD	120	M17	H05
AD25	30	L02	U04	C/BE2	44	P02	W07	MC_RSVD	121	M18	F03
AD26	28	K06	V03	C/BE3	32	L06	W04	MC_RSVD	122	M19	G01
AD27	27	K05	W02	CD1	125	L17	C15	MFUNC0	3	F05	N03
AD28	26	K03	U03	CD2	187	C09	E05	MFUNC1	4	G06	M05
AD29	25	K02	V02	CE1	137	J15	G12	MFUNC2	7	F03	P01
AD30	23	J06	V01	CE2	140	H17	B12	MFUNC3	8	F02	P02
AD31	22	J05	U02	CLK_48_RSVD	204	F06	M01	MFUNC4	9	G05	P03
ANALOGGND	83	U11	N12	CNA	111	P17	P15	MFUNC5	10	F01	N05
ANALOGGND	90	R12	U14	CPS	80	P10	M11	MFUNC6	11	H06	R01
ANALOGGND	97	R13	U16	DEVSEL	49	R02	N08	OE	141	H14	C12
ANALOGVCC	85	R11	R13	D0	188	F09	B01	PAR	53	W04	P09
ANALOGVCC	93	U13	R14	D1	191	B08	D03	PCLK	18	H01	P05
ANALOGVCC	98	U14	V17	D2	193	F08	D02	PC0	77	V10	R12
A0	179	F11	B04	D3	126	L15	E14	PC1	76	W10	U13
A1	178	E11	A04	D4	129	K18	B14	PC2	75	P09	V13
A2	177	C11	E06	D5	131	K15	E13	PERR	51	R03	V08
A3	174	A12	B05	D6	133	J19	A13	PHY_TEST_MA	112	P18	R17
A4	172	C12	C06	D7	135	J17	C13	PLLGND	108	N14	P14

**Table 2-5. 16-Bit PC Card Signal Names Sorted Alphabetically (Continued)**

SIGNAL NAME	TERMINAL NUMBER			SIGNAL NAME	TERMINAL NUMBER			SIGNAL NAME	TERMINAL NUMBER		
	PDV	GHK	RGVF		PDV	GHK	RGVF		PDV	GHK	RGVF
PLL $\overline{V_{CC}}$	107	P15	V19	$\overline{SERR}$	52	T01	U08	$V_{CCCB}$	175	G14	A11
$\overline{PRST}$	16	H03	R03	SPKROUT	5	E02	L07	$V_{CCP}$	29	L01	W03
READY( $\overline{IREQ}$ )	182	C10	C04	$\overline{STOP}$	50	P05	W08	$V_{CCP}$	58	W05	W10
$\overline{REG}$	176	B11	C05	$\overline{SUSPEND}$	12	G03	R02	VD0/ $\overline{VCCD1}$	205	B05	L05
$\overline{REQ}$	20	J02	U01	TEST0	78	U10	P12	VD1/ $\overline{VCCD0}$	206	E06	L06
RESET	169	B13	A06	TEST1	79	R10	A18	VD2/ $\overline{VPPD1}$	207	C05	N01
RI_OUT/ $\overline{PME}$	21	J03	T03	TPA0N	86	W12	W15	VD3/ $\overline{VPPD0}$	208	A04	N02
R0	91	W13	U18	TPA0P	87	V12	V15	$\overline{VR\_EN}$	15	H05	H02
R1	92	V13	U19	TPA1N	99	W15	W18	VR_PORT	13	G02	H01
SCL	2	E03	M03	TPA1P	101	V15	V18	VR_PORT	124	L18	M19
SC_RSVD	196	B07	J01	TPBIAS0	88	U12	U15	$\overline{VS1}$	181	B10	A03
SC_RSVD	197	C07	J02	TPBIAS1	103	U15	U17	$\overline{VS2}$	167	F12	E08
SC_RSVD	198	F07	J03	TPB0N	81	W11	W14	$\overline{WAIT}$	183	E10	B03
SC_RSVD	199	A06	J05	TPB0P	82	V11	V14	$\overline{WE}$	156	D19	B09
SC_RSVD	200	B06	J07	TPB1N	95	W14	W16	WP( $\overline{IOIS16}$ )	186	B09	C03
SC_RSVD	201	E07	K01	TPB1P	96	V14	V16	XI	109	R18	R18
SC_RSVD	202	C06	K02	$\overline{TRDY}$	48	P06	R08	XO	110	R19	R19
SDA	1	D01	M02	$V_{CCCB}$	146	A11	A05				



The terminals are grouped in tables by functionality, such as PCI system function, power-supply function, etc. The terminal numbers are also listed for convenient reference.

**Table 2–6. Power Supply Terminals**

TERMINAL				I/O	DESCRIPTION
NAME	NUMBER				
	PDV	GHK	RGVF		
GND	6, 24, 39, 62, 114, 128, 143, 162, 180, 195	E01, K01, N01, W06, P19, K19, G19, A15, A10, A07	G07, G08, G13, H13, J09, J10, J11, K09, K10, K11, L08, L09, L10, L11, L12, M08	–	Device ground terminals
VCC	14, 34, 47, 70, 123, 138, 151, 170, 190, 203	G01, M01, R01, W08, L19, H19, E19, A13, A08, A05	H08, H09, H10, H11, H12, J08, J12, K08, K12, M07, M09, M10, M12, N07	–	Power supply terminal for I/O and internal voltage regulator
VCCCB	146, 175	G14, A11	A05, A11	–	Clamp voltage for PC CardBus interface. Matches card signaling environment, 5 V or 3.3 V
VCCP	29, 58	L01, W05	W03, W10	–	Clamp voltage for PCI and miscellaneous I/O, 5 V or 3.3 V
VR_EN	15	H05	H02	I	Internal voltage regulator enable. Active low
VR_PORT	13, 124	G02, L18	H01, M19	I/O	Internal voltage regulator input/output. When $\overline{\text{VR\_EN}}$ is low, the regulator is enabled and these terminals are outputs. The two VR_PORT terminals must be tied together and connected to ground through a 0.1 $\mu\text{F}$ bypass capacitor. When $\overline{\text{VR\_EN}}$ is high, the regulator is disabled and these terminals are inputs for an external 1.8-V core power source.

**Table 2–7. PC Card Power Switch Terminals**

TERMINAL				I/O	DESCRIPTION
NAME	NUMBER				
	PDV	GHK	RGVF		
$\overline{\text{VD1/VCCD0}}$ $\overline{\text{VD0/VCCD1}}$	206 205	E06 B05	L06 L05	O	Logic controls to the TPS2211A or TPS2221 PC Card power interface switch to control AVCC
$\overline{\text{VD3/VPPD0}}$ $\overline{\text{VD2/VPPD1}}$	208 207	A04 C05	N02 N01	O	Logic controls to the TPS2211A or TPS2221 PC Card power interface switch to control AVpp

**Table 2–8. PCI System Terminals**

TERMINAL				I/O	DESCRIPTION
NAME	NUMBER				
	PDV	GHK	RGVF		
$\overline{\text{GRST}}$	17	H02	T01	I	Global reset. When the global reset is asserted, the $\overline{\text{GRST}}$ signal causes the PCI4510 device to place all output buffers in a high-impedance state and reset all internal registers. When $\overline{\text{GRST}}$ is asserted, the device is completely in its default state. $\overline{\text{GRST}}$ must be connected to POWER_OK.
PCLK	18	H01	P05	I	PCI bus clock. PCLK provides timing for all transactions on the PCI bus. All PCI signals are sampled at the rising edge of PCLK.
$\overline{\text{PRST}}$	16	H03	R03	I	PCI bus reset. When the PCI bus reset is asserted, $\overline{\text{PRST}}$ causes the PCI4510 device to place all output buffers in a high-impedance state and reset internal registers. When $\overline{\text{PRST}}$ is asserted, the device is completely nonfunctional. After $\overline{\text{PRST}}$ is deasserted, the PCI4510 device is in a default state. When $\overline{\text{SUSPEND}}$ and $\overline{\text{PRST}}$ are asserted, the device is protected from $\overline{\text{PRST}}$ clearing the internal registers. All outputs are placed in a high-impedance state, but the contents of the registers are preserved.

Table 2–9. PCI Address and Data Terminals

TERMINAL				I/O	DESCRIPTION
NAME	NUMBER				
	PDV	GHK	RGVF		
AD31	22	J05	U02	I/O	PCI address/data bus. These signals make up the multiplexed PCI address and data bus on the primary interface. During the address phase of a primary-bus PCI cycle, AD31–AD0 contain a 32-bit address or other destination information. During the data phase, AD31–AD0 contain data.
AD30	23	J06	V01		
AD29	25	K02	V02		
AD28	26	K03	U03		
AD27	27	K05	W02		
AD26	28	K06	V03		
AD25	30	L02	U04		
AD24	31	L03	V04		
AD23	35	M02	V05		
AD22	36	M03	U05		
AD21	37	M06	R06		
AD20	38	M05	P06		
AD19	40	N02	W06		
AD18	41	N03	V06		
AD17	42	N06	U06		
AD16	43	P01	R07		
AD15	55	R06	V09		
AD14	56	P07	U09		
AD13	57	V05	R09		
AD12	59	U06	N09		
AD11	60	V06	V10		
AD10	61	R07	U10		
AD9	63	P08	R10		
AD8	64	U07	N10		
AD7	66	W07	V11		
AD6	67	R08	U11		
AD5	68	U08	R11		
AD4	69	V08	W12		
AD3	71	W09	V12		
AD2	72	V09	U12		
AD1	73	U09	N11		
AD0	74	R09	W13		
$\overline{C/BE3}$	32	L06	W04	I/O	PCI-bus commands and byte enables. These signals are multiplexed on the same PCI terminals. During the address phase of a primary-bus PCI cycle, $\overline{C/BE3}$ – $\overline{C/BE0}$ define the bus command. During the data phase, this 4-bit bus is used as byte enables. The byte enables determine which byte paths of the full 32-bit data bus carry meaningful data. $\overline{C/BE0}$ applies to byte 0 (AD7–AD0), $\overline{C/BE1}$ applies to byte 1 (AD15–AD8), $\overline{C/BE2}$ applies to byte 2 (AD23–AD16), and $\overline{C/BE3}$ applies to byte 3 (AD31–AD24).
$\overline{C/BE2}$	44	P02	W07		
$\overline{C/BE1}$	54	U05	W09		
$\overline{C/BE0}$	65	V07	W11		
PAR	53	W04	P09	I/O	PCI-bus parity. In all PCI-bus read and write cycles, the PCI4510 device calculates even parity across the AD31–AD0 and $\overline{C/BE3}$ – $\overline{C/BE0}$ buses. As an initiator during PCI cycles, the PCI4510 device outputs this parity indicator with a one-PCLK delay. As a target during PCI cycles, the PCI4510 device compares its calculated parity to the parity indicator of the initiator. A compare error results in the assertion of a parity error ( $\overline{PERR}$ ).

**Table 2–10. PCI Interface Control Terminals**

TERMINAL				I/O	DESCRIPTION
NAME	NUMBER				
	PDV	GHK	RGVF		
$\overline{\text{DEVSEL}}$	49	R02	N08	I/O	PCI device select. The PCI4510 device asserts $\overline{\text{DEVSEL}}$ to claim a PCI cycle as the target device. As a PCI initiator on the bus, the PCI4510 device monitors $\overline{\text{DEVSEL}}$ until a target responds. If no target responds before timeout occurs, then the PCI4510 device terminates the cycle with an initiator abort.
$\overline{\text{FRAME}}$	45	N05	V07	I/O	PCI cycle frame. $\overline{\text{FRAME}}$ is driven by the initiator of a bus cycle. $\overline{\text{FRAME}}$ is asserted to indicate that a bus transaction is beginning, and data transfers continue while this signal is asserted. When $\overline{\text{FRAME}}$ is deasserted, the PCI bus transaction is in the final data phase.
$\overline{\text{GNT}}$	19	J01	T02	I	PCI bus grant. $\overline{\text{GNT}}$ is driven by the PCI bus arbiter to grant the PCI4510 device access to the PCI bus after the current data transaction has completed. $\overline{\text{GNT}}$ may or may not follow a PCI bus request, depending on the PCI bus parking algorithm.
IDSEL	33	L05	W05	I	Initialization device select. IDSEL selects the PCI4510 device during configuration space accesses. IDSEL can be connected to one of the upper 24 PCI address lines on the PCI bus.
$\overline{\text{IRDY}}$	46	P03	U07	I/O	PCI initiator ready. $\overline{\text{IRDY}}$ indicates the ability of the PCI bus initiator to complete the current data phase of the transaction. A data phase is completed on a rising edge of PCLK where both $\overline{\text{IRDY}}$ and $\overline{\text{TRDY}}$ are asserted. Until $\overline{\text{IRDY}}$ and $\overline{\text{TRDY}}$ are both sampled asserted, wait states are inserted.
$\overline{\text{PERR}}$	51	R03	V08	I/O	PCI parity error indicator. $\overline{\text{PERR}}$ is driven by a PCI device to indicate that calculated parity does not match PAR when $\overline{\text{PERR}}$ is enabled through bit 6 of the command register (PCI offset 04h, see Section 4.4).
$\overline{\text{REQ}}$	20	J02	U01	O	PCI bus request. $\overline{\text{REQ}}$ is asserted by the PCI4510 device to request access to the PCI bus as an initiator.
$\overline{\text{SERR}}$	52	T01	U08	O	PCI system error. $\overline{\text{SERR}}$ is an output that is pulsed from the PCI4510 device when enabled through bit 8 of the command register (PCI offset 04h, see Section 4.4) indicating a system error has occurred. The PCI4510 device need not be the target of the PCI cycle to assert this signal. When $\overline{\text{SERR}}$ is enabled in the command register, this signal also pulses, indicating that an address parity error has occurred on a CardBus interface.
$\overline{\text{STOP}}$	50	P05	W08	I/O	PCI cycle stop signal. $\overline{\text{STOP}}$ is driven by a PCI target to request the initiator to stop the current PCI bus transaction. $\overline{\text{STOP}}$ is used for target disconnects and is commonly asserted by target devices that do not support burst data transfers.
$\overline{\text{TRDY}}$	48	P06	R08	I/O	PCI target ready. $\overline{\text{TRDY}}$ indicates the ability of the primary bus target to complete the current data phase of the transaction. A data phase is completed on a rising edge of PCLK when both $\overline{\text{IRDY}}$ and $\overline{\text{TRDY}}$ are asserted. Until both $\overline{\text{IRDY}}$ and $\overline{\text{TRDY}}$ are asserted, wait states are inserted.

**Table 2–11. Multifunction and Miscellaneous Terminals**

TERMINAL				I/O	DESCRIPTION
NAME	NUMBER				
	PDV	GHK	RGVF		
CLK_48_RSVD	204	F06	M01	–	Reserved for future 48-MHz clock terminal
MFUNC0	3	F05	N03	I/O	Multifunction terminal 0. See Section 4.34, <i>Multifunction Routing Register</i> , for configuration details.
MFUNC1	4	G06	M05	I/O	Multifunction terminal 1. See Section 4.34, <i>Multifunction Routing Register</i> , for configuration details.
MFUNC2	7	F03	P01	I/O	Multifunction terminal 2. See Section 4.34, <i>Multifunction Routing Register</i> , for configuration details.
MFUNC3	8	F02	P02	I/O	Multifunction terminal 3. See Section 4.34, <i>Multifunction Routing Register</i> , for configuration details.
MFUNC4	9	G05	P03	I/O	Multifunction terminal 4. See Section 4.34, <i>Multifunction Routing Register</i> , for configuration details.
MFUNC5	10	F01	N05	I/O	Multifunction terminal 5. See Section 4.34, <i>Multifunction Routing Register</i> , for configuration details.
MFUNC6	11	H06	R01	I/O	Multifunction terminal 6. See Section 4.34, <i>Multifunction Routing Register</i> , for configuration details.
NC	— 84, 89, 94, 100, 102, 104	E05 P11, P12, P13, P14, R14, W16	B18, B19, D19, E19, F19, H19, J19, K19, L19, N19, P19, W17		No connect. These terminals have no connection anywhere within the package. Terminal E05 on the GHK package is used as a key to indicate the location of the A01 corner of the BGA package.
PHY_TEST_MA	112	P18	R17	I	PHY test pin. Not for customer use. It must be pulled high with a 4.7-k $\Omega$ resistor.
$\overline{\text{RI\_OUT/PME}}$	21	J03	T03	O	Ring indicate out and power management event output. This terminal provides an output for ring-indicate or PME signals.
SCL	2	E03	M03	I/O	Serial clock. This terminal provides the serial clock signaling and is implemented as open-drain. For normal operation (a ROM is implemented in the design), this terminal must be pulled high to the ROM $V_{DD}$ with a 2.7-k $\Omega$ resistor. Otherwise, it must be pulled low to ground with a 220- $\Omega$ resistor.
SDA	1	D01	M02	I/O	Serial data. At $\overline{\text{GRST}}$ , the SDA signal is sampled to determine if a two-wire serial ROM is present. If the serial ROM is detected, then this terminal provides the serial data signaling.  This terminal is implemented as open-drain, and for normal operation (a ROM is implemented in the design), this terminal must be pulled high to the ROM $V_{DD}$ with a 2.7-k $\Omega$ resistor. Otherwise, it must be pulled low to ground with a 220- $\Omega$ resistor.
SPKROUT	5	E02	L07	O	Speaker output. SPKROUT is the output to the host system that can carry SPKR or CAUDIO through the PCI4510 device from the PC Card interface.
$\overline{\text{SUSPEND}}$	12	G03	R02	I	Suspend. $\overline{\text{SUSPEND}}$ protects the internal registers from clearing when the $\overline{\text{GRST}}$ or $\overline{\text{PRST}}$ signal is asserted. See Section 3.8.6, <i>Suspend Mode</i> , for details.
TEST0 TEST1	78 79	U10 R10	P12 A18	I/O	Terminals TEST[1, 0] are used for factory test of the device and must be connected to ground for normal operation.

**Table 2–12. 16-Bit PC Card Address and Data Terminals**

TERMINAL				I/O	DESCRIPTION
NAME	NUMBER				
	PDV	GHK	RGVF		
A25	166	A14	C07	O	PC Card address. 16-bit PC Card address lines. A25 is the most significant bit.
A24	164	B14	A07		
A23	161	B15	C08		
A22	159	E14	A08		
A21	157	A16	C09		
A20	155	E17	A09		
A19	153	E18	E10		
A18	150	F17	C10		
A17	148	F18	A10		
A16	158	C15	E09		
A15	160	F13	B08		
A14	154	F15	F10		
A13	152	F14	G10		
A12	163	C14	F09		
A11	142	H15	B11		
A10	139	H18	A12		
A9	147	F19	G11		
A8	149	G15	B10		
A7	165	E13	B07		
A6	168	C13	G09		
A5	171	E12	B06		
A4	172	C12	C06		
A3	174	A12	B05		
A2	177	C11	E06		
A1	178	E11	A04		
A0	179	F11	B04		
D15	136	J14	E12	I/O	PC Card data. 16-bit PC Card data lines. D15 is the most significant bit.
D14	134	J18	B13		
D13	132	K14	F12		
D12	130	K17	C14		
D11	127	L14	A14		
D10	194	E08	D01		
D9	192	C08	C01		
D8	189	E09	C02		
D7	135	J17	C13		
D6	133	J19	A13		
D5	131	K15	E13		
D4	129	K18	B14		
D3	126	L15	E14		
D2	193	F08	D02		
D1	191	B08	D03		
D0	188	F09	B01		

**Table 2–13. 16-Bit PC Card Interface Control Terminals**

TERMINAL				I/O	DESCRIPTION
NAME	NUMBER				
	PDV	GHK	RGVF		
$\overline{\text{BVD1}}$ ( $\overline{\text{STSCHG/RI}}$ )	185	A09	B02	I	Battery voltage detect 1. BVD1 is generated by 16-bit memory PC Cards that include batteries. BVD1 is used with BVD2 as an indication of the condition of the batteries on a memory PC Card. Both BVD1 and BVD2 are high when the battery is good. When BVD2 is low and BVD1 is high, the battery is weak and must be replaced. When BVD1 is low, the battery is no longer serviceable and the data in the memory PC Card is lost. See Section 5.6, <i>ExCA Card Status-Change Interrupt Configuration Register</i> , for enable bits. See Section 5.5, <i>ExCA Card Status-Change Register</i> , and Section 5.2, <i>ExCA Interface Status Register</i> , for the status bits for this signal.  Status change. $\overline{\text{STSCHG}}$ is used to alert the system to a change in the READY, write protect, or battery voltage dead condition of a 16-bit I/O PC Card.  Ring indicate. $\overline{\text{RI}}$ is used by 16-bit modem cards to indicate a ring detection.
$\overline{\text{BVD2}}$ ( $\overline{\text{SPKR}}$ )	184	F10	A02	I	Battery voltage detect 2. BVD2 is generated by 16-bit memory PC Cards that include batteries. BVD2 is used with BVD1 as an indication of the condition of the batteries on a memory PC Card. Both BVD1 and BVD2 are high when the battery is good. When BVD2 is low and BVD1 is high, the battery is weak and must be replaced. When BVD1 is low, the battery is no longer serviceable and the data in the memory PC Card is lost. See Section 5.6, <i>ExCA Card Status-Change Interrupt Configuration Register</i> , for enable bits. See Section 5.5, <i>ExCA Card Status-Change Register</i> , and Section 5.2, <i>ExCA Interface Status Register</i> , for the status bits for this signal.  Speaker. $\overline{\text{SPKR}}$ is an optional binary audio signal available only when the card and socket have been configured for the 16-bit I/O interface. The audio signals from cards A and B are combined by the PCI4510 device and are output on SPKROUT.
$\overline{\text{CD1}}$ $\overline{\text{CD2}}$	125 187	L17 C09	C15 E05	I	Card detect 1 and card detect 2. $\overline{\text{CD1}}$ and $\overline{\text{CD2}}$ are internally connected to ground on the PC Card. When a PC Card is inserted into a socket, $\overline{\text{CD1}}$ and $\overline{\text{CD2}}$ are pulled low. For signal status, see Section 5.2, <i>ExCA Interface Status Register</i> .
$\overline{\text{CE1}}$ $\overline{\text{CE2}}$	137 140	J15 H17	G12 B12	O	Card enable 1 and card enable 2. $\overline{\text{CE1}}$ and $\overline{\text{CE2}}$ enable even- and odd-numbered address bytes. $\overline{\text{CE1}}$ enables even-numbered address bytes, and $\overline{\text{CE2}}$ enables odd-numbered address bytes.
INPACK	173	B12	E07	I	Input acknowledge. $\overline{\text{INPACK}}$ is asserted by the PC Card when it can respond to an I/O read cycle at the current address.
IORD	144	G18	C11	O	I/O read. $\overline{\text{IORD}}$ is asserted by the PCI4510 device to enable 16-bit I/O PC Card data output during host I/O read cycles.
$\overline{\text{IOWR}}$	145	G17	E11	O	I/O write. $\overline{\text{IOWR}}$ is driven low by the PCI4510 device to strobe write data into 16-bit I/O PC Cards during host I/O write cycles.
OE	141	H14	C12	O	Output enable. $\overline{\text{OE}}$ is driven low by the PCI4510 device to enable 16-bit memory PC Card data output during host memory read cycles.
READY ( $\overline{\text{IREQ}}$ )	182	C10	C04	I	Ready. The ready function is provided by READY when the 16-bit PC Card and the host socket are configured for the memory-only interface. READY is driven low by 16-bit memory PC Cards to indicate that the memory card circuits are busy processing a previous write command. READY is driven high when the 16-bit memory PC Card is ready to accept a new data transfer command.  Interrupt request. $\overline{\text{IREQ}}$ is asserted by a 16-bit I/O PC Card to indicate to the host that a device on the 16-bit I/O PC Card requires service by the host software. $\overline{\text{IREQ}}$ is high (deasserted) when no interrupt is requested.
REG	176	B11	C05	O	Attribute memory select. $\overline{\text{REG}}$ remains high for all common memory accesses. When $\overline{\text{REG}}$ is asserted, access is limited to attribute memory ( $\overline{\text{OE}}$ or $\overline{\text{WE}}$ active) and to the I/O space ( $\overline{\text{IORD}}$ or $\overline{\text{IOWR}}$ active). Attribute memory is a separately accessed section of card memory and is generally used to record card capacity and other configuration and attribute information.
RESET	169	B13	A06	O	PC Card reset. RESET forces a hard reset to a 16-bit PC Card.

**Table 2–13. 16-Bit PC Card Interface Control Terminals (Continued)**

TERMINAL				I/O	DESCRIPTION
NAME	NUMBER				
	PDV	GHK	RGVF		
$\overline{VS1}$ $\overline{VS2}$	181 167	B10 F12	A03 E08	I/O	Voltage sense 1 and voltage sense 2. $\overline{VS1}$ and $\overline{VS2}$ , when used in conjunction with each other, determine the operating voltage of the PC Card.
WAIT	183	E10	B03	I	Bus cycle wait. $\overline{WAIT}$ is driven by a 16-bit PC Card to extend the completion of the memory or I/O cycle in progress.
WE	156	D19	B09	O	Write enable. $\overline{WE}$ is used to strobe memory write data into 16-bit memory PC Cards. $\overline{WE}$ is also used for memory PC Cards that employ programmable memory technologies.
$\overline{WP}$ (IOIS16)	186	B09	C03	I	Write protect. $\overline{WP}$ applies to 16-bit memory PC Cards. $\overline{WP}$ reflects the status of the write-protect switch on 16-bit memory PC Cards. For 16-bit I/O cards, $\overline{WP}$ is used for the 16-bit port (IOIS16) function. I/O is 16 bits. $\overline{IOIS16}$ applies to 16-bit I/O PC Cards. $\overline{IOIS16}$ is asserted by the 16-bit PC Card when the address on the bus corresponds to an address to which the 16-bit PC Card responds, and the I/O port that is addressed is capable of 16-bit accesses.

**Table 2–14. CardBus PC Card Interface System Terminals**

TERMINAL				I/O	DESCRIPTION
NAME	NUMBER				
	PDV	GHK	RGVF		
CCLK	158	C15	E09	O	CardBus clock. CCLK provides synchronous timing for all transactions on the CardBus interface. All signals except $\overline{CRST}$ , $\overline{CCLKRUN}$ , $\overline{CINT}$ , $\overline{CSTSCHG}$ , $\overline{CAUDIO}$ , $\overline{CCD2}$ , $\overline{CCD1}$ , $\overline{CVS2}$ , and $\overline{CVS1}$ are sampled on the rising edge of CCLK, and all timing parameters are defined with the rising edge of this signal. CCLK operates at the PCI bus clock frequency, but it can be stopped in the low state or slowed down for power savings.
$\overline{CCLKRUN}$	186	B09	C03	I/O	CardBus clock run. $\overline{CCLKRUN}$ is used by a CardBus PC Card to request an increase in the CCLK frequency, and by the PCI4510 device to indicate that the CCLK frequency is going to be decreased.
$\overline{CRST}$	169	B13	A06	O	CardBus reset. $\overline{CRST}$ brings CardBus PC Card-specific registers, sequencers, and signals to a known state. When $\overline{CRST}$ is asserted, all CardBus PC Card signals are placed in a high-impedance state, and the PCI4510 device drives these signals to a valid logic level. Assertion can be asynchronous to CCLK, but deassertion must be synchronous to CCLK.

Table 2–15. CardBus PC Card Address and Data Terminals

TERMINAL				I/O	DESCRIPTION
NAME	NUMBER				
	PDV	GHK	RGVF		
CAD31	194	E08	D01	I/O	CardBus address and data. These signals make up the multiplexed CardBus address and data bus on the CardBus interface. During the address phase of a CardBus cycle, CAD31–CAD0 contain a 32-bit address. During the data phase of a CardBus cycle, CAD31–CAD0 contain data. CAD31 is the most significant bit.
CAD30	192	C08	C01		
CAD29	191	B08	D03		
CAD28	189	E09	C02		
CAD27	188	F09	B01		
CAD26	179	F11	B04		
CAD25	178	E11	A04		
CAD24	177	C11	E06		
CAD23	174	A12	B05		
CAD22	172	C12	C06		
CAD21	171	E12	B06		
CAD20	168	C13	G09		
CAD19	166	A14	C07		
CAD18	165	E13	B07		
CAD17	164	B14	A07		
CAD16	148	F18	A10		
CAD15	145	G17	E11		
CAD14	147	F19	G11		
CAD13	144	G18	C11		
CAD12	142	H15	B11		
CAD11	141	H14	C12		
CAD10	140	H17	B12		
CAD9	139	H18	A12		
CAD8	136	J14	E12		
CAD7	135	J17	C13		
CAD6	132	K14	F12		
CAD5	133	J19	A13		
CAD4	130	K17	C14		
CAD3	131	K15	E13		
CAD2	127	L14	A14		
CAD1	129	K18	B14		
CAD0	126	L15	E14		
CC/BE3 CC/BE2 CC/BE1 CC/BE0	176 163 149 137	B11 C14 G15 J15	C05 F09 B10 G12	I/O	CardBus bus commands and byte enables. CC/BE3–CC/BE0 are multiplexed on the same CardBus terminals. During the address phase of a CardBus cycle, CC/BE3–CC/BE0 define the bus command. During the data phase, this 4-bit bus is used as byte enables. The byte enables determine which byte paths of the full 32-bit data bus carry meaningful data. CC/BE0 applies to byte 0 (CAD7–CAD0), CC/BE1 applies to byte 1 (CAD15–CAD8), CC/BE2 applies to byte 2 (CAD23–CAD16), and CC/BE3 applies to byte 3 (CAD31–CAD24).
CPAR	152	F14	G10	I/O	CardBus parity. In all CardBus read and write cycles, the PCI4510 device calculates even parity across the CAD and CC/BE buses. As an initiator during CardBus cycles, the PCI4510 device outputs CPAR with a one-CCLK delay. As a target during CardBus cycles, the PCI4510 device compares its calculated parity to the parity indicator of the initiator; a compare error results in a parity error assertion.



**Table 2–16. CardBus PC Card Interface Control Terminals**

TERMINAL				I/O	DESCRIPTION
NAME	NUMBER				
	PDV	GHK	RGVF		
CAUDIO	184	F10	A02	I	CardBus audio. CAUDIO is a digital input signal from a PC Card to the system speaker. The PCI4510 device supports the binary audio mode and outputs a binary signal from the card to SPKROUT.
CBLOCK	153	E18	E10	I/O	CardBus lock. $\overline{\text{CBLOCK}}$ is used to gain exclusive access to a target.
CCD1 CCD2	125 187	L17 C09	C15 E05	I	CardBus detect 1 and CardBus detect 2. $\overline{\text{CCD1}}$ and $\overline{\text{CCD2}}$ are used in conjunction with CVS1 and CVS2 to identify card insertion and interrogate cards to determine the operating voltage and card type.
$\overline{\text{CDEVSEL}}$	157	A16	C09	I/O	CardBus device select. The PCI4510 device asserts $\overline{\text{CDEVSEL}}$ to claim a CardBus cycle as the target device. As a CardBus initiator on the bus, the PCI4510 device monitors $\overline{\text{CDEVSEL}}$ until a target responds. If no target responds before timeout occurs, then the PCI4510 device terminates the cycle with an initiator abort.
$\overline{\text{CFRAME}}$	161	B15	C08	I/O	CardBus cycle frame. $\overline{\text{CFRAME}}$ is driven by the initiator of a CardBus bus cycle. $\overline{\text{CFRAME}}$ is asserted to indicate that a bus transaction is beginning, and data transfers continue while this signal is asserted. When $\overline{\text{CFRAME}}$ is deasserted, the CardBus bus transaction is in the final data phase.
$\overline{\text{CGNT}}$	156	D19	B09	O	CardBus bus grant. $\overline{\text{CGNT}}$ is driven by the PCI4510 device to grant a CardBus PC Card access to the CardBus bus after the current data transaction has been completed.
$\overline{\text{CINT}}$	182	C10	C04	I	CardBus interrupt. $\overline{\text{CINT}}$ is asserted low by a CardBus PC Card to request interrupt servicing from the host.
$\overline{\text{CIRDY}}$	160	F13	B08	I/O	CardBus initiator ready. $\overline{\text{CIRDY}}$ indicates the ability of the CardBus initiator to complete the current data phase of the transaction. A data phase is completed on a rising edge of CCLK when both $\overline{\text{CIRDY}}$ and $\overline{\text{CTRDY}}$ are asserted. Until $\overline{\text{CIRDY}}$ and $\overline{\text{CTRDY}}$ are both sampled asserted, wait states are inserted.
$\overline{\text{CPERR}}$	154	F15	F10	I/O	CardBus parity error. $\overline{\text{CPERR}}$ reports parity errors during CardBus transactions, except during special cycles. It is driven low by a target two clocks following the data cycle during which a parity error is detected.
$\overline{\text{CREQ}}$	173	B12	E07	I	CardBus request. $\overline{\text{CREQ}}$ indicates to the arbiter that the CardBus PC Card desires use of the CardBus bus as an initiator.
$\overline{\text{CSERR}}$	183	E10	B03	I	CardBus system error. $\overline{\text{CSERR}}$ reports address parity errors and other system errors that could lead to catastrophic results. $\overline{\text{CSERR}}$ is driven by the card synchronous to CCLK, but deasserted by a weak pullup; deassertion may take several CCLK periods. The PCI4510 device can report $\overline{\text{CSERR}}$ to the system by assertion of $\overline{\text{SERR}}$ on the PCI interface.
CSTOP	155	E17	A09	I/O	CardBus stop. $\overline{\text{CSTOP}}$ is driven by a CardBus target to request the initiator to stop the current CardBus transaction. $\overline{\text{CSTOP}}$ is used for target disconnects, and is commonly asserted by target devices that do not support burst data transfers.
CSTSCHG	185	A09	B02	I	CardBus status change. CSTSCHG alerts the system to a change in the card status, and is used as a wake-up mechanism.
$\overline{\text{CTRDY}}$	159	E14	A08	I/O	CardBus target ready. $\overline{\text{CTRDY}}$ indicates the ability of the CardBus target to complete the current data phase of the transaction. A data phase is completed on a rising edge of CCLK, when both $\overline{\text{CIRDY}}$ and $\overline{\text{CTRDY}}$ are asserted; until this time, wait states are inserted.
CVS1 CVS2	181 167	B10 F12	A03 E08	I/O	CardBus voltage sense 1 and CardBus voltage sense 2. CVS1 and CVS2 are used in conjunction with $\overline{\text{CCD1}}$ and $\overline{\text{CCD2}}$ to identify card insertion and interrogate cards to determine the operating voltage and card type.

**Table 2–17. IEEE 1394 Physical Layer Terminals**

TERMINAL				I/O	DESCRIPTION
NAME	NUMBER				
	PDV	GHK	RGVF		
CNA	111	P17	P15	I/O	Cable not active. This terminal is asserted high when there are no ports receiving incoming bias voltage. If it is not used, then this terminal must be strapped either to GND through a resistor.
CPS	80	P10	M11	I	Cable power status input. This terminal is normally connected to cable power through a 400-k $\Omega$ resistor. This circuit drives an internal comparator that is used to detect the presence of cable power. If CPS is not used to detect cable power, then this terminal must be pulled to AV <sub>DD</sub> .
FILTER0 FILTER1	105 106	T19 R17	T18 T19	I/O	PLL filter terminals. These terminals are connected to an external capacitance to form a lag-lead filter required for stable operation of the internal frequency multiplier PLL running off of the crystal oscillator. A 0.1- $\mu$ F $\pm$ 10% capacitor is the only external component required to complete this filter.
PC0 PC1 PC2	77 76 75	V10 W10 P09	R12 U13 V13	I	Power class programming inputs. On hardware reset, these inputs set the default value of the power class indicated during self-ID. Programming is done by tying these terminals high or low.
R0 R1	91 92	W13 V13	U18 U19	–	Current-setting resistor terminals. These terminals are connected to an external resistance to set the internal operating currents and cable driver output currents. A resistance of 6.34 k $\Omega$ $\pm$ 1% is required to meet the IEEE Std 1394-1995 output voltage limits.
TPA0P TPA0N	87 86	V12 W12	V15 W15	I/O	Twisted-pair cable A differential signal terminals. Board trace lengths from each pair of positive and negative differential signal pins must be matched and as short as possible to the external load resistors and to the cable connector.
TPA1P TPA1N	101 99	V15 W15	V18 W18	I/O	
TPBIAS0 TPBIAS1	88 103	U12 U15	U15 U17	I/O	Twisted-pair bias output. This provides the 1.86-V nominal bias voltage needed for proper operation of the twisted-pair cable drivers and receivers and for signaling to the remote nodes that there is an active cable connection. Each of these pins must be decoupled with a 1.0- $\mu$ F capacitor to ground.
TPB0P TPB0N	82 81	V11 W11	V14 W14	I/O	Twisted-pair cable B differential signal terminals. Board trace lengths from each pair of positive and negative differential signal pins must be matched and as short as possible to the external load resistors and to the cable connector.
TPB1P TPB1N	96 95	V14 W14	V16 W16	I/O	
XI XO	109 110	R18 R19	R18 R19	–	Crystal oscillator inputs. These pins connect to a 24.576-MHz parallel resonant fundamental mode crystal. The optimum values for the external shunt capacitors are dependent on the specifications of the crystal used (see Section 3.11.2, <i>Crystal Selection</i> ). Terminal 5 has an internal 10-k $\Omega$ (nominal value) pulldown resistor. An external clock input can be connected to the XI terminal. When using an external clock input, the XO terminal must be left unconnected. Refer to Section 11.7 for the operating characteristics of the XI terminal.

**Table 2–18. Power Supply Terminals**

TERMINAL				I/O	DESCRIPTION
NAME	NUMBER				
	PDV	GHK	RGVF		
ANALOGGND	83 90 97	U11 R12 R13	N12 U14 U16	–	Analog circuit ground terminals.
ANALOGV <sub>CC</sub>	85 93 98	R11 U13 U14	R13 R14 V17	–	Analog circuit power terminals. A parallel combination of high frequency decoupling capacitors near each terminal is suggested, such as 0.1 μF and 0.001 μF. Lower frequency 10-μF filtering capacitors are also recommended. These supply terminals are separated from PLLV <sub>CC</sub> and PLLGND internal to the device to provide noise isolation. They must be tied at a low-impedance point on the circuit board.
PLLGND	108	N14	P14	–	PLL circuit ground terminals. This terminal must be tied to the low-impedance circuit board ground plane.
PLLV <sub>CC</sub>	107	P15	V19	–	PLL circuit power terminals. A parallel combination of high frequency decoupling capacitors near the terminal is suggested, such as 0.1 μF and 0.001 μF. Lower frequency 10-μF filtering capacitors are also recommended. This supply terminal is separated from AVDX internal to the device to provide noise isolation. It must be tied at a low-impedance point on the circuit board.

**Table 2–19. Smart Card and Memory Card Terminals**

TERMINAL				I/O	DESCRIPTION
NAME	NUMBER				
	PDV	GHK	RGVF		
MC_RSVD	113, 115, 116, 117, 118, 119, 120, 121, 122	N15, M14, N17, N18, N19, M15, M17, M18, M19	H07, G05, G03, H03, G02, J06, H05, F03, G01	–	Memory card terminals. Reserved for future use. These terminals must be left unconnected.
SC_RSVD	196, 197, 198, 199, 200, 201, 202	A06, B06, B07, C06, C07, E07, F07	J01, J02, J03, J05, J07, K01, K02	–	Smart card terminals. Reserved for future use. These terminals must be left unconnected.



### 3 Feature/Protocol Descriptions

The following sections give an overview of the PCI4510 device. Figure 3–1 shows the connections to the PCI4510 device. The PCI interface includes all address/data and control signals for PCI protocol. The interrupt interface includes terminals for parallel PCI, parallel ISA, and serialized PCI and ISA signaling.

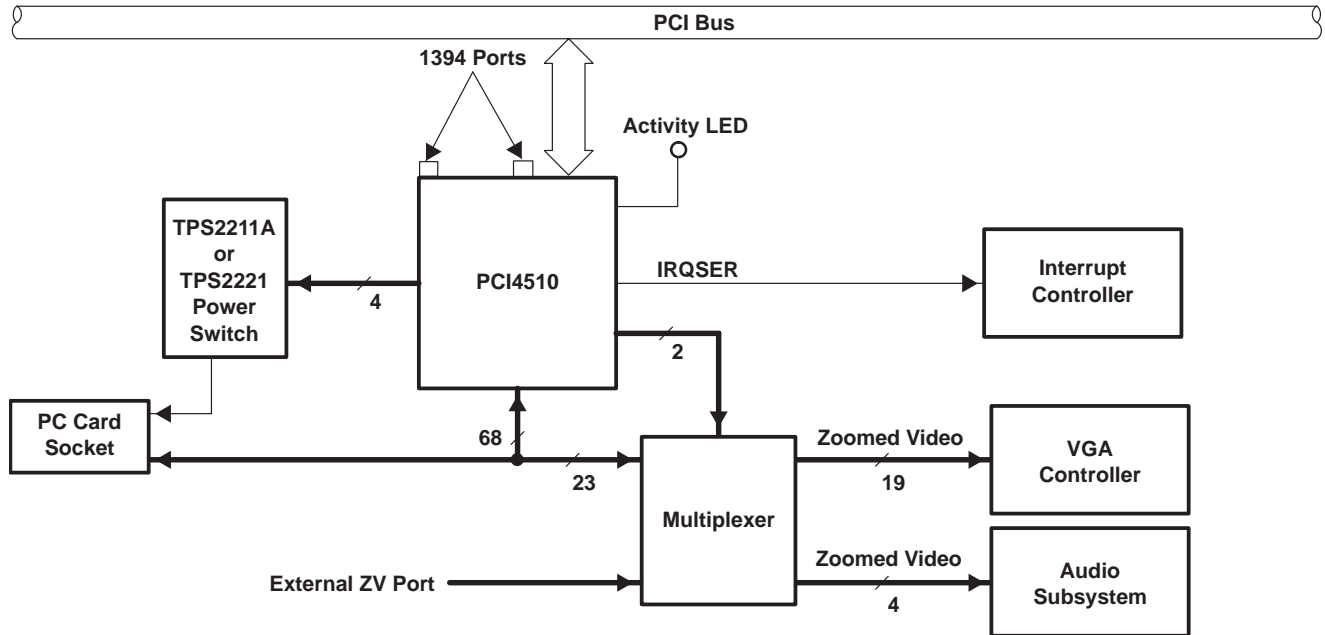

NOTE: The PC Card interface is 68 terminals for CardBus and 16-bit PC Cards. In ZV mode, 23 terminals are used for routing the ZV signals to the VGA controller and audio subsystem.

Figure 3–1. PCI4510 System Block Diagram

#### 3.1 Power Supply Sequencing

The PCI4510 device contains 3.3-V I/O buffers with 5-V tolerance requiring a core power supply and clamp voltages. The core power supply is always 1.8 V. The clamp voltages can be either 3.3 V or 5 V, depending on the interface. The following power-up and power-down sequences are recommended.

The power-up sequence is:

1. Assert  $\overline{\text{GRST}}$  to the device to disable the outputs during power up. Output drivers must be powered up in the high-impedance state to prevent high current levels through the clamp diodes to the 5-V supply.
2. Apply 3.3-V power to  $V_{CC}$ .
3. Apply the clamp voltage.

The power-down sequence is:

1. Assert  $\overline{\text{GRST}}$  to switch the outputs to the high-impedance state.
2. Remove the clamp voltage.
3. Remove the 3.3-V power from  $V_{CC}$ .

#### 3.2 I/O Characteristics

The PCI4510 device meets the ac specifications of the *PC Card Standard* (release 8.0) and *PCI Local Bus Specification*. Figure 3–2 shows a 3-state bidirectional buffer. Section 11.2, *Recommended Operating Conditions*, provides the electrical characteristics of the inputs and outputs.

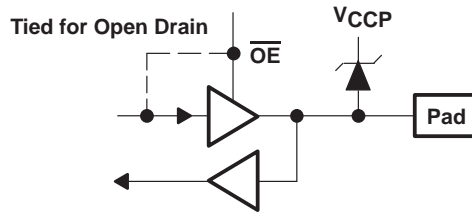

Figure 3–2. 3-State Bidirectional Buffer

### 3.3 Clamping Voltages

The clamping voltages are set to match whatever external environment the PCI4510 device is interfaced with: 3.3 V or 5 V. The I/O sites can be pulled through a clamping diode to a voltage rail that protects the core from external signals. The core power supply is always 3.3 V and is independent of the clamping voltages. For example, PCI signaling can be either 3.3 V or 5 V, and the PCI4510 device must reliably accommodate both voltage levels. This is accomplished by using a 3.3-V I/O buffer that is 5-V tolerant, with the applicable clamping voltage applied. If a system designer desires a 5-V PCI bus, then  $V_{CCP}$  can be connected to a 5-V power supply.

### 3.4 Peripheral Component Interconnect (PCI) Interface

The PCI4510 device is fully compliant with the *PCI Local Bus Specification*. The PCI4510 device provides all required signals for PCI master or slave operation, and may operate in either a 5-V or 3.3-V signaling environment by connecting the  $V_{CCP}$  terminals to the desired voltage level. In addition to the mandatory PCI signals, the PCI4510 device provides the optional interrupt signals  $\overline{INTA}$  and  $\overline{INTB}$ .

#### 3.4.1 1394 PCI Bus Master

As a bus master, the 1394 function of the PCI4510 device supports the memory commands specified in Table 3–1 below. The PCI master supports the memory read, memory read line, and memory read multiple commands. The read command usage for read transactions of greater than two data phases are determined by the selection in bits 9–8 (MR\_ENHANCE field) of the PCI miscellaneous configuration register (refer to Section 7.23 for details). For read transactions of one or two data phases, a memory read command is used.

Table 3–1. PCI Bus Master Command Support

PCI	COMMAND C/BE3–C/BE0	OHCI MASTER FUNCTION
Memory read	0110	DMA read from memory
Memory write	0111	DMA write to memory
Memory read multiple	1100	DMA read from memory
Memory read line	1110	DMA read from memory
Memory write and invalidate	1111	DMA write to memory

#### 3.4.2 PCI $\overline{GRST}$ Signal

During the power-up sequence,  $\overline{GRST}$  and  $\overline{PRST}$  must be asserted.  $\overline{GRST}$  can only be deasserted 100  $\mu$ s after PCLK is stable.  $\overline{PRST}$  can be deasserted at the same time as  $\overline{GRST}$  or any time thereafter.

### 3.4.3 PCI Bus Lock ( $\overline{\text{LOCK}}$ )

The bus-locking protocol defined in the *PCI Local Bus Specification* is not highly recommended, but is provided on the PCI4510 device as an additional compatibility feature. The PCI  $\overline{\text{LOCK}}$  signal can be routed to the MFUNC4 terminal by setting the appropriate values in bits 19–16 of the multifunction routing status register. See Section 4.34, *Multifunction Routing Status Register*, for details. Note that the use of  $\overline{\text{LOCK}}$  is only supported by PCI-to-CardBus bridges in the downstream direction (away from the processor).

PCI  $\overline{\text{LOCK}}$  indicates an atomic operation that may require multiple transactions to complete. When  $\overline{\text{LOCK}}$  is asserted, nonexclusive transactions can proceed to an address that is not currently locked. A grant to start a transaction on the PCI bus does not guarantee control of  $\overline{\text{LOCK}}$ ; control of  $\overline{\text{LOCK}}$  is obtained under its own protocol. It is possible for different initiators to use the PCI bus while a single master retains ownership of  $\overline{\text{LOCK}}$ . Note that the CardBus signal for this protocol is  $\overline{\text{CBLOCK}}$  to avoid confusion with the bus clock.

An agent may need to do an exclusive operation because a critical access to memory might be broken into several transactions, but the master wants exclusive rights to a region of memory. The granularity of the lock is defined by PCI to be 16 bytes, aligned. The  $\overline{\text{LOCK}}$  protocol defined by the *PCI Local Bus Specification* allows a resource lock without interfering with nonexclusive real-time data transfer, such as video.

The PCI bus arbiter may be designed to support only complete bus locks using the  $\overline{\text{LOCK}}$  protocol. In this scenario, the arbiter does not grant the bus to any other agent (other than the  $\overline{\text{LOCK}}$  master) while  $\overline{\text{LOCK}}$  is asserted. A complete bus lock may have a significant impact on the performance of the video. The arbiter that supports complete bus  $\overline{\text{LOCK}}$  must grant the bus to the cache to perform a writeback due to a snoop to a modified line when a locked operation is in progress.

The PCI4510 device supports all  $\overline{\text{LOCK}}$  protocols associated with PCI-to-PCI bridges, as also defined for PCI-to-CardBus bridges. This includes disabling write posting while a locked operation is in progress, which can solve a potential deadlock when using devices such as PCI-to-PCI bridges. The potential deadlock can occur if a CardBus target supports delayed transactions and blocks access to the target until it completes a delayed read. This target characteristic is prohibited by the *PCI Local Bus Specification*, and the issue is resolved by the PCI master using  $\overline{\text{LOCK}}$ .

### 3.4.4 Loading CardBus (Function 0) Subsystem Identification

The subsystem vendor ID register (PCI offset 40h, see Section 4.25) and subsystem ID register (PCI offset 42h, see Section 4.26) make up a doubleword of PCI configuration space for function 0. This doubleword register is used for system and option card (mobile dock) identification purposes and is required by some operating systems. Implementation of this unique identifier register is a *PC 99/PC 2001* requirement.

The PCI4510 device offers two mechanisms to load a read-only value into the subsystem registers. The first mechanism relies upon the system BIOS providing the subsystem ID value. The default access mode to the subsystem registers is read-only, but can be made read/write by setting bit 5 (SUBSYSRW) in the system control register (PCI offset 80h, see Section 4.28). Once this bit is set, the BIOS can write a subsystem identification value into the registers at PCI offset 40h. The BIOS must clear the SUBSYSRW bit such that the subsystem vendor ID register and subsystem ID register is limited to read-only access. This approach saves the added cost of implementing the serial electrically erasable programmable ROM (EEPROM).

In some conditions, such as in a docking environment, the subsystem vendor ID register and subsystem ID register must be loaded with a unique identifier via a serial EEPROM. The PCI4510 device loads the data from the serial EEPROM after a reset of the primary bus. Note that the  $\overline{\text{SUSPEND}}$  input gates the PCI reset from the entire PCI4510 core, including the serial-bus state machine (see Section 3.8.6, *Suspend Mode*, for details on using  $\overline{\text{SUSPEND}}$ ).

The PCI4510 device provides a two-line serial-bus host controller that can interface to a serial EEPROM. See Section 3.6, *Serial EEPROM Interface*, for details on the two-wire serial-bus controller and applications.

### 3.5 PC Card Applications

The PCI4510 device supports all the PC Card features and applications as described below.

- Card insertion/removal and recognition per the *PC Card Standard* (release 8.0)
- Zoomed video support
- Speaker and audio applications
- LED socket activity indicators
- PC Card controller programming model
- CardBus socket registers

#### 3.5.1 PC Card Insertion/Removal and Recognition

The *PC Card Standard* (release 8.0) addresses the card-detection and recognition process through an interrogation procedure that the socket must initiate on card insertion into a cold, nonpowered socket. Through this interrogation, card voltage requirements and interface (16-bit versus CardBus) are determined.

The scheme uses the card-detect and voltage-sense signals. The configuration of these four terminals identifies the card type and voltage requirements of the PC Card interface. The encoding scheme is defined in the *PC Card Standard* (release 8.0) and in Table 3–2.

**Table 3–2. PC Card Card-Detect and Voltage-Sense Connections**

$\overline{CD2}/\overline{CCD2}$	$\overline{CD1}/\overline{CCD1}$	$\overline{VS2}/\overline{CVS2}$	$\overline{VS1}/\overline{CVS1}$	KEY	INTERFACE	V <sub>CC</sub>	V <sub>PP</sub> /V <sub>CORE</sub>
Ground	Ground	Open	Open	5 V	16-bit PC Card	5 V	Per CIS (V <sub>PP</sub> )
Ground	Ground	Open	Ground	5 V	16-bit PC Card	5 V and 3.3 V	Per CIS (V <sub>PP</sub> )
Ground	Ground	Ground	Ground	5 V	16-bit PC Card	5 V, 3.3 V, and X.X V	Per CIS (V <sub>PP</sub> )
Ground	Ground	Open	Ground	LV	16-bit PC Card	3.3 V	Per CIS (V <sub>PP</sub> )
Ground	Connect to CVS1	Open	Connect to $\overline{CCD1}$	LV	CardBus PC Card	3.3 V	Per CIS (V <sub>PP</sub> )
Ground	Ground	Ground	Ground	LV	16-bit PC Card	3.3 V and X.X V	Per CIS (V <sub>PP</sub> )
Connect to CVS2	Ground	Connect to $\overline{CCD2}$	Ground	LV	CardBus PC Card	3.3 V and X.X V	Per CIS (V <sub>PP</sub> )
Connect to CVS1	Ground	Ground	Connect to $\overline{CCD2}$	LV	CardBus PC Card	3.3 V, X.X V, and Y.Y V	Per CIS (V <sub>PP</sub> )
Ground	Ground	Ground	Open	LV	16-bit PC Card	X.X V	Per CIS (V <sub>PP</sub> )
Connect to CVS2	Ground	Connect to $\overline{CCD2}$	Open	LV	CardBus PC Card	3.3 V	1.8 V(V <sub>CORE</sub> ) <sup>†</sup>
Ground	Connect to CVS2	Connect to $\overline{CCD1}$	Open	LV	CardBus PC Card	X.X V and Y.Y V	Per CIS (V <sub>PP</sub> )
Connect to CVS1	Ground	Open	Connect to $\overline{CCD2}$	LV	CardBus PC Card	Y.Y V	Per CIS (V <sub>PP</sub> )
Ground	Connect to CVS1	Ground	Connect to $\overline{CCD1}$	Reserved			
Ground	Connect to CVS2	Connect to $\overline{CCD1}$	Ground	Reserved			

<sup>†</sup> This hardware voltage selection setting cannot be overridden by CIS configuration settings.

#### 3.5.2 Zoomed Video Support

The PCI4510 allows for the implementation of zoomed video (ZV) for PC Cards. Zoomed video is supported by setting bit 6 (ZVENABLE) in the card control register (PCI offset 91h, see Section 4.36) on a per-socket function basis. Setting this bit puts 16-bit PC Card address lines A25–A4 of the PC Card interface in the high-impedance state. These lines can then transfer video and audio data directly to the appropriate controller. Card address lines A3–A0 can still access PC Card CIS registers for PC Card configuration. Figure 3–3 illustrates a PCI4510 ZV implementation.



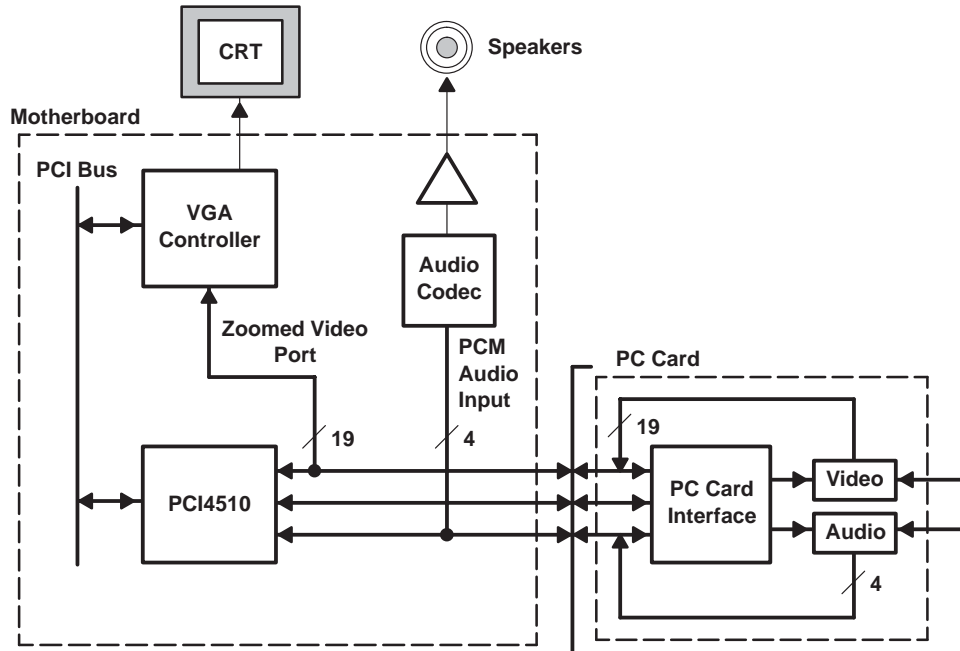

**Figure 3-3. Zoomed Video Implementation Using the PCI4510 Device**

Not shown in Figure 3-3 is the multiplexing scheme used to route the socket ZV source to the graphics controller. The PCI4510 device provides  $ZVSTAT$  and  $\overline{ZVSEL0}$  signals on the multifunction terminals to switch external bus drivers. Figure 3-4 shows an implementation for switching between two ZV streams using external logic.

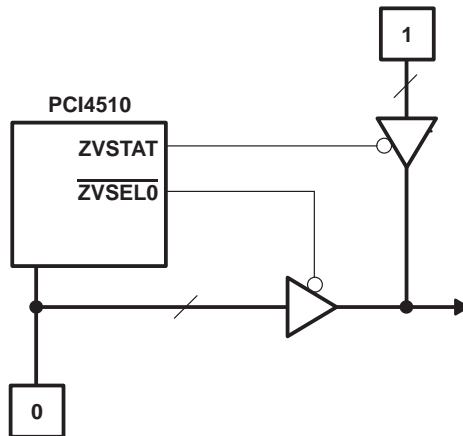

**Figure 3-4. Zoomed Video Switching Application**

Figure 3-4 illustrates an implementation using standard three-state bus drivers with active-low output enables.  $\overline{ZVSEL0}$  is an active-low output indicating that the CardBus socket ZV mode is enabled.

Also shown in Figure 3-4 is a second ZV input that can be provided from a source such as a high-speed serial bus like IEEE 1394. The  $ZVSTAT$  signal provides a mechanism to switch the third ZV source.  $ZVSTAT$  is an active-high output indicating that the PCI4510 socket is enabled for ZV mode. The implementation shown in Figure 3-4 can be used if PC Card ZV is prioritized over other sources.

### 3.5.3 Standardized Zoomed-Video Register Model

The standardized zoomed-video register model is defined for the purpose of standardizing the ZV port control for PC Card controllers across the industry. The following list summarizes the standardized zoomed-video register model changes to the existing PC Card register set.

- Socket present state register (CardBus socket address + 08h, see Section 6.3)  
Bit 27 (ZVSUPPORT) has been added. The platform BIOS can set this bit via the socket force event register (CardBus socket address + 0Ch, see Section 6.4) to define whether zoomed video is supported on that socket by the platform.
- Socket force event register (CardBus socket address + 0Ch, see Section 6.4)  
Bit 27 (FZVSUPPORT) has been added. The platform BIOS can use this bit to set bit 27 (ZVSUPPORT) in the socket present state register (CardBus socket address + 08h, see Section 6.3) to define whether zoomed video is supported on that socket by the platform.
- Socket control register (CardBus socket address +10h, see Section 6.5)  
Bit 11 (ZV\_ACTIVITY) has been added. This bit is set when zoomed video is enabled for either of the PC Card sockets.  
  
Bit 10 (STANDARDZVREG) has been added. This bit defines whether the PC Card controller supports the standardized zoomed-video register model.  
  
Bit 9 (ZVEN) is provided for software to enable or disable zoomed video, per socket.

If the ZV\_EN bit (bit 0) in the diagnostic register (PCI offset 93h, see Section 4.38) is 1, then the standardized zoomed video register model is disabled. For backward compatibility, even if the ZV\_EN bit is 0 (enabled), the PCI4510 device allows software to access zoomed video through the legacy address in the card control register (PCI offset 91h, see Section 4.36), or through the new register model in the socket control register (CardBus socket address + 10h, see Section 6.5).

### 3.5.4 Internal Ring Oscillator

The internal ring oscillator provides an internal clock source for the PCI4510 device so that neither the PCI clock nor an external clock is required in order for the PCI4510 device to power down a socket or interrogate a PC Card. This internal oscillator, operating nominally at 16 kHz, is always enabled.

### 3.5.5 Integrated Pullup Resistors for PC Card Interface

The *PC Card Standard* (release 8.0) requires pullup resistors on various terminals to support both CardBus and 16-bit card configurations. Unlike the PCI12XX, PCI1450, and PCI4450 devices which required external pullup resistors, the PCI4510 device has integrated all of these pullup resistors. The I/O buffer on the BVD1(STSCHG/RI)//CSTSCHG terminal has the capability to switch either pullup or pulldown resistor. The pullup resistor is turned on when a 16-bit PC Card is inserted, and the pulldown resistor is turned on when a CardBus PC Card is inserted. This prevents unexpected CSTSCHG signal assertion. The integrated pullup resistors are listed in Table 3–3.

**Table 3–3. Integrated Pullup Resistors**

SIGNAL NAME	TERMINAL NUMBER		
	PDV	GHK	RGVF
A14/CPERR	154	F15	F10
A15/CIRDY	160	F13	B08
A19/CBLOCK	153	E18	E10
A20/CSTOP	155	E17	A09
A21/CDEVSEL	157	A16	C09
A22/CTRDY	159	E14	A08
BVD1(STSCHG/RI)/CSTSCHG	185	A09	B02
BVD2(SPKR)/CAUDIO	184	F10	A02
CD1/CCD1	125	L17	C15
CD2/CCD2	187	C09	E05
INPACK/CREQ	173	B12	E07
READY/CINT	182	C10	C04
RESET/CRST	169	B13	A06
VS1/CVS1	181	B10	A03
VS2/CVS2	167	F12	E08
WAIT/CSERR	183	E10	B03
WP(IOIS16)/CCLKRUN	186	B09	C03

### 3.5.6 SPKROUT and CAUDPWM Usage

SPKROUT carries the digital audio signal from the PC Card to the system. When a 16-bit PC Card is configured for I/O mode, the BVD2 terminal becomes SPKR. This terminal is also used in CardBus binary audio applications, and is referred to as CAUDIO. SPKR passes a TTL-level digital audio signal to the PCI4510 device. The CardBus CAUDIO signal also can pass a single-amplitude binary waveform. The binary audio signals from the PC Card socket are XORed in the PCI4510 device to produce SPKROUT. This output is enabled by bit 1 (SPKROUTEN) in the card control register (PCI offset 91h, see Section 4.36).

Older controllers support CAUDIO in binary or PWM mode but use the same terminal (SPKROUT). Some audio chips may not support both modes on one terminal and may have a separate terminal for binary and PWM. The PCI4510 implementation includes a signal for PWM, CAUDPWM, which can be routed to an MFUNC terminal. Bit 2 (AUD2MUX), located in the card control register, is programmed on a per-socket function basis to route a CardBus CAUDIO PWM terminal to CAUDPWM. If both CardBus functions enable CAUDIO PWM routing to CAUDPWM, then CardBus socket audio takes precedence. See Section 4.34, *Multifunction Routing Status Register*, for details on configuring the MFUNC terminals.

Figure 3–5 provides an illustration of a sample application using SPKROUT and CAUDPWM.

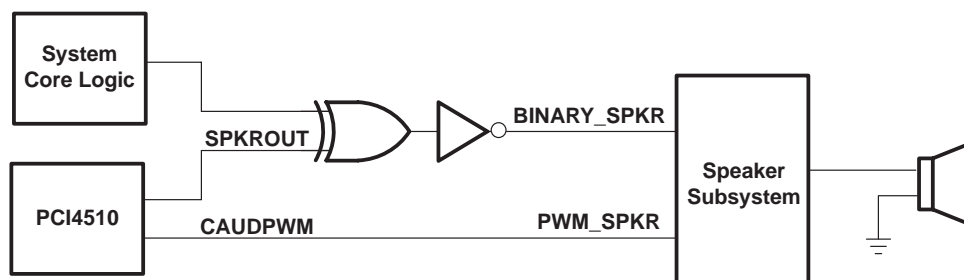

**Figure 3–5. Sample Application of SPKROUT and CAUDPWM**

### 3.5.7 LED Socket Activity Indicators

The socket activity LEDs are provided to indicate when a PC Card is being accessed. The LED\_SKT signal can be routed to the multifunction terminals. When configured for LED output, this terminal outputs an active high signal to indicate socket activity. The LED\_SKT output indicates socket activity to the CardBus socket. See Section 4.34, *Multifunction Routing Status Register*, for details on configuring the multifunction terminals.

The active-high LED signal is driven for 64 ms. When the LED is not being driven high, it is driven to a low state. Either of the two circuits shown in Figure 3–6 can be implemented to provide LED signaling, and the board designer must implement the circuit that best fits the application.

The LED activity signals are valid when a card is inserted, powered, and not in reset. For PC Card-16, the LED activity signals are pulsed when  $\overline{\text{READY}}(\overline{\text{IREQ}})$  is low. For CardBus cards, the LED activity signals are pulsed if  $\overline{\text{CFRAME}}$ ,  $\overline{\text{IRDY}}$ , or  $\overline{\text{CREQ}}$  are active.

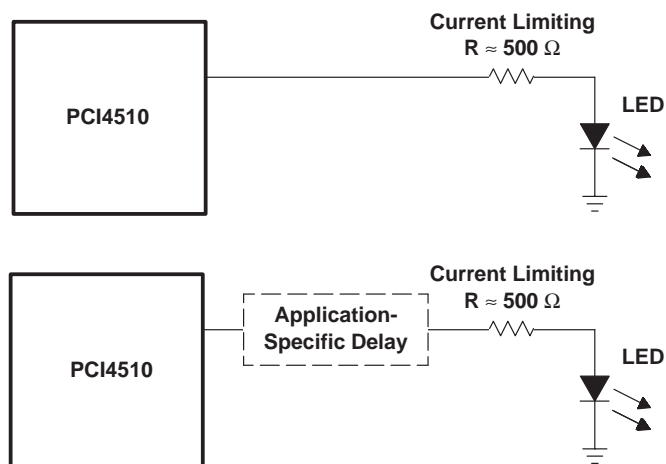

Figure 3–6. Two Sample LED Circuits

As indicated, the LED signals are driven for a period of 64 ms by a counter circuit. To avoid the possibility of the LEDs appearing to be stuck when the PCI clock is stopped, the LED signaling is cut off when the  $\overline{\text{SUSPEND}}$  signal is asserted, when the PCI clock is to be stopped during the clock run protocol, or when in the D2 or D1 power state.

If any additional socket activity occurs during this counter cycle, then the counter is reset and the LED signal remains driven. If socket activity is frequent (at least once every 64 ms), then the LED signals remain driven.

### 3.5.8 CardBus Socket Registers

The PCI4510 device contains all registers for compatibility with the *PC Card Standard*. These registers exist as the CardBus socket registers and are listed in Table 3–4.

Table 3–4. CardBus Socket Registers

REGISTER NAME	OFFSET
Socket event	00h
Socket mask	04h
Socket present state	08h
Socket force event	0Ch
Socket control	10h
Reserved	14h–1Ch
Socket power management	20h

## 3.6 Serial EEPROM Interface

The PCI4510 device has a dedicated serial bus interface that can be used with an EEPROM to load certain registers in the PCI4510 device. The EEPROM is detected by a pullup resistor on the SCL terminal. An EEPROM interface

exists in function 1 1394 OHCI and function 0 CardBus. The PCI4510 device includes a busy indication between the interfaces to allow all of the functions to load. Function 0 is loaded first, followed by function 1.

### 3.6.1 Serial-Bus Interface Implementation

The PCI4510 device drives SCL at nearly 100 kHz during data transfers, which is the maximum specified frequency for standard mode I<sup>2</sup>C. The serial EEPROM must be located at address A0h.

Some serial device applications may include PC Card power switches, ZV source switches, card ejectors, or other devices that may enhance the user's PC Card experience. The serial EEPROM device and PC Card power switches are discussed in the sections that follow.

### 3.6.2 Serial-Bus Interface Protocol

The SCL and SDA signals are bidirectional, open-drain signals and require pullup resistors. The PCI4510 device, which supports up to 100-Kb/s data-transfer rate, is compatible with standard mode I<sup>2</sup>C using 7-bit addressing.

All data transfers are initiated by the serial bus master. The beginning of a data transfer is indicated by a start condition, which is signaled when the SDA line transitions to the low state while SCL is in the high state, as illustrated in Figure 3–7. The end of a requested data transfer is indicated by a stop condition, which is signaled by a low-to-high transition of SDA while SCL is in the high state, as shown in Figure 3–7. Data on SDA must remain stable during the high state of the SCL signal, as changes on the SDA signal during the high state of SCL are interpreted as control signals, that is, a start or a stop condition.

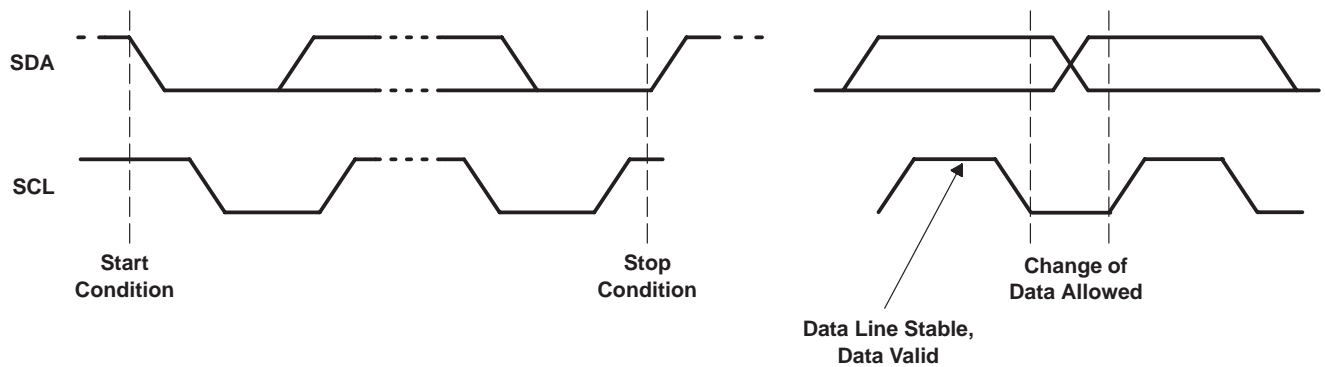

**Figure 3–7. Serial-Bus Start/Stop Conditions and Bit Transfers**

Data is transferred serially in 8-bit bytes. The number of bytes that may be transmitted during a data transfer is unlimited; however, each byte must be completed with an acknowledge bit. An acknowledge (ACK) is indicated by the receiver pulling the SDA signal low, so that it remains low during the high state of the SCL signal. Figure 3–8 illustrates the acknowledge protocol.

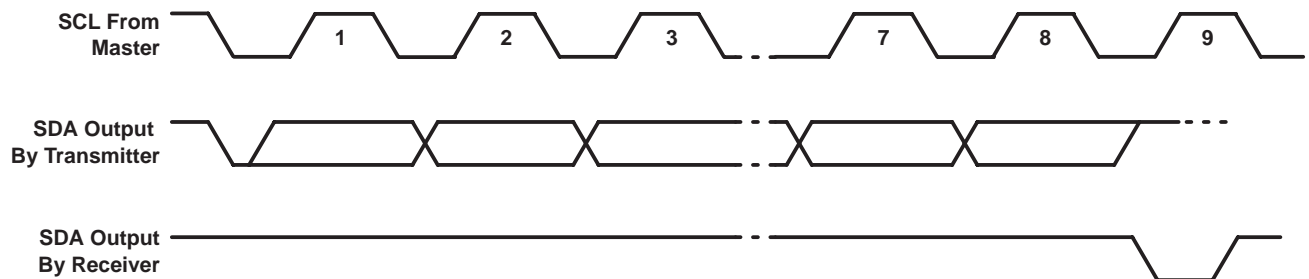
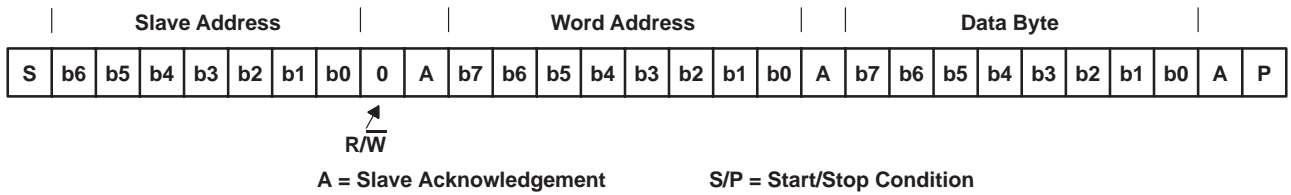

**Figure 3–8. Serial-Bus Protocol Acknowledge**

The PCI4510 device is a serial bus master; all other devices connected to the serial bus external to the PCI4510 device are slave devices. As the bus master, the PCI4510 device drives the SCL clock at nearly 100 kHz during bus cycles and places SCL in a high-impedance state (zero frequency) during idle states.

Typically, the PCI4510 device masters byte reads and byte writes under software control. Doubleword reads are performed by the serial EEPROM initialization circuitry upon a PCI reset and may not be generated under software control. See Section 3.6.3, *Serial-Bus EEPROM Application*, for details on how the PCI4510 device automatically loads the subsystem identification and other register defaults through a serial-bus EEPROM.

Figure 3–9 illustrates a byte write. The PCI4510 device issues a start condition and sends the 7-bit slave device address and the command bit zero. A 0 in the  $R/\overline{W}$  command bit indicates that the data transfer is a write. The slave device acknowledges if it recognizes the address. If no acknowledgment is received by the PCI4510 device, then an appropriate status bit is set in the serial-bus control and status register (PCI offset B3h, see Section 4.47). The word address byte is then sent by the PCI4510 device, and another slave acknowledgment is expected. Then the PCI4510 device delivers the data byte MSB first and expects a final acknowledgment before issuing the stop condition.



**Figure 3–9. Serial-Bus Protocol – Byte Write**

Figure 3–10 illustrates a byte read. The read protocol is very similar to the write protocol, except the  $R/\overline{W}$  command bit must be set to 1 to indicate a read-data transfer. In addition, the PCI4510 master must acknowledge reception of the read bytes from the slave transmitter. The slave transmitter drives the SDA signal during read data transfers. The SCL signal remains driven by the PCI4510 master.

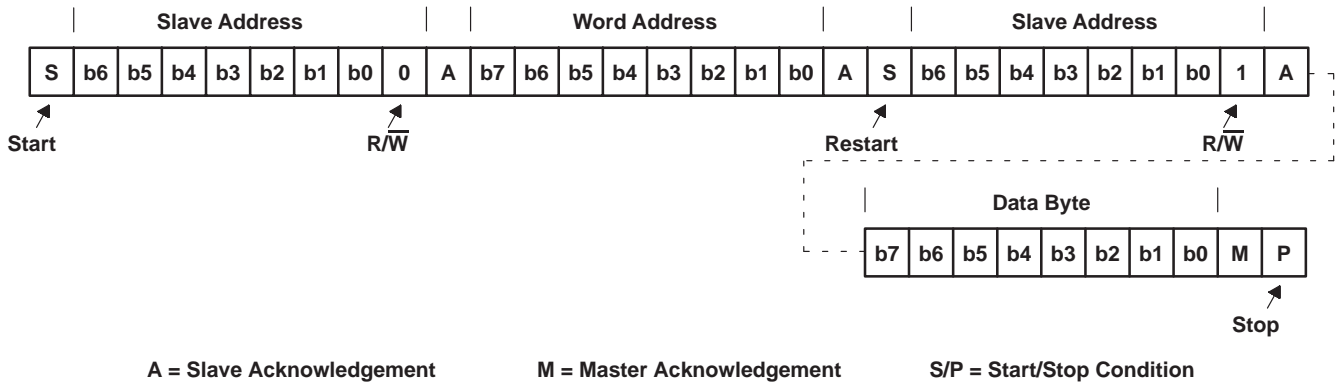

**Figure 3–10. Serial-Bus Protocol – Byte Read**

Figure 3–11 illustrates EEPROM interface doubleword data collection protocol.

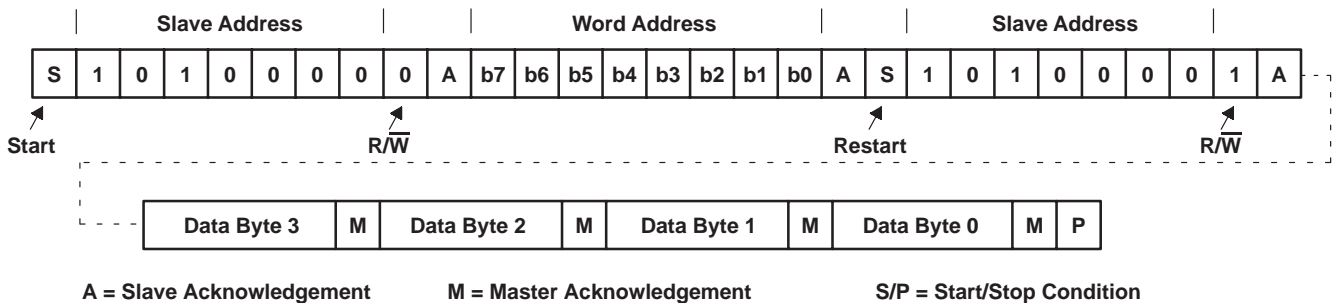

**Figure 3–11. EEPROM Interface Doubleword Data Collection**

### 3.6.3 Serial-Bus EEPROM Application

When the PCI bus is reset and the serial-bus interface is detected, the PCI4510 device attempts to read the subsystem identification and other register defaults from a serial EEPROM. See Table 3–5 for the EEPROM loading map.

This format must be followed for the PCI4510 device to load initializations from a serial EEPROM. All bit fields must be considered when programming the EEPROM.

The serial EEPROM is addressed at slave address 1010 000b by the PCI4510 device. All hardware address bits for the EEPROM must be tied to the appropriate level to achieve this address. The serial EEPROM chip in the sample application (see Figure 3–11) assumes the 1010b high-address nibble. The lower three address bits are terminal inputs to the chip, and the sample application shows these terminal inputs tied to GND.

**Table 3–5. EEPROM Loading Map**

SERIAL ROM OFFSET	BYTE DESCRIPTION					
	<b>FUNCTION 1 – 1394 OHCI</b>					
00h	PCI 3Fh, MaxLat, bits 7–4			PCI 3Eh, MinGnt, bits 3–0		
01h	PCI 2Ch, subsystem vendor ID, byte 0					
02h	PCI 2Dh, subsystem vendor ID, byte 1					
03h	PCI 2Eh, subsystem ID, byte 0					
04h	PCI 2Fh, subsystem ID, byte 1					
05h	PCI F4h, Link_Enh, byte 0, bits 7, 2, 1 OHCI 50h, host controller control, bit 23					
	[7] Link_Enh. enab_unfair	[6] HCControl.Program Phy Enable	[5:3] RSVD	[2] Link_Enh, bit 2	[1] Link_Enh. enab_accel	[0] RSVD
06h	Mini-ROM addr, bits 6:5 are used to indicate that the MINI ROM is present 00b = No MINI ROM 01b = MINI ROM starts at offset 20h 10b = MINI ROM starts at offset 40h 11b = MINI ROM starts at offset 60h					
07h	OHCI 24h, GUIDHi, byte 0					
08h	OHCI 25h, GUIDHi, byte 1					
09h	OHCI 26h, GUIDHi, byte 2					
0Ah	OHCI 27h, GUIDHi, byte 3					
0Bh	OHCI 28h, GUIDLo, byte 0					
0Ch	OHCI 29h, GUIDLo, byte 1					
0Dh	OHCI 2Ah, GUIDLo, byte 2					
0Eh	OHCI 2Bh, GUIDLo, byte 3					
0Fh	Checksum (Reserved—no bit loaded)					
10h	PCI F5h, Link_Enh, byte 1, bits 7, 6, 5, 4					
11h	PCI F0h, PCI miscellaneous, byte 0, bits 5, 4, 2, 1, 0					
12h	PCI F1h, PCI miscellaneous, byte 1, bits 7, 2, 1, 0					
13h	Reserved					
14h	Reserved (CardBus CIS pointer)					
15h	Reserved					
16h	PCI ECh, PCI PHY control, bits 7, 3, 2, 1, 0					
17h–1Fh	Reserved					

**Table 3–5. EEPROM Loading Map (Continued)**

SERIAL ROM OFFSET	BYTE DESCRIPTION						
	<b>FUNCTION 0 – CARDBUS</b>						
21h	PCI 04h, command register, bits 8, 6–5, 2–0						
	[7] Command register bit 8	[6] Command register bit 6	[5] Command register bit 5	[4:3] RSVD	[2] Command register bit 2	[1] Command register bit 1	[0] Command register bit 0
22h	PCI 40h, subsystem vendor ID, byte 0						
23h	PCI 41h, subsystem vendor ID, byte 1						
24h	PCI 42h, subsystem ID, byte 0						
25h	PCI 43h, subsystem ID, byte 1						
26h	PCI 44h, PC Card 16-bit I/F legacy mode base address register, byte 0, bits 7–1						
27h	PCI 45h, PC Card 16-bit I/F legacy mode base address register, byte 1						
28h	PCI 46h, PC Card 16-bit I/F legacy mode base address register, byte 2						
29h	PCI 47h, PC Card 16-bit I/F legacy mode base address register, byte 3						
2Ah	PCI 80h, system control, byte 0						
2Bh	PCI 81h, system control, byte 1						
2Ch	Reserved—Load all 0s						
2Dh	PCI 83h, system control, byte 3						
2Eh	PCI 8Ch, multifunction routing, byte 0						
2Fh	PCI 8Dh, multifunction routing, byte 1						
30h	PCI 8Eh, multifunction routing, byte 2						
31h	PCI 8Fh, multifunction routing, byte 3						
32h	PCI 90h retry status, bits 7, 6						
33h	PCI 91h, card control, bit 7						
34h	PCI 92h, device control, bits 6, 5, 3–0						
35h	PCI 93h, diagnostic, bits 7, 4–0						
36h	PCI A2h, power management capabilities, bit 15 (bit 7 of EEPROM offset 36h corresponds to bit 15)						
37h	Reserved—Load all 0s						
38h	Reserved—Load all 0s						
39h	ExCA 00h, ExCA identification and revision, bits 7–0						
3Ah	PCI 86h, general control, byte 0, bits 3, 1, 0						
3Bh	PCI 87h, general control, byte 1, bit 2						
3Ch	PCI 89h, $\overline{\text{GPE}}$ Enable, bits 7, 6, 4–0						
3Dh	PCI 8Bh, general-purpose output, bits 4–0						
3Eh–49h	Reserved—Load all 0s						

### 3.6.4 Accessing Serial-Bus Devices Through Software

The PCI4510 device provides a programming mechanism to control serial bus devices through software. The programming is accomplished through a doubleword of PCI configuration space at offset B0h. Table 3–6 lists the registers used to program a serial-bus device through software.



**Table 3–6. PCI4510 Registers Used to Program Serial-Bus Devices**

PCI OFFSET	REGISTER NAME	DESCRIPTION
B0h	Serial-bus data	Contains the data byte to send on write commands or the received data byte on read commands.
B1h	Serial-bus index	The content of this register is sent as the word address on byte writes or reads. This register is not used in the quick command protocol.
B2h	Serial-bus slave address	Write transactions to this register initiate a serial-bus transaction. The slave device address and the $\overline{R/\overline{W}}$ command selector are programmed through this register.
B3h	Serial-bus control and status	Read data valid, general busy, and general error status are communicated through this register. In addition, the protocol-select bit is programmed through this register.

### 3.7 Programmable CardBus Interrupt Subsystem

Interrupts provide a way for I/O devices to let the microprocessor know that they require servicing. The dynamic nature of PC Cards and the abundance of PC Card I/O applications require substantial interrupt support from the PCI4510 device. The PCI4510 device provides several interrupt signaling schemes to accommodate the needs of a variety of platforms. The different mechanisms for dealing with interrupts in this device are based on various specifications and industry standards. The ExCA register set provides interrupt control for some 16-bit PC Card functions, and the CardBus socket register set provides interrupt control for the CardBus PC Card functions. The PCI4510 device is, therefore, backward compatible with existing interrupt control register definitions, and new registers have been defined where required.

The PCI4510 device detects PC Card interrupts and events at the PC Card interface and notifies the host controller using one of several interrupt signaling protocols. To simplify the discussion of interrupts in the PCI4510 device, PC Card interrupts are classified either as card status change (CSC) or as functional interrupts.

The method by which any type of PCI4510 interrupt is communicated to the host interrupt controller varies from system to system. The PCI4510 device offers system designers the choice of using parallel PCI interrupt signaling, parallel ISA-type IRQ interrupt signaling, or the IRQSER serialized ISA and/or PCI interrupt protocol. It is possible to use the parallel PCI interrupts in combination with either parallel IRQs or serialized IRQs. All interrupt signaling is provided through the seven multifunction terminals, MFUNC0–MFUNC6.

#### 3.7.1 PC Card Functional and Card Status Change Interrupts

PC Card functional interrupts are defined as requests from a PC Card application for interrupt service and are indicated by asserting specially-defined signals on the PC Card interface. Functional interrupts are generated by 16-bit I/O PC Cards and by CardBus PC Cards.

Card status change (CSC)-type interrupts are defined as events at the PC Card interface that are detected by the PCI4510 device and may warrant notification of host card and socket services software for service. CSC events include both card insertion and removal from PC Card socket, as well as transitions of certain PC Card signals.

Table 3–7 summarizes the sources of PC Card interrupts and the type of card associated with them. CSC and functional interrupt sources are dependent on the type of card inserted in the PC Card socket. The three types of cards that can be inserted into any PC Card socket are:

- 16-bit memory card
- 16-bit I/O card
- CardBus cards

**Table 3–7. Interrupt Mask and Flag Registers**

CARD TYPE	EVENT	MASK	FLAG
16-bit memory	Battery conditions (BVD1, BVD2)	ExCA offset 05h/805h bits 1 and 0	ExCA offset 04h/804h bits 1 and 0
	Wait states (READY)	ExCA offset 05h/805h bit 2	ExCA offset 04h/804h bit 2
16-bit I/O	Change in card status ( $\overline{STSCHG}$ )	ExCA offset 05h/805h bit 0	ExCA offset 04h/804h bit 0
	Interrupt request ( $\overline{IREQ}$ )	Always enabled	PCI configuration offset 91h bit 0
All 16-bit PC Cards	Power cycle complete	ExCA offset 05h/805h bit 3	ExCA offset 04h/804h bit 3
CardBus	Change in card status ( $\overline{CSTSCHG}$ )	Socket mask bit 0	Socket event bit 0
	Interrupt request ( $\overline{CINT}$ )	Always enabled	PCI configuration offset 91h bit 0
	Power cycle complete	Socket mask bit 3	Socket event bit 3
	Card insertion or removal	Socket mask bits 2 and 1	Socket event bits 2 and 1

Functional interrupt events are valid only for 16-bit I/O and CardBus cards; that is, the functional interrupts are not valid for 16-bit memory cards. Furthermore, card insertion and removal-type CSC interrupts are independent of the card type.

**Table 3–8. PC Card Interrupt Events and Description**

CARD TYPE	EVENT	TYPE	SIGNAL	DESCRIPTION
16-bit memory	Battery conditions (BVD1, BVD2)	CSC	$\overline{BVD1}(\overline{STSCHG})//\overline{CSTSCHG}$	A transition on BVD1 indicates a change in the PC Card battery conditions.
			$\overline{BVD2}(\overline{SPKR})//\overline{CAUDIO}$	A transition on BVD2 indicates a change in the PC Card battery conditions.
	Wait states (READY)	CSC	$\overline{READY}(\overline{IREQ})//\overline{CINT}$	A transition on READY indicates a change in the ability of the memory PC Card to accept or provide data.
16-bit I/O	Change in card status ( $\overline{STSCHG}$ )	CSC	$\overline{BVD1}(\overline{STSCHG})//\overline{CSTSCHG}$	The assertion of $\overline{STSCHG}$ indicates a status change on the PC Card.
	Interrupt request ( $\overline{IREQ}$ )	Functional	$\overline{READY}(\overline{IREQ})//\overline{CINT}$	The assertion of $\overline{IREQ}$ indicates an interrupt request from the PC Card.
CardBus	Change in card status ( $\overline{CSTSCHG}$ )	CSC	$\overline{BVD1}(\overline{STSCHG})//\overline{CSTSCHG}$	The assertion of $\overline{CSTSCHG}$ indicates a status change on the PC Card.
	Interrupt request ( $\overline{CINT}$ )	Functional	$\overline{READY}(\overline{IREQ})//\overline{CINT}$	The assertion of $\overline{CINT}$ indicates an interrupt request from the PC Card.
All PC Cards	Card insertion or removal	CSC	$\overline{CD1}//\overline{CCD1}$ $\overline{CD2}//\overline{CCD2}$	A transition on either $\overline{CD1}//\overline{CCD1}$ or $\overline{CD2}//\overline{CCD2}$ indicates an insertion or removal of a 16-bit or CardBus PC Card.
	Power cycle complete	CSC	N/A	An interrupt is generated when a PC Card power-up cycle has completed.

The naming convention for PC Card signals describes the function for 16-bit memory, I/O cards, and CardBus. For example,  $\overline{READY}(\overline{IREQ})//\overline{CINT}$  includes  $\overline{READY}$  for 16-bit memory cards,  $\overline{IREQ}$  for 16-bit I/O cards, and  $\overline{CINT}$  for CardBus cards. The 16-bit memory card signal name is first, with the I/O card signal name second, enclosed in parentheses. The CardBus signal name follows after a double slash (/).

The *PC Card Standard* describes the power-up sequence that must be followed by the PCI4510 device when an insertion event occurs and the host requests that the socket  $V_{CC}$  and  $V_{PP}$  be powered. Upon completion of this power-up sequence, the PCI4510 interrupt scheme can be used to notify the host system (see Table 3–8), denoted by the power cycle complete event. This interrupt source is considered a PCI4510 internal event, because it depends on the completion of applying power to the socket rather than on a signal change at the PC Card interface.

### 3.7.2 Interrupt Masks and Flags

Host software may individually mask (or disable) most of the potential interrupt sources listed in Table 3–8 by setting the appropriate bits in the PCI4510 device. By individually masking the interrupt sources listed, software can control those events that cause a PCI4510 interrupt. Host software has some control over the system interrupt the PCI4510 device asserts by programming the appropriate routing registers. The PCI4510 device allows host software to route PC Card CSC and PC Card functional interrupts to separate system interrupts. Interrupt routing somewhat specific to the interrupt signaling method used is discussed in more detail in the following sections.

When an interrupt is signaled by the PCI4510 device, the interrupt service routine must determine which of the events listed in Table 3–7 caused the interrupt. Internal registers in the PCI4510 device provide flags that report the source of an interrupt. By reading these status bits, the interrupt service routine can determine the action to be taken.

Table 3–7 details the registers and bits associated with masking and reporting potential interrupts. All interrupts can be masked except the functional PC Card interrupts, and an interrupt status flag is available for all types of interrupts.

Notice that there is not a mask bit to stop the PCI4510 device from passing PC Card functional interrupts through to the appropriate interrupt scheme. These interrupts are not valid until the card is properly powered, and there must never be a card interrupt that does not require service after proper initialization.

Table 3–7 lists the various methods of clearing the interrupt flag bits. The flag bits in the ExCA registers (16-bit PC Card-related interrupt flags) can be cleared using two different methods. One method is an explicit write of 1 to the flag bit to clear and the other is by reading the flag bit register. The selection of flag bit clearing methods is made by bit 2 (IFCMODE) in the ExCA global control register (ExCA offset 1Eh/81Eh, see Section 5.20), and defaults to the flag-cleared-on-read method.

The CardBus-related interrupt flags can be cleared by an explicit write of 1 to the interrupt flag in the socket event register (see Section 6.1). Although some of the functionality is shared between the CardBus registers and the ExCA registers, software must not program the chip through both register sets when a CardBus card is functioning.

### 3.7.3 Using Parallel IRQ Interrupts

The seven multifunction terminals, MFUNC6–MFUNC0, implemented in the PCI4510 device can be routed to obtain a subset of the ISA IRQs. The IRQ choices provide ultimate flexibility in PC Card host interruptions. To use the parallel ISA-type IRQ interrupt signaling, software must program the device control register (PCI offset 92h, see Section 4.37), to select the parallel IRQ signaling scheme. See Section 4.34, *Multifunction Routing Status Register*, for details on configuring the multifunction terminals.

A system using parallel IRQs requires (at a minimum) one PCI terminal,  $\overline{\text{INTA}}$ , to signal CSC events. This requirement is dictated by certain card and socket-services software. The  $\overline{\text{INTA}}$  requirement calls for routing the MFUNC0 terminal for  $\overline{\text{INTA}}$  signaling. The INTRTIE bit is used, in this case, to route socket interrupt events to  $\overline{\text{INTA}}$ . This leaves (at a maximum) six different IRQs to support legacy 16-bit PC Card functions.

As an example, suppose the six IRQs used by legacy PC Card applications are IRQ3, IRQ4, IRQ5, IRQ10, IRQ11, and IRQ15. The multifunction routing status register must be programmed to a value of 0FBA 5432h. This value routes the MFUNC0 terminal to  $\overline{\text{INTA}}$  signaling and routes the remaining terminals as illustrated in Figure 3–12. Not shown is that  $\overline{\text{INTA}}$  must also be routed to the programmable interrupt controller (PIC), or to some circuitry that provides parallel PCI interrupts to the host.

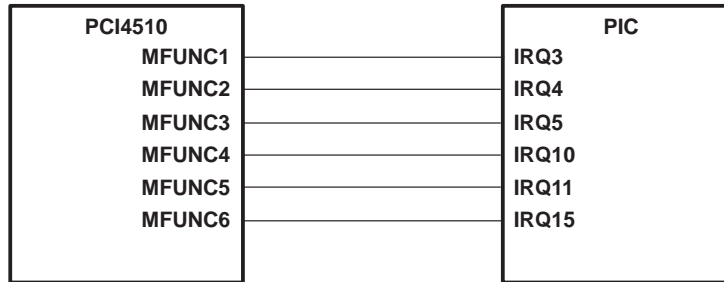

**Figure 3–12. IRQ Implementation**

Power-on software is responsible for programming the multifunction routing status register to reflect the IRQ configuration of a system implementing the PCI4510 device. The multifunction routing status register is shared between the two PCI4510 functions, and only one write to function 0 or 1 is necessary to configure the MFUNC6–MFUNC0 signals. Writing to function 0 only is recommended. See Section 4.34, *Multifunction Routing Status Register*, for details on configuring the multifunction terminals.

The parallel ISA-type IRQ signaling from the MFUNC6–MFUNC0 terminals is compatible with the input signal requirements of the 8259 PIC. The parallel IRQ option is provided for system designs that require legacy ISA IRQs. Design constraints may demand more MFUNC6–MFUNC0 IRQ terminals than the PCI4510 device makes available.

### 3.7.4 Using Parallel PCI Interrupts

Parallel PCI interrupts are available when exclusively in parallel PCI interrupt/parallel ISA IRQ signaling mode, and when only IRQs are serialized with the IRQSER protocol. Both  $\overline{INTA}$  and  $\overline{INTB}$  can be routed to MFUNC terminals (MFUNC0 and MFUNC1). However, interrupts of both socket functions can be routed to  $\overline{INTA}$  (MFUNC0) if bit 29 (INTRTIE) is set in the system control register (PCI offset 80h, see Section 4.28).

The INTRTIE bit affects the read-only value provided through accesses to the interrupt pin register (PCI offset 3Dh, see Section 4.23). When the INTRTIE bit is set, both functions return a value of 01h on reads from the interrupt pin register for both parallel and serial PCI interrupts. Table 3–9 summarizes the interrupt signaling modes.

**Table 3–9. Interrupt Pin Register Cross Reference**

INTRTIE BIT	INTPIN	
	FUNCTION 0	FUNCTION 1
0	01h	02h
1	01h	01h

### 3.7.5 Using Serialized IRQSER Interrupts

The serialized interrupt protocol implemented in the PCI4510 device uses a single terminal to communicate all interrupt status information to the host controller. The protocol defines a serial packet consisting of a start cycle, multiple interrupt indication cycles, and a stop cycle. All data in the packet is synchronous with the PCI clock. The packet data describes 16 parallel ISA IRQ signals and the optional 4 PCI interrupts  $\overline{INTA}$ ,  $\overline{INTB}$ ,  $\overline{INTC}$ , and  $\overline{INTD}$ . For details on the IRQSER protocol, refer to the document *Serialized IRQ Support for PCI Systems*.

### 3.7.6 SMI Support in the PCI4510 Device

The PCI4510 device provides a mechanism for interrupting the system when power changes have been made to the PC Card socket interfaces. The interrupt mechanism is designed to fit into a system maintenance interrupt (SMI) scheme. SMI interrupts are generated by the PCI4510 device, when enabled, after a write cycle to either the socket control register (CB offset 10h, see Section 6.5) of the CardBus register set, or the ExCA power control register (ExCA offset 02h/802h, see Section 5.3) causes a power cycle change sequence to be sent on the power switch interface.

The SMI control is programmed through three bits in the system control register (PCI offset 80h, see Section 4.28). These bits are SMIRROUTE (bit 26), SMISTATUS (bit 25), and SMIENB (bit 24). Table 3–10 describes the SMI control bits function.

**Table 3–10. SMI Control**

BIT NAME	FUNCTION
SMIRROUTE	This shared bit controls whether the SMI interrupts are sent as a CSC interrupt or as IRQ2.
SMISTAT	This socket dependent bit is set when an SMI interrupt is pending. This status flag is cleared by writing back a 1.
SMIENB	When set, SMI interrupt generation is enabled. This bit is shared by functions 0 and 1.

If CSC SMI interrupts are selected, then the SMI interrupt is sent as the CSC on a per-socket basis. The CSC interrupt can be either level or edge mode, depending upon the CSCMODE bit in the ExCA global control register (ExCA offset 1Eh/81Eh, see Section 5.20).

If IRQ2 is selected by SMIRROUTE, then the IRQSER signaling protocol supports SMI signaling in the IRQ2 IRQ/Data slot. In a parallel ISA IRQ system, the support for an active low IRQ2 is provided only if IRQ2 is routed to either MFUNC3 or MFUNC6 through the multifunction routing status register (PCI offset 8Ch, see Section 4.34).

### 3.8 Power Management Overview

In addition to the low-power CMOS technology process used for the PCI4510 device, various features are designed into the device to allow implementation of popular power-saving techniques. These features and techniques are as follows:

- Clock run protocol
- Cardbus PC Card power management
- 16-bit PC Card power management
- Suspend mode
- Ring indicate
- PCI power management
- Cardbus bridge power management
- ACPI support

#### 3.8.1 1394 Power Management (Function 1)

The PCI4510 device complies with *PCI Bus Power Management Interface Specification*. The device supports the D0 (uninitialized), D0 (active), D1, D2, and D3 power states as defined by the power management definition in the *1394 Open Host Controller Interface Specification*, Appendix A.4.  $\overline{\text{PME}}$  is supported to provide notification of wake events. Per Section A.4.2, the 1394 OHCI sets PMCSR.PME\_STS in the D0 state due to unmasked interrupt events. In previous OHCI implementations, unmasked interrupt events was interpreted as (IntEvent.n && IntMask.n && IntMask.masterIntEnable), where n represents a specific interrupt event. Based on feedback from Microsoft this implementation may cause problems with the existing Windows power management architecture as a  $\overline{\text{PME}}$  and an interrupt could be simultaneously signaled on a transition from the D1 to D0 state where interrupts were enabled to generate wake events. If bit 10 (ignore\_mstrIntEna\_for\_pme) in the PCI miscellaneous configuration register (OHCI offset F0h, see Section 7.23) is set, then the PCI4510 device implements the preferred behavior as (IntEvent.n && IntMask.n). Otherwise, the PCI4510 device implements the preferred behavior as (IntEvent.n && IntMask.n && IntMask.masterIntEnable). In addition, when the ignore\_mstrIntEna\_for\_pme bit is set, it causes bit 26 of the OHCI vendor ID register (OHCI offset 40h, see Section 8.15) to read 1, otherwise, bit 26 reads 0. An open drain buffer is used for  $\overline{\text{PME}}$ .

#### 3.8.2 Integrated Low-Dropout Voltage Regulator (LDO-VR)

The PCI4510 device requires 1.8-V core voltage. The core power can be supplied by the PCI4510 device itself using the internal LDO-VR. The core power can alternatively be supplied by an external power supply through the VR\_PORT terminal. Table 3–11 lists the requirements for both the internal core power supply and the external core power supply.

**Table 3–11. Requirements for Internal/External 1.8-V Core Power Supply**

SUPPLY	V <sub>CC</sub>	$\overline{VR\_EN}$	VR_PORT	NOTE
Internal	3.3 V	GND	1.8-V output	Internal 1.8-V LDO-VR is enabled. A 1.0- $\mu$ F bypass capacitor is required on the VR_PORT terminal for decoupling. This output is not for external use.
External	3.3 V	V <sub>CC</sub>	1.8-V input	Internal 1.8-V LDO-VR is disabled. An external 1.8-V power supply, of minimum 50-mA capacity, is required. A 0.1- $\mu$ F bypass capacitor on the VR_PORT terminal is required.

### 3.8.3 CardBus (Function 0) Clock Run Protocol

The PCI  $\overline{CLKRUN}$  feature is the primary method of power management on the PCI interface of the PCI4510 device.  $\overline{CLKRUN}$  signaling is provided through the MFUNC6 terminal. Since some chip sets do not implement  $\overline{CLKRUN}$ , this is not always available to the system designer, and alternate power-saving features are provided. For details on the  $\overline{CLKRUN}$  protocol see the *PCI Mobile Design Guide*.

The PCI4510 device does not permit the central resource to stop the PCI clock under any of the following conditions:

- Bit 1 (KEEPCLK) in the system control register (PCI offset 80h, see Section 4.28) is set.
- The 16-bit PC Card resource manager is busy.
- The PCI4510 CardBus master state machine is busy. A cycle may be in progress on CardBus.
- The PCI4510 master is busy. There may be posted data from CardBus to PCI in the PCI4510 device.
- Interrupts are pending.
- The CardBus CCLK for the socket has not been stopped by the PCI4510  $\overline{CCLKRUN}$  manager.

The PCI4510 device restarts the PCI clock using the  $\overline{CLKRUN}$  protocol under any of the following conditions:

- A 16-bit PC Card  $\overline{IREQ}$  or a CardBus  $\overline{CINT}$  has been asserted by either card.
- A CardBus CBWAKE (CSTSCHG) or 16-bit PC Card  $\overline{STSCHG/RI}$  event occurs in the socket.
- A CardBus attempts to start the CCLK using  $\overline{CCLKRUN}$ .
- A CardBus card arbitrates for the CardBus bus using  $\overline{CREQ}$ .

### 3.8.4 CardBus PC Card Power Management

The PCI4510 device implements its own card power-management engine that can turn off the CCLK to a socket when there is no activity to the CardBus PC Card. The PCI clock-run protocol is followed on the CardBus  $\overline{CCLKRUN}$  interface to control this clock management.

### 3.8.5 16-Bit PC Card Power Management

The COE bit (bit 7) of the ExCA power control register (ExCA offset 02h/802h, see Section 5.3) and PWRDWN bit (bit 0) of the ExCA global control register (ExCA offset 1Eh/81Eh, see Section 5.20) bits are provided for 16-bit PC Card power management. The COE bit places the card interface in a high-impedance state to save power. The power savings when using this feature are minimal. The COE bit resets the PC Card when used, and the PWRDWN bit does not. Furthermore, the PWRDWN bit is an automatic COE, that is, the PWRDWN performs the COE function when there is no card activity.

**NOTE:** The 16-bit PC Card must implement the proper pullup resistors for the COE and PWRDWN modes.

### 3.8.6 Suspend Mode

The  $\overline{SUSPEND}$  signal, provided for backward compatibility, gates the  $\overline{PRST}$  (PCI reset) signal and the  $\overline{GRST}$  (global reset) signal from the PCI4510 device. Besides gating  $\overline{PRST}$  and  $\overline{GRST}$ ,  $\overline{SUSPEND}$  also gates PCLK inside the PCI4510 device in order to minimize power consumption.

It should also be noted that asynchronous signals, such as card status change interrupts and  $\overline{\text{RI\_OUT}}$ , can be passed to the host system without a PCI clock. However, if card status change interrupts are routed over the serial interrupt stream, then the PCI clock must be restarted in order to pass the interrupt, because neither the internal oscillator nor an external clock is routed to the serial-interrupt state machine. Figure 3–13 is a signal diagram of the suspend function.

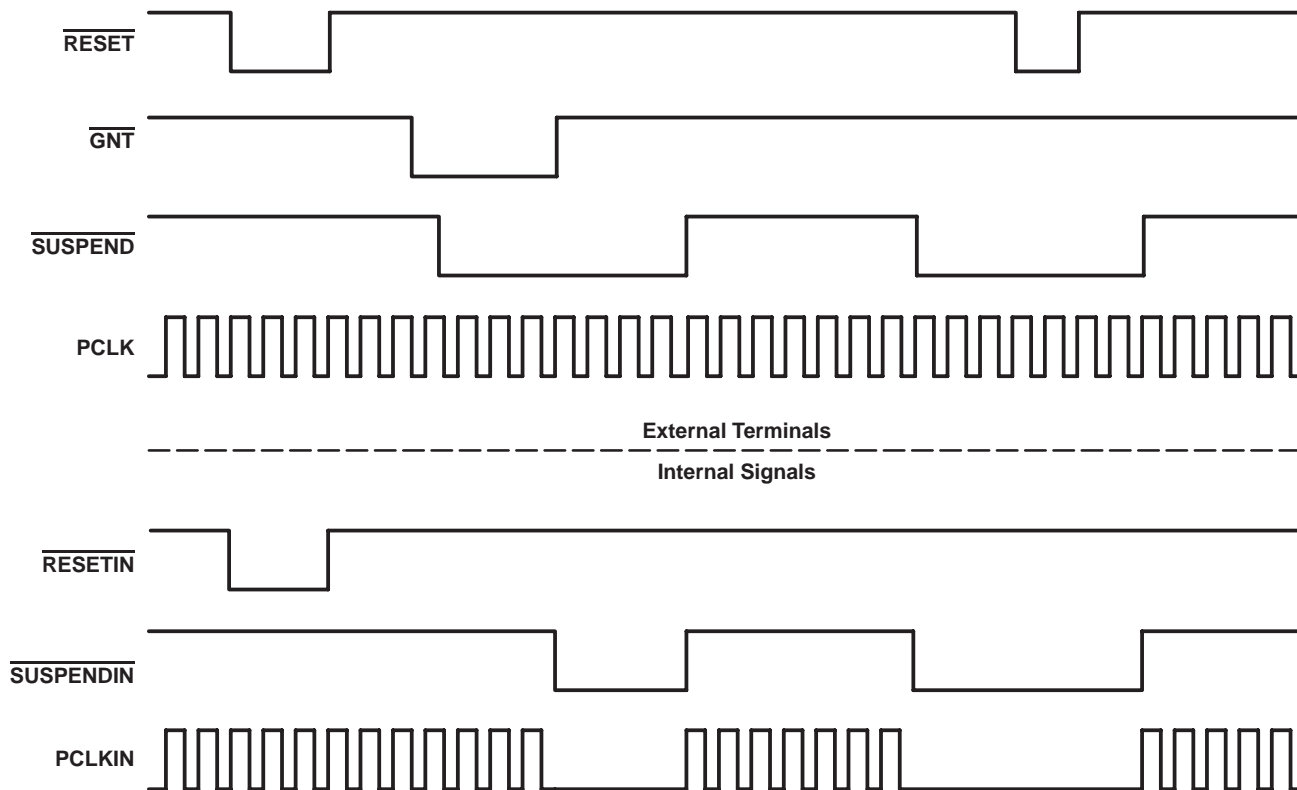

Figure 3–13. Signal Diagram of Suspend Function

### 3.8.7 Requirements for Suspend Mode

The suspend mode prevents the clearing of all register contents on the assertion of reset ( $\overline{\text{PRST}}$  or  $\overline{\text{GRST}}$ ) which would require the reconfiguration of the PCI4510 device by software. Asserting the  $\overline{\text{SUSPEND}}$  signal places the PCI outputs of the controller in a high-impedance state and gates the PCLK signal internally to the controller unless a PCI transaction is currently in process ( $\overline{\text{GNT}}$  is asserted). It is important that the PCI bus not be parked on the PCI4510 device when  $\overline{\text{SUSPEND}}$  is asserted because the outputs are in a high-impedance state.

The GPIOs, MFUNC signals, and  $\overline{\text{RI\_OUT}}$  signal are all active during  $\overline{\text{SUSPEND}}$ , unless they are disabled in the appropriate PCI4510 registers.

### 3.8.8 Ring Indicate

The  $\overline{\text{RI\_OUT}}$  output is an important feature in power management, allowing a system to go into a suspended mode and wake up on modem rings and other card events. TI-designed flexibility permits this signal to fit wide platform requirements.  $\overline{\text{RI\_OUT}}$  on the PCI4510 device can be asserted under any of the following conditions:

- A 16-bit PC Card modem in a powered socket asserts  $\overline{\text{RI}}$  to indicate to the system the presence of an incoming call.
- A powered down CardBus card asserts CSTSCHG (CBWAKE) requesting system and interface wake-up.
- A powered CardBus card asserts CSTSCHG from the insertion/removal of cards or change in battery voltage levels.

Figure 3–14 shows various enable bits for the PCI4510  $\overline{\text{RI\_OUT}}$  function; however, it does not show the masking of CSC events. See Table 3–7 for a detailed description of CSC interrupt masks and flags.

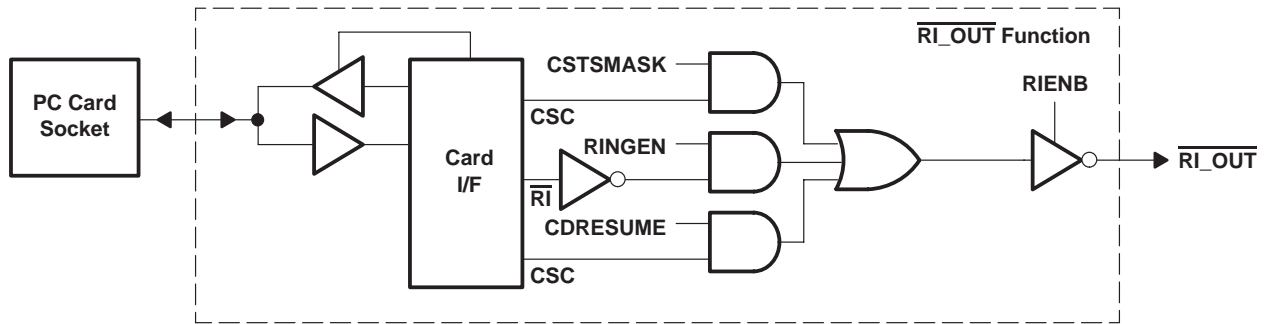

Figure 3–14.  $\overline{\text{RI\_OUT}}$  Functional Diagram

$\overline{\text{RI}}$  from the 16-bit PC Card interface is masked by bit 7 (RINGEN) in the ExCA interrupt and general control register (ExCA offset 03h/803h, see Section 5.4). This is programmed on a per-socket basis and is only applicable when a 16-bit card is powered in the socket.

The CBWAKE signaling to  $\overline{\text{RI\_OUT}}$  is enabled through the same mask as the CSC event for CSTSCHG. The mask bit (bit 0, CSTSMASK) is programmed through the socket mask register (CB offset 04h, see Section 6.2) in the CardBus socket registers.

$\overline{\text{RI\_OUT}}$  can be routed through any of three different pins,  $\overline{\text{RI\_OUT/PME}}$ , MFUNC2, or MFUNC4. The  $\overline{\text{RI\_OUT}}$  function is enabled by setting bit 7 (RIENB) in the card control register (PCI offset 91h, see Section 4.36). The  $\overline{\text{PME}}$  function is enabled by setting bit 8 (PME\_ENABLE) in the power management control/status register (PCI offset A4h, see Section 4.42). When bit 0 (RIMUX) in the system control register (PCI offset 80h, see Section 4.28) is set to 0, both the  $\overline{\text{RI\_OUT}}$  function and the  $\overline{\text{PME}}$  function are routed to the  $\overline{\text{RI\_OUT/PME}}$  terminal. If both functions are enabled and RIMUX is set to 0, then the  $\overline{\text{RI\_OUT/PME}}$  terminal becomes  $\overline{\text{RI\_OUT}}$  only and  $\overline{\text{PME}}$  assertions are never seen. Therefore, in a system using both the  $\overline{\text{RI\_OUT}}$  function and the  $\overline{\text{PME}}$  function, RIMUX must be set to 1 and  $\overline{\text{RI\_OUT}}$  must be routed to either MFUNC2 or MFUNC4.

### 3.8.9 PCI Power Management for CardBus (Function 0)

The *PCI Bus Power Management Interface Specification for PCI to CardBus Bridges* establishes the infrastructure required to let the operating system control the power of PCI functions. This is done by defining a standard PCI interface and operations to manage the power of PCI functions on the bus. The PCI bus and the PCI functions can be assigned one of seven power-management states, resulting in varying levels of power savings.

The seven power-management states of PCI functions are:

- D0-uninitialized – Before device configuration, device not fully functional
- D0-active – Fully functional state
- D1 – Low-power state
- D2 – Low-power state
- D3<sub>hot</sub> – Low-power state. Transition state before D3<sub>cold</sub>
- D3<sub>cold</sub> –  $\overline{\text{PME}}$  signal-generation capable. Main power is removed and VAUX is available.
- D3<sub>off</sub> – No power and completely nonfunctional

NOTE 1: In the D0-uninitialized state, the PCI4510 device does not generate  $\overline{\text{PME}}$  and/or interrupts. When bits 0 (IO\_EN) and 1 (MEM\_EN) of the command register (PCI offset 04h, see Section 4.4) are both set, the PCI4510 device switches the state to D0-active. Transition from D3<sub>cold</sub> to the D0-uninitialized state happens at the deassertion of  $\overline{\text{PRST}}$ . The assertion of  $\overline{\text{GRST}}$  forces the controller to the D0-uninitialized state immediately.

NOTE 2: The PWR\_STATE bits (bits 1–0) of the power-management control/status register (PCI offset A4h, see Section 4.42) only code for four power states, D0, D1, D2, and D3<sub>hot</sub>. The differences between the three D3 states is invisible to the software because the controller is not accessible in the D3<sub>cold</sub> or D3<sub>off</sub> state.

Similarly, bus power states of the PCI bus are B0–B3. The bus power states B0–B3 are derived from the device power state of the originating bridge device.



For the operating system (OS) to manage the device power states on the PCI bus, the PCI function must support four power-management operations. These operations are:

- Capabilities reporting
- Power status reporting
- Setting the power state
- System wake-up

The OS identifies the capabilities of the PCI function by traversing the new capabilities list. The presence of capabilities in addition to the standard PCI capabilities is indicated by a 1 in bit 4 (CAPLIST) of the status register (PCI offset 06h, see Section 4.5).

The capabilities pointer provides access to the first item in the linked list of capabilities. For the PCI4510 device, a CardBus bridge with PCI configuration space header type 2, the capabilities pointer is mapped to an offset of 14h. The first byte of each capability register block is required to be a unique ID of that capability. PCI power management has been assigned an ID of 01h. The next byte is a pointer to the next pointer item in the list of capabilities. If there are no more items in the list, then the next item pointer must be set to 0. The registers following the next item pointer are specific to the capability of the function. The PCI power-management capability implements the register block outlined in Table 3–12.

**Table 3–12. Power-Management Registers**

REGISTER NAME			OFFSET
Power-management capabilities		Next item pointer	A0h
Data	Power-management control/status register bridge support extensions	Power-management control/status (CSR)	A4h

The power management capabilities register (PCI offset A2h, see Section 4.41) provides information on the capabilities of the function related to power management. The power-management control/status register (PCI offset A4h, see Section 4.42) enables control of power-management states and enables/monitors power-management events. The data register is an optional register that can provide dynamic data.

For more information on PCI power management, see the *PCI Bus Power Management Interface Specification for PCI to CardBus Bridges*.

### 3.8.10 CardBus Bridge Power Management

The *PCI Bus Power Management Interface Specification for PCI to CardBus Bridges* was approved by PCMCIA in December of 1997. This specification follows the device and bus state definitions provided in the *PCI Bus Power Management Interface Specification* published by the PCI special interest group (SIG). The main issue addressed in the *PCI Bus Power Management Interface Specification for PCI to CardBus Bridges* is wake-up from D3<sub>hot</sub> or D3<sub>cold</sub> without losing wake-up context (also called  $\overline{\text{PME}}$  context).

The specific issues addressed by the *PCI Bus Power Management Interface Specification for PCI to CardBus Bridges* for D3 wake-up are as follows:

- Preservation of device context. The specification states that a reset must occur during the transition from D3 to D0. Some method to preserve wake-up context must be implemented so that the reset does not clear the  $\overline{\text{PME}}$  context registers.
- Power source in D3<sub>cold</sub> if wake-up support is required from this state.

The Texas Instruments PCI4510 device addresses these D3 wake-up issues in the following manner:

- Two resets are provided to handle preservation of  $\overline{\text{PME}}$  context bits:
  - Global reset ( $\overline{\text{GRST}}$ ) is used only on the initial boot up of the system after power up. It places the PCI4510 device in its default state and requires BIOS to configure the device before becoming fully functional.

- PCI reset ( $\overline{\text{PRST}}$ ) has dual functionality based on whether  $\overline{\text{PME}}$  is enabled or not. If  $\overline{\text{PME}}$  is enabled, then  $\overline{\text{PME}}$  context is preserved. If  $\overline{\text{PME}}$  is not enabled, then  $\overline{\text{PRST}}$  acts the same as a normal PCI reset. Please see the master list of  $\overline{\text{PME}}$  context bits in Section 3.8.12.
- Power source in  $\text{D3}_{\text{cold}}$  if wake-up support is required from this state. Since  $V_{\text{CC}}$  is removed in  $\text{D3}_{\text{cold}}$ , an auxiliary power source must be supplied to the PCI4510  $V_{\text{CC}}$  terminals. Consult the *PCI14xx Implementation Guide for D3 Wake-Up* or the *PCI Power Management Interface Specification for PCI to CardBus Bridges* for further information.

### 3.8.11 ACPI Support

The *Advanced Configuration and Power Interface (ACPI) Specification* provides a mechanism that allows unique pieces of hardware to be described to the ACPI driver. The PCI4510 device offers a generic interface that is compliant with ACPI design rules.

Two doublewords of general-purpose ACPI programming bits reside in PCI4510 PCI configuration space at offset 88h. The programming model is broken into status and control functions. In compliance with ACPI, the top level event status and enable bits reside in the general-purpose event status register (PCI offset 88h, see Section 4.30) and general-purpose event enable register (PCI offset 89h, see Section 4.31). The status and enable bits are implemented as defined by ACPI and illustrated in Figure 3–15.

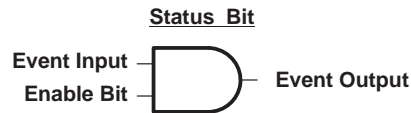

**Figure 3–15. Block Diagram of a Status/Enable Cell**

The status and enable bits generate an event that allows the ACPI driver to call a control method associated with the pending status bit. The control method can then control the hardware by manipulating the hardware control bits or by investigating child status bits and calling their respective control methods. A hierarchical implementation would be somewhat limiting, however, as upstream devices would have to remain in some level of power state to report events.

For more information of ACPI, see the *Advanced Configuration and Power Interface (ACPI) Specification*.

### 3.8.12 Master List of $\overline{\text{PME}}$ Context Bits and Global Reset-Only Bits for CardBus (Function 0)

If the  $\overline{\text{PME}}$  enable bit (bit 8) of the power-management control/status register (PCI offset A4h, see Section 4.42) is asserted, then the assertion of  $\overline{\text{PRST}}$  does not clear the following  $\overline{\text{PME}}$  context bits. If the  $\overline{\text{PME}}$  enable bit is not asserted, then the  $\overline{\text{PME}}$  context bits are cleared with  $\overline{\text{PRST}}$ . The  $\overline{\text{PME}}$  context bits are:

- Bridge control register (PCI offset 3Eh): bit 6
- System control register (PCI offset 80h): bits 10, 9, 8
- Power management CSR register (PCI offset A4h): bit 15, 8
- ExCA power control register (ExCA offset 802h): bits 7, 5 (82365SL mode only), 4–3, 1–0
- ExCA interrupt and general control register (ExCA offset 803h): bits 6–5
- ExCA card status register (ExCA offset 804h): bits 3–0
- ExCA card status change interrupt configuration register (ExCA offset 805h): bits 3–0
- CardBus socket event register (CardBus offset 00h): bits 3–0
- CardBus socket mask register (CardBus offset 04h): bits 3–0
- CardBus socket present state register (CardBus offset 08h): bits 27, 13–7, 5–1
- CardBus socket control register (CardBus offset 10h): bits 6–4, 2–0

Global reset places all registers in their default state regardless of the state of the  $\overline{\text{PME}}$  enable bit. The  $\overline{\text{GRST}}$  signal is gated only by the  $\overline{\text{SUSPEND}}$  signal. This means that assertion of  $\overline{\text{SUSPEND}}$  blocks the  $\overline{\text{GRST}}$  signal internally, thus preserving all register contents. The registers cleared only by  $\overline{\text{GRST}}$  are:

- Status register (PCI offset 06h): bits 15–11, 8

- Secondary status register (PCI offset 16h): bits 15–11, 8
- CardBus subsystem vendor ID register (PCI offset 42h)
- CardBus subsystem ID register (PCI offset 40h)
- PC Card 16-bit I/F legacy mode base address register (PCI offset 44h)
- System control register (PCI offset 80h): bits 31–28, 26–24, 22–13, 11, 6–0
- General control register (PCI offset 86h): bits 15–14, 10, 3, 1–0
- General-purpose event status register (PCI offset 88h): bits 7–6, 4–0
- General-purpose event enable register (PCI offset 89h): bits 7–6, 4–0
- General-purpose output register (PCI offset 8Bh): bits 4–0
- Multifunction routing register (PCI offset 8Ch)
- Retry status register (PCI offset 90h): bits 7–5, 3, 1
- Card control register (PCI offset 91h)
- Device control register (PCI offset 92h): bits 7–5, 3–0
- Diagnostic register (PCI offset 93h)
- Socket DMA register 0 (PCI offset 94h): bits 1–0
- Socket DMA register 1 (PCI offset 98h): bits 15–4, 2–0
- Power management capabilities register (PCI offset A2h): bit 15
- Serial bus data register (PCI offset B0h)
- Serial bus index register (PCI offset B1h)
- Serial bus slave address register (PCI offset B2h)
- Serial bus control/status register (PCI offset B3h): bits 7, 5–0
- ExCA identification and revision register (ExCA offset 800h)
- ExCA global control register (ExCA offset 81Eh): bits 2–0
- CardBus socket power management register (CardBus offset 20h): bits 25–24

### 3.8.13 Master List of Global Reset-Only Bits for 1394 OHCI (Function 1)

Global reset places all registers in their default state regardless of the state of the  $\overline{\text{PME}}$  enable bit. The  $\overline{\text{GRST}}$  signal is gated only by the  $\text{SUSPEND}$  signal. This means that assertion of  $\text{SUSPEND}$  blocks the  $\overline{\text{GRST}}$  signal internally, thus preserving all register contents. The registers cleared only by  $\overline{\text{GRST}}$  are:

- CIS offset register (PCI offset 28h): bits 7–3
- Subsystem vendor ID register (PCI offset 2Ch)
- Subsystem ID register (PCI offset 2Eh)
- Maximum latency/minimum grant register (PCI offset 3Eh)
- Power management control and status register (PCI offset 48h): bits 15, 8, 1, 0
- PHY control register (PCI offset ECh): bits 7, 4–0
- Miscellaneous configuration register (PCI offset F0h): bits 15, 10–8, 5–0
- Link enhancement control register (PCI offset F4h): bits 15–12, 10, 8–7, 2–1
- OHCI bus options register (OHCI offset 20h): bits 15–12
- OHCI GUID Hi register (OHCI offset 24h)
- OHCI GUID Lo register (OHCI offset 28h)
- OHCI Host controller control set/clear (OHCI offset 50h/54h): bit 23
- OHCI link control set/clear (OHCI offset E0h/E4h): bit 6
- PHY-Link loopback test register (local offset C14h): bits 6–4, 0
- Link test control register (local offset C00h): bits 12–8

## 3.9 Low-Voltage CardBus Card Detection

The card detection logic of PCI4510 device include the detection of Cardbus cards with  $V_{CC} = 3.3 \text{ V}$  and  $V_{PP}/V_{CORE} = 1.8 \text{ V}$ . The reporting of the 1.8-V CardBus card ( $V_{CC} = 3.3 \text{ V}$ ,  $V_{PP}/V_{CORE} = 1.8 \text{ V}$ ) is reported through the socket present state register as follows based on bit 10 ( $12V\_SW\_SEL$ ) in the general control register (PCI offset 86h, see Section 4.29):

- If the  $12V\_SW\_SEL$  bit is 0 (TPS2221 is used), then the 1.8-V CardBus card causes the  $3VCARD$  bit in the socket present state register to be set.

- If the 12V\_SW\_SEL bit is 1 (TPS2211A is used), then the 1.8-V CardBus card causes the XVCARD bit in the socket present state register to be set.

### 3.10 Power Switch Interface

The power switch interface of the PCI4510 device is a 4-pin parallel interface. This 4-pin interface is implemented such that the PCI4510 device can connect to both the TPS2211A and TPS2221 power switches. Bit 10 (12V\_SW\_SEL) in the general control register (PCI offset 86h, see Section 4.29) selects the power switch that is implemented. The PCI4510 device defaults to use the control logic for the TPS2221 power switch. See Table 3–13 and Table 3–14 below for the power switch control logic.

**Table 3–13. TPS2221 Control Logic**

VD0/VCCD1	VD1/VCCD0	VD2/VPPD1	VD3/VPPD0	VCC	VPP/VCORE
0	0	0	0	0V	0V
0	0	0	1	Hi-Z	Hi-Z
0	0	1	0	Hi-Z	Hi-Z
0	0	1	1	Hi-Z	Hi-Z
0	1	0	0	3.3V	0V
0	1	0	1	3.3V	3.3V
0	1	1	0	3.3V	5V
0	1	1	1	3.3V	1.8V
1	0	0	0	5V	0V
1	0	0	1	5V	3.3V
1	0	1	0	5V	5V
1	0	1	1	5V	1.8V
1	1	0	0	Hi-Z	Hi-Z
1	1	0	1	3.3V	Hi-Z
1	1	1	0	5V	Hi-Z
1	1	1	1	Hi-Z	Hi-Z

**Table 3–14. TPS2211A Control Logic**

VD0/VCCD1	VD1/VCCD0	VD2/VPPD1	VD3/VPPD0	VCC	VPP/VCORE
0	0	0	0	0V	0V
0	0	0	1	0V	12V
0	0	1	0	0V	0V
0	0	1	1	0V	Hi-Z
0	1	0	0	3.3V	0V
0	1	0	1	3.3V	12V
0	1	1	0	3.3V	3.3V
0	1	1	1	3.3V	Hi-Z
1	0	0	0	5V	0V
1	0	0	1	5V	12V
1	0	1	0	5V	5V
1	0	1	1	5V	Hi-Z
1	1	0	0	0V	0V
1	1	0	1	0V	12V
1	1	1	0	0V	0V
1	1	1	1	0V	Hi-Z

### 3.11 IEEE 1394 Application Information

#### 3.11.1 PHY Port Cable Connection

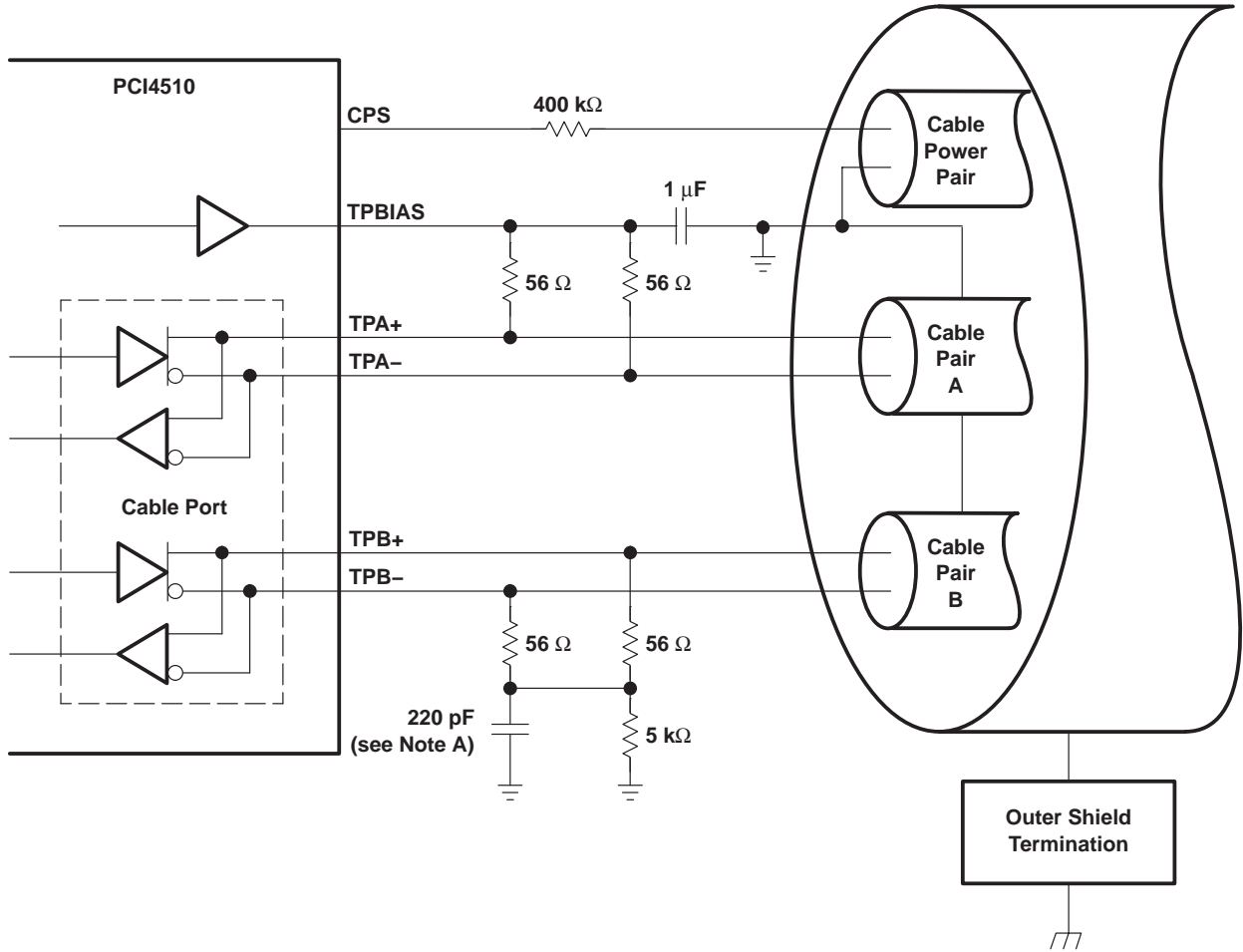

NOTE A: IEEE Std 1394-1995 calls for a 250-pF capacitor, which is a nonstandard component value. A 220-pF capacitor is recommended.

**Figure 3–16. TP Cable Connections**

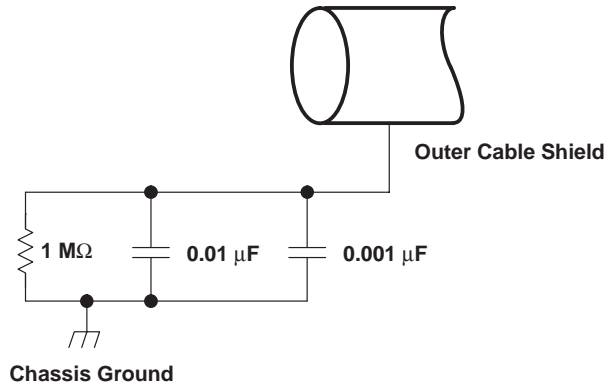

**Figure 3–17. Typical Compliant DC Isolated Outer Shield Termination**

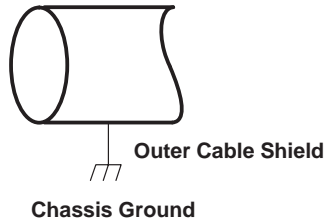

**Figure 3–18. Non-DC Isolated Outer Shield Termination**

### 3.11.2 Crystal Selection

The PCI4510 device is designed to use an external 24.576-MHz crystal connected between the XI and XO terminals to provide the reference for an internal oscillator circuit. This oscillator in turn drives a PLL circuit that generates the various clocks required for transmission and resynchronization of data at the S100 through S400 media data rates.

A variation of less than  $\pm 100$  ppm from nominal for the media data rates is required by IEEE Std 1394-1995. Adjacent PHYs may therefore have a difference of up to 200 ppm from each other in their internal clocks, and PHY devices must be able to compensate for this difference over the maximum packet length. Large clock variations may cause resynchronization overflows or underflows, resulting in corrupted packet data.

The following are some typical specifications for crystals used with the PHYs from TI in order to achieve the required frequency accuracy and stability:

- Crystal mode of operation: Fundamental
- Frequency tolerance @ 25°C: Total frequency variation for the complete circuit is  $\pm 100$  ppm. A crystal with  $\pm 30$  ppm frequency tolerance is recommended for adequate margin.
- Frequency stability (over temperature and age): A crystal with  $\pm 30$  ppm frequency stability is recommended for adequate margin.

**NOTE:** The total frequency variation must be kept below  $\pm 100$  ppm from nominal with some allowance for error introduced by board and device variations. Trade-offs between frequency tolerance and stability may be made as long as the total frequency variation is less than  $\pm 100$  ppm. For example, the frequency tolerance of the crystal may be specified at 50 ppm and the temperature tolerance may be specified at 30 ppm to give a total of 80 ppm possible variation due to the crystal alone. Crystal aging also contributes to the frequency variation.

- Load capacitance: For parallel resonant mode crystal circuits, the frequency of oscillation is dependent upon the load capacitance specified for the crystal. Total load capacitance ( $C_L$ ) is a function of not only the discrete load capacitors, but also board layout and circuit. It is recommended that load capacitors with a maximum of  $\pm 5\%$  tolerance be used.

For example, load capacitors (C9 and C10 in Figure 3–19) of 16 pF each were appropriate for the layout of the PCI4510 evaluation module (EVM), which uses a crystal specified for 12-pF loading. The load specified for the crystal includes the load capacitors (C9 and C10), the loading of the PHY pins ( $C_{PHY}$ ), and the loading of the board itself ( $C_{BD}$ ). The value of  $C_{PHY}$  is typically about 1 pF, and  $C_{BD}$  is typically 0.8 pF per centimeter of board etch; a *typical* board can have 3 pF to 6 pF or more. The load capacitors C9 and C10 combine as capacitors in series so that the total load capacitance is:

$$C_L = \frac{C_9 \times C_{10}}{C_9 + C_{10}} + C_{PHY} + C_{BD}$$

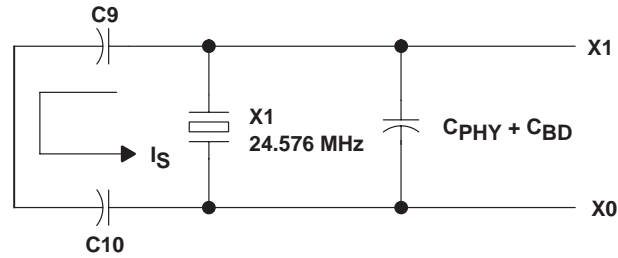

**Figure 3–19. Load Capacitance for the PCI4510 PHY**

The layout of the crystal portion of the PHY circuit is important for obtaining the correct frequency, minimizing noise introduced into the PHY phase-lock loop, and minimizing any emissions from the circuit. The crystal and two load capacitors must be considered as a unit during layout. The crystal and the load capacitors must be placed as close as possible to one another while minimizing the loop area created by the combination of the three components. Varying the size of the capacitors may help in this. Minimizing the loop area minimizes the effect of the resonant current ( $I_S$ ) that flows in this resonant circuit. This layout unit (crystal and load capacitors) must then be placed as close as possible to the PHY X1 and X0 terminals to minimize etch lengths, as shown in Figure 3–20.

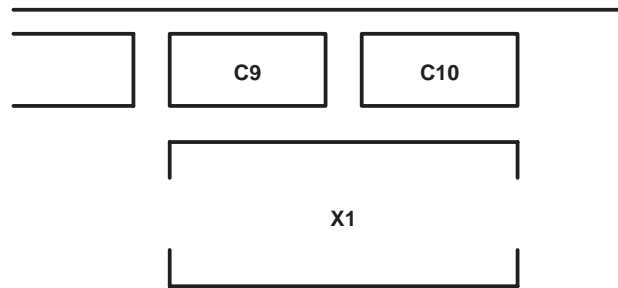

For more details on crystal selection, see application report SLLA051 available from the TI website: <http://www.ti.com/sc/1394>.

**Figure 3–20. Recommended Crystal and Capacitor Layout**

### 3.11.3 Bus Reset

In the PCI4510 device, the initiate bus reset (IBR) bit may be set to 1 in order to initiate a bus reset and initialization sequence. The IBR bit is located in PHY register 1, along with the root-holdoff bit (RHB) and Gap\_Count field, as required by IEEE Std 1394a-2000. Therefore, whenever the IBR bit is written, the RHB and Gap\_Count are also written.

The RHB and Gap\_Count may also be updated by PHY-config packets. The PCI4510 device is IEEE 1394a-2000 compliant, and therefore both the reception and transmission of PHY-config packets cause the RHB and Gap\_Count to be loaded, unlike older IEEE 1394-1995 compliant PHY devices which decode only received PHY-config packets.

The gap-count is set to the maximum value of 63 after 2 consecutive bus resets without an intervening write to the Gap\_Count, either by a write to PHY register 1 or by a PHY-config packet. This mechanism allows a PHY-config packet to be transmitted and then a bus reset initiated so as to verify that all nodes on the bus have updated their RHBs and Gap\_Count values, without having the Gap\_Count set back to 63 by the bus reset. The subsequent connection of a new node to the bus, which initiates a bus reset, then causes the Gap\_Count of each node to be set to 63. Note, however, that if a subsequent bus reset is instead initiated by a write to register 1 to set the IBR bit, all other nodes on the bus have their Gap\_Count values set to 63, while this node Gap\_Count remains set to the value just loaded by the write to PHY register 1.

Therefore, in order to maintain consistent gap-counts throughout the bus, the following rules apply to the use of the IBR bit, RHB, and Gap\_Count in PHY register 1:

- Following the transmission of a PHY-config packet, a bus reset must be initiated in order to verify that all nodes have correctly updated their RHBs and Gap\_Count values and to ensure that a subsequent new connection to the bus causes the Gap\_Count to be set to 63 on all nodes in the bus. If this bus reset is initiated by setting the IBR bit to 1, then the RHB and Gap\_Count field must also be loaded with the correct values consistent with the just-transmitted PHY-config packet. In the PCI4510 device, the RHB and Gap\_Count are updated to their correct values upon the transmission of the PHY-config packet, so these values may first be read from register 1 and then rewritten.
- Other than to initiate the bus reset, which must follow the transmission of a PHY-config packet, whenever the IBR bit is set to 1 in order to initiate a bus reset, the Gap\_Count value must also be set to 63 so as to be consistent with other nodes on the bus, and the RHB must be maintained with its current value.
- The PHY register 1 must not be written to except to set the IBR bit. The RHB and Gap\_Count must not be written without also setting the IBR bit to 1.



## 4 PC Card Controller Programming Model

This chapter describes the PCI4510 PCI configuration registers that make up the 256-byte PCI configuration header for each PCI4510 function.

A bit description table, typically included when the register contains bits of more than one type or purpose, indicates bit field names, a detailed field description, and field access tags which appear in the *type* column. Table 4–1 describes the field access tags.

**Table 4–1. Bit Field Access Tag Descriptions**

ACCESS TAG	NAME	MEANING
R	Read	Field can be read by software.
W	Write	Field can be written by software to any value.
S	Set	Field can be set by a write of 1. Writes of 0 have no effect.
C	Clear	Field can be cleared by a write of 1. Writes of 0 have no effect.
U	Update	Field can be autonomously updated by the PCI4510 device.

### 4.1 PCI Configuration Registers (Function 0)

The PCI4510 device is a multifunction PCI device, and the PC Card controller is integrated as PCI function 0. The configuration header, compliant with the *PCI Local Bus Specification* as a CardBus bridge header, is *PC99/PC2001* compliant as well. Table 4–2 illustrates the PCI configuration header, which includes both the predefined portion of the configuration space and the user-definable registers.

**Table 4–2. Function 0 PCI Configuration Register Map**

REGISTER NAME				OFFSET
Device ID		Vendor ID		00h
Status		Command		04h
Class code			Revision ID	08h
BIST	Header type	Latency timer	Cache line size	0Ch
CardBus socket registers/ExCA base address register				10h
Secondary status		Reserved	Capability pointer	14h
CardBus latency timer	Subordinate bus number	CardBus bus number	PCI bus number	18h
CardBus memory base register 0				1Ch
CardBus memory limit register 0				20h
CardBus memory base register 1				24h
CardBus memory limit register 1				28h
CardBus I/O base register 0				2Ch
CardBus I/O limit register 0				30h
CardBus I/O base register 1				34h
CardBus I/O limit register 1				38h
Bridge control		Interrupt pin	Interrupt line	3Ch
Subsystem ID		Subsystem vendor ID		40h
PC Card 16-bit I/F legacy-mode base-address				44h
Reserved				48h–7Ch
System control				80h

**Table 4–2. Function 0 PCI Configuration Register Map (Continued)**

REGISTER NAME				OFFSET
General control		Reserved		84h
General-purpose output	General-purpose input	General-purpose event enable	General-purpose event status	88h
Multifunction routing status†				8Ch
Diagnostic	Device control	Card control	Retry status	90h
Reserved				94h–9Ch
Power management capabilities		Next item pointer	Capability ID	A0h
Data (Reserved)	Power management control/status register bridge support extensions	Power management control/status		A4h
Reserved				A8h–ACh
Serial bus control/status	Serial bus slave address	Serial bus index	Serial bus data	B0h
Reserved				B4h–FCh

## 4.2 Vendor ID Register

The vendor ID register contains a value allocated by the PCI SIG that identifies the manufacturer of the PCI device. The vendor ID assigned to Texas Instruments is 104Ch.

Bit	15	14	13	12	11	10	9	8	7	6	5	4	3	2	1	0
Name	Vendor ID															
Type	R	R	R	R	R	R	R	R	R	R	R	R	R	R	R	R
Default	0	0	0	1	0	0	0	0	0	1	0	0	1	1	0	0

Register: **Vendor ID**  
 Offset: 00h (Function 0)  
 Type: Read-only  
 Default: 104Ch

## 4.3 Device ID Register

The device ID register contains a value assigned to the PCI4510 device by Texas Instruments. The device identification for the PCI4510 device is AC44h.

Bit	15	14	13	12	11	10	9	8	7	6	5	4	3	2	1	0
Name	Device ID															
Type	R	R	R	R	R	R	R	R	R	R	R	R	R	R	R	R
Default	1	0	1	0	1	1	0	0	0	1	0	0	0	1	0	0

Register: **Device ID**  
 Offset: 02h (Function 0)  
 Type: Read-only  
 Default: AC44h

## 4.4 Command Register

The PCI command register provides control over the PCI4510 interface to the PCI bus. All bit functions adhere to the definitions in the *PCI Local Bus Specification* (see Table 4–3). None of the bit functions in this register are shared among the PCI4510 PCI functions. Three command registers exist in the PCI4510 device, one for each function. Software manipulates the PCI4510 functions as separate entities when enabling functionality through the command register. The SERR\_EN and PERR\_EN enable bits in this register are internally wired OR between the three functions, and these control bits appear to software to be separate for each function.

Bit	15	14	13	12	11	10	9	8	7	6	5	4	3	2	1	0
Name	Command															
Type	R	R	R	R	R	R	R	RW	R	RW	RW	R	R	RW	RW	RW
Default	0	0	0	0	0	0	0	0	0	0	0	0	0	0	0	0

Register: **Command**  
 Offset: 04h  
 Type: Read-only, Read/Write  
 Default: 0000h

**Table 4–3. Command Register Description**

BIT	SIGNAL	TYPE	FUNCTION
15–10	RSVD	R	Reserved. Bits 15–10 return 0s when read.
9	FBB_EN	R	Fast back-to-back enable. The PCI4510 device does not generate fast back-to-back transactions; therefore, this bit is read-only. This bit returns a 0 when read.
8	SERR_EN	RW	System error (SERR) enable. This bit controls the enable for the SERR driver on the PCI interface. SERR can be asserted after detecting an address parity error on the PCI bus. Both this bit and bit 6 must be set to 1 for the PCI4510 device to report address parity errors. 0 = Disables the SERR output driver (default) 1 = Enables the SERR output driver
7	STEP_EN	R	Address/data stepping control. The PCI4510 device does not support address/data stepping, and this bit is hardwired to 0. Writes to this bit have no effect.
6	PERR_EN	RW	Parity error response enable. This bit controls the PCI4510 device response to parity errors through the PERR signal. Data parity errors are indicated by asserting PERR, while address parity errors are indicated by asserting SERR. 0 = PCI4510 device ignores detected parity errors (default). 1 = PCI4510 device responds to detected parity errors.
5	VGA_EN	RW	VGA palette snoop. When set to 1, palette snooping is enabled (that is, the PCI4510 device does not respond to palette register writes and snoops the data). When the bit is 0, the PCI4510 device treats all palette accesses like all other accesses.
4	MWI_EN	R	Memory write-and-invalidate enable. This bit controls whether a PCI initiator device can generate memory write-and-invalidate commands. The PCI4510 controller does not support memory write-and-invalidate commands, it uses memory write commands instead; therefore, this bit is hardwired to 0. This bit returns 0 when read. Writes to this bit have no effect.
3	SPECIAL	R	Special cycles. This bit controls whether or not a PCI device ignores PCI special cycles. The PCI4510 device does not respond to special cycle operations; therefore, this bit is hardwired to 0. This bit returns 0 when read. Writes to this bit have no effect.
2	MAST_EN	RW	Bus master control. This bit controls whether or not the PCI4510 device can act as a PCI bus initiator (master). The PCI4510 device can take control of the PCI bus only when this bit is set. 0 = Disables the PCI4510 ability to generate PCI bus accesses (default) 1 = Enables the PCI4510 ability to generate PCI bus accesses
1	MEM_EN	RW	Memory space enable. This bit controls whether or not the PCI4510 device can claim cycles in PCI memory space. 0 = Disables the PCI4510 response to memory space accesses (default) 1 = Enables the PCI4510 response to memory space accesses
0	IO_EN	RW	I/O space control. This bit controls whether or not the PCI4510 device can claim cycles in PCI I/O space. 0 = Disables the PCI4510 device from responding to I/O space accesses (default) 1 = Enables the PCI4510 device to respond to I/O space accesses

## 4.5 Status Register

The status register provides device information to the host system. Bits in this register can be read normally. A bit in the status register is reset when a 1 is written to that bit location; a 0 written to a bit location has no effect. All bit functions adhere to the definitions in the *PCI Bus Specification*, as seen in the bit descriptions. PCI bus status is shown through each function. See Table 4–4 for a complete description of the register contents.

Bit	15	14	13	12	11	10	9	8	7	6	5	4	3	2	1	0
Name	Status															
Type	RW	RW	RW	RW	RW	R	R	RW	R	R	R	R	R	R	R	R
Default	0	0	0	0	0	0	1	0	0	0	0	1	0	0	0	0

Register: **Status**  
 Offset: 06h (Function 0)  
 Type: Read-only, Read/Write  
 Default: 0210h

**Table 4–4. Status Register Description**

BIT	SIGNAL	TYPE	FUNCTION
15	PAR_ERR	RW	Detected parity error. This bit is set when a parity error is detected, either an address or data parity error. Write a 1 to clear this bit.
14	SYS_ERR	RW	Signaled system error. This bit is set when $\overline{SERR}$ is enabled and the PCI4510 device signaled a system error to the host. Write a 1 to clear this bit.
13	MABORT	RW	Received master abort. This bit is set when a cycle initiated by the PCI4510 device on the PCI bus has been terminated by a master abort. Write a 1 to clear this bit.
12	TABT_REC	RW	Received target abort. This bit is set when a cycle initiated by the PCI4510 device on the PCI bus was terminated by a target abort. Write a 1 to clear this bit.
11	TABT_SIG	RW	Signaled target abort. This bit is set by the PCI4510 device when it terminates a transaction on the PCI bus with a target abort. Write a 1 to clear this bit.
10–9	PCI_SPEED	R	DEVSEL timing. These bits encode the timing of $\overline{DEVSEL}$ and are hardwired to 01b indicating that the PCI4510 device asserts this signal at a medium speed on nonconfiguration cycle accesses.
8	DATAPAR	RW	Data parity error detected. Write a 1 to clear this bit. 0 = The conditions for setting this bit have not been met. 1 = A data parity error occurred and the following conditions were met: a. $\overline{PERR}$ was asserted by any PCI device including the PCI4510 device. b. The PCI4510 device was the bus master during the data parity error. c. The parity error response bit is set in the command register (PCI offset 04h, see Section 4.4).
7	FBB_CAP	R	Fast back-to-back capable. The PCI4510 device cannot accept fast back-to-back transactions; thus, this bit is hardwired to 0.
6	UDF	R	UDF supported. The PCI4510 device does not support user-definable features; therefore, this bit is hardwired to 0.
5	66MHZ	R	66-MHz capable. The PCI4510 device operates at a maximum PCLK frequency of 33 MHz; therefore, this bit is hardwired to 0.
4	CAPLIST	R	Capabilities list. This bit returns 1 when read. This bit indicates that capabilities in addition to standard PCI capabilities are implemented. The linked list of PCI power-management capabilities is implemented in this function.
3–0	RSVD	R	These bits return 0s when read.

## 4.6 Class Code and Revision ID Registers

The class code and revision ID register recognizes the PCI4510 device as a bridge device (06h) and CardBus bridge device (07h) with a (00h) programming interface. Furthermore, the TI chip revision (02h) is indicated in the least significant byte.

Bit	31	30	29	28	27	26	25	24	23	22	21	20	19	18	17	16
Name	Class code															
Type	R	R	R	R	R	R	R	R	R	R	R	R	R	R	R	R
Default	0	0	0	0	0	1	1	0	0	0	0	0	0	1	1	1
Bit	15	14	13	12	11	10	9	8	7	6	5	4	3	2	1	0
Name	Class code								Revision ID							
Type	R	R	R	R	R	R	R	R	R	R	R	R	R	R	R	R
Default	0	0	0	0	0	0	0	0	0	0	0	0	0	0	1	0

Register: **Class code and revision ID**  
 Offset: 08h (Function 0)  
 Type: Read-only  
 Default: 0607 0002h

## 4.7 Cache Line Size Register

The cache line size register is programmed by host software to indicate the system cache line size.

Bit	7	6	5	4	3	2	1	0
Name	Cache line size							
Type	RW	RW	RW	RW	RW	RW	RW	RW
Default	0	0	0	0	0	0	0	0

Register: **Cache line size**  
 Offset: 0Ch (Function 0)  
 Type: Read/Write  
 Default: 00h

## 4.8 Latency Timer Register

The latency timer register specifies the latency timer for the PCI4510 device, in units of PCI clock cycles. When the PCI4510 device is a PCI bus initiator and asserts  $\overline{\text{FRAME}}$ , the latency timer begins counting from zero. If the latency timer expires before the PCI4510 transaction has terminated, then the PCI4510 device terminates the transaction when its  $\overline{\text{GNT}}$  is deasserted.

Bit	7	6	5	4	3	2	1	0
Name	Latency timer							
Type	RW	RW	RW	RW	RW	RW	RW	RW
Default	0	0	0	0	0	0	0	0

Register: **Latency timer**  
 Offset: 0Dh  
 Type: Read/Write  
 Default: 00h

## 4.9 Header Type Register

The header type register returns 82h when read, indicating that the PCI4510 configuration spaces adhere to the CardBus bridge PCI header. The CardBus bridge PCI header ranges from PCI registers 00h–7Fh, and 80h–FFh is user-definable extension registers.

Bit	7	6	5	4	3	2	1	0
Name	Header type							
Type	R	R	R	R	R	R	R	R
Default	1	0	0	0	0	0	1	0

Register: **Header type**  
 Offset: 0Eh (Function 0)  
 Type: Read-only  
 Default: 82h

## 4.10 BIST Register

Because the PCI4510 device does not support a built-in self-test (BIST), this register returns the value of 00h when read.

Bit	7	6	5	4	3	2	1	0
Name	BIST							
Type	R	R	R	R	R	R	R	R
Default	0	0	0	0	0	0	0	0

Register: **BIST**  
 Offset: 0Fh (Function 0)  
 Type: Read-only  
 Default: 00h

## 4.11 CardBus Socket Registers/ExCA Base Address Register

This register is programmed with a base address referencing the CardBus socket registers and the memory-mapped ExCA register set. Bits 31–12 are read/write, and allow the base address to be located anywhere in the 32-bit PCI memory address space on a 4-Kbyte boundary. Bits 11–0 are read-only, returning 0s when read. When software writes all 1s to this register, the value read back is FFFF F000h, indicating that at least 4K bytes of memory address space are required. The CardBus registers start at offset 000h, and the memory-mapped ExCA registers begin at offset 800h. The system maps each socket control register separately.

Bit	31	30	29	28	27	26	25	24	23	22	21	20	19	18	17	16
Name	CardBus socket registers/ExCA base address															
Type	RW	RW	RW	RW	RW	RW	RW	RW	RW	RW	RW	RW	RW	RW	RW	RW
Default	0	0	0	0	0	0	0	0	0	0	0	0	0	0	0	0
Bit	15	14	13	12	11	10	9	8	7	6	5	4	3	2	1	0
Name	CardBus socket registers/ExCA base address															
Type	RW	RW	RW	RW	R	R	R	R	R	R	R	R	R	R	R	R
Default	0	0	0	0	0	0	0	0	0	0	0	0	0	0	0	0

Register: **CardBus socket registers/ExCA base address**  
 Offset: 10h  
 Type: Read-only, Read/Write  
 Default: 0000 0000h

## 4.12 Capability Pointer Register

The capability pointer register provides a pointer into the PCI configuration header where the PCI power management register block resides. PCI header doublewords at A0h and A4h provide the power management (PM) registers. Each socket has its own capability pointer register. This register is read-only and returns A0h when read.

Bit	7	6	5	4	3	2	1	0
Name	Capability pointer							
Type	R	R	R	R	R	R	R	R
Default	1	0	1	0	0	0	0	0

Register: **Capability pointer**  
Offset: 14h  
Type: Read-only  
Default: A0h

### 4.13 Secondary Status Register

The secondary status register is compatible with the PCI-PCI bridge secondary status register. It indicates CardBus-related device information to the host system. This register is very similar to the PCI status register (PCI offset 06h, see Section 4.5), and status bits are cleared by a writing a 1. This register is not shared by the two socket functions, but is accessed on a per-socket basis. See Table 4–5 for a complete description of the register contents.

Bit	15	14	13	12	11	10	9	8	7	6	5	4	3	2	1	0
Name	Secondary status															
Type	RC	RC	RC	RC	RC	R	R	RC	R	R	R	R	R	R	R	R
Default	0	0	0	0	0	0	1	0	0	0	0	0	0	0	0	0

Register: **Secondary status**  
 Offset: 16h  
 Type: Read-only, Read/Clear  
 Default: 0200h

**Table 4–5. Secondary Status Register Description**

BIT	SIGNAL	TYPE	FUNCTION
15	CBPARITY	RC	Detected parity error. This bit is set when a CardBus parity error is detected, either an address or data parity error. Write a 1 to clear this bit.
14	CBSERR	RC	Signaled system error. This bit is set when <u>CSERR</u> is signaled by a CardBus card. The PCI4510 device does not assert the <u>CSERR</u> signal. Write a 1 to clear this bit.
13	CBMABORT	RC	Received master abort. This bit is set when a cycle initiated by the PCI4510 device on the CardBus bus is terminated by a master abort. Write a 1 to clear this bit.
12	REC_CBTA	RC	Received target abort. This bit is set when a cycle initiated by the PCI4510 device on the CardBus bus is terminated by a target abort. Write a 1 to clear this bit.
11	SIG_CBTA	RC	Signaled target abort. This bit is set by the PCI4510 device when it terminates a transaction on the CardBus bus with a target abort. Write a 1 to clear this bit.
10–9	CB_SPEED	R	CDEVSEL timing. These bits encode the timing of <u>CDEVSEL</u> and are hardwired to 01b indicating that the PCI4510 device asserts this signal at a medium speed.
8	CB_DPAR	RC	CardBus data parity error detected. Write a 1 to clear this bit. 0 = The conditions for setting this bit have not been met. 1 = A <u>data parity error</u> occurred and the following conditions were met: a. <u>CPERR</u> was asserted on the CardBus interface. b. The PCI4510 device was the bus master during the data parity error. c. The parity error response enable bit (bit 0) is set in the bridge control register (PCI offset 3Eh, see Section 4.24).
7	CBFBB_CAP	R	Fast back-to-back capable. The PCI4510 device cannot accept fast back-to-back transactions; therefore, this bit is hardwired to 0.
6	CB_UDF	R	User-definable feature support. The PCI4510 device does not support user-definable features; therefore, this bit is hardwired to 0.
5	CB66MHZ	R	66-MHz capable. The PCI4510 CardBus interface operates at a maximum CCLK frequency of 33 MHz; therefore, this bit is hardwired to 0.
4–0	RSVD	R	These bits return 0s when read.



## 4.14 PCI Bus Number Register

The PCI bus number register is programmed by the host system to indicate the bus number of the PCI bus to which the PCI4510 device is connected. The PCI4510 device uses this register in conjunction with the CardBus bus number and subordinate bus number registers to determine when to forward PCI configuration cycles to its secondary buses.

Bit	7	6	5	4	3	2	1	0
<b>Name</b>	PCI bus number							
<b>Type</b>	RW	RW	RW	RW	RW	RW	RW	RW
<b>Default</b>	0	0	0	0	0	0	0	0

Register: **PCI bus number**  
 Offset: 18h (Function 0)  
 Type: Read/Write  
 Default: 00h

## 4.15 CardBus Bus Number Register

The CardBus bus number register is programmed by the host system to indicate the bus number of the CardBus bus to which the PCI4510 device is connected. The PCI4510 device uses this register in conjunction with the PCI bus number and subordinate bus number registers to determine when to forward PCI configuration cycles to its secondary buses. This register is separate for each PCI4510 controller function.

Bit	7	6	5	4	3	2	1	0
<b>Name</b>	CardBus bus number							
<b>Type</b>	RW	RW	RW	RW	RW	RW	RW	RW
<b>Default</b>	0	0	0	0	0	0	0	0

Register: **CardBus bus number**  
 Offset: 19h  
 Type: Read/Write  
 Default: 00h

## 4.16 Subordinate Bus Number Register

The subordinate bus number register is programmed by the host system to indicate the highest numbered bus below the CardBus bus. The PCI4510 device uses this register in conjunction with the PCI bus number and CardBus bus number registers to determine when to forward PCI configuration cycles to its secondary buses. This register is separate for each CardBus controller function.

Bit	7	6	5	4	3	2	1	0
<b>Name</b>	Subordinate bus number							
<b>Type</b>	RW	RW	RW	RW	RW	RW	RW	RW
<b>Default</b>	0	0	0	0	0	0	0	0

Register: **Subordinate bus number**  
 Offset: 1Ah  
 Type: Read/Write  
 Default: 00h

## 4.17 CardBus Latency Timer Register

The CardBus latency timer register is programmed by the host system to specify the latency timer for the PCI4510 CardBus interface, in units of CCLK cycles. When the PCI4510 device is a CardBus initiator and asserts CFRAME, the CardBus latency timer begins counting. If the latency timer expires before the PCI4510 transaction has terminated, then the PCI4510 device terminates the transaction at the end of the next data phase. A recommended minimum value for this register of 20h allows most transactions to be completed.

Bit	7	6	5	4	3	2	1	0
<b>Name</b>	CardBus latency timer							
<b>Type</b>	RW	RW	RW	RW	RW	RW	RW	RW
<b>Default</b>	0	0	0	0	0	0	0	0

Register: **CardBus latency timer**  
 Offset: 1Bh (Function 0)  
 Type: Read/Write  
 Default: 00h

## 4.18 CardBus Memory Base Registers 0, 1

These registers indicate the lower address of a PCI memory address range. They are used by the PCI4510 device to determine when to forward a memory transaction to the CardBus bus, and likewise, when to forward a CardBus cycle to PCI. Bits 31–12 of these registers are read/write and allow the memory base to be located anywhere in the 32-bit PCI memory space on 4-Kbyte boundaries. Bits 11–0 are read-only and always return 0s. Writes to these bits have no effect. Bits 8 and 9 of the bridge control register (PCI offset 3Eh, see Section 4.24) specify whether memory windows 0 and 1 are prefetchable or nonprefetchable. The memory base register or the memory limit register must be nonzero in order for the PCI4510 device to claim any memory transactions through CardBus memory windows (i.e., these windows by default are not enabled to pass the first 4 Kbytes of memory to CardBus).

Bit	31	30	29	28	27	26	25	24	23	22	21	20	19	18	17	16
<b>Name</b>	Memory base registers 0, 1															
<b>Type</b>	RW	RW	RW	RW	RW	RW	RW	RW	RW	RW	RW	RW	RW	RW	RW	RW
<b>Default</b>	0	0	0	0	0	0	0	0	0	0	0	0	0	0	0	0
Bit	15	14	13	12	11	10	9	8	7	6	5	4	3	2	1	0
<b>Name</b>	Memory base registers 0, 1															
<b>Type</b>	RW	RW	RW	RW	R	R	R	R	R	R	R	R	R	R	R	R
<b>Default</b>	0	0	0	0	0	0	0	0	0	0	0	0	0	0	0	0

Register: **Memory base registers 0, 1**  
 Offset: 1Ch, 24h  
 Type: Read-only, Read/Write  
 Default: 0000 0000h

## 4.19 CardBus Memory Limit Registers 0, 1

These registers indicate the upper address of a PCI memory address range. They are used by the PCI4510 device to determine when to forward a memory transaction to the CardBus bus, and likewise, when to forward a CardBus cycle to PCI. Bits 31–12 of these registers are read/write and allow the memory base to be located anywhere in the 32-bit PCI memory space on 4-Kbyte boundaries. Bits 11–0 are read-only and always return 0s. Writes to these bits have no effect. Bits 8 and 9 of the bridge control register (PCI offset 3Eh, see Section 4.24) specify whether memory windows 0 and 1 are prefetchable or nonprefetchable. The memory base register or the memory limit register must be nonzero in order for the PCI4510 device to claim any memory transactions through CardBus memory windows (that is, these windows by default are not enabled to pass the first 4 Kbytes of memory to CardBus).

Bit	31	30	29	28	27	26	25	24	23	22	21	20	19	18	17	16
<b>Name</b>	Memory limit registers 0, 1															
<b>Type</b>	RW	RW	RW	RW	RW	RW	RW	RW	RW	RW	RW	RW	RW	RW	RW	RW
<b>Default</b>	0	0	0	0	0	0	0	0	0	0	0	0	0	0	0	0
Bit	15	14	13	12	11	10	9	8	7	6	5	4	3	2	1	0
<b>Name</b>	Memory limit registers 0, 1															
<b>Type</b>	RW	RW	RW	RW	R	R	R	R	R	R	R	R	R	R	R	R
<b>Default</b>	0	0	0	0	0	0	0	0	0	0	0	0	0	0	0	0

Register: **Memory limit registers 0, 1**

Offset: 20h, 28h

Type: Read-only, Read/Write

Default: 0000 0000h

## 4.20 CardBus I/O Base Registers 0, 1

The I/O base registers indicate the lower address of a PCI I/O address range. These registers are used by the PCI4510 device to determine when to forward an I/O transaction to the CardBus bus, and likewise, when to forward a CardBus cycle to the PCI bus. The lower 16 bits of this register locate the bottom of the I/O window within a 64-Kbyte page. The upper 16 bits (31–16) are a page register which locates this 64-Kbyte page in 32-bit PCI I/O address space. Bits 31–2 are read/write. Bits 1 and 0 are read-only and always return 0s, forcing I/O windows to be aligned on a natural doubleword boundary.

Either the I/O base register or the I/O limit register must be nonzero to enable any I/O transactions.

Bit	31	30	29	28	27	26	25	24	23	22	21	20	19	18	17	16
<b>Name</b>	I/O base registers 0, 1															
<b>Type</b>	RW	RW	RW	RW	RW	RW	RW	RW	RW	RW	RW	RW	RW	RW	RW	RW
<b>Default</b>	0	0	0	0	0	0	0	0	0	0	0	0	0	0	0	0
Bit	15	14	13	12	11	10	9	8	7	6	5	4	3	2	1	0
<b>Name</b>	I/O base registers 0, 1															
<b>Type</b>	RW	RW	RW	RW	RW	RW	RW	RW	RW	RW	RW	RW	RW	RW	R	R
<b>Default</b>	0	0	0	0	0	0	0	0	0	0	0	0	0	0	0	0

Register: **I/O base registers 0, 1**

Offset: 2Ch, 34h

Type: Read-only, Read/Write

Default: 0000 0000h

## 4.21 CardBus I/O Limit Registers 0, 1

These registers indicate the upper address of a PCI I/O address range. They are used by the PCI4510 device to determine when to forward an I/O transaction to the CardBus bus, and likewise, when to forward a CardBus cycle to PCI. The lower 16 bits of this register locate the top of the I/O window within a 64-Kbyte page, and the upper 16 bits are a page register which locates this 64-Kbyte page in 32-bit PCI I/O address space. Bits 15–2 are read/write and allow the I/O limit address to be located anywhere in the 64-Kbyte page (indicated by bits 31–16 of the appropriate I/O base register) on doubleword boundaries.

Bits 31–16 are read-only and always return 0s when read. The page is set in the I/O base register. Bits 1–0 are read-only and always return 0s, forcing I/O windows to be aligned on a natural doubleword boundary. Writes to read-only bits have no effect. The PCI4510 device assumes that the lower 2 bits of the limit address are 1s.

These I/O windows are enabled when either the I/O base register or the I/O limit register is nonzero. By default, the I/O windows are not enabled to pass the first doubleword of I/O to CardBus.

Either the I/O base register or the I/O limit register must be nonzero to enable any I/O transactions.

Bit	31	30	29	28	27	26	25	24	23	22	21	20	19	18	17	16
<b>Name</b>	I/O limit registers 0, 1															
<b>Type</b>	R	R	R	R	R	R	R	R	R	R	R	R	R	R	R	R
<b>Default</b>	0	0	0	0	0	0	0	0	0	0	0	0	0	0	0	0
Bit	15	14	13	12	11	10	9	8	7	6	5	4	3	2	1	0
<b>Name</b>	I/O limit registers 0, 1															
<b>Type</b>	RW	RW	RW	RW	RW	RW	RW	RW	RW	RW	RW	RW	RW	RW	R	R
<b>Default</b>	0	0	0	0	0	0	0	0	0	0	0	0	0	0	0	0

Register: **I/O limit registers 0, 1**  
 Offset: 30h, 38h  
 Type: Read-only, Read/Write  
 Default: 0000 0000h

## 4.22 Interrupt Line Register

The interrupt line register communicates interrupt line routing information to the host system. This register is not used by the PCI4510 device, because there are many programmable interrupt signaling options. This register is considered reserved; however, host software can read and write to this register. Each PCI4510 function has an interrupt line register.

Bit	7	6	5	4	3	2	1	0
<b>Name</b>	Interrupt line							
<b>Type</b>	RW	RW	RW	RW	RW	RW	RW	RW
<b>Default</b>	1	1	1	1	1	1	1	1

Register: **Interrupt line**  
 Offset: 3Ch  
 Type: Read/Write  
 Default: FFh

## 4.23 Interrupt Pin Register

The value read from this register is function dependent, and depends on interrupt tie bit 29 (INTRTIE) in the system control register (PCI offset 80h, see Section 4.28). INTRTIE is compatible with other TI CardBus controllers and ties INTA to INTB internally. The internal interrupt connections set by INTRTIE are communicated to host software through this standard register interface. Refer to Table 4–6 for a complete description of the register contents.

<b>Bit</b>	<b>7</b>	<b>6</b>	<b>5</b>	<b>4</b>	<b>3</b>	<b>2</b>	<b>1</b>	<b>0</b>
<b>Name</b>	Interrupt pin							
<b>Type</b>	R	R	R	R	R	R	R	R
<b>Default</b>	0	0	0	0	0	0	0	1

Register: **Interrupt pin**  
 Offset: 3Dh  
 Type: Read-only  
 Default: 01h

**Table 4–6. PCI Interrupt Pin Register—Read-Only INTPIN Per Function**

INTRTIE BIT	INTPIN FUNCTION 0 (CARDBUS)	INTPIN FUNCTION 1 (1394 OHCI)
0	01h ( $\overline{\text{INTA}}$ )	02h ( $\overline{\text{INTB}}$ )
1	01h ( $\overline{\text{INTA}}$ )	01h ( $\overline{\text{INTA}}$ )

† When configuring the PCI4510 functions to share PCI interrupts, multifunction terminal MFUNC3 must be configured as IRQSER prior to setting the INTRTIE bit.

## 4.24 Bridge Control Register

The bridge control register provides control over various PCI4510 bridging functions. See Table 4–7 for a complete description of the register contents.

Bit	15	14	13	12	11	10	9	8	7	6	5	4	3	2	1	0
Name	Bridge control															
Type	R	R	R	R	R	RW	RW	RW	RW	RW	RW	R	RW	RW	RW	RW
Default	0	0	0	0	0	0	1	1	0	1	0	0	0	0	0	0

Register: **Bridge control**  
 Offset: 3Eh (Function 0)  
 Type: Read-only, Read/Write  
 Default: 0340h

**Table 4–7. Bridge Control Register Description**

BIT	SIGNAL	TYPE	FUNCTION
15–11	RSVD	R	These bits return 0s when read.
10	POSTEN	RW	Write posting enable. Enables write posting to and from the CardBus sockets. Write posting enables the posting of write data on burst cycles. Operating with write posting disabled impairs performance on burst cycles. Note that burst write data can be posted, but various write transactions may not.
9	PREFETCH1	RW	Memory window 1 type. This bit specifies whether or not memory window 1 is prefetchable. This bit is socket dependent. This bit is encoded as: 0 = Memory window 1 is nonprefetchable. 1 = Memory window 1 is prefetchable (default).
8	PREFETCH0	RW	Memory window 0 type. This bit specifies whether or not memory window 0 is prefetchable. This bit is socket dependent. This bit is encoded as: 0 = Memory window 0 is nonprefetchable. 1 = Memory window 0 is prefetchable (default).
7	INTR	RW	PCI interrupt – IREQ routing enable. This bit selects whether PC Card functional interrupts are routed to PCI interrupts or to the IRQ specified in the ExCA registers. 0 = Functional interrupts are routed to PCI interrupts (default). 1 = Functional interrupts are routed by ExCA registers.
6	CRST	RW	CardBus reset. When this bit is set, the $\overline{CRST}$ signal is asserted on the CardBus interface. The $\overline{CRST}$ signal can also be asserted by passing a $\overline{PRST}$ assertion to CardBus. 0 = $\overline{CRST}$ is deasserted. 1 = $\overline{CRST}$ is asserted (default). This bit is not cleared by the assertion of $\overline{PRST}$ . It is only cleared by the assertion of $\overline{GRST}$ .
5	MABTMODE	RW	Master abort mode. This bit controls how the PCI4510 device responds to a master abort when the PCI4510 device is an initiator on the CardBus interface. This bit is common between each socket. 0 = Master aborts not reported (default). 1 = Signal target abort on PCI and signal $\overline{SERR}$ , if enabled.
4	RSVD	R	This bit returns 0 when read.
3	VGAEN	RW	VGA enable. This bit affects how the PCI4510 device responds to VGA addresses. When this bit is set, accesses to VGA addresses are forwarded.
2	ISAEN	RW	ISA mode enable. This bit affects how the PCI4510 device passes I/O cycles within the 64-Kbyte ISA range. This bit is not common between sockets. When this bit is set, the PCI4510 device does not forward the last 768 bytes of each 1K I/O range to CardBus.
1	CSERREN	RW	$\overline{CSERR}$ enable. This bit controls the response of the PCI4510 device to $\overline{CSERR}$ signals on the CardBus bus. This bit is separate for each socket. 0 = $\overline{CSERR}$ is not forwarded to PCI $\overline{SERR}$ (default) 1 = $\overline{CSERR}$ is forwarded to PCI $\overline{SERR}$ .
0	CPERREN	RW	CardBus parity error response enable. This bit controls the response of the PCI4510 device to CardBus parity errors. This bit is separate for each socket. 0 = CardBus parity errors are ignored (default). 1 = CardBus parity errors are reported using $\overline{CPERR}$ .

## 4.25 Subsystem Vendor ID Register

The subsystem vendor ID register, used for system and option card identification purposes, may be required for certain operating systems. This register is read-only or read/write, depending on the setting of bit 5 (SUBSYSRW) in the system control register (PCI offset 80h, see Section 4.28). When bit 5 is 0, this register is read/write; when bit 5 is 1, this register is read-only. The default mode is read-only.

Bit	15	14	13	12	11	10	9	8	7	6	5	4	3	2	1	0
Name	Subsystem vendor ID															
Type	R	R	R	R	R	R	R	R	R	R	R	R	R	R	R	R
Default	0	0	0	0	0	0	0	0	0	0	0	0	0	0	0	0

Register: **Subsystem vendor ID**  
 Offset: 40h (Function 0)  
 Type: Read-only, (Read/Write when bit 5 in the system control register is 0)  
 Default: 0000h

## 4.26 Subsystem ID Register

The subsystem ID register, used for system and option card identification purposes, may be required for certain operating systems. This register is read-only or read/write, depending on the setting of bit 5 (SUBSYSRW) in the system control register (PCI offset 80h, see Section 4.28). When bit 5 is 0, this register is read/write; when bit 5 is 1, this register is read-only. The default mode is read-only.

If a ROM is present, then the subsystem ID and subsystem vendor ID will be loaded from ROM after a reset.

Bit	15	14	13	12	11	10	9	8	7	6	5	4	3	2	1	0
Name	Subsystem ID															
Type	R	R	R	R	R	R	R	R	R	R	R	R	R	R	R	R
Default	0	0	0	0	0	0	0	0	0	0	0	0	0	0	0	0

Register: **Subsystem ID**  
 Offset: 42h (Function 0)  
 Type: Read-only, (Read/Write when bit 5 in the system control register is 0)  
 Default: 0000h

## 4.27 PC Card 16-Bit I/F Legacy-Mode Base-Address Register

The PCI4510 device supports the index/data scheme of accessing the ExCA registers, which is mapped by this register. An address written to this register is the address for the index register and the address+1 is the data address. Using this access method, applications requiring index/data ExCA access can be supported. The base address can be mapped anywhere in 32-bit I/O space on a word boundary; hence, bit 0 is read-only, returning 1 when read. See the ExCA register set description in Section 5 for register offsets.

Bit	31	30	29	28	27	26	25	24	23	22	21	20	19	18	17	16
Name	PC Card 16-bit I/F legacy-mode base-address															
Type	RW	RW	RW	RW	RW	RW	RW	RW	RW	RW	RW	RW	RW	RW	RW	RW
Default	0	0	0	0	0	0	0	0	0	0	0	0	0	0	0	0
Bit	15	14	13	12	11	10	9	8	7	6	5	4	3	2	1	0
Name	PC Card 16-bit I/F legacy-mode base-address															
Type	RW	RW	RW	RW	RW	RW	RW	RW	RW	RW	RW	RW	RW	RW	RW	R
Default	0	0	0	0	0	0	0	0	0	0	0	0	0	0	0	1

Register: **PC Card 16-bit I/F legacy-mode base-address**  
 Offset: 44h (Function 0)  
 Type: Read-only, Read/Write  
 Default: 0000 0001h

## 4.28 System Control Register

System-level initializations are performed through programming this doubleword register. Some of the bits are global in nature and must be accessed only through function 0. See Table 4–8 for a complete description of the register contents.

Bit	31	30	29	28	27	26	25	24	23	22	21	20	19	18	17	16
Name	System control															
Type	RW	RW	RW	R	R	RW	RW	RW	R	RW	RW	RW	RW	RW	RW	RW
Default	0	0	0	0	1	0	0	0	0	1	0	0	0	1	0	0
Bit	15	14	13	12	11	10	9	8	7	6	5	4	3	2	1	0
Name	System control															
Type	RW	RW	R	R	R	R	R	R	R	RW	RW	RW	RW	R	RW	RW
Default	1	0	0	1	0	0	0	0	0	1	1	0	0	0	0	0

Register: **System control**  
 Offset: 80h (Function 0)  
 Type: Read-only, Read/Write  
 Default: 0844 9060h

**Table 4–8. System Control Register Description**

BIT	SIGNAL	TYPE	FUNCTION
31–30	SER_STEP	RW	Serial input stepping. In the serial PCI interrupt mode, these bits are used to configure the serial stream PCI interrupt frames, and can be used to accomplish an even distribution of interrupts signaled on the four PCI interrupt slots. 00 = $\overline{\text{INTA}}/\overline{\text{INTB}}$ signal in $\overline{\text{INTA}}/\overline{\text{INTB}}$ slots (default) 01 = $\overline{\text{INTA}}/\overline{\text{INTB}}$ signal in $\overline{\text{INTB}}/\overline{\text{INTC}}$ slots 10 = $\overline{\text{INTA}}/\overline{\text{INTB}}$ signal in $\overline{\text{INTC}}/\overline{\text{INTD}}$ slots 11 = $\overline{\text{INTA}}/\overline{\text{INTB}}$ signal in $\overline{\text{INTD}}/\overline{\text{INTA}}$ slots
29	INTRTIE	RW	This bit ties $\overline{\text{INTA}}$ to $\overline{\text{INTB}}$ internally (to $\overline{\text{INTA}}$ ), and reports this through the interrupt pin register (PCI offset 3Dh, see Section 4.23). This bit has no effect on $\overline{\text{INTC}}$ or $\overline{\text{INTD}}$ .
28	RSVD	R	Reserved. Bit 28 returns 0 when read.
27	OSEN	R	Internal oscillator enable. The PCI4510 device hardwires this bit to 1 such that the internal oscillator is always enabled.
26	SMIROUTE	RW	SMI interrupt routing. This bit selects whether IRQ2 or CSC is signaled when a write occurs to power a PC Card socket. 0 = PC Card power change interrupts are routed to IRQ2 (default). 1 = A CSC interrupt is generated on PC Card power changes.
25	SMISTATUS	RW	SMI interrupt status. This socket-dependent bit is set when a write occurs to set the socket power, and the SMIENB bit is set. Writing a 1 to this bit clears the status. 0 = SMI interrupt is signaled. 1 = SMI interrupt is not signaled.
24	SMIENB	RW	SMI interrupt mode enable. When this bit is set, the SMI interrupt signaling generates an interrupt when a write to the socket power control occurs. This bit is shared and defaults to 0 (disabled). 0 = SMI interrupt mode is disabled (default). 1 = SMI interrupt mode is enabled.
23	RSVD	R	Reserved
22	CBRSVD	RW	CardBus reserved terminals signaling. When this bit is set and a CardBus card has been inserted, the RSVD CardBus terminals are driven low. When this bit is low, these signals are placed in a high-impedance state. 0 = Place the CardBus RSVD terminals in a high-impedance state. 1 = Drive the CardBus RSVD terminals low (default).
21	VCCPROT	RW	$V_{CC}$ protection enable. This bit is socket dependent. 0 = $V_{CC}$ protection is enabled for 16-bit cards (default). 1 = $V_{CC}$ protection is disabled for 16-bit cards.



**Table 4–8. System Control Register Description (Continued)**

BIT	SIGNAL	TYPE	FUNCTION
20	REDUCEZV	RW	Reduced zoomed video enable. When this bit is enabled, AD25–AD22 of the card interface for 16-bit PC Cards are placed in the high impedance state. This bit is encoded as: 0 = Reduced zoomed video is disabled (default). 1 = Reduced zoomed video is enabled.
19–16	RSVD	RW	Reserved. Do not change the default value.
15	MRBURSTDN	RW	Memory read burst enable downstream. When this bit is set, the PCI4510 device allows memory read transactions to burst downstream. 0 = MRBURSTDN downstream is disabled. 1 = MRBURSTDN downstream is enabled (default).
14	MRBURSTUP	RW	Memory read burst enable upstream. When this bit is set, the PCI4510 device allows memory read transactions to burst upstream. 0 = MRBURSTUP upstream is disabled (default). 1 = MRBURSTUP upstream is enabled.
13	SOACTIVE	R	Socket activity status. When set, this bit indicates access has been performed to or from a PC Card. Reading this bit causes it to be cleared. This bit is socket dependent. 0 = No socket activity (default) 1 = Socket activity
12	RSVD	R	Reserved. This bit returns 1 when read.
11	PWRSTREAM	R	Power-stream-in-progress status bit. When set, this bit indicates that a power stream to the power switch is in progress and a powering change has been requested. When this bit is cleared, it indicates that the power stream is complete. 0 = Power stream is complete, delay has expired (default). 1 = Power stream is in progress.
10	DELAYUP	R	Power-up delay-in-progress status bit. When set, this bit indicates that a power-up stream has been sent to the power switch, and proper power may not yet be stable. This bit is cleared when the power-up delay has expired. 0 = Power-up delay has expired (default). 1 = Power-up stream sent to switch. Power might not be stable.
9	DELAYDOWN	R	Power-down delay-in-progress status bit. When set, this bit indicates that a power-down stream has been sent to the power switch, and proper power may not yet be stable. This bit is cleared when the power-down delay has expired. 0 = Power-down delay has expired (default). 1 = Power-down stream sent to switch. Power might not be stable.
8	INTERROGATE	R	Interrogation in progress. When set, this bit indicates an interrogation is in progress, and clears when the interrogation completes. This bit is socket-dependent. 0 = Interrogation not in progress (default) 1 = Interrogation in progress
7	RSVD	R	Reserved. This bit returns 0 when read.
6	PWRSAVINGS	RW	Power savings mode enable. When this bit is set, the PCI4510 device consumes less power with no performance loss. This bit is shared between the two PCI4510 CardBus functions. 0 = Power savings mode disabled 1 = Power savings mode enabled (default)
5	SUBSYSRW	RW	Subsystem ID and subsystem vendor ID, ExCA ID and revision register read/write enable. This bit also controls read/write for the function 3 subsystem ID register. 0 = Registers are read/write. 1 = Registers are read-only (default).
4	CB_DPAR	RW	CardBus data parity SERR signaling enable. 0 = CardBus data parity not signaled on PCI $\overline{\text{SERR}}$ signal (default) 1 = CardBus data parity signaled on PCI SERR signal
3	RSVD	RW	Reserved. Do not change the default value.
2	RSVD	R	Reserved. This bit returns 0 when read.

**Table 4–8. System Control Register Description (Continued)**

BIT	SIGNAL	TYPE	FUNCTION
1	KEEPCLK	RW	<p>Keep clock. When this bit is set, the PCI4510 device follows the <math>\overline{\text{CLKRUN}}</math> protocol to maintain the system PCLK and the CCLK (CardBus clock). This bit is global to the PCI4510 functions.</p> <p>0 = Allow system PCLK and CCLK to stop (default)            1 = Never allow system PCLK or CCLK clock to stop</p> <p>Note that the functionality of this bit has changed relative to that of the PCI12XX family of TI CardBus controllers. In these CardBus controllers, setting this bit only maintains the PCI clock, not the CCLK. In the PCI4510 device, setting this bit maintains both the PCI clock and the CCLK.</p>
0	RIMUX	RW	<p><math>\overline{\text{PME/RI\_OUT}}</math> select bit. When this bit is 1, the PME signal is routed to the <math>\overline{\text{PME/RI\_OUT}}</math> terminal (PDV 21, GHK J03, RGVF T03). When this bit is 0 and bit 7 (RIENB) of the card control register is 1, the <math>\overline{\text{RI\_OUT}}</math> signal is routed to the <math>\overline{\text{PME/RI\_OUT}}</math> terminal. If this bit is 0 and bit 7 (RIENB) of the card control register is 0, then the output (21, J03, or T03) is placed in a high-impedance state. This terminal is encoded as:</p> <p>0 = <math>\overline{\text{RI\_OUT}}</math> signal is routed to the <math>\overline{\text{PME/RI\_OUT}}</math> terminal if bit 7 of the card control register is 1. (default)            1 = PME signal is routed to the <math>\overline{\text{PME/RI\_OUT}}</math> terminal of the PCI4510 controller.</p> <p>NOTE: If this bit (bit 0) is 0 and bit 7 of the card control register (PCI offset 91h, see Section 4.36) is 0, then the output on the <math>\overline{\text{PME/RI\_OUT}}</math> terminal is placed in a high-impedance state.</p>

**4.29 General Control Register**

The general control register provides top level PCI arbitration control. It also provides the ability to disable the 1394 OHCI function and provides control over miscellaneous new functionality. See Table 4–9 for a complete description of the register contents.

Bit	15	14	13	12	11	10	9	8	7	6	5	4	3	2	1	0
Name	General control															
Type	R	R	R	R	R	RW	R	R	R	R	R	R	RW	R	RW	RW
Default	0	0	0	0	0	0	0	0	0	0	0	0	0	0	0	0

Register: **General control**  
 Offset: 86h  
 Type: Read/Write, Read-only  
 Default: 0000h

**Table 4–9. General Control Register Description**

BIT	SIGNAL	TYPE	FUNCTION
15–11	RSVD	R	Reserved. These bits return 0s when read.
10	12V_SW_SEL	RW	<p>Power switch select. This bit selects which power switch is implemented in the system.</p> <p>0 = The TPS2221 power switch is used (default).            1 = The TPS2211A power switch is used.</p>
9–4	RSVD	R	Reserved. These bits return 0s when read.
3	DISABLE_OHCI	RW	When set, the open HCI 1394 controller function is completely nonaccessible and nonfunctional.
2	RSVD	R	Reserved. This bit returns 0 when read.
1–0	ARB_CTRL	RW	<p>Controls top level PCI arbitration</p> <p>00 = 1394 open HCI priority      10 = Fair round robin            01 = CardBus priority            11 = Fair round robin</p>

### 4.30 General-Purpose Event Status Register

The general-purpose event status register contains status bits that are set when general events occur, and can be programmed to generate general-purpose event signaling through  $\overline{\text{GPE}}$ . See Table 4–10 for a complete description of the register contents.

Bit	7	6	5	4	3	2	1	0
Name	General-purpose event status							
Type	RCU	RCU	R	RCU	RCU	RCU	RCU	RCU
Default	0	0	0	0	0	0	0	0

Register: **General-purpose event status**  
 Offset: 88h  
 Type: Read/Clear/Update, Read-only  
 Default: 00h

**Table 4–10. General-Purpose Event Status Register Description**

BIT	SIGNAL	TYPE	FUNCTION
7	PWR_STS	RCU	Power change status. This bit is set when software changes the $V_{CC}$ or $V_{PP}$ power state of either socket.
6	VPP12_STS	RCU	12-V $V_{PP}$ request status. This bit is set when software has changed the requested $V_{PP}$ level to or from 12 V for either socket.
5	RSVD	R	Reserved. This bit returns 0 when read. A write has no effect.
4	GP4_STS	RCU	GPI4 status. This bit is set on a change in status of the MFUNC5 terminal input level if configured as a general-purpose input, GPI4.
3	GP3_STS	RCU	GPI3 status. This bit is set on a change in status of the MFUNC4 terminal input level if configured as a general-purpose input, GPI3.
2	GP2_STS	RCU	GPI2 status. This bit is set on a change in status of the MFUNC2 terminal input level if configured as a general-purpose input, GPI2.
1	GP1_STS	RCU	GPI1 status. This bit is set on a change in status of the MFUNC1 terminal input level if configured as a general-purpose input, GPI1.
0	GP0_STS	RCU	GPI0 status. This bit is set on a change in status of the MFUNC0 terminal input level if configured as a general-purpose input, GPI0.

### 4.31 General-Purpose Event Enable Register

The general-purpose event enable register contains bits that are set to enable  $\overline{\text{GPE}}$  signals. See Table 4–11 for a complete description of the register contents.

Bit	7	6	5	4	3	2	1	0
Name	General-purpose event enable							
Type	RW	RW	R	RW	RW	RW	RW	RW
Default	0	0	0	0	0	0	0	0

Register: **General-purpose event enable**  
 Offset: 89h  
 Type: Read-only, Read/Write  
 Default: 00h

**Table 4–11. General-Purpose Event Enable Register Description**

BIT	SIGNAL	TYPE	FUNCTION
7	PWR_EN	RW	Power change $\overline{\text{GPE}}$ enable. When this bit is set, $\overline{\text{GPE}}$ is signaled on PWR_STS events.
6	VPP12_EN	RW	12-V $V_{PP}$ $\overline{\text{GPE}}$ enable. When this bit is set, $\overline{\text{GPE}}$ is signaled on VPP12_STS events.
5	RSVD	R	Reserved. This bit returns 0 when read. A write has no effect.
4	GP4_EN	RW	GPI4 $\overline{\text{GPE}}$ enable. When this bit is set, $\overline{\text{GPE}}$ is signaled on GP4_STS events.
3	GP3_EN	RW	GPI3 $\overline{\text{GPE}}$ enable. When this bit is set, $\overline{\text{GPE}}$ is signaled on GP3_STS events.
2	GP2_EN	RW	GPI2 $\overline{\text{GPE}}$ enable. When this bit is set, $\overline{\text{GPE}}$ is signaled on GP2_STS events.
1	GP1_EN	RW	GPI1 $\overline{\text{GPE}}$ enable. When this bit is set, $\overline{\text{GPE}}$ is signaled on GP1_STS events.
0	GP0_EN	RW	GPI0 $\overline{\text{GPE}}$ enable. When this bit is set, $\overline{\text{GPE}}$ is signaled on GP0_STS events.

### 4.32 General-Purpose Input Register

The general-purpose input register contains the logical value of the data input to the GPI terminals. See Table 4–12 for a complete description of the register contents.

Bit	7	6	5	4	3	2	1	0
Name	General-purpose input							
Type	R	R	R	RU	RU	RU	RU	RU
Default	0	0	0	X	X	X	X	X

Register: **General-purpose input**  
 Offset: 8Ah  
 Type: Read/Update, Read-only  
 Default: XXh

**Table 4–12. General-Purpose Input Register Description**

BIT	SIGNAL	TYPE	FUNCTION
7–5	RSVD	R	Reserved. These bits return 0s when read. Writes have no effect.
4	GPI4_DATA	RU	GPI4 data input. This bit represents the logical value of the data input from GPI4.
3	GPI3_DATA	RU	GPI3 data input. This bit represents the logical value of the data input from GPI3.
2	GPI2_DATA	RU	GPI2 data input. This bit represents the logical value of the data input from GPI2.
1	GPI1_DATA	RU	GPI1 data input. This bit represents the logical value of the data input from GPI1.
0	GPI0_DATA	RU	GPI0 data input. This bit represents the logical value of the data input from GPI0.

### 4.33 General-Purpose Output Register

The general-purpose output register is used to drive the GPO4–GPO0 outputs. See Table 4–13 for a complete description of the register contents.

<b>Bit</b>	<b>7</b>	<b>6</b>	<b>5</b>	<b>4</b>	<b>3</b>	<b>2</b>	<b>1</b>	<b>0</b>
<b>Name</b>	General-purpose output							
<b>Type</b>	R	R	R	RW	RW	RW	RW	RW
<b>Default</b>	0	0	0	0	0	0	0	0

Register: **General-purpose output**

Offset: 8Bh

Type: Read-only, Read/Write

Default: 00h

**Table 4–13. General-Purpose Output Register Description**

<b>BIT</b>	<b>SIGNAL</b>	<b>TYPE</b>	<b>FUNCTION</b>
7–5	RSVD	R	Reserved. These bits return 0s when read. Writes have no effect.
4	GPO4_DATA	RW	This bit represents the logical value of the data driven to GPO4.
3	GPO3_DATA	RW	This bit represents the logical value of the data driven to GPO3.
2	GPO2_DATA	RW	This bit represents the logical value of the data driven to GPO2.
1	GPO1_DATA	RW	This bit represents the logical value of the data driven to GPO1.
0	GPO0_DATA	RW	This bit represents the logical value of the data driven to GPO0.

## 4.34 Multifunction Routing Status Register

The multifunction routing status register is used to configure the MFUNC0–MFUNC6 terminals. These terminals may be configured for various functions. This register is intended to be programmed once at power-on initialization. The default value for this register can also be loaded through a serial ROM. All bits in this register are GRST only bits. See Table 4–14 for a complete description of the register contents.

Bit	31	30	29	28	27	26	25	24	23	22	21	20	19	18	17	16
Name	Multifunction routing status															
Type	R	R	R	R	RW	RW	RW	RW	RW	RW	RW	RW	RW	RW	RW	RW
Default	0	0	0	0	0	0	0	0	0	0	0	0	0	0	0	0
Bit	15	14	13	12	11	10	9	8	7	6	5	4	3	2	1	0
Name	Multifunction routing status															
Type	RW	RW	RW	RW	RW	RW	RW	RW	RW	RW	RW	RW	RW	RW	RW	RW
Default	0	0	0	1	0	0	0	0	0	0	0	0	0	0	0	0

Register: **Multifunction routing status**

Offset: 8Ch

Type: Read/Write, Read-only

Default: 0000 1000h

**Table 4–14. Multifunction Routing Status Register Description**

BIT	SIGNAL	TYPE	FUNCTION
31–28	RSVD	R	Bits 31–28 return 0s when read.
27–24	MFUNC6_SEL	RW	Multifunction terminal 6 select. This bit controls the mapping of the MFUNC6 terminal as follows: 0000 = <u>RSVD</u> 0100 = IRQ4      1000 = IRQ8      1100 = IRQ12 0001 = <u>CLKRUN</u> 0101 = IRQ5      1001 = IRQ9      1101 = IRQ13 0010 = IRQ2        0110 = IRQ6      1010 = IRQ10     1110 = IRQ14 0011 = IRQ3        0111 = IRQ7      1011 = IRQ11     1111 = IRQ15
23–20	MFUNC5_SEL	RW	Multifunction terminal 5 select. This bit controls the mapping of the MFUNC5 terminal as follows: 0000 = GPI4        0100 = IRQ4      1000 = CAUDPWM   1100 = LED_SKT 0001 = <u>GPO4</u> 0101 = IRQ5      1001 = IRQ9      1101 = LED_SKT 0010 = <u>PCGNT</u> 0110 = ZVSTAT    1010 = IRQ10     1110 = GPE 0011 = IRQ3        0111 = RSVD      1011 = OHCI_LED   1111 = IRQ15
19–16	MFUNC4_SEL	RW	Multifunction terminal 4 select. This bit controls the mapping of the MFUNC4 terminal as follows: 0000 = GPI3        0100 = IRQ4      1000 = CAUDPWM   1100 = <u>RI_OUT</u> 0001 = <u>GPO3</u> 0101 = IRQ5      1001 = IRQ9      1101 = LED_SKT 0010 = <u>LOCK</u> 0110 = ZVSTAT    1010 = RSVD      1110 = GPE 0011 = IRQ3        0111 = RSVD      1011 = IRQ11     1111 = IRQ15
15–12	MFUNC3_SEL	RW	Multifunction terminal 3 select. This bit controls the mapping of the MFUNC3 terminal as follows: 0000 = RSVD        0100 = IRQ4      1000 = IRQ8      1100 = IRQ12 0001 = IRQSER     0101 = IRQ5      1001 = IRQ9      1101 = IRQ13 0010 = IRQ2        0110 = IRQ6      1010 = IRQ10     1110 = IRQ14 0011 = IRQ3        0111 = IRQ7      1011 = IRQ11     1111 = IRQ15
11–8	MFUNC2_SEL	RW	Multifunction terminal 2 select. This bit controls the mapping of the MFUNC2 terminal as follows: 0000 = GPI2        0100 = IRQ4      1000 = CAUDPWM   1100 = <u>RI_OUT</u> 0001 = <u>GPO2</u> 0101 = IRQ5      1001 = IRQ9      1101 = TEST_MUX 0010 = <u>PCREQ</u> 0110 = <u>ZVSTAT</u> 1010 = IRQ10     1110 = GPE 0011 = IRQ3        0111 = ZVSEL0    1011 = RSVD      1111 = IRQ7

**Table 4–14. Multifunction Routing Status Register Description (Continued)**

BIT	SIGNAL	TYPE	FUNCTION
7–4	MFUNC1_SEL	RW	Multifunction terminal 1 select. This bit controls the mapping of the MFUNC1 terminal as follows: 0000 = GPI1      0100 = OHCI_LED    1000 = CAUDPWM    1100 = LED_SKT 0001 = GPO1      0101 = IRQ5        1001 = IRQ9        1101 = RSVD 0010 = INTB      0110 = ZVSTAT     1010 = IRQ10      1110 = GPE 0011 = IRQ3      0111 = ZVSELO     1011 = IRQ11      1111 = IRQ15
3–0	MFUNC0_SEL	RW	Multifunction terminal 0 select. This bit controls the mapping of the MFUNC0 terminal as follows: 0000 = GPIO0      0100 = IRQ4        1000 = CAUDPWM    1100 = LED_SKT 0001 = GPO0      0101 = IRQ5        1001 = IRQ9        1101 = RSVD 0010 = INTA      0110 = ZVSTAT     1010 = IRQ10      1110 = GPE 0011 = IRQ3      0111 = ZVSELO     1011 = IRQ11      1111 = IRQ15

### 4.35 Retry Status Register

The contents of the retry status register enable the retry time-out counters and display the retry expiration status. The flags are set when the PCI4510 device retries a PCI or CardBus master request, and the master does not return within 2<sup>15</sup> PCI clock cycles. The flags are cleared by writing a 1 to the bit. These bits are expected to be incorporated into the command register (PCI offset 04h, see Section 4.4), status register (PCI offset 06h, see Section 4.5), and bridge control register (PCI offset 3Eh, see Section 4.24) by the PCI SIG. Access this register only through function 0. See Table 4–15 for a complete description of the register contents.

Bit	7	6	5	4	3	2	1	0
Name	Retry status							
Type	RW	RW	R	R	RC	R	RC	R
Default	1	1	0	0	0	0	0	0

Register: **Retry status**  
 Offset: 90h (Function 0)  
 Type: Read-only, Read/Write, Read/Clear  
 Default: C0h

**Table 4–15. Retry Status Register Description**

BIT	SIGNAL	TYPE	FUNCTION
7	PCIRETRY	RW	PCI retry time-out counter enable. This bit is encoded as: 0 = PCI retry counter disabled 1 = PCI retry counter enabled (default)
6	CBRETRY	RW	CardBus retry time-out counter enable. This bit is encoded as: 0 = CardBus retry counter disabled 1 = CardBus retry counter enabled (default)
5–4	RSVD	R	Reserved. These bits return 0s when read.
3	TEXP_CBA	RC	CardBus target A retry expired. Write a 1 to clear this bit. 0 = Inactive (default) 1 = Retry has expired.
2	RSVD	R	Reserved. This bit returns 0 when read.
1	TEXP_PCI	RC	PCI target retry expired. Write a 1 to clear this bit. 0 = Inactive (default) 1 = Retry has expired.
0	RSVD	R	Reserved. This bit returns 0 when read.

### 4.36 Card Control Register

The card control register provides several control bits for  $\overline{\text{RI\_OUT}}$ , ZV, and other functionalities. See Table 4–16 for a complete description of the register contents.

The  $\overline{\text{RI\_OUT}}$  signal is enabled through this register.

Bit	7	6	5	4	3	2	1	0
Name	Card control							
Type	RW	RW	R	R	R	RW	RW	RW
Default	0	0	0	0	0	0	0	0

Register: **Card control**  
 Offset: 91h  
 Type: Read-only, Read/Write  
 Default: 00h

**Table 4–16. Card Control Register Description**

BIT	SIGNAL	TYPE	FUNCTION
7	RIENB	RW	Ring indicate enable. When this bit is 1, the $\overline{\text{RI\_OUT}}$ output is enabled. This bit defaults to 0.
6	ZVENABLE	RW	Compatibility ZV mode enable. When this bit is 1, the corresponding PC Card socket interface ZV terminals enter a high-impedance state. This bit defaults to 0.
5–3	RSVD	R	Reserved. These bits default to 0.
2	AUD2MUX	RW	CardBus audio-to-MFUNC. When this bit is set, the CAUDIO CardBus signal must be routed through an MFUNC terminal. If this bit is set for both functions, then function 0 is routed. 0 = CAUDIO set to CAUDPWM on MFUNC terminal (default) 1 = CAUDIO is not routed.
1	SPKROUTEN	RW	Speaker output enable. When this bit is 1, it enables $\overline{\text{SPKR}}$ on the PC Card and routes it to SPKROUT on the PCI bus. This bit is encoded as: 0 = $\overline{\text{SPKR}}$ to SPKROUT not enabled (default) 1 = $\overline{\text{SPKR}}$ to SPKROUT enabled
0	IFG	RW	Interrupt flag. This bit is the interrupt flag for 16-bit I/O PC Cards and for CardBus cards. This bit is set when a functional interrupt is signaled from a PC Card interface, and is socket dependent (that is, not global). Write back a 1 to clear this bit. 0 = No PC Card functional interrupt detected (default) 1 = PC Card functional interrupt detected



## 4.37 Device Control Register

The device control register is provided for PCI1130 compatibility. The interrupt mode select is programmed through this register. The socket-capable force bits are also programmed through this register. See Table 4–17 for a complete description of the register contents.

Bit	7	6	5	4	3	2	1	0
Name	Device control							
Type	RW	RW	RW	R	RW	RW	RW	RW
Default	0	1	1	0	0	1	1	0

Register: **Device control**  
 Offset: 92h (Function 0)  
 Type: Read-only, Read/Write  
 Default: 66h

**Table 4–17. Device Control Register Description**

BIT	SIGNAL	TYPE	FUNCTION
7	SKTPWR_LOCK	RW	Socket power lock bit. When this bit is set to 1, software cannot power down the PC Card socket while in D3. It may be necessary to lock socket power in order to support wake on LAN or RING if the operating system is programmed to power down a socket when the CardBus controller is placed in the D3 state.
6	3VCAPABLE	RW	3-V socket capable force bit. 0 = Not 3-V capable 1 = 3-V capable (default)
5	IO16R2	RW	Diagnostic bit. This bit defaults to 1.
4	RSVD	R	Reserved. This bit returns 0 when read. A write has no effect.
3	TEST	RW	TI test bit. Write only 0 to this bit. This bit can be set to shorten the interrogation counter.
2–1	INTMODE	RW	Interrupt mode. These bits select the interrupt signaling mode. The interrupt mode bits are encoded: 00 = Parallel PCI interrupts only 01 = Parallel IRQ and parallel PCI interrupts 10 = IRQ serialized interrupts and parallel PCI interrupts $\overline{INTA}$ and $\overline{INTB}$ 11 = IRQ and PCI serialized interrupts (default)
0	RSVD	RW	Reserved. NAND tree enable bit. There is a NAND tree diagnostic structure in the PCI4510 device, and it tests only the terminals that are inputs or I/Os. Any output-only terminal on the PCI4510 device is excluded from the NAND tree test.

### 4.38 Diagnostic Register

The diagnostic register is provided for internal TI test purposes. It is a read/write register, but only 0s must be written to it. See Table 4–18 for a complete description of the register contents.

Bit	7	6	5	4	3	2	1	0
Name	Diagnostic							
Type	RW	R	RW	RW	RW	RW	RW	RW
Default	0	1	1	0	0	0	0	0

Register: **Diagnostic**  
 Offset: 93h (Function 0)  
 Type: Read/Write  
 Default: 60h

**Table 4–18. Diagnostic Register Description**

BIT	SIGNAL	TYPE	FUNCTION
7	TRUE_VAL	RW	This bit defaults to 0. This bit is encoded as: 0 = Reads true values in PCI vendor ID and PCI device ID registers (default) 1 = Reads all 1s in reads to the PCI vendor ID and PCI device ID registers
6	RSVD	R	Reserved. This bit is read-only and returns 1 when read.
5	CSC	RW	CSC interrupt routing control 0 = CSC interrupts routed to PCI if ExCA 803 bit 4 = 1 1 = CSC interrupts routed to PCI if ExCA 805 bits 7–4 = 0000b (default). In this case, the setting of ExCA 803 bit 4 is a don't care.
4	DIAG4	RW	Diagnostic RETRY_DIS. Delayed transaction disable.
3	DIAG3	RW	Diagnostic RETRY_EXT. Extends the latency from 16 to 64.
2	DIAG2	RW	Diagnostic DISCARD_TIM_SEL_CB. Set = 2 <sup>10</sup> , reset = 2 <sup>15</sup> .
1	DIAG1	RW	Diagnostic DISCARD_TIM_SEL_PCI. Set = 2 <sup>10</sup> , reset = 2 <sup>15</sup> .
0	ZV_EN	RW	Zoomed video enable. 0 = Enable new ZV register model (default) 1 = Disable new ZV register mode

### 4.39 Capability ID Register

The capability ID register identifies the linked list item as the register for PCI power management. The register returns 01h when read, which is the unique ID assigned by the PCI SIG for the PCI location of the capabilities pointer and the value.

Bit	7	6	5	4	3	2	1	0
Name	Capability ID							
Type	R	R	R	R	R	R	R	R
Default	0	0	0	0	0	0	0	1

Register: **Capability ID**  
Offset: A0h  
Type: Read-only  
Default: 01h

### 4.40 Next Item Pointer Register

The contents of this register indicate the next item in the linked list of the PCI power management capabilities. Because the PCI4510 function only includes one capability item, this register returns 0s when read.

Bit	7	6	5	4	3	2	1	0
Name	Next item pointer							
Type	R	R	R	R	R	R	R	R
Default	0	0	0	0	0	0	0	0

Register: **Next item pointer**  
Offset: A1h  
Type: Read-only  
Default: 00h

## 4.41 Power Management Capabilities Register

The power management capabilities register contains information on the capabilities of the PC Card function related to power management. Both PCI4510 CardBus bridge functions support D0, D1, D2, and D3 power states. Default register value is FE12h for operation in accordance with *PCI Bus Power Management Interface Specification* revision 1.1. See Table 4–19 for a complete description of the register contents.

Bit	15	14	13	12	11	10	9	8	7	6	5	4	3	2	1	0
Name	Power management capabilities															
Type	RW	R	R	R	R	R	R	R	R	R	R	R	R	R	R	R
Default	1	1	1	1	1	1	1	0	0	0	1	1	0	0	1	0

Register: **Power management capabilities**  
 Offset: A2h (Function 0)  
 Type: Read-only, Read/Write  
 Default: FE32h

**Table 4–19. Power Management Capabilities Register Description**

BIT	SIGNAL	TYPE	FUNCTION
15	PME support	RW	This 5-bit field indicates the power states from which the PCI4510 device functions can assert $\overline{\text{PME}}$ . A 0 for any bit indicates that the function cannot assert the $\overline{\text{PME}}$ signal while in that power state. These 5 bits return 0Fh when read. Each of these bits is described below:  Bit 15 – defaults to a 1 indicating the $\overline{\text{PME}}$ signal can be asserted from the D3 <sub>cold</sub> state. This bit is read/write because wake-up support from D3 <sub>cold</sub> is contingent on the system providing an auxiliary power source to the V <sub>CC</sub> terminals. If the system designer chooses not to provide an auxiliary power source to the V <sub>CC</sub> terminals for D3 <sub>cold</sub> wake-up support, then BIOS must write a 0 to this bit.
14–11		R	Bit 14 – contains the value 1 to indicate that the $\overline{\text{PME}}$ signal can be asserted from the D3 <sub>hot</sub> state. Bit 13 – contains the value 1 to indicate that the $\overline{\text{PME}}$ signal can be asserted from the D2 state. Bit 12 – contains the value 1 to indicate that the $\overline{\text{PME}}$ signal can be asserted from the D1 state. Bit 11 – contains the value 1 to indicate that the $\overline{\text{PME}}$ signal can be asserted from the D0 state.
10		R	This bit returns a 1 when read, indicating that the function supports the D2 device power state.
9		R	This bit returns a 1 when read, indicating that the function supports the D1 device power state.
8–6		RSVD	R
5	DSI	R	Device-specific initialization. This bit returns 0 when read.
4	AUX_PWR	R	Auxiliary power source. This bit is meaningful only if bit 15 (D3 <sub>cold</sub> supporting $\overline{\text{PME}}$ ) is set. When this bit is set, it indicates that support for $\overline{\text{PME}}$ in D3 <sub>cold</sub> requires auxiliary power supplied by the system by way of a proprietary delivery vehicle.  A 0 (zero) in this bit field indicates that the function supplies its own auxiliary power source.  If the function does not support PME while in the D3 <sub>cold</sub> state (bit 15=0), then this field must always return 0.
3	PMECLK	R	When this bit is 1, it indicates that the function relies on the presence of the PCI clock for $\overline{\text{PME}}$ operation. When this bit is 0, it indicates that no PCI clock is required for the function to generate $\overline{\text{PME}}$ .  Functions that do not support PME generation in any state must return 0 for this field.
2–0	Version	R	These 3 bits return 010b when read, indicating that there are 4 bytes of general-purpose power management (PM) registers as described in draft revision 1.1 of the <i>PCI Bus Power Management Interface Specification</i> .

## 4.42 Power Management Control/Status Register

The power management control/status register determines and changes the current power state of the PCI4510 CardBus function. The contents of this register are not affected by the internally generated reset caused by the transition from the D3<sub>hot</sub> to D0 state. See Table 4–20 for a complete description of the register contents.

All PCI registers, ExCA registers, and CardBus registers are reset as a result of a D3<sub>hot</sub>-to-D0 state transition, with the exception of the  $\overline{\text{PME}}$  context bits (if  $\overline{\text{PME}}$  is enabled) and the  $\overline{\text{GRST}}$  only bits.

Bit	15	14	13	12	11	10	9	8	7	6	5	4	3	2	1	0
Name	Power management control/status															
Type	RWC	R	R	R	R	R	R	RW	R	R	R	R	R	R	RW	RW
Default	0	0	0	0	0	0	0	0	0	0	0	0	0	0	0	0

Register: **Power management control/status**  
 Offset: A4h (Function 0)  
 Type: Read-only, Read/Write, Read/Write/Clear  
 Default: 0000h

**Table 4–20. Power Management Control/Status Register Description**

BIT	SIGNAL	TYPE	FUNCTION
15	PMESTAT	RC	PME status. This bit is set when the CardBus function would normally assert the $\overline{\text{PME}}$ signal, independent of the state of the $\overline{\text{PME\_EN}}$ bit. This bit is cleared by a writeback of 1, and this also clears the $\overline{\text{PME}}$ signal if $\overline{\text{PME}}$ was asserted by this function. Writing a 0 to this bit has no effect.
14–13	DATASCALE	R	This 2-bit field returns 0s when read. The CardBus function does not return any dynamic data.
12–9	DATASEL	R	Data select. This 4-bit field returns 0s when read. The CardBus function does not return any dynamic data.
8	PME_ENABLE	RW	This bit enables the function to assert $\overline{\text{PME}}$ . If this bit is cleared, then assertion of $\overline{\text{PME}}$ is disabled. This bit is not cleared by the assertion of $\overline{\text{PRST}}$ . It is only cleared by the assertion of $\overline{\text{GRST}}$ .
7–2	RSVD	R	Reserved. These bits return 0s when read.
1–0	PWRSTATE	RW	Power state. This 2-bit field is used both to determine the current power state of a function and to set the function into a new power state. This field is encoded as: 00 = D0 01 = D1 10 = D2 11 = D3 <sub>hot</sub>

### 4.43 Power Management Control/Status Bridge Support Extensions Register

This register supports PCI bridge-specific functionality. It is required for all PCI-to-PCI bridges. See Table 4–21 for a complete description of the register contents.

Bit	7	6	5	4	3	2	1	0
Name	Power management control/status bridge support extensions							
Type	R	R	R	R	R	R	R	R
Default	1	1	0	0	0	0	0	0

Register: **Power management control/status bridge support extensions**  
 Offset: A6h (Function 0)  
 Type: Read-only  
 Default: C0h

**Table 4–21. Power Management Control/Status Bridge Support Extensions Register Description**

BIT	SIGNAL	TYPE	FUNCTION
7	BPCC_EN	R	Bus power/clock control enable. This bit returns 1 when read. This bit is encoded as: 0 = Bus power/clock control is disabled. 1 = Bus power/clock control is enabled (default).  A 0 indicates that the bus power/clock control policies defined in the <i>PCI Bus Power Management Interface Specification</i> are disabled. When the bus power/clock control enable mechanism is disabled, the power state field (bits 1–0) of the bridge power management control/status register (PCI offset A4h, see Section 4.42) cannot be used by the system software to control the power or the clock of the bridge secondary bus. A 1 indicates that the bus power/clock control mechanism is enabled.
6	<u>B2_B3</u>	R	B2/B3 support for D3 <sub>hot</sub> . The state of this bit determines the action that is to occur as a direct result of programming the function to D3 <sub>hot</sub> . This bit is only meaningful if bit 7 (BPCC_EN) is a 1. This bit is encoded as: 0 = When the bridge is programmed to D3 <sub>hot</sub> , its secondary bus has its power removed (B3). 1 = When the bridge function is programmed to D3 <sub>hot</sub> , its secondary bus PCI clock is stopped (B2) (default).
5–0	RSVD	R	Reserved. These bits return 0s when read.

### 4.44 Serial Bus Data Register

The serial bus data register is for programmable serial bus byte reads and writes. This register represents the data when generating cycles on the serial bus interface. To write a byte, this register must be programmed with the data, the serial bus index register must be programmed with the byte address, the serial bus slave address must be programmed with both the 7-bit slave address, and the read/write indicator bit must be reset.

On byte reads, the byte address is programmed into the serial bus index register, the serial bus slave address register must be programmed with both the 7-bit slave address and the read/write indicator bit, and bit 5 (REQBUSY) in the serial bus control and status register (see Section 4.47) must be polled until clear. Then the contents of this register are valid read data from the serial bus interface. See Table 4–22 for a complete description of the register contents.

Bit	7	6	5	4	3	2	1	0
Name	Serial bus data							
Type	RW	RW	RW	RW	RW	RW	RW	RW
Default	0	0	0	0	0	0	0	0

Register: **Serial bus data**  
 Offset: B0h (Function 0)  
 Type: Read/Write  
 Default: 00h

**Table 4–22. Serial Bus Data Register Description**

BIT	SIGNAL	TYPE	FUNCTION
7–0	SBDATA	RW	Serial bus data. This bit field represents the data byte in a read or write transaction on the serial interface. On reads, the REQBUSY bit must be polled to verify that the contents of this register are valid.

## 4.45 Serial Bus Index Register

The serial bus index register is for programmable serial bus byte reads and writes. This register represents the byte address when generating cycles on the serial bus interface. To write a byte, the serial bus data register must be programmed with the data, this register must be programmed with the byte address, and the serial bus slave address must be programmed with both the 7-bit slave address and the read/write indicator.

On byte reads, the word address is programmed into this register, the serial bus slave address must be programmed with both the 7-bit slave address and the read/write indicator bit, and bit 5 (REQBUSY) in the serial bus control and status register (see Section 4.47) must be polled until clear. Then the contents of the serial bus data register are valid read data from the serial bus interface. See Table 4–23 for a complete description of the register contents.

Bit	7	6	5	4	3	2	1	0
Name	Serial bus index							
Type	RW	RW	RW	RW	RW	RW	RW	RW
Default	0	0	0	0	0	0	0	0

Register: **Serial bus index**  
 Offset: B1h (Function 0)  
 Type: Read/Write  
 Default: 00h

**Table 4–23. Serial Bus Index Register Description**

BIT	SIGNAL	TYPE	FUNCTION
7–0	SBINDEX	RW	Serial bus index. This bit field represents the byte address in a read or write transaction on the serial interface.

## 4.46 Serial Bus Slave Address Register

The serial bus slave address register is for programmable serial bus byte read and write transactions. To write a byte, the serial bus data register must be programmed with the data, the serial bus index register must be programmed with the byte address, and this register must be programmed with both the 7-bit slave address and the read/write indicator bit.

On byte reads, the byte address is programmed into the serial bus index register, this register must be programmed with both the 7-bit slave address and the read/write indicator bit, and bit 5 (REQBUSY) in the serial bus control and status register (see Section 4.47) must be polled until clear. Then the contents of the serial bus data register are valid read data from the serial bus interface. See Table 4–24 for a complete description of the register contents.

Bit	7	6	5	4	3	2	1	0
Name	Serial bus slave address							
Type	RW	RW	RW	RW	RW	RW	RW	RW
Default	0	0	0	0	0	0	0	0

Register: **Serial bus slave address**  
 Offset: B2h (Function 0)  
 Type: Read/Write  
 Default: 00h

**Table 4–24. Serial Bus Slave Address Register Description**

BIT	SIGNAL	TYPE	FUNCTION
7–1	SLAVADDR	RW	Serial bus slave address. This bit field represents the slave address of a read or write transaction on the serial interface.
0	RWCMD	RW	Read/write command. Bit 0 indicates the read/write command bit presented to the serial bus on byte read and write accesses. 0 = A byte write access is requested to the serial bus interface. 1 = A byte read access is requested to the serial bus interface.

## 4.47 Serial Bus Control and Status Register

The serial bus control and status register communicates serial bus status information and selects the quick command protocol. Bit 5 (REQBUSY) in this register must be polled during serial bus byte reads to indicate when data is valid in the serial bus data register. See Table 4–25 for a complete description of the register contents.

Bit	7	6	5	4	3	2	1	0
Name	Serial bus control and status							
Type	RW	R	R	R	RW	RW	RC	RC
Default	0	0	0	0	0	0	0	0

Register: **Serial bus control and status**  
 Offset: B3h (Function 0)  
 Type: Read-only, Read/Write, Read/Clear  
 Default: 00h

**Table 4–25. Serial Bus Control and Status Register Description**

BIT	SIGNAL	TYPE	FUNCTION
7	PROT_SEL	RW	Protocol select. When bit 7 is set, the send-byte protocol is used on write requests and the receive-byte protocol is used on read commands. The word address byte in the serial bus index register (see Section 4.45) is not output by the PCI4510 device when bit 7 is set.
6	RSVD	R	Reserved. Bit 6 returns 0 when read.
5	REQBUSY	R	Requested serial bus access busy. Bit 5 indicates that a requested serial bus access (byte read or write) is in progress. A request is made, and bit 5 is set, by writing to the serial bus slave address register (see Section 4.46). Bit 5 must be polled on reads from the serial interface. After the byte read access has been requested, the read data is valid in the serial bus data register.
4	ROMBUSY	R	Serial ROM busy status. Bit 4 indicates the status of the PCI4510 serial ROM circuitry. Bit 4 is set during the loading of the subsystem ID and other default values from the serial bus ROM. 0 = Serial ROM circuitry is not busy 1 = Serial ROM circuitry is busy
3	SBDETECT	RW	Serial bus detect. When bit 3 is set, it indicates that the serial bus interface is detected through a pullup resistor on the SCL terminal after reset. 0 = Serial bus interface not detected 1 = Serial bus interface detected
2	SBTEST	RW	Serial bus test. When bit 2 is set, the serial bus clock frequency is increased for test purposes. 0 = Serial bus clock at normal operating frequency, ≈ 100 kHz (default) 1 = Serial bus clock frequency increased for test purposes
1	REQ_ERR	RC	Requested serial bus access error. Bit 1 indicates when a data error occurs on the serial interface during a requested cycle and may be set due to a missing acknowledge. Bit 1 is cleared by a writeback of 1. 0 = No error detected during user requested byte read or write cycle 1 = Data error detected during user requested byte read or write cycle
0	ROM_ERR	RC	ROM data error status. Bit 0 indicates when a data error occurs on the serial interface during the auto-load from the serial bus ROM and may be set due to a missing acknowledge. Bit 0 is also set on invalid ROM data formats. See Section 3.6.3, <i>Serial Bus EEPROM Application</i> , for details on ROM data format. Bit 0 is cleared by a writeback of 1. 0 = No error detected during auto-load from serial bus ROM 1 = Data error detected during auto-load from serial bus ROM



## 5 ExCA Compatibility Registers (Function 0)

The ExCA registers implemented in the PCI4510 device are register-compatible with the Intel 82365SL-DF PCMCIA controller. ExCA registers are identified by an offset value that is compatible with the legacy I/O index/data scheme used on the Intel 82365 ISA controller. The ExCA registers are accessed through this scheme by writing the register offset value into the index register (I/O base) and reading or writing the data register (I/O base + 1). The I/O base address used in the index/data scheme is programmed in the PC Card 16-bit I/F legacy-mode base address register (PCI offset 44h, see Section 4.27), which is shared by both card sockets. The offsets from this base address run contiguously from 00h to 3Fh for the socket. See Figure 5-1 for an ExCA I/O mapping illustration.

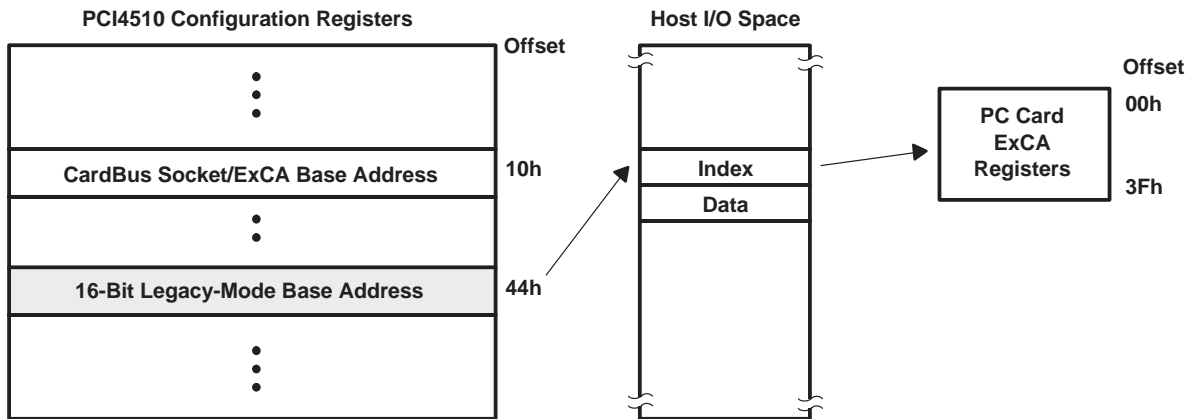

Figure 5-1. ExCA Register Access Through I/O

The TI PCI4510 device also provides a memory-mapped alias of the ExCA registers by directly mapping them into PCI memory space. They are located through the CardBus socket register/ExCA base-address register (PCI offset 10h, see Section 4.11) at memory offset 800h. Each socket has a separate base address programmable by function. See Figure 5-2 for an ExCA memory mapping illustration. Note that memory offsets are 800h-844h for function 0. This illustration also identifies the CardBus socket register mapping, which is mapped into the same 4-K window at memory offset 00h.

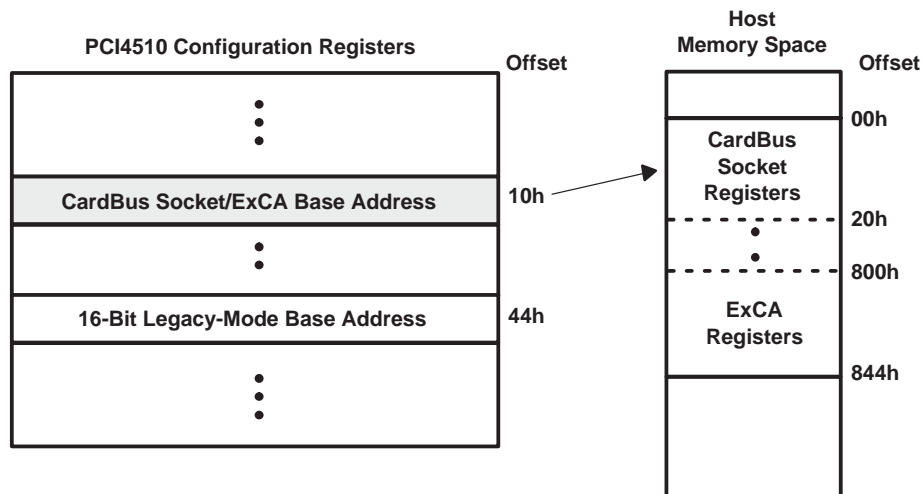

Figure 5-2. ExCA Register Access Through Memory

The interrupt registers in the ExCA register set, as defined by the 82365SL–DL specification, control such card functions as reset, type, interrupt routing, and interrupt enables. Special attention must be paid to the interrupt routing registers and the host interrupt signaling method selected for the PCI4510 device to ensure that all possible PCI4510 interrupts can potentially be routed to the programmable interrupt controller. The ExCA registers that are critical to the interrupt signaling are the ExCA interrupt and general control register (ExCA offset 03h/803h, see Section 5.4) and the ExCA card status-change interrupt configuration register (ExCA offset 05h/805h, see Section 5.6).

Access to I/O-mapped 16-bit PC cards is available to the host system via two ExCA I/O windows. These are regions of host I/O address space into which the card I/O space is mapped. These windows are defined by start, end, and offset addresses programmed in the ExCA registers described in this section. I/O windows have byte granularity.

Access to memory-mapped 16-bit PC Cards is available to the host system via five ExCA memory windows. These are regions of host memory space into which the card memory space is mapped. These windows are defined by start, end, and offset addresses programmed in the ExCA registers described in this section. Table 5–1 identifies each ExCA register and its respective ExCA offset. Memory windows have 4-Kbyte granularity.

**Table 5–1. ExCA Registers and Offsets**

ExCA REGISTER NAME	PCI MEMORY ADDRESS OFFSET (HEX)	ExCA OFFSET (HEX)
Identification and revision	800	00
Interface status	801	01
Power control	802	02
Interrupt and general control	803	03
Card status change	804	04
Card status-change interrupt configuration	805	05
Address window enable	806	06
I / O window control	807	07
I / O window 0 start-address low byte	808	08
I / O window 0 start-address high byte	809	09
I / O window 0 end-address low byte	80A	0A
I / O window 0 end-address high byte	80B	0B
I / O window 1 start-address low byte	80C	0C
I / O window 1 start-address high byte	80D	0D
I / O window 1 end-address low byte	80E	0E
I / O window 1 end-address high byte	80F	0F
Memory window 0 start-address low byte	810	10
Memory window 0 start-address high byte	811	11
Memory window 0 end-address low byte	812	12
Memory window 0 end-address high byte	813	13
Memory window 0 offset-address low byte	814	14
Memory window 0 offset-address high byte	815	15
Card detect and general control	816	16
Reserved	817	17
Memory window 1 start-address low byte	818	18
Memory window 1 start-address high byte	819	19
Memory window 1 end-address low byte	81A	1A
Memory window 1 end-address high byte	81B	1B
Memory window 1 offset-address low byte	81C	1C
Memory window 1 offset-address high byte	81D	1D

**Table 5–1. ExCA Registers and Offsets (Continued)**

ExCA REGISTER NAME	PCI MEMORY ADDRESS OFFSET (HEX)	ExCA OFFSET (HEX)
Global control	81E	1E
Reserved	81F	1F
Memory window 2 start-address low byte	820	20
Memory window 2 start-address high byte	821	21
Memory window 2 end-address low byte	822	22
Memory window 2 end-address high byte	823	23
Memory window 2 offset-address low byte	824	24
Memory window 2 offset-address high byte	825	25
Reserved	826	26
Reserved	827	27
Memory window 3 start-address low byte	828	28
Memory window 3 start-address high byte	829	29
Memory window 3 end-address low byte	82A	2A
Memory window 3 end-address high byte	82B	2B
Memory window 3 offset-address low byte	82C	2C
Memory window 3 offset-address high byte	82D	2D
Reserved	82E	2E
Reserved	82F	2F
Memory window 4 start-address low byte	830	30
Memory window 4 start-address high byte	831	31
Memory window 4 end-address low byte	832	32
Memory window 4 end-address high byte	833	33
Memory window 4 offset-address low byte	834	34
Memory window 4 offset-address high byte	835	35
I/O window 0 offset-address low byte	836	36
I/O window 0 offset-address high byte	837	37
I/O window 1 offset-address low byte	838	38
I/O window 1 offset-address high byte	839	39
Reserved	83A	3A
Reserved	83B	3B
Reserved	83C	3C
Reserved	83D	3D
Reserved	83E	3E
Reserved	83F	3F
Memory window page 0	840	–
Memory window page 1	841	–
Memory window page 2	842	–
Memory window page 3	843	–
Memory window page 4	844	–

A bit description table, typically included when a register contains bits of more than one type or purpose, indicates bit field names, which appear in the signal column; a detailed field description, which appears in the function column; and field access tags, which appear in the type column of the bit description table. Table 4–1 describes the field access tags.

## 5.1 ExCA Identification and Revision Register

The ExCA identification and revision register provides host software with information on 16-bit PC Card support and Intel 82365SL-DF compatibility. This register is read-only or read/write, depending on the setting of bit 5 (SUBSYSRW) in the system control register (PCI offset 80h, see Section 4.28). See Table 5–2 for a complete description of the register contents.

Bit	7	6	5	4	3	2	1	0
Name	ExCA identification and revision							
Type	R	R	RW	RW	RW	RW	RW	RW
Default	1	0	0	0	0	1	0	0

Register: **ExCA identification and revision**  
 Offset: CardBus socket address + 800h; ExCA offset 00h  
 Type: Read-only, Read/Write  
 Default: 84h

**Table 5–2. ExCA Identification and Revision Register Description**

BIT	SIGNAL	TYPE	FUNCTION
7–6	IFTYPE	R	Interface type. These bits, which are hardwired as 10b, identify the 16-bit PC Card support provided by the PCI4510 device. The PCI4510 device supports both I/O and memory 16-bit PC cards.
5–4	RSVD	RW	Reserved. Bits 5 and 4 can be used for Intel 82365SL-DF emulation.
3–0	365REV	RW	Intel 82365SL-DF revision. This field stores the Intel 82365SL-DF revision supported by the PCI4510 device. Host software can read this field to determine compatibility to the Intel 82365SL-DF register set. Writing 0010b to this field puts the controller in 82365SL mode.

## 5.2 ExCA Interface Status Register

The ExCA interface status register provides information on the current status of the PC Card interface. An X in the default bit value indicates that the value of the bit after reset depends on the state of the PC Card interface. See Table 5–3 for a complete description of the register contents.

Bit	7	6	5	4	3	2	1	0
Name	ExCA interface status							
Type	R	R	R	R	R	R	R	R
Default	0	0	X	X	X	X	X	X

Register: **ExCA interface status**  
 Offset: CardBus socket address + 801h; ExCA offset 01h  
 Type: Read-only  
 Default: 00XX XXXXb

**Table 5–3. ExCA Interface Status Register Description**

BIT	SIGNAL	TYPE	FUNCTION
7	RSVD	R	Reserved. Bit 7 returns 0 when read.
6	CARDPWR	R	Card power. Bit 6 indicates the current power status of the PC Card socket. This bit reflects how the ExCA power control register (ExCA offset 02h/802h, see Section 5.3) is programmed. Bit 6 is encoded as: 0 = $V_{CC}$ and $V_{PP}$ to the socket turned off (default) 1 = $V_{CC}$ and $V_{PP}$ to the socket turned on
5	READY	R	Ready. Bit 5 indicates the current status of the READY signal at the PC Card interface. 0 = PC Card not ready for data transfer 1 = PC Card ready for data transfer
4	CARDWP	R	Card write protect (WP). Bit 4 indicates the current status of the WP signal at the PC Card interface. This signal reports to the PCI4510 device whether or not the memory card is write protected. Furthermore, write protection for an entire PCI4510 16-bit memory window is available by setting the appropriate bit in the memory window offset-address high-byte register. 0 = WP is 0. PC Card is read/write. 1 = WP is 1. PC Card is read-only.
3	CDETECT2	R	Card detect 2. Bit 3 indicates the status of the $\overline{CD2}$ signal at the PC Card interface. Software may use this and bit 2 (CDETECT1) to determine if a PC Card is fully seated in the socket. 0 = $\overline{CD2}$ is 1. No PC Card is inserted. 1 = $\overline{CD2}$ is 0. PC Card is at least partially inserted.
2	CDETECT1	R	Card detect 1. Bit 2 indicates the status of the $\overline{CD1}$ signal at the PC Card interface. Software may use this and bit 3 (CDETECT2) to determine if a PC Card is fully seated in the socket. 0 = $\overline{CD1}$ is 1. No PC Card is inserted. 1 = $\overline{CD1}$ is 0. PC Card is at least partially inserted.
1–0	BVDSTAT	R	Battery voltage detect. When a 16-bit memory card is inserted, the field indicates the status of the battery voltage detect signals (BVD1, BVD2) at the PC Card interface, where bit 1 reflects the BVD2 status and bit 0 reflects BVD1. 00 = Battery dead 01 = Battery dead 10 = Battery low; warning 11 = Battery good  When a 16-bit I/O card is inserted, this field indicates the status of $\overline{SPKR}$ (bit 1) and $\overline{STSCHG}$ (bit 0) at the PC Card interface. In this case, the two bits in this field directly reflect the current state of these card outputs.

### 5.3 ExCA Power Control Register

The ExCA power control register provides PC Card power control. Bit 7 (COE) of this register controls the 16-bit output enables on the socket interface, and can be used for power management in 16-bit PC Card applications. See Table 5–4 and Table 5–5 for a complete description of the register contents.

Bit	7	6	5	4	3	2	1	0
Name	ExCA power control							
Type	RW	R	R	RW	RW	R	RW	RW
Default	0	0	0	0	0	0	0	0

Register: **ExCA power control**  
 Offset: CardBus socket address + 802h; ExCA offset 02h  
 Type: Read-only, Read/Write  
 Default: 00h

**Table 5–4. ExCA Power Control Register Description—82365SL Support**

BIT	SIGNAL	TYPE	FUNCTION
7	COE	RW	Card output enable. Bit 7 controls the state of all of the 16-bit outputs on the PCI4510 device. This bit is encoded as: 0 = 16-bit PC Card outputs disabled (default) 1 = 16-bit PC Card outputs enabled
6	RSVD	R	Reserved. Bit 6 returns 0 when read.
5	AUTOPWRSWEN	RW	Auto power switch enable. 0 = Automatic socket power switching based on card detects is disabled. 1 = Automatic socket power switching based on card detects is enabled.
4	CAPWREN	RW	PC Card power enable. 0 = V <sub>CC</sub> = No connection 1 = V <sub>CC</sub> is enabled and controlled by bit 2 (EXCAPOWER) of the system control register (PCI offset 80h, see Section 4.28).
3–2	RSVD	R	Reserved. Bits 3 and 2 return 0s when read.
1–0	EXCAVPP	RW	PC Card V <sub>pp</sub> power control. Bits 1 and 0 are used to request changes to card V <sub>pp</sub> . The PCI4510 device ignores this field unless V <sub>CC</sub> to the socket is enabled. This field is encoded as: 00 = No connection (default) 01 = V <sub>CC</sub> 10 = 12 V 11 = Reserved

**Table 5–5. ExCA Power Control Register Description—82365SL-DF Support**

BIT	SIGNAL	TYPE	FUNCTION
7	COE	RW	Card output enable. Bit 7 controls the state of all of the 16-bit outputs on the PCI4510 device. This bit is encoded as: 0 = 16-bit PC Card outputs disabled (default) 1 = 16-bit PC Card outputs enabled
6–5	RSVD	R	Reserved. Bits 6 and 5 return 0s when read.
4–3	EXCAVCC	RW	V <sub>CC</sub> . Bits 4 and 3 are used to request changes to card V <sub>CC</sub> . This field is encoded as: 00 = 0 V (default) 01 = 0 V reserved 10 = 5 V 11 = 3.3 V
2	RSVD	R	Reserved. Bit 2 returns 0 when read.
1–0	EXCAVPP	RW	V <sub>pp</sub> . Bits 1 and 0 are used to request changes to card V <sub>pp</sub> . The PCI4510 device ignores this field unless V <sub>CC</sub> to the socket is enabled. This field is encoded as: 00 = No connection (default) 01 = V <sub>CC</sub> 10 = 12 V 11 = Reserved

## 5.4 ExCA Interrupt and General Control Register

The ExCA interrupt and general control register controls interrupt routing for I/O interrupts, as well as other critical 16-bit PC Card functions. See Table 5–6 for a complete description of the register contents.

Bit	7	6	5	4	3	2	1	0
Name	ExCA interrupt and general control							
Type	RW	RW	RW	RW	RW	RW	RW	RW
Default	0	0	0	0	0	0	0	0

Register: **ExCA interrupt and general control**  
 Offset: CardBus socket address + 803h; ExCA offset 03h  
 Type: Read/Write  
 Default: 00h

**Table 5–6. ExCA Interrupt and General Control Register Description**

BIT	SIGNAL	TYPE	FUNCTION
7	RINGEN	RW	Card ring indicate enable. Bit 7 enables the ring indicate function of the BVD1/ $\overline{RI}$ signal. This bit is encoded as: 0 = Ring indicate disabled (default) 1 = Ring indicate enabled
6	RESET	RW	Card reset. Bit 6 controls the 16-bit PC Card RESET signal, and allows host software to force a card reset. Bit 6 affects 16-bit cards only. This bit is encoded as: 0 = RESET signal asserted (default) 1 = RESET signal deasserted
5	CARDTYPE	RW	Card type. Bit 5 indicates the PC card type. This bit is encoded as: 0 = Memory PC Card installed (default) 1 = I/O PC Card installed
4	CSCROUTE	RW	PCI interrupt CSC routing enable bit. When bit 4 is set (high), the card status change interrupts are routed to PCI interrupts. When low, the card status change interrupts are routed using bits 7–4 (CSCSELECT field) in the ExCA card status-change interrupt configuration register (ExCA offset 05h/805h, see Section 5.6). This bit is encoded as: 0 = CSC interrupts are routed by ExCA registers (default). 1 = CSC interrupts are routed to PCI interrupts.
3–0	INTSELECT	RW	Card interrupt select for I/O PC Card functional interrupts. Bits 3–0 select the interrupt routing for I/O PC Card functional interrupts. This field is encoded as: 0000 = No interrupt routing (default). Functional interrupts are routed to PCI interrupts. This bit setting is ORed with bit 4 (CSCROUTE) for backward compatibility. 0001 = IRQ1 enabled 0010 = SMI enabled 0011 = IRQ3 enabled 0100 = IRQ4 enabled 0101 = IRQ5 enabled 0100 = IRQ6 enabled 0111 = IRQ7 enabled 1000 = IRQ8 enabled 1001 = IRQ9 enabled 1010 = IRQ10 enabled 1011 = IRQ11 enabled 1100 = IRQ12 enabled 1101 = IRQ13 enabled 1110 = IRQ14 enabled 1111 = IRQ15 enabled

## 5.5 ExCA Card Status-Change Register

The ExCA card status-change register controls interrupt routing for I/O interrupts as well as other critical 16-bit PC Card functions. The register enables these interrupt sources to generate an interrupt to the host. When the interrupt source is disabled, the corresponding bit in this register always reads 0. When an interrupt source is enabled, the corresponding bit in this register is set to indicate that the interrupt source is active. After generating the interrupt to the host, the interrupt service routine must read this register to determine the source of the interrupt. The interrupt service routine is responsible for resetting the bits in this register as well. Resetting a bit is accomplished by one of two methods: a read of this register or an explicit write back of 1 to the status bit. The choice of these two methods is based on bit 2 (interrupt flag clear mode select) in the ExCA global control register (ExCA offset 1E/81E, see Section 5.20). See Table 5–7 for a complete description of the register contents.

Bit	7	6	5	4	3	2	1	0
Name	ExCA card status-change							
Type	R	R	R	R	R	R	R	R
Default	0	0	0	0	0	0	0	0

Register: **ExCA card status-change**  
 Offset: CardBus socket address + 804h; ExCA offset 04h  
 Type: Read-only  
 Default: 00h

**Table 5–7. ExCA Card Status-Change Register Description**

BIT	SIGNAL	TYPE	FUNCTION
7–4	RSVD	R	Reserved. Bits 7–4 return 0s when read.
3	CDCHANGE	R	Card detect change. Bit 3 indicates whether a change on the $\overline{CD1}$ or $\overline{CD2}$ signal occurred at the PC Card interface. This bit is encoded as: 0 = No change detected on either $\overline{CD1}$ or $\overline{CD2}$ signal 1 = Change detected on either $\overline{CD1}$ or $\overline{CD2}$ signal
2	READYCHANGE	R	Ready change. When a 16-bit memory is installed in the signal socket, bit 2 includes whether the source of a PCI4510 interrupt was due to a change on the READY signal at the PC Card interface, indicating that the PC Card is now ready to accept new data. This bit is encoded as: 0 = No low-to-high transition detected on the READY signal (default) 1 = Detected low-to-high transition on the READY signal  When a 16-bit I/O card is installed, bit 2 is always 0.
1	BATWARN	R	Battery warning change. When a 16-bit memory card is installed in the socket, bit 1 indicates whether the source of a PCI4510 interrupt was due to a battery-low warning condition. This bit is encoded as: 0 = No battery warning condition (default) 1 = Detected battery warning condition  When a 16-bit I/O card is installed, bit 1 is always 0.
0	BATDEAD	R	Battery dead or status change. When a 16-bit memory card is installed in the socket, bit 0 indicates whether the source of a PCI4510 interrupt was due to a battery dead condition. This bit is encoded as: 0 = $\overline{STSCHG}$ signal deasserted (default) 1 = $\overline{STSCHG}$ signal asserted  Ring indicate. When the PCI4510 device is configured for ring indicate operation, bit 0 indicates the status of the RI signal.



## 5.6 ExCA Card Status-Change Interrupt Configuration Register

The ExCA card status-change interrupt configuration register controls interrupt routing for card status-change interrupts, as well as masking CSC interrupt sources. See Table 5–8 for a complete description of the register contents.

Bit	7	6	5	4	3	2	1	0
Name	ExCA status-change-interrupt configuration							
Type	RW	RW	RW	RW	RW	RW	RW	RW
Default	0	0	0	0	0	0	0	0

Register: **ExCA card status-change interrupt configuration**  
 Offset: CardBus socket address + 805h; ExCA offset 05h  
 Type: Read/Write  
 Default: 00h

**Table 5–8. ExCA Card Status-Change Interrupt Configuration Register Description**

BIT	SIGNAL	TYPE	FUNCTION																
7–4	CSCSELECT	RW	<p>Interrupt select for card status change. Bits 7–4 select the interrupt routing for card status-change interrupts.</p> <p>0000 = CSC interrupts are routed to PCI interrupts if bit 5 (CSC) of the diagnostic register (PCI offset 93h, see Section 4.38) is set to 1. In this case bit 4 (CSCROUTE) of the ExCA interrupt and general control register (ExCA offset 03h/803h, see Section 5.4) is a don't care. This is the default setting.</p> <p>0000 = No ISA interrupt routing if bit 5 (CSC) of the diagnostic register is set to 0 (see Section 4.38). In this case, CSC interrupts are routed to PCI interrupts by setting bit 4 (CSCROUTE) of the ExCA interrupt and general control register (ExCA offset 03h/803h, see Section 5.4) to 1.</p> <p>This field is encoded as:</p> <table style="width: 100%; border: none;"> <tr> <td style="width: 50%;">0000 = No interrupt routing (default)</td> <td style="width: 50%;">1000 = IRQ8 enabled</td> </tr> <tr> <td>0001 = IRQ1 enabled</td> <td>1001 = IRQ9 enabled</td> </tr> <tr> <td>0010 = SMI enabled</td> <td>1010 = IRQ10 enabled</td> </tr> <tr> <td>0011 = IRQ3 enabled</td> <td>1011 = IRQ11 enabled</td> </tr> <tr> <td>0100 = IRQ4 enabled</td> <td>1100 = IRQ12 enabled</td> </tr> <tr> <td>0101 = IRQ5 enabled</td> <td>1101 = IRQ13 enabled</td> </tr> <tr> <td>0110 = IRQ6 enabled</td> <td>1110 = IRQ14 enabled</td> </tr> <tr> <td>0111 = IRQ7 enabled</td> <td>1111 = IRQ15 enabled</td> </tr> </table>	0000 = No interrupt routing (default)	1000 = IRQ8 enabled	0001 = IRQ1 enabled	1001 = IRQ9 enabled	0010 = SMI enabled	1010 = IRQ10 enabled	0011 = IRQ3 enabled	1011 = IRQ11 enabled	0100 = IRQ4 enabled	1100 = IRQ12 enabled	0101 = IRQ5 enabled	1101 = IRQ13 enabled	0110 = IRQ6 enabled	1110 = IRQ14 enabled	0111 = IRQ7 enabled	1111 = IRQ15 enabled
0000 = No interrupt routing (default)	1000 = IRQ8 enabled																		
0001 = IRQ1 enabled	1001 = IRQ9 enabled																		
0010 = SMI enabled	1010 = IRQ10 enabled																		
0011 = IRQ3 enabled	1011 = IRQ11 enabled																		
0100 = IRQ4 enabled	1100 = IRQ12 enabled																		
0101 = IRQ5 enabled	1101 = IRQ13 enabled																		
0110 = IRQ6 enabled	1110 = IRQ14 enabled																		
0111 = IRQ7 enabled	1111 = IRQ15 enabled																		
3	CDEN	RW	<p>Card detect enable. Bit 3 enables interrupts on <math>\overline{CD1}</math> or <math>\overline{CD2}</math> changes. This bit is encoded as:</p> <p>0 = Disables interrupts on <math>\overline{CD1}</math> or <math>\overline{CD2}</math> line changes (default)</p> <p>1 = Enables interrupts on <math>\overline{CD1}</math> or <math>\overline{CD2}</math> line changes</p>																
2	READYEN	RW	<p>Ready enable. Bit 2 enables/disables a low-to-high transition on the PC Card READY signal to generate a host interrupt. This interrupt source is considered a card status change. This bit is encoded as:</p> <p>0 = Disables host interrupt generation (default)</p> <p>1 = Enables host interrupt generation</p>																
1	BATWARNEN	RW	<p>Battery warning enable. Bit 1 enables/disables a battery warning condition to generate a CSC interrupt. This bit is encoded as:</p> <p>0 = Disables host interrupt generation (default)</p> <p>1 = Enables host interrupt generation</p>																
0	BATDEADEN	RW	<p>Battery dead enable. Bit 0 enables/disables a battery dead condition on a memory PC Card or assertion of the STSCHG I/O PC Card signal to generate a CSC interrupt.</p> <p>0 = Disables host interrupt generation (default)</p> <p>1 = Enables host interrupt generation</p>																

## 5.7 ExCA Address Window Enable Register

The ExCA address window enable register enables/disables the memory and I/O windows to the 16-bit PC Card. By default, all windows to the card are disabled. The PCI4510 device does not acknowledge PCI memory or I/O cycles to the card if the corresponding enable bit in this register is 0, regardless of the programming of the memory or I/O window start/end/offset address registers. See Table 5–9 for a complete description of the register contents.

Bit	7	6	5	4	3	2	1	0
Name	ExCA address window enable							
Type	RW	RW	R	RW	RW	RW	RW	RW
Default	0	0	0	0	0	0	0	0

Register: **ExCA address window enable**  
 Offset: CardBus socket address + 806h; ExCA offset 06h  
 Type: Read-only, Read/Write  
 Default: 00h

**Table 5–9. ExCA Address Window Enable Register Description**

BIT	SIGNAL	TYPE	FUNCTION
7	IOWIN1EN	RW	I/O window 1 enable. Bit 7 enables/disables I/O window 1 for the PC Card. This bit is encoded as: 0 = I/O window 1 disabled (default) 1 = I/O window 1 enabled
6	IOWIN0EN	RW	I/O window 0 enable. Bit 6 enables/disables I/O window 0 for the PC Card. This bit is encoded as: 0 = I/O window 0 disabled (default) 1 = I/O window 0 enabled
5	RSVD	R	Reserved. Bit 5 returns 0 when read.
4	MEMWIN4EN	RW	Memory window 4 enable. Bit 4 enables/disables memory window 4 for the PC Card. This bit is encoded as: 0 = Memory window 4 disabled (default) 1 = Memory window 4 enabled
3	MEMWIN3EN	RW	Memory window 3 enable. Bit 3 enables/disables memory window 3 for the PC Card. This bit is encoded as: 0 = Memory window 3 disabled (default) 1 = Memory window 3 enabled
2	MEMWIN2EN	RW	Memory window 2 enable. Bit 2 enables/disables memory window 2 for the PC Card. This bit is encoded as: 0 = Memory window 2 disabled (default) 1 = Memory window 2 enabled
1	MEMWIN1EN	RW	Memory window 1 enable. Bit 1 enables/disables memory window 1 for the PC Card. This bit is encoded as: 0 = Memory window 1 disabled (default) 1 = Memory window 1 enabled
0	MEMWIN0EN	RW	Memory window 0 enable. Bit 0 enables/disables memory window 0 for the PC Card. This bit is encoded as: 0 = Memory window 0 disabled (default) 1 = Memory window 0 enabled

## 5.8 ExCA I/O Window Control Register

The ExCA I/O window control register contains parameters related to I/O window sizing and cycle timing. See Table 5–10 for a complete description of the register contents.

Bit	7	6	5	4	3	2	1	0
Name	ExCA I/O window control							
Type	RW	RW	RW	RW	RW	RW	RW	RW
Default	0	0	0	0	0	0	0	0

Register: **ExCA I/O window control**  
 Offset: CardBus socket address + 807h; ExCA offset 07h  
 Type: Read/Write  
 Default: 00h

**Table 5–10. ExCA I/O Window Control Register Description**

BIT	SIGNAL	TYPE	FUNCTION
7	WAITSTATE1	RW	I/O window 1 wait state. Bit 7 controls the I/O window 1 wait state for 16-bit I/O accesses. Bit 7 has no effect on 8-bit accesses. This wait-state timing emulates the ISA wait state used by the Intel 82365SL-DF. This bit is encoded as: 0 = 16-bit cycles have standard length (default). 1 = 16-bit cycles are extended by one equivalent ISA wait state.
6	ZEROWS1	RW	I/O window 1 zero wait state. Bit 6 controls the I/O window 1 wait state for 8-bit I/O accesses. Bit 6 has no effect on 16-bit accesses. This wait-state timing emulates the ISA wait state used by the Intel 82365SL-DF. This bit is encoded as: 0 = 8-bit cycles have standard length (default). 1 = 8-bit cycles are reduced to equivalent of three ISA cycles.
5	IOIS16W1	RW	I/O window 1 $\overline{\text{IOIS16}}$ source. Bit 5 controls the I/O window 1 automatic data sizing feature that uses the $\overline{\text{IOIS16}}$ signal from the PC Card to determine the data width of the I/O data transfer. This bit is encoded as: 0 = Window data width is determined by bit 4 (DATASIZE1) (default). 1 = Window data width is determined by the $\overline{\text{IOIS16}}$ signal.
4	DATASIZE1	RW	I/O window 1 data size. Bit 4 controls the I/O window 1 data size. Bit 4 is ignored if bit 5 (IOIS16W1) is set. This bit is encoded as: 0 = Window data width is 8 bits (default). 1 = Window data width is 16 bits.
3	WAITSTATE0	RW	I/O window 0 wait state. Bit 3 controls the I/O window 0 wait state for 16-bit I/O accesses. Bit 3 has no effect on 8-bit accesses. This wait-state timing emulates the ISA wait state used by the Intel 82365SL-DF. This bit is encoded as: 0 = 16-bit cycles have standard length (default). 1 = 16-bit cycles are extended by one equivalent ISA wait state.
2	ZEROWS0	RW	I/O window 0 zero wait state. Bit 2 controls the I/O window 0 wait state for 8-bit I/O accesses. Bit 2 has no effect on 16-bit accesses. This wait-state timing emulates the ISA wait state used by the Intel 82365SL-DF. This bit is encoded as: 0 = 8-bit cycles have standard length (default). 1 = 8-bit cycles are reduced to equivalent of three ISA cycles.
1	IOIS16W0	RW	I/O window 0 $\overline{\text{IOIS16}}$ source. Bit 1 controls the I/O window 0 automatic data sizing feature that uses the $\overline{\text{IOIS16}}$ signal from the PC Card to determine the data width of the I/O data transfer. This bit is encoded as: 0 = Window data width is determined by bit 0 (DATASIZE0) (default). 1 = Window data width is determined by the $\overline{\text{IOIS16}}$ signal.
0	DATASIZE0	RW	I/O window 0 data size. Bit 0 controls the I/O window 0 data size. Bit 0 is ignored if bit 1 (IOIS16W0) is set. This bit is encoded as: 0 = Window data width is 8 bits (default). 1 = Window data width is 16 bits.

## 5.9 ExCA I/O Windows 0 and 1 Start-Address Low-Byte Registers

These registers contain the low byte of the 16-bit I/O window start address for I/O windows 0 and 1. The 8 bits of these registers correspond to the lower 8 bits of the start address.

Bit	7	6	5	4	3	2	1	0
Name	ExCA I/O windows 0 and 1 start-address low-byte							
Type	RW	RW	RW	RW	RW	RW	RW	RW
Default	0	0	0	0	0	0	0	0

Register: **ExCA I/O window 0 start-address low-byte**  
 Offset: CardBus socket address + 808h; ExCA offset 08h  
 Register: **ExCA I/O window 1 start-address low-byte**  
 Offset: CardBus socket address + 80Ch; ExCA offset 0Ch  
 Type: Read/Write  
 Default: 00h

## 5.10 ExCA I/O Windows 0 and 1 Start-Address High-Byte Registers

These registers contain the high byte of the 16-bit I/O window start address for I/O windows 0 and 1. The 8 bits of these registers correspond to the upper 8 bits of the end address.

Bit	7	6	5	4	3	2	1	0
Name	ExCA I/O windows 0 and 1 start-address high-byte							
Type	RW	RW	RW	RW	RW	RW	RW	RW
Default	0	0	0	0	0	0	0	0

Register: **ExCA I/O window 0 start-address high-byte**  
 Offset: CardBus socket address + 809h; ExCA offset 09h  
 Register: **ExCA I/O window 1 start-address high-byte**  
 Offset: CardBus socket address + 80Dh; ExCA offset 0Dh  
 Type: Read/write  
 Default: 00h

## 5.11 ExCA I/O Windows 0 and 1 End-Address Low-Byte Registers

These registers contain the low byte of the 16-bit I/O window end address for I/O windows 0 and 1. The 8 bits of these registers correspond to the lower 8 bits of the end address.

Bit	7	6	5	4	3	2	1	0
Name	ExCA I/O windows 0 and 1 end-address low-byte							
Type	RW	RW	RW	RW	RW	RW	RW	RW
Default	0	0	0	0	0	0	0	0

Register: **ExCA I/O window 0 end-address low-byte**  
 Offset: CardBus socket address + 80Ah; ExCA offset 0Ah  
 Register: **ExCA I/O window 1 end-address low-byte**  
 Offset: CardBus socket address + 80Eh; ExCA offset 0Eh  
 Type: Read/Write  
 Default: 00h

## 5.12 ExCA I/O Windows 0 and 1 End-Address High-Byte Registers

These registers contain the high byte of the 16-bit I/O window end address for I/O windows 0 and 1. The 8 bits of these registers correspond to the upper 8 bits of the end address.

Bit	7	6	5	4	3	2	1	0
<b>Name</b>	ExCA I/O windows 0 and 1 end-address high-byte							
<b>Type</b>	RW	RW	RW	RW	RW	RW	RW	RW
<b>Default</b>	0	0	0	0	0	0	0	0

Register: **ExCA I/O window 0 end-address high-byte**  
 Offset: CardBus socket address + 80Bh; ExCA offset 0Bh  
 Register: **ExCA I/O window 1 end-address high-byte**  
 Offset: CardBus socket address + 80Fh; ExCA offset 0Fh  
 Type: Read/write  
 Default: 00h

## 5.13 ExCA Memory Windows 0–4 Start-Address Low-Byte Registers

These registers contain the low byte of the 16-bit memory window start address for memory windows 0, 1, 2, 3, and 4. The 8 bits of these registers correspond to bits A19–A12 of the start address.

Bit	7	6	5	4	3	2	1	0
<b>Name</b>	ExCA memory windows 0–4 start-address low-byte							
<b>Type</b>	RW	RW	RW	RW	RW	RW	RW	RW
<b>Default</b>	0	0	0	0	0	0	0	0

Register: **ExCA memory window 0 start-address low-byte**  
 Offset: CardBus socket address + 810h; ExCA offset 10h  
 Register: **ExCA memory window 1 start-address low-byte**  
 Offset: CardBus socket address + 818h; ExCA offset 18h  
 Register: **ExCA memory window 2 start-address low-byte**  
 Offset: CardBus socket address + 820h; ExCA offset 20h  
 Register: **ExCA memory window 3 start-address low-byte**  
 Offset: CardBus socket address + 828h; ExCA offset 28h  
 Register: **ExCA memory window 4 start-address low-byte**  
 Offset: CardBus socket address + 830h; ExCA offset 30h  
 Type: Read/Write  
 Default: 00h

## 5.14 ExCA Memory Windows 0–4 Start-Address High-Byte Registers

These registers contain the high nibble of the 16-bit memory window start address for memory windows 0, 1, 2, 3, and 4. The lower 4 bits of these registers correspond to bits A23–A20 of the start address. In addition, the memory window data width and wait states are set in this register. See Table 5–11 for a complete description of the register contents.

Bit	7	6	5	4	3	2	1	0
Name	ExCA memory windows 0–4 start-address high-byte							
Type	RW	RW	RW	RW	RW	RW	RW	RW
Default	0	0	0	0	0	0	0	0

Register: **ExCA memory window 0 start-address high-byte**  
 Offset: CardBus socket address + 811h; ExCA offset 11h  
 Register: **ExCA memory window 1 start-address high-byte**  
 Offset: CardBus socket address + 819h; ExCA offset 19h  
 Register: **ExCA memory window 2 start-address high-byte**  
 Offset: CardBus socket address + 821h; ExCA offset 21h  
 Register: **ExCA memory window 3 start-address high-byte**  
 Offset: CardBus socket address + 829h; ExCA offset 29h  
 Register: **ExCA memory window 4 start-address high-byte**  
 Offset: CardBus socket address + 831h; ExCA offset 31h  
 Type: Read/Write  
 Default: 00h

**Table 5–11. ExCA Memory Windows 0–4 Start-Address High-Byte Registers Description**

BIT	SIGNAL	TYPE	FUNCTION
7	DATASIZE	RW	Data size. Bit 7 controls the memory window data width. This bit is encoded as: 0 = Window data width is 8 bits (default). 1 = Window data width is 16 bits.
6	ZEROWAIT	RW	Zero wait state. Bit 6 controls the memory window wait state for 8- and 16-bit accesses. This wait-state timing emulates the ISA wait state used by the Intel 82365SL-DF. This bit is encoded as: 0 = 8- and 16-bit cycles have standard length (default). 1 = 8-bit cycles are reduced to equivalent of three ISA cycles. 16-bit cycles are reduced to equivalent of two ISA cycles.
5–4	SCRATCH	RW	Scratch pad bits. Bits 5 and 4 have no effect on memory window operation.
3–0	STAHN	RW	Start-address high nibble. Bits 3–0 represent the upper address bits A23–A20 of the memory window start address.

## 5.15 ExCA Memory Windows 0–4 End-Address Low-Byte Registers

These registers contain the low byte of the 16-bit memory window end address for memory windows 0, 1, 2, 3, and 4. The 8 bits of these registers correspond to bits A19–A12 of the end address.

Bit	7	6	5	4	3	2	1	0
Name	ExCA memory windows 0–4 end-address low-byte							
Type	RW	RW	RW	RW	RW	RW	RW	RW
Default	0	0	0	0	0	0	0	0

Register: **ExCA memory window 0 end-address low-byte**  
 Offset: CardBus socket address + 812h; ExCA offset 12h  
 Register: **ExCA memory window 1 end-address low-byte**  
 Offset: CardBus socket address + 81Ah; ExCA offset 1Ah  
 Register: **ExCA memory window 2 end-address low-byte**  
 Offset: CardBus socket address + 822h; ExCA offset 22h  
 Register: **ExCA memory window 3 end-address low-byte**  
 Offset: CardBus socket address + 82Ah; ExCA offset 2Ah  
 Register: **ExCA memory window 4 end-address low-byte**  
 Offset: CardBus socket address + 832h; ExCA offset 32h  
 Type: Read/Write  
 Default: 00h

## 5.16 ExCA Memory Windows 0–4 End-Address High-Byte Registers

These registers contain the high nibble of the 16-bit memory window end address for memory windows 0, 1, 2, 3, and 4. The lower 4 bits of these registers correspond to bits A23–A20 of the end address. In addition, the memory window wait states are set in this register. See Table 5–12 for a complete description of the register contents.

Bit	7	6	5	4	3	2	1	0
Name	ExCA memory windows 0–4 end-address high-byte							
Type	RW	RW	R	R	RW	RW	RW	RW
Default	0	0	0	0	0	0	0	0

Register: **ExCA memory window 0 end-address high-byte**  
 Offset: CardBus socket address + 813h; ExCA offset 13h  
 Register: **ExCA memory window 1 end-address high-byte**  
 Offset: CardBus socket address + 81Bh; ExCA offset 1Bh  
 Register: **ExCA memory window 2 end-address high-byte**  
 Offset: CardBus socket address + 823h; ExCA offset 23h  
 Register: **ExCA memory window 3 end-address high-byte**  
 Offset: CardBus socket address + 82Bh; ExCA offset 2Bh  
 Register: **ExCA memory window 4 end-address high-byte**  
 Offset: CardBus socket address + 833h; ExCA offset 33h  
 Type: Read-only, Read/Write  
 Default: 00h

**Table 5–12. ExCA Memory Windows 0–4 End-Address High-Byte Registers Description**

BIT	SIGNAL	TYPE	FUNCTION
7–6	MEMWS	RW	Wait state. Bits 7 and 6 specify the number of equivalent ISA wait states to be added to 16-bit memory accesses. The number of wait states added is equal to the binary value of these two bits.
5–4	RSVD	R	Reserved. Bits 5 and 4 return 0s when read.
3–0	ENDHN	RW	End-address high nibble. Bits 3–0 represent the upper address bits A23–A20 of the memory window end address.

## 5.17 ExCA Memory Windows 0–4 Offset-Address Low-Byte Registers

These registers contain the low byte of the 16-bit memory window offset address for memory windows 0, 1, 2, 3, and 4. The 8 bits of these registers correspond to bits A19–A12 of the offset address.

Bit	7	6	5	4	3	2	1	0
Name	ExCA memory windows 0–4 offset-address low-byte							
Type	RW	RW	RW	RW	RW	RW	RW	RW
Default	0	0	0	0	0	0	0	0

Register: **ExCA memory window 0 offset-address low-byte**  
 Offset: CardBus socket address + 814h; ExCA offset 14h  
 Register: **ExCA memory window 1 offset-address low-byte**  
 Offset: CardBus socket address + 81Ch; ExCA offset 1Ch  
 Register: **ExCA memory window 2 offset-address low-byte**  
 Offset: CardBus socket address + 824h; ExCA offset 24h  
 Register: **ExCA memory window 3 offset-address low-byte**  
 Offset: CardBus socket address + 82Ch; ExCA offset 2Ch  
 Register: **ExCA memory window 4 offset-address low-byte**  
 Offset: CardBus socket address + 834h; ExCA offset 34h  
 Type: Read/Write  
 Default: 00h



## 5.18 ExCA Memory Windows 0–4 Offset-Address High-Byte Registers

These registers contain the high 6 bits of the 16-bit memory window offset address for memory windows 0, 1, 2, 3, and 4. The lower 6 bits of these registers correspond to bits A25–A20 of the offset address. In addition, the write protection and common/attribute memory configurations are set in this register. See Table 5–13 for a complete description of the register contents.

Bit	7	6	5	4	3	2	1	0
Name	ExCA memory windows 0–4 offset-address high-byte							
Type	RW	RW	RW	RW	RW	RW	RW	RW
Default	0	0	0	0	0	0	0	0

Register: **ExCA memory window 0 offset-address high-byte**

Offset: CardBus socket address + 815h; ExCA offset 15h

Register: **ExCA memory window 1 offset-address high-byte**

Offset: CardBus socket address + 81Dh; ExCA offset 1Dh

Register: **ExCA memory window 2 offset-address high-byte**

Offset: CardBus socket address + 825h; ExCA offset 25h

Register: **ExCA memory window 3 offset-address high-byte**

Offset: CardBus socket address + 82Dh; ExCA offset 2Dh

Register: **ExCA memory window 4 offset-address high-byte**

Offset: CardBus socket address + 835h; ExCA offset 35h

Type: Read/Write

Default: 00h

**Table 5–13. ExCA Memory Windows 0–4 Offset-Address High-Byte Registers Description**

BIT	SIGNAL	TYPE	FUNCTION
7	WINWP	RW	Write protect. Bit 7 specifies whether write operations to this memory window are enabled. This bit is encoded as: 0 = Write operations are allowed (default). 1 = Write operations are not allowed.
6	REG	RW	Bit 6 specifies whether this memory window is mapped to card attribute or common memory. This bit is encoded as: 0 = Memory window is mapped to common memory (default). 1 = Memory window is mapped to attribute memory.
5–0	OFFHB	RW	Offset-address high byte. Bits 5–0 represent the upper address bits A25–A20 of the memory window offset address.

## 5.19 ExCA Card Detect and General Control Register

The ExCA card detect and general control register controls how the ExCA registers for the socket respond to card removal, as well as reports the status of the  $\overline{VS1}$  and  $\overline{VS2}$  signals at the PC Card interface. See Table 5–14 for a complete description of the register contents.

Bit	7	6	5	4	3	2	1	0
Name	ExCA I/O card detect and general control							
Type	R	R	RW	RW	R	R	RW	R
Default	X	X	0	0	0	0	0	0

Register: **ExCA card detect and general control**  
 Offset: CardBus socket address + 816h; ExCA offset 16h  
 Type: Read-only, Read/Write  
 Default: XX00 0000b

**Table 5–14. ExCA Card Detect and General Control Register Description**

BIT	SIGNAL	TYPE	FUNCTION
7	VS2STAT	R	$\overline{VS2}$ state. Bit 7 reports the current state of the $\overline{VS2}$ signal at the PC Card interface and, therefore, does not have a default value. 0 = $\overline{VS2}$ is low 1 = $\overline{VS2}$ is high
6	VS1STAT	R	$\overline{VS1}$ state. Bit 6 reports the current state of the $\overline{VS1}$ signal at the PC Card interface and, therefore, does not have a default value. 0 = $\overline{VS1}$ is low 1 = $\overline{VS1}$ is high
5	SWCSC	RW	Software card detect interrupt. If bit 3 (CDEN) in the ExCA card status-change interrupt configuration register (ExCA offset 05h/805, see Section 5.6) is set, then writing a 1 to bit 5 causes a card-detect card-status change interrupt for the associated card socket. If bit 3 (CDEN) in the ExCA card status-change-interrupt configuration register (ExCA offset 05h/805, see Section 5.6) is cleared to 0, then writing a 1 to bit 5 has no effect. A read operation of this bit always returns 0.
4	CDRESUME	RW	Card detect resume enable. If bit 4 is set to 1, then once a card detect change has been detected on $\overline{CD1}$ and $\overline{CD2}$ inputs, the $\overline{RI\_OUT}$ signal goes from high to low. The $\overline{RI\_OUT}$ signal remains low until bit 0 (card status change) in the ExCA card status-change register is cleared (see Section 5.5). If this bit is a 0, then the card detect resume functionality is disabled. 0 = Card detect resume disabled (default) 1 = Card detect resume enabled
3–2	RSVD	R	Reserved. Bits 3 and 2 return 0s when read.
1	REGCONFIG	RW	Register configuration on card removal. Bit 1 controls how the ExCA registers for the socket react to a card removal event. This bit is encoded as: 0 = No change to ExCA registers on card removal (default) 1 = Reset ExCA registers on card removal
0	RSVD	R	Reserved. Bit 0 returns 0 when read.

## 5.20 ExCA Global Control Register

The ExCA global control register controls both PC Card sockets and is not duplicated for each socket. The host interrupt mode bits in this register are retained for Intel 82365SL-DF compatibility. See Table 5–15 for a complete description of the register contents.

Bit	7	6	5	4	3	2	1	0
Name	ExCA global control							
Type	R	R	R	R	RW	RW	RW	RW
Default	0	0	0	0	0	0	0	0

Register: **ExCA global control**  
 Offset: CardBus socket address + 81Eh; ExCA offset 1Eh  
 Type: Read-only, Read/Write  
 Default: 00h

**Table 5–15. ExCA Global Control Register Description**

BIT	SIGNAL	TYPE	FUNCTION
7–4	RSVD	R	Reserved. Bits 7–5 return 0s when read.
3	INTMODEA	RW	Level/edge interrupt mode select. Bit 3 selects the signaling mode for the PCI4510 host interrupt for card interrupts. This bit is encoded as: 0 = Host interrupt is edge mode (default). 1 = Host interrupt is level mode.
2	IFCMODE	RW	Interrupt flag clear mode select. Bit 2 selects the interrupt flag clear mechanism for the flags in the ExCA card status change register (ExCA offset 04h/804h, see Section 5.5). This bit is encoded as: 0 = Interrupt flags are cleared by read of CSC register (default). 1 = Interrupt flags are cleared by explicit writeback of 1.
1	CSCMODE	RW	Card status change level/edge mode select. Bit 1 selects the signaling mode for the PCI4510 host interrupt for card status changes. This bit is encoded as: 0 = Host interrupt is edge mode (default). 1 = Host interrupt is level mode.
0	PWRDWN	RW	Power-down mode select. When bit 0 is set to 1, the PCI4510 device is in power-down mode. In power-down mode, the PCI4510 card outputs are high-impedance until an active cycle is executed on the card interface. Following an active cycle, the outputs are again high-impedance. The PCI4510 device still receives functional interrupts and/or card status-change interrupts; however, an actual card access is required to wake up the interface. This bit is encoded as: 0 = Power-down mode is disabled (default). 1 = Power-down mode is enabled.

## 5.21 ExCA I/O Windows 0 and 1 Offset-Address Low-Byte Registers

These registers contain the low byte of the 16-bit I/O window offset address for I/O windows 0 and 1. The 8 bits of these registers correspond to the lower 8 bits of the offset address, and bit 0 is always 0.

Bit	7	6	5	4	3	2	1	0
Name	ExCA I/O windows 0 and 1 offset-address low-byte							
Type	RW	RW	RW	RW	RW	RW	RW	R
Default	0	0	0	0	0	0	0	0

Register: **ExCA I/O window 0 offset-address low-byte**  
 Offset: CardBus socket address + 836h; ExCA offset 36h  
 Register: **ExCA I/O window 1 offset-address low-byte**  
 Offset: CardBus socket address + 838h; ExCA offset 38h  
 Type: Read-only, Read/Write  
 Default: 00h

## 5.22 ExCA I/O Windows 0 and 1 Offset-Address High-Byte Registers

These registers contain the high byte of the 16-bit I/O window offset address for I/O windows 0 and 1. The 8 bits of these registers correspond to the upper 8 bits of the offset address.

Bit	7	6	5	4	3	2	1	0
Name	ExCA I/O windows 0 and 1 offset-address high-byte							
Type	RW	RW	RW	RW	RW	RW	RW	RW
Default	0	0	0	0	0	0	0	0

Register: **ExCA I/O window 0 offset-address high-byte**  
 Offset: CardBus socket address + 837h; ExCA offset 37h  
 Register: **ExCA I/O window 1 offset-address high-byte**  
 Offset: CardBus socket address + 839h; ExCA offset 39h  
 Type: Read/Write  
 Default: 00h

## 5.23 ExCA Memory Windows 0–4 Page Registers

The upper 8 bits of a 4-byte PCI memory address are compared to the contents of this register when decoding addresses for 16-bit memory windows. Each window has its own page register, all of which default to 00h. By programming this register to a nonzero value, host software can locate 16-bit memory windows in any 1 of 256 16-Mbyte regions in the 4-Gbyte PCI address space. These registers are only accessible when the ExCA registers are memory-mapped; that is, these registers cannot be accessed using the index/data I/O scheme.

Bit	7	6	5	4	3	2	1	0
Name	ExCA memory windows 0–4 page							
Type	RW	RW	RW	RW	RW	RW	RW	RW
Default	0	0	0	0	0	0	0	0

Register: **ExCA memory windows 0–4 page**  
 Offset: CardBus socket address + 840h, 841h, 842h, 843h, 844h  
 Type: Read-only, Read/Write, Read/Clear  
 Default: 00h

## 6 CardBus Socket Registers (Function 0)

The *1997 PC Card Standard* requires a CardBus socket controller to provide five 32-bit registers that report and control socket-specific functions. The PCI4510 device provides the CardBus socket/ExCA base address register (offset 10h, see Section 4.11) to locate these CardBus socket registers in PCI memory address space (see Figure 6–1). Table 6–1 gives the location of the socket registers in relation to the CardBus socket/ExCA base address.

The PCI4510 device implements an additional register at offset 20h that provides power management control for the socket.

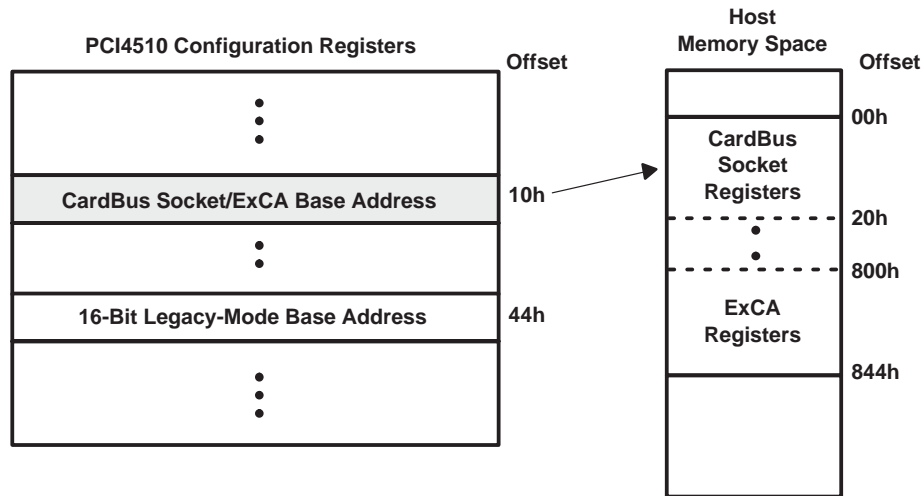

Figure 6–1. Accessing CardBus Socket Registers Through PCI Memory

Table 6–1. CardBus Socket Registers

REGISTER NAME	OFFSET
Socket event	00h
Socket mask	04h
Socket present state	08h
Socket force event	0Ch
Socket control	10h
Reserved	14h–1Ch
Socket power management	20h

## 6.1 Socket Event Register

This register indicates a change in socket status has occurred. These bits do not indicate what the change is, only that one has occurred. Software must read the socket present state register (see Section 6.3) for current status. Each bit in this register can be cleared by writing a 1 to that bit. The bits in this register can be set to a 1 by software through writing a 1 to the corresponding bit in the socket force event register (see Section 6.4). All bits in this register are cleared by PCI reset. They can be immediately set again, if, when coming out of PC Card reset, the bridge finds the status unchanged (that is, CSTSCHG reasserted or card detect is still true). Software needs to clear this register before enabling interrupts. If it is not cleared and interrupts are enabled, then an unmasked interrupt is generated based on any bit that is set. See Table 6–2 for a complete description of the register contents.

Bit	31	30	29	28	27	26	25	24	23	22	21	20	19	18	17	16
Name	Socket event															
Type	R	R	R	R	R	R	R	R	R	R	R	R	R	R	R	R
Default	0	0	0	0	0	0	0	0	0	0	0	0	0	0	0	0
Bit	15	14	13	12	11	10	9	8	7	6	5	4	3	2	1	0
Name	Socket event															
Type	R	R	R	R	R	R	R	R	R	R	R	R	RWC	RWC	RWC	RWC
Default	0	0	0	0	0	0	0	0	0	0	0	0	0	0	0	0

Register: **Socket event**  
 Offset: CardBus Socket Address + 00h  
 Type: Read-only, Read/Write to Clear  
 Default: 0000 0000h

**Table 6–2. Socket Event Register Description**

BIT	SIGNAL	TYPE	FUNCTION
31–4	RSVD	R	These bits return 0s when read.
3	PWREVENT	RWC	Power cycle. This bit is set when the PCI4510 device detects that bit 3 (PWRCYCLE) in the socket present state register (offset 08h, see Section 6.3) has changed. This bit is cleared by writing a 1.
2	CD2EVENT	RWC	$\overline{\text{CCD2}}$ . This bit is set when the PCI4510 device detects that bit 2 (CDETECT2) in the socket present state register (offset 08h, see Section 6.3) has changed. This bit is cleared by writing a 1.
1	CD1EVENT	RWC	$\overline{\text{CCD1}}$ . This bit is set when the PCI4510 device detects that bit 1 (CDETECT1) in the socket present state register (offset 08h, see Section 6.3) has changed. This bit is cleared by writing a 1.
0	CSTSEVENT	RWC	CSTSCHG. This bit is set when bit 0 (CARDSTS) in the socket present state register (offset 08h, see Section 6.3) has changed state. For CardBus cards, this bit is set on the rising edge of the CSTSCHG signal. For 16-bit PC Cards, this bit is set on both transitions of the CSTSCHG signal. This bit is reset by writing a 1.

## 6.2 Socket Mask Register

This register allows software to control the CardBus card events which generate a status change interrupt. The state of these mask bits does not prevent the corresponding bits from reacting in the socket event register (offset 00h, see Section 6.1). See Table 6–3 for a complete description of the register contents.

<b>Bit</b>	31	30	29	28	27	26	25	24	23	22	21	20	19	18	17	16
<b>Name</b>	Socket mask															
<b>Type</b>	R	R	R	R	R	R	R	R	R	R	R	R	R	R	R	R
<b>Default</b>	0	0	0	0	0	0	0	0	0	0	0	0	0	0	0	0
<b>Bit</b>	15	14	13	12	11	10	9	8	7	6	5	4	3	2	1	0
<b>Name</b>	Socket mask															
<b>Type</b>	R	R	R	R	R	R	R	R	R	R	R	R	RW	RW	RW	RW
<b>Default</b>	0	0	0	0	0	0	0	0	0	0	0	0	0	0	0	0

Register: **Socket mask**  
 Offset: CardBus Socket Address + 04h  
 Type: Read-only, Read/Write  
 Default: 0000 0000h

**Table 6–3. Socket Mask Register Description**

BIT	SIGNAL	TYPE	FUNCTION
31–4	RSVD	R	These bits return 0s when read.
3	PWRMASK	RW	Power cycle. This bit masks bit 3 (PWRCYCLE) in the socket present state register (offset 08h, see Section 6.3) from causing a status change interrupt. 0 = PWRCYCLE event does not cause a CSC interrupt (default). 1 = PWRCYCLE event causes a CSC interrupt.
2–1	CDMASK	RW	Card detect mask. These bits mask bits 2 (CDETECT2) and 1 (CDETECT1) in the socket present state register (offset 08h, see Section 6.3) from causing a CSC interrupt. 00 = Insertion/removal does not cause a CSC interrupt (default). 01 = Reserved (undefined) 10 = Reserved (undefined) 11 = Insertion/removal causes a CSC interrupt.
0	CSTSMASK	RW	CSTSCHG mask. This bit masks bit 0 (CARDSTS) in the socket present state register (offset 08h, see Section 6.3) from causing a CSC interrupt. 0 = CARDSTS event does not cause a CSC interrupt (default). 1 = CARDSTS event causes a CSC interrupt.

### 6.3 Socket Present State Register

This register reports information about the socket interface. Writes to the socket force event register (offset 0Ch, see Section 6.4), as well as general socket interface status, are reflected here. Information about PC Card  $V_{CC}$  support and card type is only updated at each insertion. Also note that the PCI4510 device uses the  $\overline{CCD1}$  and  $\overline{CCD2}$  signals during card identification, and changes on these signals during this operation are not reflected in this register.

Bit	31	30	29	28	27	26	25	24	23	22	21	20	19	18	17	16
Name	Socket present state															
Type	R	R	R	R	R	R	R	R	R	R	R	R	R	R	R	R
Default	0	0	1	1	0	0	0	0	0	0	0	0	0	0	0	0
Bit	15	14	13	12	11	10	9	8	7	6	5	4	3	2	1	0
Name	Socket present state															
Type	R	R	R	R	R	R	R	R	R	R	R	R	R	R	R	R
Default	0	0	0	0	0	0	0	0	0	X	0	0	0	X	X	X

Register: **Socket present state**  
 Offset: CardBus Socket Address + 08h  
 Type: Read-only  
 Default: 3000 00XXh

**Table 6–4. Socket Present State Register Description**

BIT	SIGNAL	TYPE	FUNCTION
31	YVSOCKET	R	YV socket. This bit indicates whether or not the socket can supply $V_{CC} = Y.Y$ V to PC Cards. The PCI4510 device does not support Y.Y-V $V_{CC}$ ; therefore, this bit is always reset unless overridden by the socket force event register (offset 0Ch, see Section 6.4). This bit defaults to 0.
30	XVSOCKET	R	XV socket. This bit indicates whether or not the socket can supply $V_{CC} = X.X$ V to PC Cards. The PCI4510 device does not support X.X-V $V_{CC}$ ; therefore, this bit is always reset unless overridden by the socket force event register (offset 0Ch, see Section 6.4). This bit defaults to 0.
29	3VSOCKET	R	3-V socket. This bit indicates whether or not the socket can supply $V_{CC} = 3.3$ Vdc to PC Cards. The PCI4510 device does support 3.3-V $V_{CC}$ ; therefore, this bit is always set unless overridden by the socket force event register (offset 0Ch, see Section 6.4).
28	5VSOCKET	R	5-V socket. This bit indicates whether or not the socket can supply $V_{CC} = 5$ Vdc to PC Cards. The PCI4510 device does support 5-V $V_{CC}$ ; therefore, this bit is always set unless overridden by bit 6 of the device control register (PCI offset 92h, see Section 4.37).
27	ZVSUPPORT	R	Zoomed video support. This bit indicates whether or not the socket has support for zoomed video. 0 = ZV support disabled 1 = ZV support enabled
26–14	RSVD	R	These bits return 0s when read.
13	YVCARD	R	YV card. This bit indicates whether or not the PC Card inserted in the socket supports $V_{CC} = Y.Y$ Vdc. This bit can be set by writing a 1 to bit 13 (FYVCARD) in the socket force event register (offset 0Ch, see Section 6.4).
12	XVCARD	R	XV card. This bit indicates whether or not the PC Card inserted in the socket supports $V_{CC} = X.X$ Vdc. This bit can be set by writing a 1 to bit 12 (FXVCARD) in the socket force event register (offset 0Ch, see Section 6.4).
11	3VCARD	R	3-V card. This bit indicates whether or not the PC Card inserted in the socket supports $V_{CC} = 3.3$ Vdc. This bit can be set by writing a 1 to bit 11 (F3VCARD) in the socket force event register (offset 0Ch, see Section 6.4).
10	5VCARD	R	5-V card. This bit indicates whether or not the PC Card inserted in the socket supports $V_{CC} = 5$ Vdc. This bit can be set by writing a 1 to bit 10 (F5VCARD) in the socket force event register (offset 0Ch, see Section 6.4).
9	BADVCCREQ	R	Bad $V_{CC}$ request. This bit indicates that the host software has requested that the socket be powered at an invalid voltage. 0 = Normal operation (default) 1 = Invalid $V_{CC}$ request by host software



**Table 6–4. Socket Present State Register Description (Continued)**

BIT	SIGNAL	TYPE	FUNCTION
8	DATALOST	R	Data lost. This bit indicates that a PC Card removal event may have caused lost data because the cycle did not terminate properly or because write data still resides in the PCI4510 device. 0 = Normal operation (default) 1 = Potential data loss due to card removal
7	NOTACARD	R	Not a card. This bit indicates that an unrecognizable PC Card has been inserted in the socket. This bit is not updated until a valid PC Card is inserted into the socket. 0 = Normal operation (default) 1 = Unrecognizable PC Card detected
6	IREQCINT	R	READY( $\overline{\text{IREQ}}$ )/ $\overline{\text{CINT}}$ . This bit indicates the current status of the READY( $\overline{\text{IREQ}}$ )/ $\overline{\text{CINT}}$ signal at the PC Card interface. 0 = READY( $\overline{\text{IREQ}}$ )/ $\overline{\text{CINT}}$ is low. 1 = READY( $\overline{\text{IREQ}}$ )/ $\overline{\text{CINT}}$ is high.
5	CBCARD	R	CardBus card detected. This bit indicates that a CardBus PC Card is inserted in the socket. This bit is not updated until another card interrogation sequence occurs (card insertion).
4	16BITCARD	R	16-bit card detected. This bit indicates that a 16-bit PC Card is inserted in the socket. This bit is not updated until another card interrogation sequence occurs (card insertion).
3	PWRCYCLE	R	Power cycle. This bit indicates the status of each card powering request. This bit is encoded as: 0 = Socket is powered down (default). 1 = Socket is powered up.
2	CDETECT2	R	$\overline{\text{CCD2}}$ . This bit reflects the current status of the $\overline{\text{CCD2}}$ signal at the PC Card interface. Changes to this signal during card interrogation are not reflected here. 0 = $\overline{\text{CCD2}}$ is low (PC Card may be present) 1 = $\overline{\text{CCD2}}$ is high (PC Card not present)
1	CDETECT1	R	$\overline{\text{CCD1}}$ . This bit reflects the current status of the $\overline{\text{CCD1}}$ signal at the PC Card interface. Changes to this signal during card interrogation are not reflected here. 0 = $\overline{\text{CCD1}}$ is low (PC Card may be present). 1 = $\overline{\text{CCD1}}$ is high (PC Card not present).
0	CARDSTS	R	CSTSCHG. This bit reflects the current status of the CSTSCHG signal at the PC Card interface. 0 = CSTSCHG is low. 1 = CSTSCHG is high.

## 6.4 Socket Force Event Register

This register is used to force changes to the socket event register (offset 00h, see Section 6.1) and the socket present state register (offset 08h, see Section 6.3). Bit 14 (CVSTEST) in this register must be written when forcing changes that require card interrogation. See Table 6–5 for a complete description of the register contents.

Bit	31	30	29	28	27	26	25	24	23	22	21	20	19	18	17	16
<b>Name</b>	Socket force event															
<b>Type</b>	R	R	R	R	R	R	R	R	R	R	R	R	R	R	R	R
<b>Default</b>	0	0	0	0	0	0	0	0	0	0	0	0	0	0	0	0
Bit	15	14	13	12	11	10	9	8	7	6	5	4	3	2	1	0
<b>Name</b>	Socket force event															
<b>Type</b>	R	W	W	W	W	W	W	W	W	R	W	W	W	W	W	W
<b>Default</b>	X	X	X	X	X	X	X	X	X	X	X	X	X	X	X	X

Register: **Socket force event**  
 Offset: CardBus Socket Address + 0Ch  
 Type: Read-only, Write-only  
 Default: 0000 XXXXh

**Table 6–5. Socket Force Event Register Description**

BIT	SIGNAL	TYPE	FUNCTION
31–28	RSVD	R	These bits return 0s when read.
27	FZVSUPPORT	W	Force zoomed video support. Writes to this bit cause bit 27 (ZVSUPPORT) in the socket present state register (offset 08h, see Section 6.3) to be written.
26–15	RSVD	R	These bits return 0s when read.
14	CVSTEST	W	Card VS test. When this bit is set, the PCI4510 device reinterrogates the PC Card, updates the socket present state register (offset 08h, see Section 6.3), and re-enables the socket power control.
13	FYVCARD	W	Force YV card. Writes to this bit cause bit 13 (YVCARD) in the socket present state register (offset 08h, see Section 6.3) to be written. When set, this bit disables the socket power control.
12	FXVCARD	W	Force XV card. Writes to this bit cause bit 12 (XVCARD) in the socket present state register (offset 08h, see Section 6.3) to be written. When set, this bit disables the socket power control.
11	F3VCARD	W	Force 3-V card. Writes to this bit cause bit 11 (3VCARD) in the socket present state register (offset 08h, see Section 6.3) to be written. When set, this bit disables the socket power control.
10	F5VCARD	W	Force 5-V card. Writes to this bit cause bit 10 (5VCARD) in the socket present state register (offset 08h, see Section 6.3) to be written. When set, this bit disables the socket power control.
9	FBADVCCREQ	W	Force BadVccReq. Changes to bit 9 (BADVCCREQ) in the socket present state register (offset 08h, see Section 6.3) can be made by writing this bit.
8	FDATALOST	W	Force data lost. Writes to this bit cause bit 8 (DATALOST) in the socket present state register (offset 08h, see Section 6.3) to be written.
7	FNOTACARD	W	Force not a card. Writes to this bit cause bit 7 (NOTACARD) in the socket present state register (offset 08h, see Section 6.3) to be written.
6	RSVD	R	This bit returns 0 when read.
5	FCBCARD	W	Force CardBus card. Writes to this bit cause bit 5 (CBCARD) in the socket present state register (offset 08h, see Section 6.3) to be written.
4	F16BITCARD	W	Force 16-bit card. Writes to this bit cause bit 4 (16BITCARD) in the socket present state register (offset 08h, see Section 6.3) to be written.
3	FPWRCYCLE	W	Force power cycle. Writes to this bit cause bit 3 (PWREVENT) in the socket event register (offset 00h, see Section 6.1) to be written, and bit 3 (PWRCYCLE) in the socket present state register (offset 08h, see Section 6.3) is unaffected.
2	FCDETECT2	W	Force $\overline{\text{CCD2}}$ . Writes to this bit cause bit 2 (CD2EVENT) in the socket event register (offset 00h, see Section 6.1) to be written, and bit 2 (CDETECT2) in the socket present state register (offset 08h, see Section 6.3) is unaffected.
1	FCDETECT1	W	Force $\overline{\text{CCD1}}$ . Writes to this bit cause bit 1 (CD1EVENT) in the socket event register (offset 00h, see Section 6.1) to be written, and bit 1 (CDETECT1) in the socket present state register (offset 08h, see Section 6.3) is unaffected.
0	FCARDSTS	W	Force CSTSCHG. Writes to this bit cause bit 0 (CSTSEVENT) in the socket event register (offset 00h, see Section 6.1) to be written. Bit 0 (CARDSTS) in the socket present state register (offset 08h, see Section 6.3) is unaffected.

## 6.5 Socket Control Register

This register provides control of the voltages applied to the socket  $V_{PP}$  and  $V_{CC}$ . The PCI4510 device ensures that the socket is powered up only at acceptable voltages when a CardBus card is inserted. See Table 6–6 for a complete description of the register contents.

<b>Bit</b>	31	30	29	28	27	26	25	24	23	22	21	20	19	18	17	16
<b>Name</b>	Socket control															
<b>Type</b>	R	R	R	R	R	R	R	R	R	R	R	R	R	R	R	R
<b>Default</b>	0	0	0	0	0	0	0	0	0	0	0	0	0	0	0	0
<b>Bit</b>	15	14	13	12	11	10	9	8	7	6	5	4	3	2	1	0
<b>Name</b>	Socket control															
<b>Type</b>	R	R	R	R	R	R	RW	R	RW	RW	RW	RW	R	RW	RW	RW
<b>Default</b>	0	0	0	0	0	1	0	0	0	0	0	0	0	0	0	0

Register: **Socket control**  
 Offset: CardBus Socket Address + 10h  
 Type: Read-only, Read/Write  
 Default: 0000 0400h

**Table 6–6. Socket Control Register Description**

BIT	SIGNAL	TYPE	FUNCTION
31–12	RSVD	R	These bits return 0s when read.
11	ZV_ACTIVITY	R	This bit returns 0 when the ZVEN bits (bit 0) for both sockets are 0 (disabled). If either ZVEN bit is set to 1, then the ZV_ACTIVITY bit returns 1.
10	STANDARDZVREG	R	Standardized zoomed video register model supported. Because the PCI4510 device supports this register model, this bit is hardwired to 1.
9	ZVEN	RW	Zoomed video enable. This bit enables zoomed video for the socket.
8	RSVD	R	These bits return 0s when read.
7	STOPCLK	RW	This bit controls how the CardBus clock run state machine decides when to stop the CardBus clock to the CardBus card: 0 = The PCI4510 clock run master tries to stop the clock to the CardBus card under the following two conditions: The CardBus interface is idle for eight clocks, and There is a request from the PCI master to stop the PCI clock. 1 = The PCI4510 clock run master tries to stop the clock to the CardBus card under the following condition: The CardBus interface is idle for eight clocks. In summary, if this bit is set to 1, then the CardBus controller tries to stop the clock to the CardBus card independent of the PCI clock run signal. The only condition that has to be satisfied in this case is the CardBus interface sampled idle for eight clocks.
6–4	VCCCTRL	RW	$V_{CC}$ control. These bits are used to request card $V_{CC}$ changes. 000 = Request power off (default)                      100 = Request $V_{CC}$ = X.X V 001 = Reserved    101 = Request $V_{CC}$ = Y.Y V 010 = Request $V_{CC}$ = 5 V                                      110 = Reserved 011 = Request $V_{CC}$ = 3.3 V                                      111 = Reserved
3	RSVD	R	This bit returns 0 when read.
2–0	VPPCTRL	RW	$V_{PP}$ control. These bits are used to request card $V_{PP}$ changes. 000 = Request power off (default)                      100 = Request $V_{PP}$ = X.X V 001 = Request $V_{PP}$ = 12 V                                      101 = Request $V_{PP}$ = Y.Y V 010 = Request $V_{PP}$ = 5 V                                      110 = Reserved 011 = Request $V_{PP}$ = 3.3 V                                      111 = Reserved

## 6.6 Socket Power Management Register

This register provides power management control over the socket through a mechanism for slowing or stopping the clock on the card interface when the card is idle. See Table 6–7 for a complete description of the register contents.

Bit	31	30	29	28	27	26	25	24	23	22	21	20	19	18	17	16
Name	Socket power management															
Type	R	R	R	R	R	R	R	R	R	R	R	R	R	R	R	RW
Default	0	0	0	0	0	0	0	0	0	0	0	0	0	0	0	0
Bit	15	14	13	12	11	10	9	8	7	6	5	4	3	2	1	0
Name	Socket power management															
Type	R	R	R	R	R	R	R	R	R	R	R	R	R	R	R	RW
Default	0	0	0	0	0	0	0	0	0	0	0	0	0	0	0	0

Register: **Socket power management**  
 Offset: CardBus Socket Address + 20h  
 Type: Read-only, Read/Write  
 Default: 0000 0000h

**Table 6–7. Socket Power Management Register Description**

BIT	SIGNAL	TYPE	FUNCTION
31–26	RSVD	R	Reserved. These bits return 0s when read.
25	SKTACCES	R	Socket access status. This bit provides information on whether a socket access has occurred. This bit is cleared by a read access. 0 = No PC Card access has occurred (default). 1 = PC Card has been accessed.
24	SKTMODE	R	Socket mode status. This bit provides clock mode information. 0 = Normal clock operation 1 = Clock frequency has changed.
23–17	RSVD	R	These bits return 0s when read.
16	CLKCTRLLEN	RW	CardBus clock control enable. This bit, when set, enables clock control according to bit 0 (CLKCTRL). 0 = Clock control disabled (default) 1 = Clock control enabled
15–1	RSVD	R	These bits return 0s when read.
0	CLKCTRL	RW	CardBus clock control. This bit determines whether the CardBus $\overline{\text{CLKRUN}}$ protocol attempts to stop or slow the CardBus clock during <u>idle states</u> . Bit 16 (CLKCTRLLEN) enables this bit. 0 = Allows the CardBus $\overline{\text{CLKRUN}}$ protocol to attempt to stop the CardBus clock (default) 1 = Allows the CardBus $\overline{\text{CLKRUN}}$ protocol to attempt to slow the CardBus clock by a factor of 16

## 7 OHCI Controller Programming Model

This section describes the internal PCI configuration registers used to program the PCI4510 1394 open host controller interface. All registers are detailed in the same format: a brief description for each register is followed by the register offset and a bit table describing the reset state for each register.

A bit description table, typically included when the register contains bits of more than one type or purpose, indicates bit field names, a detailed field description, and field access tags which appear in the *type* column. Table 4–1 describes the field access tags.

PCI4510 device is a multifunction PCI device. The 1394 OHCI is integrated as PCI function 1. The function 1 configuration header is compliant with the *PCI Local Bus Specification* as a standard header. Table 7–1 illustrates the configuration header that includes both the predefined portion of the configuration space and the user-definable registers.

**Table 7–1. Function 1 Configuration Register Map**

REGISTER NAME				OFFSET
Device ID		Vendor ID		00h
Status		Command		04h
Class code			Revision ID	08h
BIST	Header type	Latency timer	Cache line size	0Ch
OHCI base address				10h
TI extension base address				14h
CardBus CIS base address				18h
Reserved				1Ch–27h
CardBus CIS pointer				28h
Subsystem ID		Subsystem vendor ID		2Ch
Reserved				30h
Reserved			PCI power management capabilities pointer	34h
Reserved				38h
MAX_LAT	MIN_GNT	Interrupt pin	Interrupt line	3Ch
PCI OHCI control				40h
Power management capabilities		Next item pointer	Capability ID	44h
PM data	PMCSR_BSE	Power management control and status		48h
Reserved				4Ch–ECh
PCI miscellaneous configuration				F0h
Link enhancement control				F4h
Subsystem access				F8h
Reserved				FCh

## 7.1 Vendor ID Register

The vendor ID register contains a value allocated by the PCI SIG and identifies the manufacturer of the PCI device. The vendor ID assigned to Texas Instruments is 104Ch.

Bit	15	14	13	12	11	10	9	8	7	6	5	4	3	2	1	0
Name	Vendor ID															
Type	R	R	R	R	R	R	R	R	R	R	R	R	R	R	R	R
Default	0	0	0	1	0	0	0	0	0	1	0	0	1	1	0	0

Register: **Vendor ID**  
 Offset: 00h  
 Type: Read-only  
 Default: 104Ch

## 7.2 Device ID Register

The device ID register contains a value assigned to the PCI4510 device by Texas Instruments. The device identification for the PCI4510 device is 8029h.

Bit	15	14	13	12	11	10	9	8	7	6	5	4	3	2	1	0
Name	Device ID															
Type	R	R	R	R	R	R	R	R	R	R	R	R	R	R	R	R
Default	1	0	0	0	0	0	0	0	0	0	1	0	1	0	0	1

Register: **Device ID**  
 Offset: 02h  
 Type: Read-only  
 Default: 8029h

## 7.3 Command Register

The command register provides control over the PCI4510 interface to the PCI bus. All bit functions adhere to the definitions in the *PCI Local Bus Specification*, as seen in the following bit descriptions. See Table 7–2 for a complete description of the register contents.

Bit	15	14	13	12	11	10	9	8	7	6	5	4	3	2	1	0
Name	Command															
Type	R	R	R	R	R	R	R	RW	R	RW	R	RW	R	RW	RW	R
Default	0	0	0	0	0	0	0	0	0	0	0	0	0	0	0	0

Register: **Command**  
 Offset: 04h  
 Type: Read/Write, Read-only  
 Default: 0000h

**Table 7–2. Command Register Description**

BIT	FIELD NAME	TYPE	DESCRIPTION
15–10	RSVD	R	Reserved. Bits 15–10 return 0s when read.
9	FBB_ENB	R	Fast back-to-back enable. The PCI4510 device does not generate fast back-to-back transactions; therefore, bit 9 returns 0 when read.
8	SERR_ENB	RW	$\overline{\text{SERR}}$ enable. When bit 8 is set to 1, the PCI4510 $\overline{\text{SERR}}$ driver is enabled. $\overline{\text{SERR}}$ can be asserted after detecting an address parity error on the PCI bus.
7	STEP_ENB	R	Address/data stepping control. The PCI4510 device does not support address/data stepping; therefore, bit 7 is hardwired to 0.
6	PERR_ENB	RW	Parity error enable. When bit 6 is set to 1, the PCI4510 device is enabled to drive $\overline{\text{PERR}}$ response to parity errors through the $\overline{\text{PERR}}$ signal.
5	VGA_ENB	R	VGA palette snoop enable. The PCI4510 device does not feature VGA palette snooping; therefore, bit 5 returns 0 when read.
4	MWI_ENB	RW	Memory write and invalidate enable. When bit 4 is set to 1, the PCI4510 device is enabled to generate MWI PCI bus commands. If this bit is cleared, then the PCI4510 device generates memory write commands instead.
3	SPECIAL	R	Special cycle enable. The PCI4510 function does not respond to special cycle transactions; therefore, bit 3 returns 0 when read.
2	MASTER_ENB	RW	Bus master enable. When bit 2 is set to 1, the PCI4510 device is enabled to initiate cycles on the PCI bus.
1	MEMORY_ENB	RW	Memory response enable. Setting bit 1 to 1 enables the PCI4510 device to respond to memory cycles on the PCI bus. This bit must be set to access OHCI registers.
0	IO_ENB	R	I/O space enable. The PCI4510 device does not implement any I/O-mapped functionality; therefore, bit 0 returns 0 when read.

## 7.4 Status Register

The status register provides status over the PCI4510 interface to the PCI bus. All bit functions adhere to the definitions in the *PCI Local Bus Specification*, as seen in the following bit descriptions. See Table 7–3 for a complete description of the register contents.

Bit	15	14	13	12	11	10	9	8	7	6	5	4	3	2	1	0
Name	Status															
Type	RCU	RCU	RCU	RCU	RCU	R	R	RCU	R	R	R	R	R	R	R	R
Default	0	0	0	0	0	0	1	0	0	0	0	1	0	0	0	0

Register: **Status**  
 Offset: 06h  
 Type: Read/Clear/Update, Read-only  
 Default: 0210h

**Table 7–3. Status Register Description**

BIT	FIELD NAME	TYPE	DESCRIPTION
15	PAR_ERR	RCU	Detected parity error. Bit 15 is set to 1 when either an address parity or data parity error is detected.
14	SYS_ERR	RCU	Signaled system error. Bit 14 is set to 1 when $\overline{SERR}$ is enabled and the PCI4510 device has signaled a system error to the host.
13	MABORT	RCU	Received master abort. Bit 13 is set to 1 when a cycle initiated by the PCI4510 device on the PCI bus has been terminated by a master abort.
12	TABORT_REC	RCU	Received target abort. Bit 12 is set to 1 when a cycle initiated by the PCI4510 device on the PCI bus was terminated by a target abort.
11	TABORT_SIG	RCU	Signaled target abort. Bit 11 is set to 1 by the PCI4510 device when it terminates a transaction on the PCI bus with a target abort.
10–9	PCI_SPEED	R	DEVSEL timing. Bits 10 and 9 encode the timing of $\overline{DEVSEL}$ and are hardwired to 01b, indicating that the PCI4510 device asserts this signal at a medium speed on nonconfiguration cycle accesses.
8	DATAPAR	RCU	Data parity error detected. Bit 8 is set to 1 when the following conditions have been met: a. $\overline{PERR}$ was asserted by any PCI device including the PCI4510 device. b. The PCI4510 device was the bus master during the data parity error. c. Bit 6 (PERR_EN) in the command register at offset 04h in the PCI configuration space (see Section 7.3) is set to 1.
7	FBB_CAP	R	Fast back-to-back capable. The PCI4510 device cannot accept fast back-to-back transactions; therefore, bit 7 is hardwired to 0.
6	UDF	R	User-definable features (UDF) supported. The PCI4510 device does not support the UDF; therefore, bit 6 is hardwired to 0.
5	66MHZ	R	66-MHz capable. The PCI4510 device operates at a maximum PCLK frequency of 33 MHz; therefore, bit 5 is hardwired to 0.
4	CAPLIST	R	Capabilities list. Bit 4 returns 1 when read, indicating that capabilities additional to standard PCI are implemented. The linked list of PCI power-management capabilities is implemented in this function.
3–0	RSVD	R	Reserved. Bits 3–0 return 0s when read.



## 7.5 Class Code and Revision ID Register

The class code and revision ID register categorizes the PCI4510 device as a serial bus controller (0Ch), controlling an IEEE 1394 bus (00h), with an OHCI programming model (10h). Furthermore, the TI chip revision is indicated in the least significant byte. See Table 7–4 for a complete description of the register contents.

<b>Bit</b>	<b>31</b>	<b>30</b>	<b>29</b>	<b>28</b>	<b>27</b>	<b>26</b>	<b>25</b>	<b>24</b>	<b>23</b>	<b>22</b>	<b>21</b>	<b>20</b>	<b>19</b>	<b>18</b>	<b>17</b>	<b>16</b>
<b>Name</b>	Class code and revision ID															
<b>Type</b>	R	R	R	R	R	R	R	R	R	R	R	R	R	R	R	R
<b>Default</b>	0	0	0	0	1	1	0	0	0	0	0	0	0	0	0	0
<b>Bit</b>	<b>15</b>	<b>14</b>	<b>13</b>	<b>12</b>	<b>11</b>	<b>10</b>	<b>9</b>	<b>8</b>	<b>7</b>	<b>6</b>	<b>5</b>	<b>4</b>	<b>3</b>	<b>2</b>	<b>1</b>	<b>0</b>
<b>Name</b>	Class code and revision ID															
<b>Type</b>	R	R	R	R	R	R	R	R	R	R	R	R	R	R	R	R
<b>Default</b>	0	0	0	1	0	0	0	0	0	0	0	0	0	0	0	0

Register: **Class code and revision ID**  
 Offset: 08h  
 Type: Read-only  
 Default: 0C00 1000h

**Table 7–4. Class Code and Revision ID Register Description**

BIT	FIELD NAME	TYPE	DESCRIPTION
31–24	BASECLASS	R	Base class. This field returns 0Ch when read, which broadly classifies the function as a serial bus controller.
23–16	SUBCLASS	R	Subclass. This field returns 00h when read, which specifically classifies the function as controlling an IEEE 1394 serial bus.
15–8	PGMIF	R	Programming interface. This field returns 10h when read, which indicates that the programming model is compliant with the <i>1394 Open Host Controller Interface Specification</i> .
7–0	CHIPREV	R	Silicon revision. This field returns 00h when read, which indicates the silicon revision of the PCI4510 device.

## 7.6 Latency Timer and Class Cache Line Size Register

The latency timer and class cache line size register is programmed by host BIOS to indicate system cache line size and the latency timer associated with the PCI4510 device. See Table 7–5 for a complete description of the register contents.

<b>Bit</b>	<b>15</b>	<b>14</b>	<b>13</b>	<b>12</b>	<b>11</b>	<b>10</b>	<b>9</b>	<b>8</b>	<b>7</b>	<b>6</b>	<b>5</b>	<b>4</b>	<b>3</b>	<b>2</b>	<b>1</b>	<b>0</b>
<b>Name</b>	Latency timer and class cache line size															
<b>Type</b>	RW	RW	RW	RW	RW	RW	RW	RW	RW	RW	RW	RW	RW	RW	RW	RW
<b>Default</b>	0	0	0	0	0	0	0	0	0	0	0	0	0	0	0	0

Register: **Latency timer and class cache line size**  
 Offset: 0Ch  
 Type: Read/Write  
 Default: 0000h

**Table 7–5. Latency Timer and Class Cache Line Size Register Description**

BIT	FIELD NAME	TYPE	DESCRIPTION
15–8	LATENCY_TIMER	RW	PCI latency timer. The value in this register specifies the latency timer for the PCI4510 device, in units of PCI clock cycles. When the PCI4510 device is a PCI bus initiator and asserts FRAME, the latency timer begins counting from zero. If the latency timer expires before the PCI4510 transaction has terminated, then the PCI4510 device terminates the transaction when its GNT is deasserted.
7–0	CACHELINE_SZ	RW	Cache line size. This value is used by the PCI4510 device during memory write and invalidate, memory-read line, and memory-read multiple transactions.

## 7.7 Header Type and BIST Register

The header type and built-in self-test (BIST) register indicates the PCI4510 PCI header type and no built-in self-test. See Table 7–6 for a complete description of the register contents.

Bit	15	14	13	12	11	10	9	8	7	6	5	4	3	2	1	0
<b>Name</b>	Header type and BIST															
<b>Type</b>	R	R	R	R	R	R	R	R	R	R	R	R	R	R	R	R
<b>Default</b>	0	0	0	0	0	0	0	0	0	0	0	0	0	0	0	0

Register: **Header type and BIST**  
 Offset: 0Eh  
 Type: Read-only  
 Default: 0000h

**Table 7–6. Header Type and BIST Register Description**

BIT	FIELD NAME	TYPE	DESCRIPTION
15–8	BIST	R	Built-in self-test. The PCI4510 device does not include a BIST; therefore, this field returns 00h when read.
7–0	HEADER_TYPE	R	PCI header type. The PCI4510 device includes the standard PCI header, which is communicated by returning 00h when this field is read.

## 7.8 OHCI Base Address Register

The OHCI base address register is programmed with a base address referencing the memory-mapped OHCI control. When BIOS writes all 1s to this register, the value read back is FFFF F800h, indicating that at least 2K bytes of memory address space are required for the OHCI registers. See Table 7–7 for a complete description of the register contents.

Bit	31	30	29	28	27	26	25	24	23	22	21	20	19	18	17	16
<b>Name</b>	OHCI base address															
<b>Type</b>	RW	RW	RW	RW	RW	RW	RW	RW	RW	RW	RW	RW	RW	RW	RW	RW
<b>Default</b>	0	0	0	0	0	0	0	0	0	0	0	0	0	0	0	0
Bit	15	14	13	12	11	10	9	8	7	6	5	4	3	2	1	0
<b>Name</b>	OHCI base address															
<b>Type</b>	RW	RW	RW	RW	RW	R	R	R	R	R	R	R	R	R	R	R
<b>Default</b>	0	0	0	0	0	0	0	0	0	0	0	0	0	0	0	0

Register: **OHCI base address**  
 Offset: 10h  
 Type: Read/Write, Read-only  
 Default: 0000 0000h

**Table 7–7. OHCI Base Address Register Description**

BIT	FIELD NAME	TYPE	DESCRIPTION
31–11	OHCIREG_PTR	RW	OHCI register pointer. This field specifies the upper 21 bits of the 32-bit OHCI base address register.
10–4	OHCI_SZ	R	OHCI register size. This field returns 0s when read, indicating that the OHCI registers require a 2K-byte region of memory.
3	OHCI_PF	R	OHCI register prefetch. Bit 3 returns 0 when read, indicating that the OHCI registers are nonprefetchable.
2–1	OHCI_MEMTYPE	R	OHCI memory type. This field returns 0s when read, indicating that the OHCI base address register is 32 bits wide and mapping can be done anywhere in the 32-bit memory space.
0	OHCI_MEM	R	OHCI memory indicator. Bit 0 returns 0 when read, indicating that the OHCI registers are mapped into system memory space.

## 7.9 TI Extension Base Address Register

The TI extension base address register is programmed with a base address referencing the memory-mapped TI extension registers. When BIOS writes all 1s to this register, the value read back is FFFF C000h, indicating that at least 16K bytes of memory address space are required for the TI registers. See Table 7–8 for a complete description of the register contents.

<b>Bit</b>	<b>31</b>	<b>30</b>	<b>29</b>	<b>28</b>	<b>27</b>	<b>26</b>	<b>25</b>	<b>24</b>	<b>23</b>	<b>22</b>	<b>21</b>	<b>20</b>	<b>19</b>	<b>18</b>	<b>17</b>	<b>16</b>
<b>Name</b>	TI extension base address															
<b>Type</b>	RW	RW	RW	RW	RW	RW	RW	RW	RW	RW	RW	RW	RW	RW	RW	RW
<b>Default</b>	0	0	0	0	0	0	0	0	0	0	0	0	0	0	0	0
<b>Bit</b>	<b>15</b>	<b>14</b>	<b>13</b>	<b>12</b>	<b>11</b>	<b>10</b>	<b>9</b>	<b>8</b>	<b>7</b>	<b>6</b>	<b>5</b>	<b>4</b>	<b>3</b>	<b>2</b>	<b>1</b>	<b>0</b>
<b>Name</b>	TI extension base address															
<b>Type</b>	RW	RW	R	R	R	R	R	R	R	R	R	R	R	R	R	R
<b>Default</b>	0	0	0	0	0	0	0	0	0	0	0	0	0	0	0	0

Register: **TI extension base address**  
 Offset: 14h  
 Type: Read/Write, Read-only  
 Default: 0000 0000h

**Table 7–8. TI Base Address Register Description**

BIT	FIELD NAME	TYPE	DESCRIPTION
31–14	TIREG_PTR	RW	TI register pointer. This field specifies the upper 18 bits of the 32-bit TI base address register.
13–4	TI_SZ	R	TI register size. This field returns 0s when read, indicating that the TI registers require a 16K-byte region of memory.
3	TI_PF	R	TI register prefetch. Bit 3 returns 0 when read, indicating that the TI registers are nonprefetchable.
2–1	TI_MEMTYPE	R	TI memory type. This field returns 0s when read, indicating that the TI base address register is 32 bits wide and mapping can be done anywhere in the 32-bit memory space.
0	TI_MEM	R	TI memory indicator. Bit 0 returns 0 when read, indicating that the TI registers are mapped into system memory space.

## 7.10 CardBus CIS Base Address Register

This register returns 0s when read because the 1394 function is not implemented as a CardBus device.

<b>Bit</b>	<b>31</b>	<b>30</b>	<b>29</b>	<b>28</b>	<b>27</b>	<b>26</b>	<b>25</b>	<b>24</b>	<b>23</b>	<b>22</b>	<b>21</b>	<b>20</b>	<b>19</b>	<b>18</b>	<b>17</b>	<b>16</b>
<b>Name</b>	CardBus CIS base address															
<b>Type</b>	R	R	R	R	R	R	R	R	R	R	R	R	R	R	R	R
<b>Default</b>	0	0	0	0	0	0	0	0	0	0	0	0	0	0	0	0
<b>Bit</b>	<b>15</b>	<b>14</b>	<b>13</b>	<b>12</b>	<b>11</b>	<b>10</b>	<b>9</b>	<b>8</b>	<b>7</b>	<b>6</b>	<b>5</b>	<b>4</b>	<b>3</b>	<b>2</b>	<b>1</b>	<b>0</b>
<b>Name</b>	CardBus CIS base address															
<b>Type</b>	R	R	R	R	R	R	R	R	R	R	R	R	R	R	R	R
<b>Default</b>	0	0	0	0	0	0	0	0	0	0	0	0	0	0	0	0

Register: **CardBus CIS base address**  
 Offset: 18h  
 Type: Read-only  
 Default: 0000 0000h

## 7.11 CardBus CIS Pointer Register

This register returns 0s when read because the 1394 function is not implemented as a CadBus device.

<b>Bit</b>	<b>31</b>	<b>30</b>	<b>29</b>	<b>28</b>	<b>27</b>	<b>26</b>	<b>25</b>	<b>24</b>	<b>23</b>	<b>22</b>	<b>21</b>	<b>20</b>	<b>19</b>	<b>18</b>	<b>17</b>	<b>16</b>
<b>Name</b>	CardBus CIS pointer															
<b>Type</b>	R	R	R	R	R	R	R	R	R	R	R	R	R	R	R	R
<b>Default</b>	0	0	0	0	0	0	0	0	0	0	0	0	0	0	0	0
<b>Bit</b>	<b>15</b>	<b>14</b>	<b>13</b>	<b>12</b>	<b>11</b>	<b>10</b>	<b>9</b>	<b>8</b>	<b>7</b>	<b>6</b>	<b>5</b>	<b>4</b>	<b>3</b>	<b>2</b>	<b>1</b>	<b>0</b>
<b>Name</b>	CardBus CIS pointer															
<b>Type</b>	R	R	R	R	R	R	R	R	R	R	R	R	R	R	R	R
<b>Default</b>	0	0	0	0	0	0	0	0	0	0	0	0	0	0	0	0

Register: **CardBus CIS pointer**  
 Offset: 28h  
 Type: Read-only  
 Default: 0000 0000h

## 7.12 Subsystem Identification Register

The subsystem identification register is used for system and option card identification purposes. This register can be initialized from the serial EEPROM or programmed via the subsystem access register at offset F8h in the PCI configuration space (see Section 7.25). See Table 7–9 for a complete description of the register contents.

<b>Bit</b>	<b>31</b>	<b>30</b>	<b>29</b>	<b>28</b>	<b>27</b>	<b>26</b>	<b>25</b>	<b>24</b>	<b>23</b>	<b>22</b>	<b>21</b>	<b>20</b>	<b>19</b>	<b>18</b>	<b>17</b>	<b>16</b>
<b>Name</b>	Subsystem identification															
<b>Type</b>	RU	RU	RU	RU	RU	RU	RU	RU	RU	RU	RU	RU	RU	RU	RU	RU
<b>Default</b>	0	0	0	0	0	0	0	0	0	0	0	0	0	0	0	0
<b>Bit</b>	<b>15</b>	<b>14</b>	<b>13</b>	<b>12</b>	<b>11</b>	<b>10</b>	<b>9</b>	<b>8</b>	<b>7</b>	<b>6</b>	<b>5</b>	<b>4</b>	<b>3</b>	<b>2</b>	<b>1</b>	<b>0</b>
<b>Name</b>	Subsystem identification															
<b>Type</b>	RU	RU	RU	RU	RU	RU	RU	RU	RU	RU	RU	RU	RU	RU	RU	RU
<b>Default</b>	0	0	0	0	0	0	0	0	0	0	0	0	0	0	0	0

Register: **Subsystem identification**  
 Offset: 2Ch  
 Type: Read/Update  
 Default: 0000 0000h

**Table 7–9. Subsystem Identification Register Description**

<b>BIT</b>	<b>FIELD NAME</b>	<b>TYPE</b>	<b>DESCRIPTION</b>
31–16	OHCI_SSID	RU	Subsystem device ID. This field indicates the subsystem device ID.
15–0	OHCI_SVID	RU	Subsystem vendor ID. This field indicates the subsystem vendor ID.

### 7.13 Power Management Capabilities Pointer Register

The power management capabilities pointer register provides a pointer into the PCI configuration header where the power-management register block resides. The PCI4510 configuration header doublewords at offsets 44h and 48h provide the power-management registers. This register is read-only and returns 44h when read.

Bit	7	6	5	4	3	2	1	0
Name	Power management capabilities pointer							
Type	R	R	R	R	R	R	R	R
Default	0	1	0	0	0	1	0	0

Register: **Power management capabilities pointer**  
 Offset: 34h  
 Type: Read-only  
 Default: 44h

### 7.14 Interrupt Line Register

The interrupt line register communicates interrupt line routing information. See Table 7–10 for a complete description of the register contents.

Bit	7	6	5	4	3	2	1	0
Name	Interrupt line							
Type	RW	RW	RW	RW	RW	RW	RW	RW
Default	0	0	0	0	0	0	0	0

Register: **Interrupt line**  
 Offset: 3Ch  
 Type: Read/Write  
 Default: 00h

**Table 7–10. Interrupt Line Register Description**

BIT	FIELD NAME	TYPE	DESCRIPTION
7–0	INTR_LINE	RW	Interrupt line. This field is programmed by the system and indicates to software which interrupt line the PCI4510 PCI_INTA is connected to.

## 7.15 Interrupt Pin Register

The value read from this register is function dependent, and depends on interrupt tie bit 29 (INTRTIE) in the system control register (Function 0, PCI offset 80h, see Section 4.28). INTRTIE is compatible with other TI CardBus controllers and ties  $\overline{\text{INTA}}$  to  $\overline{\text{INTB}}$  internally. The internal interrupt connections set by INTRTIE are communicated to host software through this standard register interface. Refer to Table 7–11 for a complete description of the register contents.

Bit	7	6	5	4	3	2	1	0
Name	Interrupt pin							
Type	R	R	R	R	R	R	R	R
Default	0	0	0	0	0	0	1	0

Register: **Interrupt pin**  
 Offset: 3Dh  
 Type: Read-only  
 Default: 02h

**Table 7–11. PCI Interrupt Pin Register—Read-Only INTPIN Per Function**

INTRTIE BIT	INTPIN FUNCTION 0 (CARDBUS)	INTPIN FUNCTION 1 (1394 OHCI)
0	01h ( $\overline{\text{INTA}}$ )	02h ( $\overline{\text{INTB}}$ )
1	01h ( $\overline{\text{INTA}}$ )	01h ( $\overline{\text{INTA}}$ )

† When configuring the PCI4510 functions to share PCI interrupts, multifunction terminal MFUNC3 must be configured as IRQSER prior to setting the INTRTIE bit.

## 7.16 MIN\_GNT and MAX\_LAT Register

The MIN\_GNT and MAX\_LAT register communicates to the system the desired setting of bits 15–8 in the latency timer and class cache line size register at offset 0Ch in the PCI configuration space (see Section 7.6). If a serial EEPROM is detected, then the contents of this register are loaded through the serial EEPROM interface after a  $\overline{\text{GRST}}$ . If no serial EEPROM is detected, then this register returns a default value that corresponds to the MAX\_LAT = 4, MIN\_GNT = 2. See Table 7–12 for a complete description of the register contents.

Bit	15	14	13	12	11	10	9	8	7	6	5	4	3	2	1	0
Name	MIN_GNT and MAX_LAT															
Type	RU	RU	RU	RU	RU	RU	RU	RU	RU	RU	RU	RU	RU	RU	RU	RU
Default	0	0	0	0	0	1	0	0	0	0	0	0	0	0	1	0

Register: **MIN\_GNT and MAX\_LAT**  
 Offset: 3Eh  
 Type: Read/Update  
 Default: 0402h

**Table 7–12. MIN\_GNT and MAX\_LAT Register Description**

BIT	FIELD NAME	TYPE	DESCRIPTION
15–8	MAX_LAT	RU	Maximum latency. The contents of this field may be used by host BIOS to assign an arbitration priority level to the PCI4510 device. The default for this register indicates that the PCI4510 device may need to access the PCI bus as often as every 0.25 $\mu\text{s}$ ; thus, an extremely high priority level is requested. The contents of this field may also be loaded through the serial EEPROM.
7–0	MIN_GNT	RU	Minimum grant. The contents of this field may be used by host BIOS to assign a latency timer register value to the PCI4510 device. The default for this register indicates that the PCI4510 device may need to sustain burst transfers for nearly 64 $\mu\text{s}$ and thus request a large value be programmed in bits 15–8 of the PCI4510 latency timer and class cache line size register at offset 0Ch in the PCI configuration space (see Section 7.6).

## 7.17 OHCI Control Register

The PCI OHCI control register is defined by the *1394 Open Host Controller Interface Specification* and provides a bit for big endian PCI support. See Table 7–13 for a complete description of the register contents.

Bit	31	30	29	28	27	26	25	24	23	22	21	20	19	18	17	16
Name	OHCI control															
Type	R	R	R	R	R	R	R	R	R	R	R	R	R	R	R	R
Default	0	0	0	0	0	0	0	0	0	0	0	0	0	0	0	0
Bit	15	14	13	12	11	10	9	8	7	6	5	4	3	2	1	0
Name	OHCI control															
Type	R	R	R	R	R	R	R	R	R	R	R	R	R	R	R	RW
Default	0	0	0	0	0	0	0	0	0	0	0	0	0	0	0	0

Register: **OHCI control**  
 Offset: 40h  
 Type: Read/Write, Read-only  
 Default: 0000 0000h

**Table 7–13. OHCI Control Register Description**

BIT	FIELD NAME	TYPE	DESCRIPTION
31–1	RSVD	R	Reserved. Bits 31–1 return 0s when read.
0	GLOBAL_SWAP	RW	When bit 0 is set to 1, all quadlets read from and written to the PCI interface are byte-swapped (big endian).

## 7.18 Capability ID and Next Item Pointer Registers

The capability ID and next item pointer register identifies the linked-list capability item and provides a pointer to the next capability item. See Table 7–14 for a complete description of the register contents.

Bit	15	14	13	12	11	10	9	8	7	6	5	4	3	2	1	0
Name	Capability ID and next item pointer															
Type	R	R	R	R	R	R	R	R	R	R	R	R	R	R	R	R
Default	0	0	0	0	0	0	0	0	0	0	0	0	0	0	0	1

Register: **Capability ID and next item pointer**  
 Offset: 44h  
 Type: Read-only  
 Default: 0001h

**Table 7–14. Capability ID and Next Item Pointer Registers Description**

BIT	FIELD NAME	TYPE	DESCRIPTION
15–8	NEXT_ITEM	R	Next item pointer. The PCI4510 device supports only one additional capability that is communicated to the system through the extended capabilities list; therefore, this field returns 00h when read.
7–0	CAPABILITY_ID	R	Capability identification. This field returns 01h when read, which is the unique ID assigned by the PCI SIG for PCI power-management capability.

## 7.19 Power Management Capabilities Register

The power management capabilities register indicates the capabilities of the PCI4510 device related to PCI power management. See Table 7–15 for a complete description of the register contents.

Bit	15	14	13	12	11	10	9	8	7	6	5	4	3	2	1	0
Name	Power management capabilities															
Type	RU	R	R	R	R	R	R	R	R	R	R	R	R	R	R	R
Default	0	1	1	1	1	1	1	0	0	0	0	0	0	0	1	0

Register: **Power management capabilities**  
 Offset: 46h  
 Type: Read/Update, Read-only  
 Default: 7E02h

**Table 7–15. Power Management Capabilities Register Description**

BIT	FIELD NAME	TYPE	DESCRIPTION
15	PME_D3COLD	RU	$\overline{\text{PME}}$ support from D3 <sub>cold</sub> . This bit can be set to 1 or cleared to 0 via bit 15 (PME_D3COLD) in the PCI miscellaneous configuration register at offset F0h in the PCI configuration space (see Section 7.23). The PCI miscellaneous configuration register is loaded from ROM. When this bit is set to 1, it indicates that the PCI4510 device is capable of generating a $\overline{\text{PME}}$ wake event from D3 <sub>cold</sub> . This bit state is dependent upon the PCI4510 V <sub>AUX</sub> implementation and may be configured by using bit 15 (PME_D3COLD) in the PCI miscellaneous configuration register (see Section 7.23).
14–11	PME_SUPPORT	R	$\overline{\text{PME}}$ support. This 4-bit field indicates the power states from which the PCI4510 device may assert $\overline{\text{PME}}$ . This field returns a value of 1111b by default, indicating that $\overline{\text{PME}}$ may be asserted from the D3 <sub>hot</sub> , D2, D1, and D0 power states.
10	D2_SUPPORT	R	D2 support. Bit 10 is hardwired to 1, indicating that the PCI4510 device supports the D2 power state.
9	D1_SUPPORT	R	D1 support. Bit 9 is hardwired to 1, indicating that the PCI4510 device supports the D1 power state.
8–6	AUX_CURRENT	R	Auxiliary current. This 3-bit field reports the 3.3-V <sub>AUX</sub> auxiliary current requirements. When bit 15 (PME_D3COLD) is cleared, this field returns 000b; otherwise, it returns 001b. 000b = Self-powered 001b = 55 mA (3.3-V <sub>AUX</sub> maximum current required)
5	DSI	R	Device-specific initialization. This bit returns 0 when read, indicating that the PCI4510 device does not require special initialization beyond the standard PCI configuration header before a generic class driver is able to use it.
4	RSVD	R	Reserved. Bit 4 returns 0 when read.
3	PME_CLK	R	$\overline{\text{PME}}$ clock. This bit returns 0 when read, indicating that no host bus clock is required for the PCI4510 device to generate $\overline{\text{PME}}$ .
2–0	PM_VERSION	R	Power-management version. This field returns 010b when read, indicating that the PCI4510 device is compatible with the registers described in the <i>PCI Bus Power Management Interface Specification</i> (Revision 1.1).



## 7.20 Power Management Control and Status Register

The power management control and status register implements the control and status of the PCI power-management function. This register is not affected by the internally generated reset caused by the transition from the D3<sub>hot</sub> to D0 state. See Table 7–16 for a complete description of the register contents.

Bit	15	14	13	12	11	10	9	8	7	6	5	4	3	2	1	0
<b>Name</b>	Power management control and status															
<b>Type</b>	RWC	R	R	R	R	R	R	RW	R	R	R	R	R	R	RW	RW
<b>Default</b>	0	0	0	0	0	0	0	0	0	0	0	0	0	0	0	0

Register: **Power management control and status**  
 Offset: 48h  
 Type: Read/Clear, Read/Write, Read-only  
 Default: 0000h

**Table 7–16. Power Management Control and Status Register Description**

BIT	FIELD NAME	TYPE	DESCRIPTION
15	PME_STS	RWC	Bit 15 is set to 1 when the PCI4510 device normally asserts the $\overline{\text{PME}}$ signal independent of the state of bit 8 (PME_ENB). This bit is cleared by a writeback of 1, which also clears the $\overline{\text{PME}}$ signal driven by the PCI4510 device. Writing a 0 to this bit has no effect.
14–13	DATA_SCALE	R	This field returns 0s, because the data register is not implemented.
12–9	DATA_SELECT	R	This field returns 0s, because the data register is not implemented.
8	PME_ENB	RW	When bit 8 is set to 1, $\overline{\text{PME}}$ assertion is enabled. When bit 8 is cleared, $\overline{\text{PME}}$ assertion is disabled. This bit defaults to 0 if the function does not support $\overline{\text{PME}}$ generation from D3 <sub>Cold</sub> . If the function supports $\overline{\text{PME}}$ from D3 <sub>Cold</sub> , then this bit is sticky and must be explicitly cleared by the operating system each time it is initially loaded.
7–2	RSVD	R	Reserved. Bits 7–2 return 0s when read.
1–0	PWR_STATE	RW	Power state. This 2-bit field sets the PCI4510 device power state and is encoded as follows: 00 = Current power state is D0. 01 = Current power state is D1. 10 = Current power state is D2. 11 = Current power state is D3.

## 7.21 Power Management Extension Registers

The power management extension register provides extended power-management features not applicable to the PCI4510 device; thus, it is read-only and returns 0 when read. See Table 7–17 for a complete description of the register contents.

Bit	15	14	13	12	11	10	9	8	7	6	5	4	3	2	1	0
<b>Name</b>	Power management extension															
<b>Type</b>	R	R	R	R	R	R	R	R	R	R	R	R	R	R	R	R
<b>Default</b>	0	0	0	0	0	0	0	0	0	0	0	0	0	0	0	0

Register: **Power management extension**  
 Offset: 4Ah  
 Type: Read-only  
 Default: 0000h

**Table 7–17. Power Management Extension Registers Description**

BIT	FIELD NAME	TYPE	DESCRIPTION
15–0	RSVD	R	Reserved. Bits 15–0 return 0s when read.

## 7.22 PCI PHY Control Register

The PCI PHY control register provides a method for enabling the PHY CNA output. See Table 7–18 for a complete description of the register contents.

Bit	31	30	29	28	27	26	25	24	23	22	21	20	19	18	17	16
Name	PCI PHY control															
Type	R	R	R	R	R	R	R	R	R	R	R	R	R	R	R	R
Default	0	0	0	0	0	0	0	0	0	0	0	0	0	0	0	0
Bit	15	14	13	12	11	10	9	8	7	6	5	4	3	2	1	0
Name	PCI PHY control															
Type	R	R	R	R	R	R	R	R	RW	R	R	R	R	R	R	R
Default	0	0	0	0	0	0	0	0	0	0	0	0	1	0	0	0

Register: **PCI PHY control**  
 Offset: ECh  
 Type: Read/Write, Read-only  
 Default: 0000 0008h

**Table 7–18. PCI PHY Control Register**

BIT	FIELD NAME	TYPE	DESCRIPTION
31–8	RSVD	R	Reserved. Bits 31–8 return 0s when read.
7	CNAOUT	RW	When bit 7 is set to 1, the PHY CNA output is routed to terminal 96. When implementing a serial EEPROM, this bit can be set by programming bit 7 of offset 16h in the EEPROM to 1. See Table 3–5, <i>EEPROM Loading Map</i> .
6–4	RSVD	R	Reserved. Bits 6–4 return 0s when read. These bits are affected when implementing a serial EEPROM; thus, bits 6–4 at EEPROM byte offset 16h must be programmed to 0. See Table 3–5, <i>EEPROM Loading Map</i> .
3	RSVD	R	Reserved. Bit 3 defaults to 1 to indicate compliance with IEEE Std 1394a-2000. If a serial EEPROM is implemented, then bit 3 at EEPROM byte offset 16h must be set to 1. See Table 3–5, <i>EEPROM Loading Map</i> .
2–0	RSVD	R	Reserved. Bits 2–0 return 0s when read. These bits are affected when implementing a serial EEPROM; thus, bits 2–0 at EEPROM byte offset 16h must be programmed to 0. See Table 3–5, <i>EEPROM Loading Map</i> .



## 7.24 Link Enhancement Control Register

The link enhancement control register implements TI proprietary bits that are initialized by software or by a serial EEPROM, if present. After these bits are set to 1, their functionality is enabled only if bit 22 (aPhyEnhanceEnable) in the host controller control register at OHCI offset 50h/54h (see Section 8.16) is set to 1. See Table 7–20 for a complete description of the register contents.

<b>Bit</b>	<b>31</b>	<b>30</b>	<b>29</b>	<b>28</b>	<b>27</b>	<b>26</b>	<b>25</b>	<b>24</b>	<b>23</b>	<b>22</b>	<b>21</b>	<b>20</b>	<b>19</b>	<b>18</b>	<b>17</b>	<b>16</b>
<b>Name</b>	Link enhancement control															
<b>Type</b>	R	R	R	R	R	R	R	R	R	R	R	R	R	R	R	R
<b>Default</b>	0	0	0	0	0	0	0	0	0	0	0	0	0	0	0	0
<b>Bit</b>	<b>15</b>	<b>14</b>	<b>13</b>	<b>12</b>	<b>11</b>	<b>10</b>	<b>9</b>	<b>8</b>	<b>7</b>	<b>6</b>	<b>5</b>	<b>4</b>	<b>3</b>	<b>2</b>	<b>1</b>	<b>0</b>
<b>Name</b>	Link enhancement control															
<b>Type</b>	RW	R	RW	RW	R	RW	R	RW	RW	R	R	R	R	R	RW	R
<b>Default</b>	0	0	0	1	0	0	0	0	0	0	0	0	0	0	0	0

Register: **Link enhancement control**

Offset: F4h

Type: Read/Write, Read-only

Default: 0000 1000h

**Table 7–20. Link Enhancement Control Register Description**

<b>BIT</b>	<b>FIELD NAME</b>	<b>TYPE</b>	<b>DESCRIPTION</b>
31–16	RSVD	R	Reserved. Bits 31–16 return 0s when read.
15	dis_at_pipeline	RW	Disable AT pipelining. When bit 15 is set to 1, out-of-order AT pipelining is disabled.
14	RSVD	R	Reserved.
13–12	atx_thresh	RW	<p>This field sets the initial AT threshold value, which is used until the AT FIFO is underrun. When the PCI4510 device retries the packet, it uses a 2K-byte threshold, resulting in a store-and-forward operation.</p> <p>00 = Threshold ~ 2K bytes resulting in a store-and-forward operation            01 = Threshold ~ 1.7K bytes (default)            10 = Threshold ~ 1K bytes            11 = Threshold ~ 512 bytes</p> <p>These bits fine-tune the asynchronous transmit threshold. For most applications the 1.7K-byte threshold is optimal. Changing this value may increase or decrease the 1394 latency depending on the average PCI bus latency.</p> <p>Setting the AT threshold to 1.7K, 1K, or 512 bytes results in data being transmitted at these thresholds or when an entire packet has been checked into the FIFO. If the packet to be transmitted is larger than the AT threshold, then the remaining data must be received before the AT FIFO is emptied; otherwise, an underrun condition occurs, resulting in a packet error at the receiving node. As a result, the link then commences store-and-forward operation. Wait until it has the complete packet in the FIFO before retransmitting it on the second attempt to ensure delivery.</p> <p>An AT threshold of 2K results in store-and-forward operation, which means that asynchronous data will not be transmitted until an end-of-packet token is received. Restated, setting the AT threshold to 2K results in only complete packets being transmitted.</p> <p>Note that this device will always use store-and-forward when the asynchronous transmit retries register at OHCI offset 08h (see Section 8.3) is cleared.</p>
11	RSVD	R	Reserved. Bit 11 returns 0 when read.
10	enab_mpeg_ts	RW	Enable MPEG CIP timestamp enhancement. When bit 9 is set to 1, the enhancement is enabled for MPEG CIP transmit streams (FMT = 20h).
9	RSVD	R	Reserved. Bit 9 returns 0 when read.
8	enab_dv_ts	RW	Enable DV CIP timestamp enhancement. When bit 8 is set to 1, the enhancement is enabled for DV CIP transmit streams (FMT = 00h).
7	enab_unfair	RW	Enable asynchronous priority requests. OHCI-Lynx™ compatible. Setting bit 7 to 1 enables the link to respond to requests with priority arbitration. It is recommended that this bit be set to 1.

**Table 7–20. Link Enhancement Control Register Description (Continued)**

BIT	FIELD NAME	TYPE	DESCRIPTION
6	RSVD	R	This bit is not assigned in the PCI4510 follow-on products, because this bit location loaded by the serial EEPROM from the enhancements field corresponds to bit 23 (programPhyEnable) in the host controller control register at OHCI offset 50h/54h (see Section 8.16).
5–2	RSVD	R	Reserved. Bits 5–2 return 0s when read.
1	enab_accel	RW	Enable acceleration enhancements. OHCI-Lynx™ compatible. When bit 1 is set to 1, the PHY layer is notified that the link supports the IEEE Std 1394a-2000 acceleration enhancements, that is, ack-accelerated, fly-by concatenation, etc. It is recommended that this bit be set to 1.
0	RSVD	R	Reserved. Bit 0 returns 0 when read.

## 7.25 Subsystem Access Register

Write access to the subsystem access register updates the subsystem identification registers identically to OHCI-Lynx™. The system ID value written to this register may also be read back from this register. See Table 7–21 for a complete description of the register contents.

Bit	31	30	29	28	27	26	25	24	23	22	21	20	19	18	17	16
<b>Name</b>	Subsystem access															
<b>Type</b>	RW	RW	RW	RW	RW	RW	RW	RW	RW	RW	RW	RW	RW	RW	RW	RW
<b>Default</b>	0	0	0	0	0	0	0	0	0	0	0	0	0	0	0	0
Bit	15	14	13	12	11	10	9	8	7	6	5	4	3	2	1	0
<b>Name</b>	Subsystem access															
<b>Type</b>	RW	RW	RW	RW	RW	RW	RW	RW	RW	RW	RW	RW	RW	RW	RW	RW
<b>Default</b>	0	0	0	0	0	0	0	0	0	0	0	0	0	0	0	0

Register: **Subsystem access**  
 Offset: F8h  
 Type: Read/Write  
 Default: 0000 0000h

**Table 7–21. Subsystem Access Register Description**

BIT	FIELD NAME	TYPE	DESCRIPTION
31–16	SUBDEV_ID	RW	Subsystem device ID alias. This field indicates the subsystem device ID.
15–0	SUBVEN_ID	RW	Subsystem vendor ID alias. This field indicates the subsystem vendor ID.



## 8 OHCI Registers

The OHCI registers defined by the *1394 Open Host Controller Interface Specification* are memory-mapped into a 2K-byte region of memory pointed to by the OHCI base address register at offset 10h in PCI configuration space (see Section 7.8). These registers are the primary interface for controlling the PCI4510 IEEE 1394 link function.

This section provides the register interface and bit descriptions. Several set/clear register pairs in this programming model are implemented to solve various issues with typical read-modify-write control registers. There are two addresses for a set/clear register: RegisterSet and RegisterClear. See Table 8–1 for a register listing. A 1 bit written to RegisterSet causes the corresponding bit in the set/clear register to be set to 1; a 0 bit leaves the corresponding bit unaffected. A 1 bit written to RegisterClear causes the corresponding bit in the set/clear register to be cleared; a 0 bit leaves the corresponding bit in the set/clear register unaffected.

Typically, a read from either RegisterSet or RegisterClear returns the contents of the set or clear register, respectively. However, sometimes reading the RegisterClear provides a masked version of the set or clear register. The interrupt event register is an example of this behavior.

**Table 8–1. OHCI Register Map**

DMA CONTEXT	REGISTER NAME	ABBREVIATION	OFFSET	
—	OHCI version	Version	00h	
	GUID ROM	GUID_ROM	04h	
	Asynchronous transmit retries	ATRetries	08h	
	CSR data	CSRData	0Ch	
	CSR compare	CSRCompareData	10h	
	CSR control	CSRControl	14h	
	Configuration ROM header	ConfigROMhdr	18h	
	Bus identification	BusID	1Ch	
	Bus options	BusOptions	20h	
	GUID high	GUIDHi	24h	
	GUID low	GUIDLo	28h	
	Reserved	—	2Ch–30h	
	Configuration ROM mapping	ConfigROMmap	34h	
	Posted write address low	PostedWriteAddressLo	38h	
	Posted write address high	PostedWriteAddressHi	3Ch	
	Vendor ID	VendorID	40h	
	Reserved	—	44h–4Ch	
	Host controller control	HCControlSet		50h
		HCControlClr		54h
	Reserved	—	58h–5Ch	

**Table 8–1. OHCI Register Map (Continued)**

DMA CONTEXT	REGISTER NAME	ABBREVIATION	OFFSET	
Self-ID	Reserved	—	60h	
	Self-ID buffer pointer	SelfIDBuffer	64h	
	Self-ID count	SelfIDCount	68h	
	Reserved	—	6Ch	
—	Isochronous receive channel mask high	IRChannelMaskHiSet	70h	
		IRChannelMaskHiClear	74h	
	Isochronous receive channel mask low	IRChannelMaskLoSet	78h	
		IRChannelMaskLoClear	7Ch	
	Interrupt event	IntEventSet	80h	
		IntEventClear	84h	
	Interrupt mask	IntMaskSet	88h	
		IntMaskClear	8Ch	
	Isochronous transmit interrupt event	IsoXmitIntEventSet	90h	
		IsoXmitIntEventClear	94h	
	Isochronous transmit interrupt mask	IsoXmitIntMaskSet	98h	
		IsoXmitIntMaskClear	9Ch	
	—	Isochronous receive interrupt event	IsoRecvIntEventSet	A0h
			IsoRecvIntEventClear	A4h
Isochronous receive interrupt mask		IsoRecvIntMaskSet	A8h	
		IsoRecvIntMaskClear	ACh	
Initial bandwidth available		InitialBandwidthAvailable	B0h	
Initial channels available high		InitialChannelsAvailableHi	B4h	
Initial channels available low		InitialChannelsAvailableLo	B8h	
Reserved		—	BCh–D8h	
Fairness control		FairnessControl	DCh	
Link control		LinkControlSet	E0h	
		LinkControlClear	E4h	
Node identification		NodeID	E8h	
PHY layer control		PhyControl	ECh	
Isochronous cycle timer		Isocyc timer	F0h	
Reserved		—	F4h–FCh	
Asynchronous request filter high		AsyncRequestFilterHiSet	100h	
		AsyncRequestFilterHiClear	104h	
Asynchronous request filter low		AsyncRequestFilterLoSet	108h	
		AsyncRequestFilterLoClear	10Ch	
Physical request filter high		PhysicalRequestFilterHiSet	110h	
		PhysicalRequestFilterHiClear	114h	
Physical request filter low		PhysicalRequestFilterLoSet	118h	
	PhysicalRequestFilterLoClear	11Ch		
Physical upper bound	PhysicalUpperBound	120h		
Reserved	—	124h–17Ch		



**Table 8–1. OHCI Register Map (Continued)**

DMA CONTEXT	REGISTER NAME	ABBREVIATION	OFFSET
Asynchronous Request Transmit [ ATRQ ]	Asynchronous context control	ContextControlSet	180h
		ContextControlClear	184h
	Reserved	—	188h
	Asynchronous context command pointer	CommandPtr	18Ch
	Reserved	—	190h–19Ch
Asynchronous Response Transmit [ ATRS ]	Asynchronous context control	ContextControlSet	1A0h
		ContextControlClear	1A4h
	Reserved	—	1A8h
	Asynchronous context command pointer	CommandPtr	1ACh
	Reserved	—	1B0h–1BCh
Asynchronous Request Receive [ ARRQ ]	Asynchronous context control	ContextControlSet	1C0h
		ContextControlClear	1C4h
	Reserved	—	1C8h
	Asynchronous context command pointer	CommandPtr	1CCh
	Reserved	—	1D0h–1DCh
Asynchronous Response Receive [ ARRS ]	Asynchronous context control	ContextControlSet	1E0h
		ContextControlClear	1E4h
	Reserved	—	1E8h
	Asynchronous context command pointer	CommandPtr	1ECh
	Reserved	—	1F0h–1FCh
Isochronous Transmit Context n n = 0, 1, 2, 3, ..., 7	Isochronous transmit context control	ContextControlSet	200h + 16*n
		ContextControlClear	204h + 16*n
	Reserved	—	208h + 16*n
	Isochronous transmit context command pointer	CommandPtr	20Ch + 16*n
	Reserved	—	210h–3FCh
Isochronous Receive Context n n = 0, 1, 2, 3	Isochronous receive context control	ContextControlSet	400h + 32*n
		ContextControlClear	404h + 32*n
	Reserved	—	408h + 32*n
	Isochronous receive context command pointer	CommandPtr	40Ch + 32*n
	Isochronous receive context match	ContextMatch	410h + 32*n

## 8.1 OHCI Version Register

The OHCI version register indicates the OHCI version support and whether or not the serial EEPROM is present. See Table 8–2 for a complete description of the register contents.

Bit	31	30	29	28	27	26	25	24	23	22	21	20	19	18	17	16
Name	OHCI version															
Type	R	R	R	R	R	R	R	R	R	R	R	R	R	R	R	R
Default	0	0	0	0	0	0	0	X	0	0	0	0	0	0	0	1
Bit	15	14	13	12	11	10	9	8	7	6	5	4	3	2	1	0
Name	OHCI version															
Type	R	R	R	R	R	R	R	R	R	R	R	R	R	R	R	R
Default	0	0	0	0	0	0	0	0	0	0	0	1	0	0	0	0

Register: **OHCI version**  
 Offset: 00h  
 Type: Read-only  
 Default: 0X01 0010h

**Table 8–2. OHCI Version Register Description**

BIT	FIELD NAME	TYPE	DESCRIPTION
31–25	RSVD	R	Reserved. Bits 31–25 return 0s when read.
24	GUID_ROM	R	The PCI4510 device sets bit 24 to 1 if the serial EEPROM is detected. If the serial EEPROM is present, then the Bus_Info_Block is automatically loaded on system (hardware) reset.
23–16	version	R	Major version of the OHCI. The PCI4510 device is compliant with the <i>1394 Open Host Controller Interface Specification</i> (Release 1.1); thus, this field reads 01h.
15–8	RSVD	R	Reserved. Bits 15–8 return 0s when read.
7–0	revision	R	Minor version of the OHCI. The PCI4510 device is compliant with the <i>1394 Open Host Controller Interface Specification</i> (Release 1.1); thus, this field reads 10h.

## 8.2 GUID ROM Register

The GUID ROM register accesses the serial EEPROM, and is only applicable if bit 24 (GUID\_ROM) in the OHCI version register at OHCI offset 00h (see Section 8.1) is set to 1. See Table 8–3 for a complete description of the register contents.

Bit	31	30	29	28	27	26	25	24	23	22	21	20	19	18	17	16
Name	GUID ROM															
Type	RSU	R	R	R	R	R	RSU	R	RU	RU	RU	RU	RU	RU	RU	RU
Default	0	0	0	0	0	0	0	0	X	X	X	X	X	X	X	X
Bit	15	14	13	12	11	10	9	8	7	6	5	4	3	2	1	0
Name	GUID ROM															
Type	R	R	R	R	R	R	R	R	R	R	R	R	R	R	R	R
Default	0	0	0	0	0	0	0	0	0	0	0	0	0	0	0	0

Register: **GUID ROM**  
 Offset: 04h  
 Type: Read/Set/Update, Read/Update, Read-only  
 Default: 00XX 0000h

**Table 8–3. GUID ROM Register Description**

BIT	FIELD NAME	TYPE	DESCRIPTION
31	addrReset	RSU	Software sets bit 31 to 1 to reset the GUID ROM address to 0. When the PCI4510 device completes the reset, it clears this bit. The PCI4510 device does not automatically fill bits 23–16 (rdData field) with the 0 <sup>th</sup> byte.
30–26	RSVD	R	Reserved. Bits 30–26 return 0s when read.
25	rdStart	RSU	A read of the currently addressed byte is started when bit 25 is set to 1. This bit is automatically cleared when the PCI4510 device completes the read of the currently addressed GUID ROM byte.
24	RSVD	R	Reserved. Bit 24 returns 0 when read.
23–16	rdData	RU	This field contains the data read from the GUID ROM.
15–8	RSVD	R	Reserved. Bits 15–8 return 0s when read.
7–0	miniROM	R	The miniROM field defaults to 0 indicating that no mini-ROM is implemented. If bit 5 of EEPROM offset 6h is set to 1, then this field returns 20h indicating that valid mini-ROM data begins at offset 20h of the GUID ROM.

### 8.3 Asynchronous Transmit Retries Register

The asynchronous transmit retries register indicates the number of times the PCI4510 device attempts a retry for asynchronous DMA request transmit and for asynchronous physical and DMA response transmit. See Table 8–4 for a complete description of the register contents.

Bit	31	30	29	28	27	26	25	24	23	22	21	20	19	18	17	16
Name	Asynchronous transmit retries															
Type	R	R	R	R	R	R	R	R	R	R	R	R	R	R	R	R
Default	0	0	0	0	0	0	0	0	0	0	0	0	0	0	0	0
Bit	15	14	13	12	11	10	9	8	7	6	5	4	3	2	1	0
Name	Asynchronous transmit retries															
Type	R	R	R	R	RW	RW	RW	RW	RW	RW	RW	RW	RW	RW	RW	RW
Default	0	0	0	0	0	0	0	0	0	0	0	0	0	0	0	0

Register: **Asynchronous transmit retries**  
 Offset: 08h  
 Type: Read/Write, Read-only  
 Default: 0000 0000h

**Table 8–4. Asynchronous Transmit Retries Register Description**

BIT	FIELD NAME	TYPE	DESCRIPTION
31–29	secondLimit	R	The second limit field returns 0s when read, because outbound dual-phase retry is not implemented.
28–16	cycleLimit	R	The cycle limit field returns 0s when read, because outbound dual-phase retry is not implemented.
15–12	RSVD	R	Reserved. Bits 15–12 return 0s when read.
11–8	maxPhysRespRetries	RW	This field tells the physical response unit how many times to attempt to retry the transmit operation for the response packet when a busy acknowledge or ack_data_error is received from the target node.
7–4	maxATRespRetries	RW	This field tells the asynchronous transmit response unit how many times to attempt to retry the transmit operation for the response packet when a busy acknowledge or ack_data_error is received from the target node.
3–0	maxATReqRetries	RW	This field tells the asynchronous transmit DMA request unit how many times to attempt to retry the transmit operation for the response packet when a busy acknowledge or ack_data_error is received from the target node.

### 8.4 CSR Data Register

The CSR data register accesses the bus management CSR registers from the host through compare-swap operations. This register contains the data to be stored in a CSR if the compare is successful.

Bit	31	30	29	28	27	26	25	24	23	22	21	20	19	18	17	16
Name	CSR data															
Type	R	R	R	R	R	R	R	R	R	R	R	R	R	R	R	R
Default	X	X	X	X	X	X	X	X	X	X	X	X	X	X	X	X
Bit	15	14	13	12	11	10	9	8	7	6	5	4	3	2	1	0
Name	CSR data															
Type	R	R	R	R	R	R	R	R	R	R	R	R	R	R	R	R
Default	X	X	X	X	X	X	X	X	X	X	X	X	X	X	X	X

Register: **CSR data**  
 Offset: 0Ch  
 Type: Read-only  
 Default: XXXX XXXXh

## 8.5 CSR Compare Register

The CSR compare register accesses the bus management CSR registers from the host through compare-swap operations. This register contains the data to be compared with the existing value of the CSR resource.

Bit	31	30	29	28	27	26	25	24	23	22	21	20	19	18	17	16
Name	CSR compare															
Type	R	R	R	R	R	R	R	R	R	R	R	R	R	R	R	R
Default	X	X	X	X	X	X	X	X	X	X	X	X	X	X	X	X
Bit	15	14	13	12	11	10	9	8	7	6	5	4	3	2	1	0
Name	CSR compare															
Type	R	R	R	R	R	R	R	R	R	R	R	R	R	R	R	R
Default	X	X	X	X	X	X	X	X	X	X	X	X	X	X	X	X

Register: **CSR compare**  
 Offset: 10h  
 Type: Read-only  
 Default: XXXX XXXXh

## 8.6 CSR Control Register

The CSR control register accesses the bus management CSR registers from the host through compare-swap operations. This register controls the compare-swap operation and selects the CSR resource. See Table 8–5 for a complete description of the register contents.

Bit	31	30	29	28	27	26	25	24	23	22	21	20	19	18	17	16
Name	CSR control															
Type	RU	R	R	R	R	R	R	R	R	R	R	R	R	R	R	R
Default	1	0	0	0	0	0	0	0	0	0	0	0	0	0	0	0
Bit	15	14	13	12	11	10	9	8	7	6	5	4	3	2	1	0
Name	CSR control															
Type	R	R	R	R	R	R	R	R	R	R	R	R	R	R	RW	RW
Default	0	0	0	0	0	0	0	0	0	0	0	0	0	0	X	X

Register: **CSR control**  
 Offset: 14h  
 Type: Read/Write, Read/Update, Read-only  
 Default: 8000 000Xh

**Table 8–5. CSR Control Register Description**

BIT	FIELD NAME	TYPE	DESCRIPTION
31	csrDone	RU	Bit 31 is set to 1 by the PCI4510 device when a compare-swap operation is complete. It is cleared whenever this register is written.
30–2	RSVD	R	Reserved. Bits 30–2 return 0s when read.
1–0	csrSel	RW	This field selects the CSR resource as follows: 00 = BUS_MANAGER_ID 01 = BANDWIDTH_AVAILABLE 10 = CHANNELS_AVAILABLE_HI 11 = CHANNELS_AVAILABLE_LO

## 8.7 Configuration ROM Header Register

The configuration ROM header register externally maps to the first quadlet of the 1394 configuration ROM, offset FFFF F000 0400h. See Table 8–6 for a complete description of the register contents.

Bit	31	30	29	28	27	26	25	24	23	22	21	20	19	18	17	16
<b>Name</b>	Configuration ROM header															
<b>Type</b>	RW	RW	RW	RW	RW	RW	RW	RW	RW	RW	RW	RW	RW	RW	RW	RW
<b>Default</b>	0	0	0	0	0	0	0	0	0	0	0	0	0	0	0	0
Bit	15	14	13	12	11	10	9	8	7	6	5	4	3	2	1	0
<b>Name</b>	Configuration ROM header															
<b>Type</b>	RW	RW	RW	RW	RW	RW	RW	RW	RW	RW	RW	RW	RW	RW	RW	RW
<b>Default</b>	X	X	X	X	X	X	X	X	X	X	X	X	X	X	X	X

Register: **Configuration ROM header**  
 Offset: 18h  
 Type: Read/Write  
 Default: 0000 XXXXh

**Table 8–6. Configuration ROM Header Register Description**

BIT	FIELD NAME	TYPE	DESCRIPTION
31–24	info_length	RW	IEEE 1394 bus-management field. Must be valid when bit 17 (linkEnable) in the host controller control register at OHCI offset 50h/54h (see Section 8.16) is set to 1.
23–16	crc_length	RW	IEEE 1394 bus-management field. Must be valid when bit 17 (linkEnable) in the host controller control register at OHCI offset 50h/54h (see Section 8.16) is set to 1.
15–0	rom_crc_value	RW	IEEE 1394 bus-management field. Must be valid at any time bit 17 (linkEnable) in the host controller control register at OHCI offset 50h/54h (see Section 8.16) is set to 1. The reset value is undefined if no serial EEPROM is present. If a serial EEPROM is present, then this field is loaded from the serial EEPROM.

## 8.8 Bus Identification Register

The bus identification register externally maps to the first quadlet in the Bus\_Info\_Block and contains the constant 3133 3934h, which is the ASCII value of 1394.

Bit	31	30	29	28	27	26	25	24	23	22	21	20	19	18	17	16
<b>Name</b>	Bus identification															
<b>Type</b>	R	R	R	R	R	R	R	R	R	R	R	R	R	R	R	R
<b>Default</b>	0	0	1	1	0	0	0	1	0	0	1	1	0	0	1	1
Bit	15	14	13	12	11	10	9	8	7	6	5	4	3	2	1	0
<b>Name</b>	Bus identification															
<b>Type</b>	R	R	R	R	R	R	R	R	R	R	R	R	R	R	R	R
<b>Default</b>	0	0	1	1	1	0	0	1	0	0	1	1	0	1	0	0

Register: **Bus identification**  
 Offset: 1Ch  
 Type: Read-only  
 Default: 3133 3934h

## 8.9 Bus Options Register

The bus options register externally maps to the second quadlet of the Bus\_Info\_Block. See Table 8–7 for a complete description of the register contents.

Bit	31	30	29	28	27	26	25	24	23	22	21	20	19	18	17	16
<b>Name</b>	Bus options															
<b>Type</b>	RW	RW	RW	RW	RW	R	R	R	RW	RW	RW	RW	RW	RW	RW	RW
<b>Default</b>	X	X	X	X	0	0	0	0	X	X	X	X	X	X	X	X
Bit	15	14	13	12	11	10	9	8	7	6	5	4	3	2	1	0
<b>Name</b>	Bus options															
<b>Type</b>	RW	RW	RW	RW	R	R	R	R	RW	RW	R	R	R	R	R	R
<b>Default</b>	1	0	1	0	0	0	0	0	X	X	0	0	0	0	1	0

Register: **Bus options**  
 Offset: 20h  
 Type: Read/Write, Read-only  
 Default: X0XX A0X2h

**Table 8–7. Bus Options Register Description**

BIT	FIELD NAME	TYPE	DESCRIPTION
31	irmc	RW	Isosynchronous resource-manager capable. IEEE 1394 bus-management field. Must be valid when bit 17 (linkEnable) in the host controller control register at OHCI offset 50h/54h (see Section 8.16) is set to 1.
30	cmc	RW	Cycle master capable. IEEE 1394 bus-management field. Must be valid when bit 17 (linkEnable) in the host controller control register at OHCI offset 50h/54h (see Section 8.16) is set to 1.
29	isc	RW	Isosynchronous support capable. IEEE 1394 bus-management field. Must be valid when bit 17 (linkEnable) in the host controller control register at OHCI offset 50h/54h (see Section 8.16) is set to 1.
28	bmc	RW	Bus manager capable. IEEE 1394 bus-management field. Must be valid when bit 17 (linkEnable) in the host controller control register at OHCI offset 50h/54h (see Section 8.16) is set to 1.
27	pmc	RW	Power-management capable. IEEE 1394 bus-management field. When bit 27 is set to 1, this indicates that the node is power-management capable. Must be valid when bit 17 (linkEnable) in the host controller control register at OHCI offset 50h/54h (see Section 8.16) is set to 1.
26–24	RSVD	R	Reserved. Bits 26–24 return 0s when read.
23–16	cyc_clk_acc	RW	Cycle master clock accuracy, in parts per million. IEEE 1394 bus-management field. Must be valid when bit 17 (linkEnable) in the host controller control register at OHCI offset 50h/54h (see Section 8.16) is set to 1.
15–12	max_rec	RW	Maximum request. IEEE 1394 bus-management field. Hardware initializes this field to indicate the maximum number of bytes in a block request packet that is supported by the implementation. This value, max_rec_bytes, must be 512 or greater, and is calculated by $2^{(\text{max\_rec} + 1)}$ . Software may change this field; however, this field must be valid at any time bit 17 (linkEnable) in the host controller control register at OHCI offset 50h/54h (see Section 8.16) is set to 1. A received block write request packet with a length greater than max_rec_bytes may generate an ack_type_error. This field is not affected by a software reset, and defaults to value indicating 2048 bytes on a system (hardware) reset.
11–8	RSVD	R	Reserved. Bits 11–8 return 0s when read.
7–6	g	RW	Generation counter. This field is incremented if any portion of the configuration ROM has been incremented since the prior bus reset.
5–3	RSVD	R	Reserved. Bits 5–3 return 0s when read.
2–0	Lnk_spd	R	Link speed. This field returns 010, indicating that the link speeds of 100M bits/s, 200M bits/s, and 400M bits/s are supported.

## 8.10 GUID High Register

The GUID high register represents the upper quadlet in a 64-bit global unique ID (GUID) which maps to the third quadlet in the Bus\_Info\_Block. This register contains node\_vendor\_ID and chip\_ID\_hi fields. This register initializes to 0s on a system (hardware) reset, which is an illegal GUID value. If a serial EEPROM is detected, then the contents of this register are loaded through the serial EEPROM interface after a PRST. At that point, the contents of this register cannot be changed. If no serial EEPROM is detected, then the contents of this register are loaded by the BIOS after a PRST. At that point, the contents of this register cannot be changed.

<b>Bit</b>	<b>31</b>	<b>30</b>	<b>29</b>	<b>28</b>	<b>27</b>	<b>26</b>	<b>25</b>	<b>24</b>	<b>23</b>	<b>22</b>	<b>21</b>	<b>20</b>	<b>19</b>	<b>18</b>	<b>17</b>	<b>16</b>
<b>Name</b>	GUID high															
<b>Type</b>	R	R	R	R	R	R	R	R	R	R	R	R	R	R	R	R
<b>Default</b>	0	0	0	0	0	0	0	0	0	0	0	0	0	0	0	0
<b>Bit</b>	<b>15</b>	<b>14</b>	<b>13</b>	<b>12</b>	<b>11</b>	<b>10</b>	<b>9</b>	<b>8</b>	<b>7</b>	<b>6</b>	<b>5</b>	<b>4</b>	<b>3</b>	<b>2</b>	<b>1</b>	<b>0</b>
<b>Name</b>	GUID high															
<b>Type</b>	R	R	R	R	R	R	R	R	R	R	R	R	R	R	R	R
<b>Default</b>	0	0	0	0	0	0	0	0	0	0	0	0	0	0	0	0

Register: **GUID high**  
 Offset: 24h  
 Type: Read-only  
 Default: 0000 0000h

## 8.11 GUID Low Register

The GUID low register represents the lower quadlet in a 64-bit global unique ID (GUID) which maps to chip\_ID\_lo in the Bus\_Info\_Block. This register initializes to 0s on a system (hardware) reset and behaves identical to the GUID high register at OHCI offset 24h (see Section 8.10).

<b>Bit</b>	<b>31</b>	<b>30</b>	<b>29</b>	<b>28</b>	<b>27</b>	<b>26</b>	<b>25</b>	<b>24</b>	<b>23</b>	<b>22</b>	<b>21</b>	<b>20</b>	<b>19</b>	<b>18</b>	<b>17</b>	<b>16</b>
<b>Name</b>	GUID low															
<b>Type</b>	R	R	R	R	R	R	R	R	R	R	R	R	R	R	R	R
<b>Default</b>	0	0	0	0	0	0	0	0	0	0	0	0	0	0	0	0
<b>Bit</b>	<b>15</b>	<b>14</b>	<b>13</b>	<b>12</b>	<b>11</b>	<b>10</b>	<b>9</b>	<b>8</b>	<b>7</b>	<b>6</b>	<b>5</b>	<b>4</b>	<b>3</b>	<b>2</b>	<b>1</b>	<b>0</b>
<b>Name</b>	GUID low															
<b>Type</b>	R	R	R	R	R	R	R	R	R	R	R	R	R	R	R	R
<b>Default</b>	0	0	0	0	0	0	0	0	0	0	0	0	0	0	0	0

Register: **GUID low**  
 Offset: 28h  
 Type: Read-only  
 Default: 0000 0000h



## 8.12 Configuration ROM Mapping Register

The configuration ROM mapping register contains the start address within system memory that maps to the start address of 1394 configuration ROM for this node. See Table 8–8 for a complete description of the register contents.

Bit	31	30	29	28	27	26	25	24	23	22	21	20	19	18	17	16
<b>Name</b>	Configuration ROM mapping															
<b>Type</b>	RW	RW	RW	RW	RW	RW	RW	RW	RW	RW	RW	RW	RW	RW	RW	RW
<b>Default</b>	0	0	0	0	0	0	0	0	0	0	0	0	0	0	0	0
Bit	15	14	13	12	11	10	9	8	7	6	5	4	3	2	1	0
<b>Name</b>	Configuration ROM mapping															
<b>Type</b>	RW	RW	RW	RW	RW	RW	R	R	R	R	R	R	R	R	R	R
<b>Default</b>	0	0	0	0	0	0	0	0	0	0	0	0	0	0	0	0

Register: **Configuration ROM mapping**  
 Offset: 34h  
 Type: Read/Write  
 Default: 0000 0000h

**Table 8–8. Configuration ROM Mapping Register Description**

BIT	FIELD NAME	TYPE	DESCRIPTION
31–10	configROMAddr	RW	If a quadlet read request to 1394 offset FFFF F000 0400h through offset FFFF F000 07FFh is received, then the low-order 10 bits of the offset are added to this register to determine the host memory address of the read request.
9–0	RSVD	R	Reserved. Bits 9–0 return 0s when read.

## 8.13 Posted Write Address Low Register

The posted write address low register communicates error information if a write request is posted and an error occurs while the posted data packet is being written. See Table 8–9 for a complete description of the register contents.

Bit	31	30	29	28	27	26	25	24	23	22	21	20	19	18	17	16
<b>Name</b>	Posted write address low															
<b>Type</b>	RU	RU	RU	RU	RU	RU	RU	RU	RU	RU	RU	RU	RU	RU	RU	RU
<b>Default</b>	X	X	X	X	X	X	X	X	X	X	X	X	X	X	X	X
Bit	15	14	13	12	11	10	9	8	7	6	5	4	3	2	1	0
<b>Name</b>	Posted write address low															
<b>Type</b>	RU	RU	RU	RU	RU	RU	RU	RU	RU	RU	RU	RU	RU	RU	RU	RU
<b>Default</b>	X	X	X	X	X	X	X	X	X	X	X	X	X	X	X	X

Register: **Posted write address low**  
 Offset: 38h  
 Type: Read/Update  
 Default: XXXX XXXXh

**Table 8–9. Posted Write Address Low Register Description**

BIT	FIELD NAME	TYPE	DESCRIPTION
31–0	offsetLo	RU	The lower 32 bits of the 1394 destination offset of the write request that failed.

## 8.14 Posted Write Address High Register

The posted write address high register communicates error information if a write request is posted and an error occurs while writing the posted data packet. See Table 8–10 for a complete description of the register contents.

Bit	31	30	29	28	27	26	25	24	23	22	21	20	19	18	17	16
<b>Name</b>	Posted write address high															
<b>Type</b>	RU	RU	RU	RU	RU	RU	RU	RU	RU	RU	RU	RU	RU	RU	RU	RU
<b>Default</b>	X	X	X	X	X	X	X	X	X	X	X	X	X	X	X	X
Bit	15	14	13	12	11	10	9	8	7	6	5	4	3	2	1	0
<b>Name</b>	Posted write address high															
<b>Type</b>	RU	RU	RU	RU	RU	RU	RU	RU	RU	RU	RU	RU	RU	RU	RU	RU
<b>Default</b>	X	X	X	X	X	X	X	X	X	X	X	X	X	X	X	X

Register: **Posted write address high**  
 Offset: 3Ch  
 Type: Read/Update  
 Default: XXXX XXXXh

**Table 8–10. Posted Write Address High Register Description**

BIT	FIELD NAME	TYPE	DESCRIPTION
31–16	sourceID	RU	This field is the 10-bit bus number (bits 31–22) and 6-bit node number (bits 21–16) of the node that issued the write request that failed.
15–0	offsetHi	RU	The upper 16 bits of the 1394 destination offset of the write request that failed.

## 8.15 Vendor ID Register

The vendor ID register holds the company ID of an organization that specifies any vendor-unique registers. The PCI4510 device implements Texas Instruments unique behavior with regards to OHCI. Thus, this register is read-only and returns 0108 0028h when read.

Bit	31	30	29	28	27	26	25	24	23	22	21	20	19	18	17	16
<b>Name</b>	Vendor ID															
<b>Type</b>	R	R	R	R	R	R	R	R	R	R	R	R	R	R	R	R
<b>Default</b>	0	0	0	0	0	0	0	1	0	0	0	0	1	0	0	0
Bit	15	14	13	12	11	10	9	8	7	6	5	4	3	2	1	0
<b>Name</b>	Vendor ID															
<b>Type</b>	R	R	R	R	R	R	R	R	R	R	R	R	R	R	R	R
<b>Default</b>	0	0	0	0	0	0	0	0	0	0	1	0	1	0	0	0

Register: **Vendor ID**  
 Offset: 40h  
 Type: Read-only  
 Default: 0108 0028h

## 8.16 Host Controller Control Register

The host controller control set/clear register pair provides flags for controlling the PCI4510 device. See Table 8–11 for a complete description of the register contents.

Bit	31	30	29	28	27	26	25	24	23	22	21	20	19	18	17	16
<b>Name</b>	Host controller control															
<b>Type</b>	RSU	RSC	RSC	R	R	R	R	R	R	RSC	R	R	RSC	RSC	RSC	RSCU
<b>Default</b>	0	X	0	0	0	0	0	0	1	0	0	0	0	X	0	0

Bit	15	14	13	12	11	10	9	8	7	6	5	4	3	2	1	0
<b>Name</b>	Host controller control															
<b>Type</b>	R	R	R	R	R	R	R	R	R	R	R	R	R	R	R	R
<b>Default</b>	0	0	0	0	0	0	0	0	0	0	0	0	0	0	0	0

Register: **Host controller control**  
 Offset: 50h set register  
 54h clear register  
 Type: Read/Set/Clear/Update, Read/Set/Clear, Read/Clear, Read-only  
 Default: X08X 0000h

**Table 8–11. Host Controller Control Register Description**

BIT	FIELD NAME	TYPE	DESCRIPTION
31	BIBimage Valid	RSU	<p>When bit 31 is set to 1, the PCI4510 physical response unit is enabled to respond to block read requests to host configuration ROM and to the mechanism for atomically updating configuration ROM. Software creates a valid image of the bus_info_block in host configuration ROM before setting this bit.</p> <p>When this bit is cleared, the PCI4510 device returns ack_type_error on block read requests to host configuration ROM. Also, when this bit is cleared and a 1394 bus reset occurs, the configuration ROM mapping register at OHCI offset 34h (see Section 8.12), configuration ROM header register at OHCI offset 18h (see Section 8.7), and bus options register at OHCI offset 20h (see Section 8.9) are not updated.</p> <p>Software can set this bit only when bit 17 (linkEnable) is 0. Once bit 31 is set to 1, it can be cleared by a system (hardware) reset, a software reset, or if a fetch error occurs when the PCI4510 device loads bus_info_block registers from host memory.</p>
30	noByteSwapData	RSC	Bit 30 controls whether physical accesses to locations outside the PCI4510 device itself, as well as any other DMA data accesses are byte swapped.
29	AckTardyEnable	RSC	<p>Bit 29 controls the acknowledgement of ack_tardy. When bit 29 is set to 1, ack_tardy may be returned as an acknowledgment to accesses from the 1394 bus to the PCI4510 device, including accesses to the bus_info_block. The PCI4510 device returns ack_tardy to all other asynchronous packets addressed to the PCI4510 node. When the PCI4510 device sends ack_tardy, bit 27 (ack_tardy) in the interrupt event register at OHCI offset 80h/84h (see Section 8.21) is set to 1 to indicate the attempted asynchronous access.</p> <p>Software ensures that bit 27 (ack_tardy) in the interrupt event register is 0. Software also unmarks wake-up interrupt events such as bit 19 (phy) and bit 27 (ack_tardy) in the interrupt event register before placing the PCI4510 device into the D1 power mode.</p> <p>Software must not set this bit if the PCI4510 node is the 1394 bus manager.</p>
28–24	RSVD	R	Reserved. Bits 28–24 return 0s when read.
23	programPhyEnable	R	Bit 23 informs upper-level software that lower-level software has consistently configured the IEEE 1394a-2000 enhancements in the link and PHY layers. When this bit is 1, generic software such as the OHCI driver is responsible for configuring IEEE 1394a-2000 enhancements in the PHY layer and bit 22 (aPhyEnhanceEnable). When this bit is 0, the generic software may not modify the IEEE 1394a-2000 enhancements in the PHY layer and cannot interpret the setting of bit 22 (aPhyEnhanceEnable). This bit is initialized from serial EEPROM. This bit defaults to 1.

**Table 8–11. Host Controller Control Register Description (Continued)**

BIT	FIELD NAME	TYPE	DESCRIPTION
22	aPhyEnhanceEnable	RSC	When bits 23 (programPhyEnable) and 17 (linkEnable) are 1, the OHCI driver can set bit 22 to 1 to use all IEEE 1394a-2000 enhancements. When bit 23 (programPhyEnable) is cleared to 0, the software does not change PHY enhancements or this bit.
21–20	RSVD	R	Reserved. Bits 21 and 20 return 0s when read.
19	LPS	RSC	Bit 19 controls the link power status. Software must set this bit to 1 to permit the link-PHY communication. A 0 prevents link-PHY communication.  The OHCI-link is divided into two clock domains (PCLK and PHY_SCLK). If software tries to access any register in the PHY_SCLK domain while the PHY_SCLK is disabled, then a target abort is issued by the link. This problem can be avoided by setting bit 4 (DIS_TGT_ABT) to 1 in the miscellaneous configuration register at offset F0h in the PCI configuration space (see Section 7.23). This allows the link to respond to these types of request by returning all Fs (hex).  OHCI registers at offsets DCh–F0h and 100h–11Ch are in the PHY_SCLK domain.  After setting LPS, software must wait approximately 10 ms before attempting to access any of the OHCI registers. This gives the PHY_SCLK time to stabilize.
18	postedWriteEnable	RSC	Bit 18 enables (1) or disables (0) posted writes. Software changes this bit only when bit 17 (linkEnable) is 0.
17	linkEnable	RSC	Bit 17 is cleared to 0 by either a system (hardware) or software reset. Software must set this bit to 1 when the system is ready to begin operation and then force a bus reset. This bit is necessary to keep other nodes from sending transactions before the local system is ready. When this bit is cleared, the PCI4510 device is logically and immediately disconnected from the 1394 bus, no packets are received or processed, nor are packets transmitted.
16	SoftReset	RSCU	When bit 16 is set to 1, all PCI4510 states are reset, all FIFOs are flushed, and all OHCI registers are set to their system (hardware) reset values, unless otherwise specified. PCI registers are not affected by this bit. This bit remains set to 1 while the software reset is in progress and reverts back to 0 when the reset has completed.
15–0	RSVD	R	Reserved. Bits 15–0 return 0s when read.

## 8.17 Self-ID Buffer Pointer Register

The self-ID buffer pointer register points to the 2K-byte aligned base address of the buffer in host memory where the self-ID packets are stored during bus initialization. Bits 31–11 are read/write accessible. Bits 10–0 are reserved, and return 0s when read.

Bit	31	30	29	28	27	26	25	24	23	22	21	20	19	18	17	16
<b>Name</b>	Self-ID buffer pointer															
<b>Type</b>	RW	RW	RW	RW	RW	RW	RW	RW	RW	RW	RW	RW	RW	RW	RW	RW
<b>Default</b>	X	X	X	X	X	X	X	X	X	X	X	X	X	X	X	X
Bit	15	14	13	12	11	10	9	8	7	6	5	4	3	2	1	0
<b>Name</b>	Self-ID buffer pointer															
<b>Type</b>	RW	RW	RW	RW	RW	R	R	R	R	R	R	R	R	R	R	R
<b>Default</b>	X	X	X	X	X	0	0	0	0	0	0	0	0	0	0	0

Register: **Self-ID buffer pointer**  
 Offset: 64h  
 Type: Read/Write, Read-only  
 Default: XXXX XX00h

## 8.18 Self-ID Count Register

The self-ID count register keeps a count of the number of times the bus self-ID process has occurred, flags self-ID packet errors, and keeps a count of the self-ID data in the self-ID buffer. See Table 8–12 for a complete description of the register contents.

Bit	31	30	29	28	27	26	25	24	23	22	21	20	19	18	17	16
<b>Name</b>	Self-ID count															
<b>Type</b>	RU	R	R	R	R	R	R	R	RU	RU	RU	RU	RU	RU	RU	RU
<b>Default</b>	X	0	0	0	0	0	0	0	X	X	X	X	X	X	X	X
Bit	15	14	13	12	11	10	9	8	7	6	5	4	3	2	1	0
<b>Name</b>	Self-ID count															
<b>Type</b>	R	R	R	R	R	RU	RU	RU	RU	RU	RU	RU	RU	RU	R	R
<b>Default</b>	0	0	0	0	0	0	0	0	0	0	0	0	0	0	0	0

Register: **Self-ID count**  
 Offset: 68h  
 Type: Read/Update, Read-only  
 Default: X0XX 0000h

**Table 8–12. Self-ID Count Register Description**

BIT	FIELD NAME	TYPE	DESCRIPTION
31	selfIDError	RU	When bit 31 is set to 1, an error was detected during the most recent self-ID packet reception. The contents of the self-ID buffer are undefined. This bit is cleared after a self-ID reception in which no errors are detected. Note that an error can be a hardware error or a host bus write error.
30–24	RSVD	R	Reserved. Bits 30–24 return 0s when read.
23–16	selfIDGeneration	RU	The value in this field increments each time a bus reset is detected. This field rolls over to 0 after reaching 255.
15–11	RSVD	R	Reserved. Bits 15–11 return 0s when read.
10–2	selfIDSize	RU	This field indicates the number of quadlets that have been written into the self-ID buffer for the current bits 23–16 (selfIDGeneration field). This includes the header quadlet and the self-ID data. This field is cleared to 0s when the self-ID reception begins.
1–0	RSVD	R	Reserved. Bits 1 and 0 return 0s when read.

## 8.19 Isochronous Receive Channel Mask High Register

The isochronous receive channel mask high set/clear register enables packet receives from the upper 32 isochronous data channels. A read from either the set register or clear register returns the content of the isochronous receive channel mask high register. See Table 8–13 for a complete description of the register contents.

Bit	31	30	29	28	27	26	25	24	23	22	21	20	19	18	17	16
<b>Name</b>	Isochronous receive channel mask high															
<b>Type</b>	RSC	RSC	RSC	RSC	RSC	RSC	RSC	RSC	RSC	RSC	RSC	RSC	RSC	RSC	RSC	RSC
<b>Default</b>	X	X	X	X	X	X	X	X	X	X	X	X	X	X	X	X

Bit	15	14	13	12	11	10	9	8	7	6	5	4	3	2	1	0
<b>Name</b>	Isochronous receive channel mask high															
<b>Type</b>	RSC	RSC	RSC	RSC	RSC	RSC	RSC	RSC	RSC	RSC	RSC	RSC	RSC	RSC	RSC	RSC
<b>Default</b>	X	X	X	X	X	X	X	X	X	X	X	X	X	X	X	X

Register: **Isochronous receive channel mask high**  
 Offset: 70h set register  
 74h clear register  
 Type: Read/Set/Clear  
 Default: XXXX XXXXh

**Table 8–13. Isochronous Receive Channel Mask High Register Description**

BIT	FIELD NAME	TYPE	DESCRIPTION
31	isoChannel63	RSC	When bit 31 is set to 1, the PCI4510 device is enabled to receive from isochronous channel number 63.
30	isoChannel62	RSC	When bit 30 is set to 1, the PCI4510 device is enabled to receive from isochronous channel number 62.
29	isoChannel61	RSC	When bit 29 is set to 1, the PCI4510 device is enabled to receive from isochronous channel number 61.
28	isoChannel60	RSC	When bit 28 is set to 1, the PCI4510 device is enabled to receive from isochronous channel number 60.
27	isoChannel59	RSC	When bit 27 is set to 1, the PCI4510 device is enabled to receive from isochronous channel number 59.
26	isoChannel58	RSC	When bit 26 is set to 1, the PCI4510 device is enabled to receive from isochronous channel number 58.
25	isoChannel57	RSC	When bit 25 is set to 1, the PCI4510 device is enabled to receive from isochronous channel number 57.
24	isoChannel56	RSC	When bit 24 is set to 1, the PCI4510 device is enabled to receive from isochronous channel number 56.
23	isoChannel55	RSC	When bit 23 is set to 1, the PCI4510 device is enabled to receive from isochronous channel number 55.
22	isoChannel54	RSC	When bit 22 is set to 1, the PCI4510 device is enabled to receive from isochronous channel number 54.
21	isoChannel53	RSC	When bit 21 is set to 1, the PCI4510 device is enabled to receive from isochronous channel number 53.
20	isoChannel52	RSC	When bit 20 is set to 1, the PCI4510 device is enabled to receive from isochronous channel number 52.
19	isoChannel51	RSC	When bit 19 is set to 1, the PCI4510 device is enabled to receive from isochronous channel number 51.
18	isoChannel50	RSC	When bit 18 is set to 1, the PCI4510 device is enabled to receive from isochronous channel number 50.
17	isoChannel49	RSC	When bit 17 is set to 1, the PCI4510 device is enabled to receive from isochronous channel number 49.
16	isoChannel48	RSC	When bit 16 is set to 1, the PCI4510 device is enabled to receive from isochronous channel number 48.
15	isoChannel47	RSC	When bit 15 is set to 1, the PCI4510 device is enabled to receive from isochronous channel number 47.
14	isoChannel46	RSC	When bit 14 is set to 1, the PCI4510 device is enabled to receive from isochronous channel number 46.
13	isoChannel45	RSC	When bit 13 is set to 1, the PCI4510 device is enabled to receive from isochronous channel number 45.
12	isoChannel44	RSC	When bit 12 is set to 1, the PCI4510 device is enabled to receive from isochronous channel number 44.
11	isoChannel43	RSC	When bit 11 is set to 1, the PCI4510 device is enabled to receive from isochronous channel number 43.
10	isoChannel42	RSC	When bit 10 is set to 1, the PCI4510 device is enabled to receive from isochronous channel number 42.
9	isoChannel41	RSC	When bit 9 is set to 1, the PCI4510 device is enabled to receive from isochronous channel number 41.
8	isoChannel40	RSC	When bit 8 is set to 1, the PCI4510 device is enabled to receive from isochronous channel number 40.
7	isoChannel39	RSC	When bit 7 is set to 1, the PCI4510 device is enabled to receive from isochronous channel number 39.

**Table 8–13. Isochronous Receive Channel Mask High Register Description (Continued)**

BIT	FIELD NAME	TYPE	DESCRIPTION
6	isoChannel38	RSC	When bit 6 is set to 1, the PCI4510 device is enabled to receive from isochronous channel number 38.
5	isoChannel37	RSC	When bit 5 is set to 1, the PCI4510 device is enabled to receive from isochronous channel number 37.
4	isoChannel36	RSC	When bit 4 is set to 1, the PCI4510 device is enabled to receive from isochronous channel number 36.
3	isoChannel35	RSC	When bit 3 is set to 1, the PCI4510 device is enabled to receive from isochronous channel number 35.
2	isoChannel34	RSC	When bit 2 is set to 1, the PCI4510 device is enabled to receive from isochronous channel number 34.
1	isoChannel33	RSC	When bit 1 is set to 1, the PCI4510 device is enabled to receive from isochronous channel number 33.
0	isoChannel32	RSC	When bit 0 is set to 1, the PCI4510 device is enabled to receive from isochronous channel number 32.

## 8.20 Isochronous Receive Channel Mask Low Register

The isochronous receive channel mask low set/clear register enables packet receives from the lower 32 isochronous data channels. See Table 8–14 for a complete description of the register contents.

Bit	31	30	29	28	27	26	25	24	23	22	21	20	19	18	17	16
<b>Name</b>	Isochronous receive channel mask low															
<b>Type</b>	RSC	RSC	RSC	RSC	RSC	RSC	RSC	RSC	RSC	RSC	RSC	RSC	RSC	RSC	RSC	RSC
<b>Default</b>	X	X	X	X	X	X	X	X	X	X	X	X	X	X	X	X
Bit	15	14	13	12	11	10	9	8	7	6	5	4	3	2	1	0
<b>Name</b>	Isochronous receive channel mask low															
<b>Type</b>	RSC	RSC	RSC	RSC	RSC	RSC	RSC	RSC	RSC	RSC	RSC	RSC	RSC	RSC	RSC	RSC
<b>Default</b>	X	X	X	X	X	X	X	X	X	X	X	X	X	X	X	X

Register: **Isochronous receive channel mask low**

Offset: 78h set register

7Ch clear register

Type: Read/Set/Clear

Default: XXXX XXXXh

**Table 8–14. Isochronous Receive Channel Mask Low Register Description**

BIT	FIELD NAME	TYPE	DESCRIPTION
31	isoChannel31	RSC	When bit 31 is set to 1, the PCI4510 device is enabled to receive from isochronous channel number 31.
30	isoChannel30	RSC	When bit 30 is set to 1, the PCI4510 device is enabled to receive from isochronous channel number 30.
29–2	isoChanneln	RSC	Bits 29 through 2 (isoChanneln, where n = 29, 28, 27, ..., 2) follow the same pattern as bits 31 and 30.
1	isoChannel1	RSC	When bit 1 is set to 1, the PCI4510 device is enabled to receive from isochronous channel number 1.
0	isoChannel0	RSC	When bit 0 is set to 1, the PCI4510 device is enabled to receive from isochronous channel number 0.

## 8.21 Interrupt Event Register

The interrupt event set/clear register reflects the state of the various PCI4510 interrupt sources. The interrupt bits are set to 1 by an asserting edge of the corresponding interrupt signal or by writing a 1 in the corresponding bit in the set register. The only mechanism to clear a bit in this register is to write a 1 to the corresponding bit in the clear register.

This register is fully compliant with the *1394 Open Host Controller Interface Specification*, and the PCI4510 device adds a vendor-specific interrupt function to bit 30. When the interrupt event register is read, the return value is the bit-wise AND function of the interrupt event and interrupt mask registers. See Table 8–15 for a complete description of the register contents.

Bit	31	30	29	28	27	26	25	24	23	22	21	20	19	18	17	16
<b>Name</b>	Interrupt event															
<b>Type</b>	R	RSC	RSC	R	RSCU	RSCU	RSCU	RSCU	RSCU	RSCU	RSCU	RSCU	RSCU	RSCU	RSCU	RSCU
<b>Default</b>	0	X	0	0	0	X	X	X	X	X	X	X	X	0	X	X
Bit	15	14	13	12	11	10	9	8	7	6	5	4	3	2	1	0
<b>Name</b>	Interrupt event															
<b>Type</b>	RSCU	R	R	R	R	R	RSCU	RSCU	RU	RU	RSCU	RSCU	RSCU	RSCU	RSCU	RSCU
<b>Default</b>	0	0	0	0	0	0	X	X	X	X	X	X	X	X	X	X

Register: **Interrupt event**  
 Offset: 80h set register  
 84h clear register [returns the content of the interrupt event register bit-wise ANDed with the interrupt mask register when read]  
 Type: Read/Set/Clear/Update, Read/Set/Clear, Read/Update, Read-only  
 Default: XXXX 0XXXh

**Table 8–15. Interrupt Event Register Description**

BIT	FIELD NAME	TYPE	DESCRIPTION
31	RSVD	R	Reserved. Bit 31 returns 0 when read.
30	RSVD	RSC	Reserved. Do not write to this bit.
29	SoftInterrupt	RSC	Bit 29 is used by software to generate a PCI4510 interrupt for its own use.
28	RSVD	R	Reserved. Bit 28 returns 0 when read.
27	ack_tardy	RSCU	Bit 27 is set to 1 when bit 29 (AckTardyEnable) in the host controller control register at OHCI offset 50h/54h (see Section 8.16) is set to 1 and any of the following conditions occur: a. Data is present in a receive FIFO that is to be delivered to the host. b. The physical response unit is busy processing requests or sending responses. c. The PCI4510 device sent an ack_tardy acknowledgment.
26	phyRegRcvd	RSCU	The PCI4510 device has received a PHY register data byte which can be read from bits 23–16 in the PHY layer control register at OHCI offset ECh (see Section 8.33).
25	cycleTooLong	RSCU	If bit 21 (cycleMaster) in the link control register at OHCI offset E0h/E4h (see Section 8.31) is set to 1, then this indicates that over 125 μs has elapsed between the start of sending a cycle start packet and the end of a subaction gap. Bit 21 (cycleMaster) in the link control register is cleared by this event.
24	unrecoverableError	RSCU	This event occurs when the PCI4510 device encounters any error that forces it to stop operations on any or all of its subunits, for example, when a DMA context sets its dead bit to 1. While bit 24 is set to 1, all normal interrupts for the context(s) that caused this interrupt are blocked from being set to 1.
23	cycleInconsistent	RSCU	A cycle start was received that had values for the cycleSeconds and cycleCount fields that are different from the values in bits 31–25 (cycleSeconds field) and bits 24–12 (cycleCount field) in the isochronous cycle timer register at OHCI offset F0h (see Section 8.34).



**Table 8–15. Interrupt Event Register Description (Continued)**

BIT	FIELD NAME	TYPE	DESCRIPTION
22	cycleLost	RSCU	A lost cycle is indicated when no cycle_start packet is sent or received between two successive cycleSynch events. A lost cycle can be predicted when a cycle_start packet does not immediately follow the first subaction gap after the cycleSynch event or if an arbitration reset gap is detected after a cycleSynch event without an intervening cycle start. Bit 22 may be set to 1 either when a lost cycle occurs or when logic predicts that one will occur.
21	cycle64Seconds	RSCU	Indicates that the 7 <sup>th</sup> bit of the cycle second counter has changed.
20	cycleSynch	RSCU	Indicates that a new isochronous cycle has started. Bit 20 is set to 1 when the low-order bit of the cycle count toggles.
19	phy	RSCU	Indicates that the PHY layer requests an interrupt through a status transfer.
18	regAccessFail	RSCU	Indicates that a PCI4510 register access has failed due to a missing SCLK clock signal from the PHY layer. When a register access fails, bit 18 is set to 1 before the next register access.
17	busReset	RSCU	Indicates that the PHY layer has entered bus reset mode.
16	selfIDcomplete	RSCU	A self-ID packet stream has been received. It is generated at the end of the bus initialization process. Bit 16 is turned off simultaneously when bit 17 (busReset) is turned on.
15	selfIDcomplete2	RSCU	Secondary indication of the end of a self-ID packet stream. Bit 15 is set to 1 by the PCI4510 device when it sets bit 16 (selfIDcomplete), and retains the state, independent of bit 17 (busReset).
14–10	RSVD	R	Reserved. Bits 14–10 return 0s when read.
9	lockRespErr	RSCU	Indicates that the PCI4510 device sent a lock response for a lock request to a serial bus register, but did not receive an ack_complete.
8	postedWriteErr	RSCU	Indicates that a host bus error occurred while the PCI4510 device was trying to write a 1394 write request, which had already been given an ack_complete, into system memory.
7	isochRx	RU	Isochronous receive DMA interrupt. Indicates that one or more isochronous receive contexts have generated an interrupt. This is not a latched event; it is the logical OR of all bits in the isochronous receive interrupt event register at OHCI offset A0h/A4h (see Section 8.25) and isochronous receive interrupt mask register at OHCI offset A8h/ACh (see Section 8.26). The isochronous receive interrupt event register indicates which contexts have been interrupted.
6	isochTx	RU	Isochronous transmit DMA interrupt. Indicates that one or more isochronous transmit contexts have generated an interrupt. This is not a latched event; it is the logical OR of all bits in the isochronous transmit interrupt event register at OHCI offset 90h/94h (see Section 8.23) and isochronous transmit interrupt mask register at OHCI offset 98h/9Ch (see Section 8.24). The isochronous transmit interrupt event register indicates which contexts have been interrupted.
5	RSPkt	RSCU	Indicates that a packet was sent to an asynchronous receive response context buffer and the descriptor xferStatus and resCount fields have been updated.
4	RQPkt	RSCU	Indicates that a packet was sent to an asynchronous receive request context buffer and the descriptor xferStatus and resCount fields have been updated.
3	ARRS	RSCU	Asynchronous receive response DMA interrupt. Bit 3 is conditionally set to 1 upon completion of an ARRS DMA context command descriptor.
2	ARRQ	RSCU	Asynchronous receive request DMA interrupt. Bit 2 is conditionally set to 1 upon completion of an ARRQ DMA context command descriptor.
1	respTxComplete	RSCU	Asynchronous response transmit DMA interrupt. Bit 1 is conditionally set to 1 upon completion of an ATRS DMA command.
0	reqTxComplete	RSCU	Asynchronous request transmit DMA interrupt. Bit 0 is conditionally set to 1 upon completion of an ATRQ DMA command.

## 8.22 Interrupt Mask Register

The interrupt mask set/clear register enables the various PCI4510 interrupt sources. Reads from either the set register or the clear register always return the contents of the interrupt mask register. In all cases except masterIntEnable (bit 31) and vendorSpecific (bit 30), the enables for each interrupt event align with the interrupt event register bits detailed in Table 8–15.

This register is fully compliant with the *1394 Open Host Controller Interface Specification* and the PCI4510 device adds an interrupt function to bit 30. See Table 8–16 for a complete description of bits 31 and 30.

Bit	31	30	29	28	27	26	25	24	23	22	21	20	19	18	17	16
<b>Name</b>	Interrupt mask															
<b>Type</b>	RSCU	RSC	RSC	R	RSC	RSC	RSC	RSC	RSC	RSC	RSC	RSC	RSC	RSC	RSC	RSC
<b>Default</b>	X	X	0	0	0	X	X	X	X	X	X	X	X	0	X	X
Bit	15	14	13	12	11	10	9	8	7	6	5	4	3	2	1	0
<b>Name</b>	Interrupt mask															
<b>Type</b>	RSC	R	R	R	R	R	RSC	RSC	RSC	RSC	RSC	RSC	RSC	RSC	RSC	RSC
<b>Default</b>	0	0	0	0	0	0	X	X	X	X	X	X	X	X	X	X

Register: **Interrupt mask**  
 Offset: 88h set register  
 8Ch clear register  
 Type: Read/Set/Clear/Update, Read/Set/Clear, Read/Update, Read-only  
 Default: XXXX 0XXXh

**Table 8–16. Interrupt Mask Register Description**

BIT	FIELD NAME	TYPE	DESCRIPTION
31	masterIntEnable	RSCU	Master interrupt enable. If bit 31 is set to 1, then external interrupts are generated in accordance with the interrupt mask register. If this bit is cleared, then external interrupts are not generated regardless of the interrupt mask register settings.
30	VendorSpecific	RSC	When this bit and bit 30 (vendorSpecific) in the interrupt event register at OHCI offset 80h/84h (see Section 8.21) are set to 1, this vendor-specific interrupt mask enables interrupt generation.
29	SoftInterrupt	RSC	When this bit and bit 29 (SoftInterrupt) in the interrupt event register at OHCI offset 80h/84h (see Section 8.21) are set to 1, this soft-interrupt mask enables interrupt generation.
28	RSVD	R	Reserved. Bit 28 returns 0 when read.
27	ack_tardy	RSC	When this bit and bit 27 (ack_tardy) in the interrupt event register at OHCI offset 80h/84h (see Section 8.21) are set to 1, this acknowledge-tardy interrupt mask enables interrupt generation.
26	phyRegRcvd	RSC	When this bit and bit 26 (phyRegRcvd) in the interrupt event register at OHCI offset 80h/84h (see Section 8.21) are set to 1, this PHY-register interrupt mask enables interrupt generation.
25	cycleTooLong	RSC	When this bit and bit 25 (cycleTooLong) in the interrupt event register at OHCI offset 80h/84h (see Section 8.21) are set to 1, this cycle-too-long interrupt mask enables interrupt generation.
24	unrecoverableError	RSC	When this bit and bit 24 (unrecoverableError) in the interrupt event register at OHCI offset 80h/84h (see Section 8.21) are set to 1, this unrecoverable-error interrupt mask enables interrupt generation.
23	cycleInconsistent	RSC	When this bit and bit 23 (cycleInconsistent) in the interrupt event register at OHCI offset 80h/84h (see Section 8.21) are set to 1, this inconsistent-cycle interrupt mask enables interrupt generation.
22	cycleLost	RSC	When this bit and bit 22 (cycleLost) in the interrupt event register at OHCI offset 80h/84h (see Section 8.21) are set to 1, this lost-cycle interrupt mask enables interrupt generation.
21	cycle64Seconds	RSC	When this bit and bit 21 (cycle64Seconds) in the interrupt event register at OHCI offset 80h/84h (see Section 8.21) are set to 1, this 64-second-cycle interrupt mask enables interrupt generation.
20	cycleSynch	RSC	When this bit and bit 20 (cycleSynch) in the interrupt event register at OHCI offset 80h/84h (see Section 8.21) are set to 1, this isochronous-cycle interrupt mask enables interrupt generation.
19	phy	RSC	When this bit and bit 19 (phy) in the interrupt event register at OHCI offset 80h/84h (see Section 8.21) are set to 1, this PHY-status-transfer interrupt mask enables interrupt generation.

**Table 8–16. Interrupt Mask Register Description (Continued)**

BIT	FIELD NAME	TYPE	DESCRIPTION
18	regAccessFail	RSC	When this bit and bit 18 (regAccessFail) in the interrupt event register at OHCI offset 80h/84h (see Section 8.21) are set to 1, this register-access-failed interrupt mask enables interrupt generation.
17	busReset	RSC	When this bit and bit 17 (busReset) in the interrupt event register at OHCI offset 80h/84h (see Section 8.21) are set to 1, this bus-reset interrupt mask enables interrupt generation.
16	selfIDcomplete	RSC	When this bit and bit 16 (selfIDcomplete) in the interrupt event register at OHCI offset 80h/84h (see Section 8.21) are set to 1, this self-ID-complete interrupt mask enables interrupt generation.
15	selfIDcomplete2	RSC	When this bit and bit 15 (selfIDcomplete2) in the interrupt event register at OHCI offset 80h/84h (see Section 8.21) are set to 1, this second-self-ID-complete interrupt mask enables interrupt generation.
14–10	RSVD	R	Reserved. Bits 14–10 return 0s when read.
9	lockRespErr	RSC	When this bit and bit 9 (lockRespErr) in the interrupt event register at OHCI offset 80h/84h (see Section 8.21) are set to 1, this lock-response-error interrupt mask enables interrupt generation.
8	postedWriteErr	RSC	When this bit and bit 8 (postedWriteErr) in the interrupt event register at OHCI offset 80h/84h (see Section 8.21) are set to 1, this posted-write-error interrupt mask enables interrupt generation.
7	isochRx	RSC	When this bit and bit 7 (isochRx) in the interrupt event register at OHCI offset 80h/84h (see Section 8.21) are set to 1, this isochronous-receive-DMA interrupt mask enables interrupt generation.
6	isochTx	RSC	When this bit and bit 6 (isochTx) in the interrupt event register at OHCI offset 80h/84h (see Section 8.21) are set to 1, this isochronous-transmit-DMA interrupt mask enables interrupt generation.
5	RSPkt	RSC	When this bit and bit 5 (RSPkt) in the interrupt event register at OHCI offset 80h/84h (see Section 8.21) are set to 1, this receive-response-packet interrupt mask enables interrupt generation.
4	RQPkt	RSC	When this bit and bit 4 (RQPkt) in the interrupt event register at OHCI offset 80h/84h (see Section 8.21) are set to 1, this receive-request-packet interrupt mask enables interrupt generation.
3	ARRS	RSC	When this bit and bit 3 (ARRS) in the interrupt event register at OHCI offset 80h/84h (see Section 8.21) are set to 1, this asynchronous-receive-response-DMA interrupt mask enables interrupt generation.
2	ARRQ	RSC	When this bit and bit 2 (ARRQ) in the interrupt event register at OHCI offset 80h/84h (see Section 8.21) are set to 1, this asynchronous-receive-request-DMA interrupt mask enables interrupt generation.
1	respTxComplete	RSC	When this bit and bit 1 (respTxComplete) in the interrupt event register at OHCI offset 80h/84h (see Section 8.21) are set to 1, this response-transmit-complete interrupt mask enables interrupt generation.
0	reqTxComplete	RSC	When this bit and bit 0 (reqTxComplete) in the interrupt event register at OHCI offset 80h/84h (see Section 8.21) are set to 1, this request-transmit-complete interrupt mask enables interrupt generation.

## 8.23 Isochronous Transmit Interrupt Event Register

The isochronous transmit interrupt event set/clear register reflects the interrupt state of the isochronous transmit contexts. An interrupt is generated on behalf of an isochronous transmit context if an OUTPUT\_LAST\* command completes and its interrupt bits are set to 1. Upon determining that the isochTx (bit 6) interrupt has occurred in the interrupt event register at OHCI offset 80h/84h (see Section 8.21), software can check this register to determine which context(s) caused the interrupt. The interrupt bits are set to 1 by an asserting edge of the corresponding interrupt signal, or by writing a 1 in the corresponding bit in the set register. The only mechanism to clear a bit in this register is to write a 1 to the corresponding bit in the clear register. See Table 8–17 for a complete description of the register contents.

Bit	31	30	29	28	27	26	25	24	23	22	21	20	19	18	17	16
Name	Isochronous transmit interrupt event															
Type	R	R	R	R	R	R	R	R	R	R	R	R	R	R	R	R
Default	0	0	0	0	0	0	0	0	0	0	0	0	0	0	0	0
Bit	15	14	13	12	11	10	9	8	7	6	5	4	3	2	1	0
Name	Isochronous transmit interrupt event															
Type	R	R	R	R	R	R	R	R	RSC	RSC	RSC	RSC	RSC	RSC	RSC	RSC
Default	0	0	0	0	0	0	0	0	X	X	X	X	X	X	X	X

Register: **Isochronous transmit interrupt event**  
 Offset: 90h set register  
 94h clear register [returns the contents of the isochronous transmit interrupt event register bit-wise ANDed with the isochronous transmit interrupt mask register when read]  
 Type: Read/Set/Clear, Read-only  
 Default: 0000 00XXh

**Table 8–17. Isochronous Transmit Interrupt Event Register Description**

BIT	FIELD NAME	TYPE	DESCRIPTION
31–8	RSVD	R	Reserved. Bits 31–8 return 0s when read.
7	isoXmit7	RSC	Isochronous transmit channel 7 caused the interrupt event register bit 6 (isochTx) interrupt.
6	isoXmit6	RSC	Isochronous transmit channel 6 caused the interrupt event register bit 6 (isochTx) interrupt.
5	isoXmit5	RSC	Isochronous transmit channel 5 caused the interrupt event register bit 6 (isochTx) interrupt.
4	isoXmit4	RSC	Isochronous transmit channel 4 caused the interrupt event register bit 6 (isochTx) interrupt.
3	isoXmit3	RSC	Isochronous transmit channel 3 caused the interrupt event register bit 6 (isochTx) interrupt.
2	isoXmit2	RSC	Isochronous transmit channel 2 caused the interrupt event register bit 6 (isochTx) interrupt.
1	isoXmit1	RSC	Isochronous transmit channel 1 caused the interrupt event register bit 6 (isochTx) interrupt.
0	isoXmit0	RSC	Isochronous transmit channel 0 caused the interrupt event register bit 6 (isochTx) interrupt.

## 8.24 Isochronous Transmit Interrupt Mask Register

The isochronous transmit interrupt mask set/clear register enables the isochTx interrupt source on a per-channel basis. Reads from either the set register or the clear register always return the contents of the isochronous transmit interrupt mask register. In all cases the enables for each interrupt event align with the isochronous transmit interrupt event register bits detailed in Table 8–17.

<b>Bit</b>	<b>31</b>	<b>30</b>	<b>29</b>	<b>28</b>	<b>27</b>	<b>26</b>	<b>25</b>	<b>24</b>	<b>23</b>	<b>22</b>	<b>21</b>	<b>20</b>	<b>19</b>	<b>18</b>	<b>17</b>	<b>16</b>
<b>Name</b>	Isochronous transmit interrupt mask															
<b>Type</b>	R	R	R	R	R	R	R	R	R	R	R	R	R	R	R	R
<b>Default</b>	0	0	0	0	0	0	0	0	0	0	0	0	0	0	0	0
<b>Bit</b>	<b>15</b>	<b>14</b>	<b>13</b>	<b>12</b>	<b>11</b>	<b>10</b>	<b>9</b>	<b>8</b>	<b>7</b>	<b>6</b>	<b>5</b>	<b>4</b>	<b>3</b>	<b>2</b>	<b>1</b>	<b>0</b>
<b>Name</b>	Isochronous transmit interrupt mask															
<b>Type</b>	R	R	R	R	R	R	R	R	RSC	RSC	RSC	RSC	RSC	RSC	RSC	RSC
<b>Default</b>	0	0	0	0	0	0	0	0	X	X	X	X	X	X	X	X

Register: **Isochronous transmit interrupt mask**  
 Offset: 98h set register  
           9Ch clear register  
 Type: Read/Set/Clear, Read-only  
 Default: 0000 00XXh

## 8.25 Isochronous Receive Interrupt Event Register

The isochronous receive interrupt event set/clear register reflects the interrupt state of the isochronous receive contexts. An interrupt is generated on behalf of an isochronous receive context if an INPUT\_\* command completes and its interrupt bits are set to 1. Upon determining that the isoChRx (bit 7) interrupt in the interrupt event register at OHCI offset 80h/84h (see Section 8.21) has occurred, software can check this register to determine which context(s) caused the interrupt. The interrupt bits are set to 1 by an asserting edge of the corresponding interrupt signal or by writing a 1 in the corresponding bit in the set register. The only mechanism to clear a bit in this register is to write a 1 to the corresponding bit in the clear register. See Table 8–18 for a complete description of the register contents.

Bit	31	30	29	28	27	26	25	24	23	22	21	20	19	18	17	16
Name	Isochronous receive interrupt event															
Type	R	R	R	R	R	R	R	R	R	R	R	R	R	R	R	R
Default	0	0	0	0	0	0	0	0	0	0	0	0	0	0	0	0
Bit	15	14	13	12	11	10	9	8	7	6	5	4	3	2	1	0
Name	Isochronous receive interrupt event															
Type	R	R	R	R	R	R	R	R	R	R	R	R	RSC	RSC	RSC	RSC
Default	0	0	0	0	0	0	0	0	0	0	0	0	X	X	X	X

Register: **Isochronous receive interrupt event**  
 Offset: A0h set register  
 A4h clear register [returns the contents of isochronous receive interrupt event register bit-wise ANDed with the isochronous receive mask register when read]  
 Type: Read/Set/Clear, Read-only  
 Default: 0000 000Xh

**Table 8–18. Isochronous Receive Interrupt Event Register Description**

BIT	FIELD NAME	TYPE	DESCRIPTION
31–4	RSVD	R	Reserved. Bits 31–4 return 0s when read.
3	isoRecv3	RSC	Isochronous receive channel 3 caused the interrupt event register bit 7 (isoChRx) interrupt.
2	isoRecv2	RSC	Isochronous receive channel 2 caused the interrupt event register bit 7 (isoChRx) interrupt.
1	isoRecv1	RSC	Isochronous receive channel 1 caused the interrupt event register bit 7 (isoChRx) interrupt.
0	isoRecv0	RSC	Isochronous receive channel 0 caused the interrupt event register bit 7 (isoChRx) interrupt.

## 8.26 Isochronous Receive Interrupt Mask Register

The isochronous receive interrupt mask set/clear register enables the isochRx interrupt source on a per-channel basis. Reads from either the set register or the clear register always return the contents of the isochronous receive interrupt mask register. In all cases the enables for each interrupt event align with the isochronous receive interrupt event register bits detailed in Table 8–18.

Bit	31	30	29	28	27	26	25	24	23	22	21	20	19	18	17	16
<b>Name</b>	Isochronous receive interrupt mask															
<b>Type</b>	R	R	R	R	R	R	R	R	R	R	R	R	R	R	R	R
<b>Default</b>	0	0	0	0	0	0	0	0	0	0	0	0	0	0	0	0
Bit	15	14	13	12	11	10	9	8	7	6	5	4	3	2	1	0
<b>Name</b>	Isochronous receive interrupt mask															
<b>Type</b>	R	R	R	R	R	R	R	R	R	R	R	R	RSC	RSC	RSC	RSC
<b>Default</b>	0	0	0	0	0	0	0	0	0	0	0	0	X	X	X	X

Register: **Isochronous receive interrupt mask**  
 Offset: A8h set register  
           ACh clear register  
 Type: Read/Set/Clear, Read-only  
 Default: 0000 000Xh

## 8.27 Initial Bandwidth Available Register

The initial bandwidth available register value is loaded into the corresponding bus management CSR register on a system (hardware) or software reset. See Table 8–19 for a complete description of the register contents.

Bit	31	30	29	28	27	26	25	24	23	22	21	20	19	18	17	16
<b>Name</b>	Initial bandwidth available															
<b>Type</b>	R	R	R	R	R	R	R	R	R	R	R	R	R	R	R	R
<b>Default</b>	0	0	0	0	0	0	0	0	0	0	0	0	0	0	0	0
Bit	15	14	13	12	11	10	9	8	7	6	5	4	3	2	1	0
<b>Name</b>	Initial bandwidth available															
<b>Type</b>	R	R	R	RW	RW	RW	RW	RW	RW	RW	RW	RW	RW	RW	RW	RW
<b>Default</b>	0	0	0	1	0	0	1	1	0	0	1	1	0	0	1	1

Register: **Initial bandwidth available**  
 Offset: B0h  
 Type: Read-only, Read/Write  
 Default: 0000 1333h

**Table 8–19. Initial Bandwidth Available Register Description**

BIT	FIELD NAME	TYPE	DESCRIPTION
31–13	RSVD	R	Reserved. Bits 31–13 return 0s when read.
12–0	InitBWAvailable	RW	This field is reset to 1333h on a system (hardware) or software reset, and is not affected by a 1394 bus reset. The value of this field is loaded into the BANDWIDTH_AVAILABLE CSR register upon a GRST, PRST, or a 1394 bus reset.

## 8.28 Initial Channels Available High Register

The initial channels available high register value is loaded into the corresponding bus management CSR register on a system (hardware) or software reset. See Table 8–20 for a complete description of the register contents.

Bit	31	30	29	28	27	26	25	24	23	22	21	20	19	18	17	16
Name	Initial channels available high															
Type	RW	RW	RW	RW	RW	RW	RW	RW	RW	RW	RW	RW	RW	RW	RW	RW
Default	1	1	1	1	1	1	1	1	1	1	1	1	1	1	1	1
Bit	15	14	13	12	11	10	9	8	7	6	5	4	3	2	1	0
Name	Initial channels available high															
Type	RW	RW	RW	RW	RW	RW	RW	RW	RW	RW	RW	RW	RW	RW	RW	RW
Default	1	1	1	1	1	1	1	1	1	1	1	1	1	1	1	1

Register: **Initial channels available high**

Offset: B4h

Type: Read/Write

Default: FFFF FFFFh

**Table 8–20. Initial Channels Available High Register Description**

BIT	FIELD NAME	TYPE	DESCRIPTION
31–0	InitChanAvailHi	RW	This field is reset to FFFF_FFFFh on a system (hardware) or software reset, and is not affected by a 1394 bus reset. The value of this field is loaded into the CHANNELS_AVAILABLE_HI CSR register upon a GRST, PRST, or a 1394 bus reset.

## 8.29 Initial Channels Available Low Register

The initial channels available low register value is loaded into the corresponding bus management CSR register on a system (hardware) or software reset. See Table 8–21 for a complete description of the register contents.

Bit	31	30	29	28	27	26	25	24	23	22	21	20	19	18	17	16
Name	Initial channels available low															
Type	RW	RW	RW	RW	RW	RW	RW	RW	RW	RW	RW	RW	RW	RW	RW	RW
Default	1	1	1	1	1	1	1	1	1	1	1	1	1	1	1	1
Bit	15	14	13	12	11	10	9	8	7	6	5	4	3	2	1	0
Name	Initial channels available low															
Type	RW	RW	RW	RW	RW	RW	RW	RW	RW	RW	RW	RW	RW	RW	RW	RW
Default	1	1	1	1	1	1	1	1	1	1	1	1	1	1	1	1

Register: **Initial channels available low**

Offset: B8h

Type: Read/Write

Default: FFFF FFFFh

**Table 8–21. Initial Channels Available Low Register Description**

BIT	FIELD NAME	TYPE	DESCRIPTION
31–0	InitChanAvailLo	RW	This field is reset to FFFF_FFFFh on a system (hardware) or software reset, and is not affected by a 1394 bus reset. The value of this field is loaded into the CHANNELS_AVAILABLE_LO CSR register upon a GRST, PRST, or a 1394 bus reset.



### 8.30 Fairness Control Register

The fairness control register provides a mechanism by which software can direct the host controller to transmit multiple asynchronous requests during a fairness interval. See Table 8–22 for a complete description of the register contents.

<b>Bit</b>	31	30	29	28	27	26	25	24	23	22	21	20	19	18	17	16
<b>Name</b>	Fairness control															
<b>Type</b>	R	R	R	R	R	R	R	R	R	R	R	R	R	R	R	R
<b>Default</b>	0	0	0	0	0	0	0	0	0	0	0	0	0	0	0	0
<b>Bit</b>	15	14	13	12	11	10	9	8	7	6	5	4	3	2	1	0
<b>Name</b>	Fairness control															
<b>Type</b>	R	R	R	R	R	R	R	R	RW	RW	RW	RW	RW	RW	RW	RW
<b>Default</b>	0	0	0	0	0	0	0	0	0	0	0	0	0	0	0	0

Register: **Fairness control**  
 Offset: DCh  
 Type: Read-only  
 Default: 0000 0000h

**Table 8–22. Fairness Control Register Description**

BIT	FIELD NAME	TYPE	DESCRIPTION
31–8	RSVD	R	Reserved. Bits 31–8 return 0s when read.
7–0	pri_req	RW	This field specifies the maximum number of priority arbitration requests for asynchronous request packets that the link is permitted to make of the PHY layer during a fairness interval.

## 8.31 Link Control Register

The link control set/clear register provides the control flags that enable and configure the link core protocol portions of the PCI4510 device. It contains controls for the receiver and cycle timer. See Table 8–23 for a complete description of the register contents.

Bit	31	30	29	28	27	26	25	24	23	22	21	20	19	18	17	16
Name	Link control															
Type	R	R	R	R	R	R	R	R	R	RSC	RSCU	RSC	R	R	R	R
Default	0	0	0	0	0	0	0	0	0	X	X	X	0	0	0	0
Bit	15	14	13	12	11	10	9	8	7	6	5	4	3	2	1	0
Name	Link control															
Type	R	R	R	R	R	RSC	RSC	R	R	RS	R	R	R	R	R	R
Default	0	0	0	0	0	X	X	0	0	0	0	0	0	0	0	0

Register: **Link control**  
 Offset: E0h set register  
 E4h clear register  
 Type: Read/Set/Clear/Update, Read/Set/Clear, Read-only  
 Default: 00X0 0X00h

**Table 8–23. Link Control Register Description**

BIT	FIELD NAME	TYPE	DESCRIPTION
31–23	RSVD	R	Reserved. Bits 31–23 return 0s when read.
22	cycleSource	RSC	When bit 22 is set to 1, the cycle timer uses an external source (CYCLEIN) to determine when to roll over the cycle timer. When this bit is cleared, the cycle timer rolls over when the timer reaches 3072 cycles of the 24.576-MHz clock (125 μs).
21	cycleMaster	RSCU	When bit 21 is set to 1, the PCI4510 device is root and it generates a cycle start packet every time the cycle timer rolls over, based on the setting of bit 22 (cycleSource). When bit 21 is cleared, the OHCI-Lynx™ accepts received cycle start packets to maintain synchronization with the node which is sending them. Bit 21 is automatically cleared when bit 25 (cycleTooLong) in the interrupt event register at OHCI offset 80h/84h (see Section 8.21) is set to 1. Bit 21 cannot be set to 1 until bit 25 (cycleTooLong) is cleared.
20	CycleTimerEnable	RSC	When bit 20 is set to 1, the cycle timer offset counts cycles of the 24.576-MHz clock and rolls over at the appropriate time, based on the settings of the above bits. When this bit is cleared, the cycle timer offset does not count.
19–11	RSVD	R	Reserved. Bits 19–11 return 0s when read.
10	RcvPhyPkt	RSC	When bit 10 is set to 1, the receiver accepts incoming PHY packets into the AR request context if the AR request context is enabled. This bit does not control receipt of self-identification packets.
9	RcvSelfID	RSC	When bit 9 is set to 1, the receiver accepts incoming self-identification packets. Before setting this bit to 1, software must ensure that the self-ID buffer pointer register contains a valid address.
8–7	RSVD	R	Reserved. Bits 8 and 7 return 0s when read.
6	tag1SyncFilterLock	RS	When bit 6 is set to 1, bit 6 (tag1SyncFilter) in the isochronous receive context match register (see Section 8.46) is set to 1 for all isochronous receive contexts. When bit 6 is cleared, bit 6 (tag1SyncFilter) in the isochronous receive context match register has read/write access. This bit is cleared when $\overline{\text{GRST}}$ is asserted.
5–0	RSVD	R	Reserved. Bits 5–0 return 0s when read.

## 8.32 Node Identification Register

The node identification register contains the address of the node on which the OHCI-Lynx™ chip resides, and indicates the valid node number status. The 16-bit combination of the busNumber field (bits 15–6) and the NodeNumber field (bits 5–0) is referred to as the node ID. See Table 8–24 for a complete description of the register contents.

<b>Bit</b>	31	30	29	28	27	26	25	24	23	22	21	20	19	18	17	16
<b>Name</b>	Node identification															
<b>Type</b>	RU	RU	R	R	RU	R	R	R	R	R	R	R	R	R	R	R
<b>Default</b>	0	0	0	0	0	0	0	0	0	0	0	0	0	0	0	0
<b>Bit</b>	15	14	13	12	11	10	9	8	7	6	5	4	3	2	1	0
<b>Name</b>	Node identification															
<b>Type</b>	RWU	RWU	RWU	RWU	RWU	RWU	RWU	RWU	RWU	RWU	RU	RU	RU	RU	RU	RU
<b>Default</b>	1	1	1	1	1	1	1	1	1	1	X	X	X	X	X	X

Register: **Node identification**  
 Offset: E8h  
 Type: Read/Write/Update, Read/Update, Read-only  
 Default: 0000 FFXXh

**Table 8–24. Node Identification Register Description**

BIT	FIELD NAME	TYPE	DESCRIPTION
31	iDValid	RU	Bit 31 indicates whether or not the PCI4510 device has a valid node number. It is cleared when a 1394 bus reset is detected and set to 1 when the PCI4510 device receives a new node number from its PHY layer.
30	root	RU	Bit 30 is set to 1 during the bus reset process if the attached PHY layer is root.
29–28	RSVD	R	Reserved. Bits 29 and 28 return 0s when read.
27	CPS	RU	Bit 27 is set to 1 if the PHY layer is reporting that cable power status is OK.
26–16	RSVD	R	Reserved. Bits 26–16 return 0s when read.
15–6	busNumber	RWU	This field identifies the specific 1394 bus the PCI4510 device belongs to when multiple 1394-compatible buses are connected via a bridge.
5–0	NodeNumber	RU	This field is the physical node number established by the PHY layer during self-identification. It is automatically set to the value received from the PHY layer after the self-identification phase. If the PHY layer sets the nodeNumber to 63, then software must not set bit 15 (run) in the asynchronous context control register (see Section 8.40) for either of the AT DMA contexts.

### 8.33 PHY Layer Control Register

The PHY layer control register reads from or writes to a PHY register. See Table 8–25 for a complete description of the register contents.

<b>Bit</b>	<b>31</b>	<b>30</b>	<b>29</b>	<b>28</b>	<b>27</b>	<b>26</b>	<b>25</b>	<b>24</b>	<b>23</b>	<b>22</b>	<b>21</b>	<b>20</b>	<b>19</b>	<b>18</b>	<b>17</b>	<b>16</b>
<b>Name</b>	PHY layer control															
<b>Type</b>	RU	R	R	R	RU	RU	RU	RU	RU	RU	RU	RU	RU	RU	RU	RU
<b>Default</b>	0	0	0	0	0	0	0	0	0	0	0	0	0	0	0	0
<b>Bit</b>	<b>15</b>	<b>14</b>	<b>13</b>	<b>12</b>	<b>11</b>	<b>10</b>	<b>9</b>	<b>8</b>	<b>7</b>	<b>6</b>	<b>5</b>	<b>4</b>	<b>3</b>	<b>2</b>	<b>1</b>	<b>0</b>
<b>Name</b>	PHY layer control															
<b>Type</b>	RWU	RWU	R	R	RW	RW	RW	RW	RW	RW	RW	RW	RW	RW	RW	RW
<b>Default</b>	0	0	0	0	0	0	0	0	0	0	0	0	0	0	0	0

Register: **PHY layer control**  
 Offset: ECh  
 Type: Read/Write/Update, Read/Write, Read/Update, Read-only  
 Default: 0000 0000h

**Table 8–25. PHY Control Register Description**

<b>BIT</b>	<b>FIELD NAME</b>	<b>TYPE</b>	<b>DESCRIPTION</b>
31	rdDone	RU	Bit 31 is cleared to 0 by the PCI4510 device when either bit 15 (rdReg) or bit 14 (wrReg) is set to 1. This bit is set to 1 when a register transfer is received from the PHY layer.
30–28	RSVD	R	Reserved. Bits 30–28 return 0s when read.
27–24	rdAddr	RU	This field is the address of the register most recently received from the PHY layer.
23–16	rdData	RU	This field is the contents of a PHY register that has been read.
15	rdReg	RWU	Bit 15 is set to 1 by software to initiate a read request to a PHY register, and is cleared by hardware when the request has been sent. Bits 14 (wrReg) and 15 (rdReg) must not both be set to 1 simultaneously.
14	wrReg	RWU	Bit 14 is set to 1 by software to initiate a write request to a PHY register, and is cleared by hardware when the request has been sent. Bits 14 (wrReg) and 15 (rdReg) must not both be set to 1 simultaneously.
13–12	RSVD	R	Reserved. Bits 13 and 12 return 0s when read.
11–8	regAddr	RW	This field is the address of the PHY register to be written or read.
7–0	wrData	RW	This field is the data to be written to a PHY register and is ignored for reads.

## 8.34 Isochronous Cycle Timer Register

The isochronous cycle timer register indicates the current cycle number and offset. When the PCI4510 device is cycle master, this register is transmitted with the cycle start message. When the PCI4510 device is not cycle master, this register is loaded with the data field in an incoming cycle start. In the event that the cycle start message is not received, the fields can continue incrementing on their own (if programmed) to maintain a local time reference. See Table 8–26 for a complete description of the register contents.

<b>Bit</b>	<b>31</b>	<b>30</b>	<b>29</b>	<b>28</b>	<b>27</b>	<b>26</b>	<b>25</b>	<b>24</b>	<b>23</b>	<b>22</b>	<b>21</b>	<b>20</b>	<b>19</b>	<b>18</b>	<b>17</b>	<b>16</b>
<b>Name</b>	Isochronous cycle timer															
<b>Type</b>	RWU	RWU	RWU	RWU	RWU	RWU	RWU	RWU	RWU	RWU	RWU	RWU	RWU	RWU	RWU	RWU
<b>Default</b>	X	X	X	X	X	X	X	X	X	X	X	X	X	X	X	X
<b>Bit</b>	<b>15</b>	<b>14</b>	<b>13</b>	<b>12</b>	<b>11</b>	<b>10</b>	<b>9</b>	<b>8</b>	<b>7</b>	<b>6</b>	<b>5</b>	<b>4</b>	<b>3</b>	<b>2</b>	<b>1</b>	<b>0</b>
<b>Name</b>	Isochronous cycle timer															
<b>Type</b>	RWU	RWU	RWU	RWU	RWU	RWU	RWU	RWU	RWU	RWU	RWU	RWU	RWU	RWU	RWU	RWU
<b>Default</b>	X	X	X	X	X	X	X	X	X	X	X	X	X	X	X	X

Register: **Isochronous cycle timer**  
 Offset: F0h  
 Type: Read/Write/Update  
 Default: XXXX XXXXh

**Table 8–26. Isochronous Cycle Timer Register Description**

BIT	FIELD NAME	TYPE	DESCRIPTION
31–25	cycleSeconds	RWU	This field counts seconds [rollovers from bits 24–12 (cycleCount field)] modulo 128.
24–12	cycleCount	RWU	This field counts cycles [rollovers from bits 11–0 (cycleOffset field)] modulo 8000.
11–0	cycleOffset	RWU	This field counts 24.576-MHz clocks modulo 3072, that is, 125 μs. If an external 8-kHz clock configuration is being used, then this field must be cleared to 0s at each tick of the external clock.

## 8.35 Asynchronous Request Filter High Register

The asynchronous request filter high set/clear register enables asynchronous receive requests on a per-node basis, and handles the upper node IDs. When a packet is destined for either the physical request context or the ARRQ context, the source node ID is examined. If the bit corresponding to the node ID is not set to 1 in this register, then the packet is not acknowledged and the request is not queued. The node ID comparison is done if the source node is on the same bus as the PCI4510 device. Nonlocal bus-sourced packets are not acknowledged unless bit 31 in this register is set to 1. See Table 8–27 for a complete description of the register contents.

Bit	31	30	29	28	27	26	25	24	23	22	21	20	19	18	17	16
<b>Name</b>	Asynchronous request filter high															
<b>Type</b>	RSC	RSC	RSC	RSC	RSC	RSC	RSC	RSC	RSC	RSC	RSC	RSC	RSC	RSC	RSC	RSC
<b>Default</b>	0	0	0	0	0	0	0	0	0	0	0	0	0	0	0	0
Bit	15	14	13	12	11	10	9	8	7	6	5	4	3	2	1	0
<b>Name</b>	Asynchronous request filter high															
<b>Type</b>	RSC	RSC	RSC	RSC	RSC	RSC	RSC	RSC	RSC	RSC	RSC	RSC	RSC	RSC	RSC	RSC
<b>Default</b>	0	0	0	0	0	0	0	0	0	0	0	0	0	0	0	0

Register: **Asynchronous request filter high**  
 Offset: 100h set register  
           104h clear register  
 Type: Read/Set/Clear  
 Default: 0000 0000h

**Table 8–27. Asynchronous Request Filter High Register Description**

BIT	FIELD NAME	TYPE	DESCRIPTION
31	asynReqAllBuses	RSC	If bit 31 is set to 1, all asynchronous requests received by the PCI4510 device from nonlocal bus nodes are accepted.
30	asynReqResource62	RSC	If bit 30 is set to 1 for local bus node number 62, asynchronous requests received by the PCI4510 device from that node are accepted.
29	asynReqResource61	RSC	If bit 29 is set to 1 for local bus node number 61, asynchronous requests received by the PCI4510 device from that node are accepted.
28	asynReqResource60	RSC	If bit 28 is set to 1 for local bus node number 60, asynchronous requests received by the PCI4510 device from that node are accepted.
27	asynReqResource59	RSC	If bit 27 is set to 1 for local bus node number 59, asynchronous requests received by the PCI4510 device from that node are accepted.
26	asynReqResource58	RSC	If bit 26 is set to 1 for local bus node number 58, asynchronous requests received by the PCI4510 device from that node are accepted.
25	asynReqResource57	RSC	If bit 25 is set to 1 for local bus node number 57, asynchronous requests received by the PCI4510 device from that node are accepted.
24	asynReqResource56	RSC	If bit 24 is set to 1 for local bus node number 56, asynchronous requests received by the PCI4510 device from that node are accepted.
23	asynReqResource55	RSC	If bit 23 is set to 1 for local bus node number 55, asynchronous requests received by the PCI4510 device from that node are accepted.
22	asynReqResource54	RSC	If bit 22 is set to 1 for local bus node number 54, asynchronous requests received by the PCI4510 device from that node are accepted.
21	asynReqResource53	RSC	If bit 21 is set to 1 for local bus node number 53, asynchronous requests received by the PCI4510 device from that node are accepted.
20	asynReqResource52	RSC	If bit 20 is set to 1 for local bus node number 52, asynchronous requests received by the PCI4510 device from that node are accepted.
19	asynReqResource51	RSC	If bit 19 is set to 1 for local bus node number 51, asynchronous requests received by the PCI4510 device from that node are accepted.

**Table 8–27. Asynchronous Request Filter High Register Description (Continued)**

BIT	FIELD NAME	TYPE	DESCRIPTION
18	asynReqResource50	RSC	If bit 18 is set to 1 for local bus node number 50, asynchronous requests received by the PCI4510 device from that node are accepted.
17	asynReqResource49	RSC	If bit 17 is set to 1 for local bus node number 49, asynchronous requests received by the PCI4510 device from that node are accepted.
16	asynReqResource48	RSC	If bit 16 is set to 1 for local bus node number 48, asynchronous requests received by the PCI4510 device from that node are accepted.
15	asynReqResource47	RSC	If bit 15 is set to 1 for local bus node number 47, asynchronous requests received by the PCI4510 device from that node are accepted.
14	asynReqResource46	RSC	If bit 14 is set to 1 for local bus node number 46, asynchronous requests received by the PCI4510 device from that node are accepted.
13	asynReqResource45	RSC	If bit 13 is set to 1 for local bus node number 45, asynchronous requests received by the PCI4510 device from that node are accepted.
12	asynReqResource44	RSC	If bit 12 is set to 1 for local bus node number 44, asynchronous requests received by the PCI4510 device from that node are accepted.
11	asynReqResource43	RSC	If bit 11 is set to 1 for local bus node number 43, asynchronous requests received by the PCI4510 device from that node are accepted.
10	asynReqResource42	RSC	If bit 10 is set to 1 for local bus node number 42, asynchronous requests received by the PCI4510 device from that node are accepted.
9	asynReqResource41	RSC	If bit 9 is set to 1 for local bus node number 41, asynchronous requests received by the PCI4510 device from that node are accepted.
8	asynReqResource40	RSC	If bit 8 is set to 1 for local bus node number 40, asynchronous requests received by the PCI4510 device from that node are accepted.
7	asynReqResource39	RSC	If bit 7 is set to 1 for local bus node number 39, asynchronous requests received by the PCI4510 device from that node are accepted.
6	asynReqResource38	RSC	If bit 6 is set to 1 for local bus node number 38, asynchronous requests received by the PCI4510 device from that node are accepted.
5	asynReqResource37	RSC	If bit 5 is set to 1 for local bus node number 37, asynchronous requests received by the PCI4510 device from that node are accepted.
4	asynReqResource36	RSC	If bit 4 is set to 1 for local bus node number 36, asynchronous requests received by the PCI4510 device from that node are accepted.
3	asynReqResource35	RSC	If bit 3 is set to 1 for local bus node number 35, asynchronous requests received by the PCI4510 device from that node are accepted.
2	asynReqResource34	RSC	If bit 2 is set to 1 for local bus node number 34, asynchronous requests received by the PCI4510 device from that node are accepted.
1	asynReqResource33	RSC	If bit 1 is set to 1 for local bus node number 33, asynchronous requests received by the PCI4510 device from that node are accepted.
0	asynReqResource32	RSC	If bit 0 is set to 1 for local bus node number 32, asynchronous requests received by the PCI4510 device from that node are accepted.

### 8.36 Asynchronous Request Filter Low Register

The asynchronous request filter low set/clear register enables asynchronous receive requests on a per-node basis, and handles the lower node IDs. Other than filtering different node IDs, this register behaves identically to the asynchronous request filter high register. See Table 8–28 for a complete description of the register contents.

<b>Bit</b>	<b>31</b>	<b>30</b>	<b>29</b>	<b>28</b>	<b>27</b>	<b>26</b>	<b>25</b>	<b>24</b>	<b>23</b>	<b>22</b>	<b>21</b>	<b>20</b>	<b>19</b>	<b>18</b>	<b>17</b>	<b>16</b>
<b>Name</b>	Asynchronous request filter low															
<b>Type</b>	RSC	RSC	RSC	RSC	RSC	RSC	RSC	RSC	RSC	RSC	RSC	RSC	RSC	RSC	RSC	RSC
<b>Default</b>	0	0	0	0	0	0	0	0	0	0	0	0	0	0	0	0
<b>Bit</b>	<b>15</b>	<b>14</b>	<b>13</b>	<b>12</b>	<b>11</b>	<b>10</b>	<b>9</b>	<b>8</b>	<b>7</b>	<b>6</b>	<b>5</b>	<b>4</b>	<b>3</b>	<b>2</b>	<b>1</b>	<b>0</b>
<b>Name</b>	Asynchronous request filter low															
<b>Type</b>	RSC	RSC	RSC	RSC	RSC	RSC	RSC	RSC	RSC	RSC	RSC	RSC	RSC	RSC	RSC	RSC
<b>Default</b>	0	0	0	0	0	0	0	0	0	0	0	0	0	0	0	0

Register: **Asynchronous request filter low**  
 Offset: 108h set register  
           10Ch clear register  
 Type: Read/Set/Clear  
 Default: 0000 0000h

**Table 8–28. Asynchronous Request Filter Low Register Description**

<b>BIT</b>	<b>FIELD NAME</b>	<b>TYPE</b>	<b>DESCRIPTION</b>
31	asynReqResource31	RSC	If bit 31 is set to 1 for local bus node number 31, asynchronous requests received by the PCI4510 device from that node are accepted.
30	asynReqResource30	RSC	If bit 30 is set to 1 for local bus node number 30, asynchronous requests received by the PCI4510 device from that node are accepted.
29–2	asynReqResourcen	RSC	Bits 29 through 2 (asynReqResourcen, where n = 29, 28, 27, ..., 2) follow the same pattern as bits 31 and 30.
1	asynReqResource1	RSC	If bit 1 is set to 1 for local bus node number 1, asynchronous requests received by the PCI4510 device from that node are accepted.
0	asynReqResource0	RSC	If bit 0 is set to 1 for local bus node number 0, asynchronous requests received by the PCI4510 device from that node are accepted.



## 8.37 Physical Request Filter High Register

The physical request filter high set/clear register enables physical receive requests on a per-node basis, and handles the upper node IDs. When a packet is destined for the physical request context, and the node ID has been compared against the ARRQ registers, then the comparison is done again with this register. If the bit corresponding to the node ID is not set to 1 in this register, then the request is handled by the ARRQ context instead of the physical request context. The node ID comparison is done if the source node is on the same bus as the PCI4510 device. Nonlocal bus-sourced packets are not acknowledged unless bit 31 in this register is set to 1. See Table 8–29 for a complete description of the register contents.

<b>Bit</b>	<b>31</b>	<b>30</b>	<b>29</b>	<b>28</b>	<b>27</b>	<b>26</b>	<b>25</b>	<b>24</b>	<b>23</b>	<b>22</b>	<b>21</b>	<b>20</b>	<b>19</b>	<b>18</b>	<b>17</b>	<b>16</b>
<b>Name</b>	Physical request filter high															
<b>Type</b>	RSC	RSC	RSC	RSC	RSC	RSC	RSC	RSC	RSC	RSC	RSC	RSC	RSC	RSC	RSC	RSC
<b>Default</b>	0	0	0	0	0	0	0	0	0	0	0	0	0	0	0	0
<b>Bit</b>	<b>15</b>	<b>14</b>	<b>13</b>	<b>12</b>	<b>11</b>	<b>10</b>	<b>9</b>	<b>8</b>	<b>7</b>	<b>6</b>	<b>5</b>	<b>4</b>	<b>3</b>	<b>2</b>	<b>1</b>	<b>0</b>
<b>Name</b>	Physical request filter high															
<b>Type</b>	RSC	RSC	RSC	RSC	RSC	RSC	RSC	RSC	RSC	RSC	RSC	RSC	RSC	RSC	RSC	RSC
<b>Default</b>	0	0	0	0	0	0	0	0	0	0	0	0	0	0	0	0

Register: **Physical request filter high**  
 Offset: 110h set register  
 114h clear register  
 Type: Read/Set/Clear  
 Default: 0000 0000h

**Table 8–29. Physical Request Filter High Register Description**

BIT	FIELD NAME	TYPE	DESCRIPTION
31	physReqAllBusses	RSC	If bit 31 is set to 1, all asynchronous requests received by the PCI4510 device from nonlocal bus nodes are accepted. Bit 31 is not cleared by a PRST.
30	physReqResource62	RSC	If bit 30 is set to 1 for local bus node number 62, physical requests received by the PCI4510 device from that node are handled through the physical request context.
29	physReqResource61	RSC	If bit 29 is set to 1 for local bus node number 61, physical requests received by the PCI4510 device from that node are handled through the physical request context.
28	physReqResource60	RSC	If bit 28 is set to 1 for local bus node number 60, physical requests received by the PCI4510 device from that node are handled through the physical request context.
27	physReqResource59	RSC	If bit 27 is set to 1 for local bus node number 59, physical requests received by the PCI4510 device from that node are handled through the physical request context.
26	physReqResource58	RSC	If bit 26 is set to 1 for local bus node number 58, physical requests received by the PCI4510 device from that node are handled through the physical request context.
25	physReqResource57	RSC	If bit 25 is set to 1 for local bus node number 57, physical requests received by the PCI4510 device from that node are handled through the physical request context.
24	physReqResource56	RSC	If bit 24 is set to 1 for local bus node number 56, physical requests received by the PCI4510 device from that node are handled through the physical request context.
23	physReqResource55	RSC	If bit 23 is set to 1 for local bus node number 55, physical requests received by the PCI4510 device from that node are handled through the physical request context.
22	physReqResource54	RSC	If bit 22 is set to 1 for local bus node number 54, physical requests received by the PCI4510 device from that node are handled through the physical request context.
21	physReqResource53	RSC	If bit 21 is set to 1 for local bus node number 53, physical requests received by the PCI4510 device from that node are handled through the physical request context.
20	physReqResource52	RSC	If bit 20 is set to 1 for local bus node number 52, physical requests received by the PCI4510 device from that node are handled through the physical request context.
19	physReqResource51	RSC	If bit 19 is set to 1 for local bus node number 51, physical requests received by the PCI4510 device from that node are handled through the physical request context.

**Table 8–29. Physical Request Filter High Register Description (Continued)**

BIT	FIELD NAME	TYPE	DESCRIPTION
18	physReqResource50	RSC	If bit 18 is set to 1 for local bus node number 50, physical requests received by the PCI4510 device from that node are handled through the physical request context.
17	physReqResource49	RSC	If bit 17 is set to 1 for local bus node number 49, physical requests received by the PCI4510 device from that node are handled through the physical request context.
16	physReqResource48	RSC	If bit 16 is set to 1 for local bus node number 48, physical requests received by the PCI4510 device from that node are handled through the physical request context.
15	physReqResource47	RSC	If bit 15 is set to 1 for local bus node number 47, physical requests received by the PCI4510 device from that node are handled through the physical request context.
14	physReqResource46	RSC	If bit 14 is set to 1 for local bus node number 46, physical requests received by the PCI4510 device from that node are handled through the physical request context.
13	physReqResource45	RSC	If bit 13 is set to 1 for local bus node number 45, physical requests received by the PCI4510 device from that node are handled through the physical request context.
12	physReqResource44	RSC	If bit 12 is set to 1 for local bus node number 44, physical requests received by the PCI4510 device from that node are handled through the physical request context.
11	physReqResource43	RSC	If bit 11 is set to 1 for local bus node number 43, physical requests received by the PCI4510 device from that node are handled through the physical request context.
10	physReqResource42	RSC	If bit 10 is set to 1 for local bus node number 42, physical requests received by the PCI4510 device from that node are handled through the physical request context.
9	physReqResource41	RSC	If bit 9 is set to 1 for local bus node number 41, physical requests received by the PCI4510 device from that node are handled through the physical request context.
8	physReqResource40	RSC	If bit 8 is set to 1 for local bus node number 40, physical requests received by the PCI4510 device from that node are handled through the physical request context.
7	physReqResource39	RSC	If bit 7 is set to 1 for local bus node number 39, physical requests received by the PCI4510 device from that node are handled through the physical request context.
6	physReqResource38	RSC	If bit 6 is set to 1 for local bus node number 38, physical requests received by the PCI4510 device from that node are handled through the physical request context.
5	physReqResource37	RSC	If bit 5 is set to 1 for local bus node number 37, physical requests received by the PCI4510 device from that node are handled through the physical request context.
4	physReqResource36	RSC	If bit 4 is set to 1 for local bus node number 36, physical requests received by the PCI4510 device from that node are handled through the physical request context.
3	physReqResource35	RSC	If bit 3 is set to 1 for local bus node number 35, physical requests received by the PCI4510 device from that node are handled through the physical request context.
2	physReqResource34	RSC	If bit 2 is set to 1 for local bus node number 34, physical requests received by the PCI4510 device from that node are handled through the physical request context.
1	physReqResource33	RSC	If bit 1 is set to 1 for local bus node number 33, physical requests received by the PCI4510 device from that node are handled through the physical request context.
0	physReqResource32	RSC	If bit 0 is set to 1 for local bus node number 32, physical requests received by the PCI4510 device from that node are handled through the physical request context.

## 8.38 Physical Request Filter Low Register

The physical request filter low set/clear register enables physical receive requests on a per-node basis, and handles the lower node IDs. When a packet is destined for the physical request context, and the node ID has been compared against the asynchronous request filter registers, then the node ID comparison is done again with this register. If the bit corresponding to the node ID is not set to 1 in this register, then the request is handled by the asynchronous request context instead of the physical request context. See Table 8–30 for a complete description of the register contents.

<b>Bit</b>	<b>31</b>	<b>30</b>	<b>29</b>	<b>28</b>	<b>27</b>	<b>26</b>	<b>25</b>	<b>24</b>	<b>23</b>	<b>22</b>	<b>21</b>	<b>20</b>	<b>19</b>	<b>18</b>	<b>17</b>	<b>16</b>
<b>Name</b>	Physical request filter low															
<b>Type</b>	RSC	RSC	RSC	RSC	RSC	RSC	RSC	RSC	RSC	RSC	RSC	RSC	RSC	RSC	RSC	RSC
<b>Default</b>	0	0	0	0	0	0	0	0	0	0	0	0	0	0	0	0
<b>Bit</b>	<b>15</b>	<b>14</b>	<b>13</b>	<b>12</b>	<b>11</b>	<b>10</b>	<b>9</b>	<b>8</b>	<b>7</b>	<b>6</b>	<b>5</b>	<b>4</b>	<b>3</b>	<b>2</b>	<b>1</b>	<b>0</b>
<b>Name</b>	Physical request filter low															
<b>Type</b>	RSC	RSC	RSC	RSC	RSC	RSC	RSC	RSC	RSC	RSC	RSC	RSC	RSC	RSC	RSC	RSC
<b>Default</b>	0	0	0	0	0	0	0	0	0	0	0	0	0	0	0	0

Register: **Physical request filter low**  
 Offset: 118h set register  
           11Ch clear register  
 Type: Read/Set/Clear  
 Default: 0000 0000h

**Table 8–30. Physical Request Filter Low Register Description**

<b>BIT</b>	<b>FIELD NAME</b>	<b>TYPE</b>	<b>DESCRIPTION</b>
31	physReqResource31	RSC	If bit 31 is set to 1 for local bus node number 31, physical requests received by the PCI4510 device from that node are handled through the physical request context.
30	physReqResource30	RSC	If bit 30 is set to 1 for local bus node number 30, physical requests received by the PCI4510 device from that node are handled through the physical request context.
29–2	physReqResourcen	RSC	Bits 29 through 2 (physReqResourcen, where n = 29, 28, 27, ..., 2) follow the same pattern as bits 31 and 30.
1	physReqResource1	RSC	If bit 1 is set to 1 for local bus node number 1, physical requests received by the PCI4510 device from that node are handled through the physical request context.
0	physReqResource0	RSC	If bit 0 is set to 1 for local bus node number 0, physical requests received by the PCI4510 device from that node are handled through the physical request context.

## 8.39 Physical Upper Bound Register (Optional Register)

The physical upper bound register is an optional register and is not implemented. This register returns all 0s when read.

<b>Bit</b>	<b>31</b>	<b>30</b>	<b>29</b>	<b>28</b>	<b>27</b>	<b>26</b>	<b>25</b>	<b>24</b>	<b>23</b>	<b>22</b>	<b>21</b>	<b>20</b>	<b>19</b>	<b>18</b>	<b>17</b>	<b>16</b>
<b>Name</b>	Physical upper bound															
<b>Type</b>	R	R	R	R	R	R	R	R	R	R	R	R	R	R	R	R
<b>Default</b>	0	0	0	0	0	0	0	0	0	0	0	0	0	0	0	0
<b>Bit</b>	<b>15</b>	<b>14</b>	<b>13</b>	<b>12</b>	<b>11</b>	<b>10</b>	<b>9</b>	<b>8</b>	<b>7</b>	<b>6</b>	<b>5</b>	<b>4</b>	<b>3</b>	<b>2</b>	<b>1</b>	<b>0</b>
<b>Name</b>	Physical upper bound															
<b>Type</b>	R	R	R	R	R	R	R	R	R	R	R	R	R	R	R	R
<b>Default</b>	0	0	0	0	0	0	0	0	0	0	0	0	0	0	0	0

Register: **Physical upper bound**  
 Offset: 120h  
 Type: Read-only  
 Default: 0000 0000h

## 8.40 Asynchronous Context Control Register

The asynchronous context control set/clear register controls the state and indicates status of the DMA context. See Table 8–31 for a complete description of the register contents.

Bit	31	30	29	28	27	26	25	24	23	22	21	20	19	18	17	16
Name	Asynchronous context control															
Type	R	R	R	R	R	R	R	R	R	R	R	R	R	R	R	R
Default	0	0	0	0	0	0	0	0	0	0	0	0	0	0	0	0
Bit	15	14	13	12	11	10	9	8	7	6	5	4	3	2	1	0
Name	Asynchronous context control															
Type	RSCU	R	R	RSU	RU	RU	R	R	RU	RU	RU	RU	RU	RU	RU	RU
Default	0	0	0	X	0	0	0	0	X	X	X	X	X	X	X	X

Register: **Asynchronous context control**

Offset: 180h set register [ATRQ]  
 184h clear register [ATRQ]  
 1A0h set register [ATRS]  
 1A4h clear register [ATRS]  
 1C0h set register [ARRQ]  
 1C4h clear register [ARRQ]  
 1E0h set register [ARRS]  
 1E4h clear register [ARRS]

Type: Read/Set/Clear/Update, Read/Set/Update, Read/Update, Read-only

Default: 0000 X0XXh

**Table 8–31. Asynchronous Context Control Register Description**

BIT	FIELD NAME	TYPE	DESCRIPTION
31–16	RSVD	R	Reserved. Bits 31–16 return 0s when read.
15	run	RSCU	Bit 15 is set to 1 by software to enable descriptor processing for the context and cleared by software to stop descriptor processing. The PCI4510 device changes this bit only on a system (hardware) or software reset.
14–13	RSVD	R	Reserved. Bits 14 and 13 return 0s when read.
12	wake	RSU	Software sets bit 12 to 1 to cause the PCI4510 device to continue or resume descriptor processing. The PCI4510 device clears this bit on every descriptor fetch.
11	dead	RU	The PCI4510 device sets bit 11 to 1 when it encounters a fatal error, and clears the bit when software clears bit 15 (run). Asynchronous contexts supporting out-of-order pipelining provide unique ContextControl.dead functionality. See Section 7.7 in the <i>1394 Open Host Controller Interface Specification</i> (Release 1.1) for more information.
10	active	RU	The PCI4510 device sets bit 10 to 1 when it is processing descriptors.
9–8	RSVD	R	Reserved. Bits 9 and 8 return 0s when read.
7–5	spd	RU	This field indicates the speed at which a packet was received or transmitted and only contains meaningful information for receive contexts. This field is encoded as: 000 = 100M bits/sec 001 = 200M bits/sec 010 = 400M bits/sec All other values are reserved.
4–0	eventcode	RU	This field holds the acknowledge sent by the link core for this packet or an internally generated error code if the packet was not transferred successfully.

## 8.41 Asynchronous Context Command Pointer Register

The asynchronous context command pointer register contains a pointer to the address of the first descriptor block that the PCI4510 device accesses when software enables the context by setting bit 15 (run) in the asynchronous context control register (see Section 8.40) to 1. See Table 8–32 for a complete description of the register contents.

<b>Bit</b>	31	30	29	28	27	26	25	24	23	22	21	20	19	18	17	16
<b>Name</b>	Asynchronous context command pointer															
<b>Type</b>	RWU	RWU	RWU	RWU	RWU	RWU	RWU	RWU	RWU	RWU	RWU	RWU	RWU	RWU	RWU	RWU
<b>Default</b>	X	X	X	X	X	X	X	X	X	X	X	X	X	X	X	X
<b>Bit</b>	15	14	13	12	11	10	9	8	7	6	5	4	3	2	1	0
<b>Name</b>	Asynchronous context command pointer															
<b>Type</b>	RWU	RWU	RWU	RWU	RWU	RWU	RWU	RWU	RWU	RWU	RWU	RWU	RWU	RWU	RWU	RWU
<b>Default</b>	X	X	X	X	X	X	X	X	X	X	X	X	X	X	X	X

Register: **Asynchronous context command pointer**

Offset: 18Ch [ATRQ]

1ACh [ATRS]

1CCh [ARRQ]

1ECh [ARRS]

Type: Read/Write/Update

Default: XXXX XXXXh

**Table 8–32. Asynchronous Context Command Pointer Register Description**

BIT	FIELD NAME	TYPE	DESCRIPTION
31–4	descriptorAddress	RWU	Contains the upper 28 bits of the address of a 16-byte aligned descriptor block.
3–0	Z	RWU	Indicates the number of contiguous descriptors at the address pointed to by the descriptor address. If Z is 0, then it indicates that the descriptorAddress field (bits 31–4) is not valid.

## 8.42 Isochronous Transmit Context Control Register

The isochronous transmit context control set/clear register controls options, state, and status for the isochronous transmit DMA contexts. The n value in the following register addresses indicates the context number (n = 0, 1, 2, 3, ..., 7). See Table 8–33 for a complete description of the register contents.

Bit	31	30	29	28	27	26	25	24	23	22	21	20	19	18	17	16
Name	Isochronous transmit context control															
Type	RSCU	RSC	RSC	RSC	RSC	RSC	RSC	RSC	RSC	RSC	RSC	RSC	RSC	RSC	RSC	RSC
Default	X	X	X	X	X	X	X	X	X	X	X	X	X	X	X	X
Bit	15	14	13	12	11	10	9	8	7	6	5	4	3	2	1	0
Name	Isochronous transmit context control															
Type	RSC	R	R	RSU	RU	RU	R	R	RU	RU	RU	RU	RU	RU	RU	RU
Default	0	0	0	X	0	0	0	0	X	X	X	X	X	X	X	X

Register: **Isochronous transmit context control**  
 Offset: 200h + (16 \* n) set register  
 204h + (16 \* n) clear register  
 Type: Read/Set/Clear/Update, Read/Set/Clear, Read/Set/Update, Read/Update, Read-only  
 Default: XXXX X0XXh

**Table 8–33. Isochronous Transmit Context Control Register Description**

BIT	FIELD NAME	TYPE	DESCRIPTION
31	cycleMatchEnable	RSCU	When bit 31 is set to 1, processing occurs such that the packet described by the context first descriptor block is transmitted in the cycle whose number is specified in the cycleMatch field (bits 30–16). The cycleMatch field (bits 30–16) must match the low-order two bits of cycleSeconds and the 13-bit cycleCount field in the cycle start packet that is sent or received immediately before isochronous transmission begins. Since the isochronous transmit DMA controller may work ahead, the processing of the first descriptor block may begin slightly in advance of the actual cycle in which the first packet is transmitted.  The effects of this bit, however, are impacted by the values of other bits in this register and are explained in the <i>1394 Open Host Controller Interface Specification</i> . Once the context has become active, hardware clears this bit.
30–16	cycleMatch	RSC	This field contains a 15-bit value, corresponding to the low-order two bits of the isochronous cycle timer register at OHCI offset F0h (see Section 8.34) cycleSeconds field (bits 31–25) and the cycleCount field (bits 24–12). If bit 31 (cycleMatchEnable) is set to 1, then this isochronous transmit DMA context becomes enabled for transmits when the low-order two bits of the isochronous cycle timer register at OHCI offset F0h cycleSeconds field (bits 31–25) and the cycleCount field (bits 24–12) value equal this field (cycleMatch) value.
15	run	RSC	Bit 15 is set to 1 by software to enable descriptor processing for the context and cleared by software to stop descriptor processing. The PCI4510 device changes this bit only on a system (hardware) or software reset.
14–13	RSVD	R	Reserved. Bits 14 and 13 return 0s when read.
12	wake	RSU	Software sets bit 12 to 1 to cause the PCI4510 device to continue or resume descriptor processing. The PCI4510 device clears this bit on every descriptor fetch.
11	dead	RU	The PCI4510 device sets bit 11 to 1 when it encounters a fatal error, and clears the bit when software clears bit 15 (run) to 0.
10	active	RU	The PCI4510 device sets bit 10 to 1 when it is processing descriptors.
9–8	RSVD	R	Reserved. Bits 9 and 8 return 0s when read.
7–5	spd	RU	This field is not meaningful for isochronous transmit contexts.
4–0	event code	RU	Following an OUTPUT_LAST* command, the error code is indicated in this field. Possible values are: ack_complete, evt_descriptor_read, evt_data_read, and evt_unknown.

<sup>T</sup> On an overflow for each running context, the isochronous transmit DMA supports up to 7 cycle skips, when the following are true:

1. Bit 11 (dead) in either the isochronous transmit or receive context control register is set to 1.
2. Bits 4–0 (eventcode field) in either the isochronous transmit or receive context control register is set to evt\_timeout.
3. Bit 24 (unrecoverableError) in the interrupt event register at OHCI offset 80h/84h (see Section 8.21) is set to 1.

### 8.43 Isochronous Transmit Context Command Pointer Register

The isochronous transmit context command pointer register contains a pointer to the address of the first descriptor block that the PCI4510 device accesses when software enables an isochronous transmit context by setting bit 15 (run) in the isochronous transmit context control register (see Section 8.42) to 1. The isochronous transmit DMA context command pointer can be read when a context is active. The n value in the following register addresses indicates the context number (n = 0, 1, 2, 3, ..., 7).

Bit	31	30	29	28	27	26	25	24	23	22	21	20	19	18	17	16
<b>Name</b>	Isochronous transmit context command pointer															
<b>Type</b>	R	R	R	R	R	R	R	R	R	R	R	R	R	R	R	R
<b>Default</b>	X	X	X	X	X	X	X	X	X	X	X	X	X	X	X	X
Bit	15	14	13	12	11	10	9	8	7	6	5	4	3	2	1	0
<b>Name</b>	Isochronous transmit context command pointer															
<b>Type</b>	R	R	R	R	R	R	R	R	R	R	R	R	R	R	R	R
<b>Default</b>	X	X	X	X	X	X	X	X	X	X	X	X	X	X	X	X

Register: **Isochronous transmit context command pointer**  
 Offset: 20Ch + (16 \* n)  
 Type: Read-only  
 Default: XXXX XXXXh

### 8.44 Isochronous Receive Context Control Register

The isochronous receive context control set/clear register controls options, state, and status for the isochronous receive DMA contexts. The n value in the following register addresses indicates the context number (n = 0, 1, 2, 3). See Table 8–34 for a complete description of the register contents.

Bit	31	30	29	28	27	26	25	24	23	22	21	20	19	18	17	16
<b>Name</b>	Isochronous receive context control															
<b>Type</b>	RSC	RSC	RSCU	RSC	RSC	R	R	R	R	R	R	R	R	R	R	R
<b>Default</b>	X	X	X	X	X	0	0	0	0	0	0	0	0	0	0	0
Bit	15	14	13	12	11	10	9	8	7	6	5	4	3	2	1	0
<b>Name</b>	Isochronous receive context control															
<b>Type</b>	RSCU	R	R	RSU	RU	RU	R	R	RU	RU	RU	RU	RU	RU	RU	RU
<b>Default</b>	0	0	0	X	0	0	0	0	X	X	X	X	X	X	X	X

Register: **Isochronous receive context control**  
 Offset: 400h + (32 \* n) set register  
 404h + (32 \* n) clear register  
 Type: Read/Set/Clear/Update, Read/Set/Clear, Read/Set/Update, Read/Update, Read-only  
 Default: XX00 X0XXh

**Table 8–34. Isochronous Receive Context Control Register Description**

BIT	FIELD NAME	TYPE	DESCRIPTION
31	bufferFill	RSC	When bit 31 is set to 1, received packets are placed back-to-back to completely fill each receive buffer. When this bit is cleared, each received packet is placed in a single buffer. If bit 28 (multiChanMode) is set to 1, then this bit must also be set to 1. The value of this bit must not be changed while bit 10 (active) or bit 15 (run) is set to 1.
30	isochHeader	RSC	When bit 30 is set to 1, received isochronous packets include the complete 4-byte isochronous packet header seen by the link layer. The end of the packet is marked with a xferStatus in the first doublet, and a 16-bit timeStamp indicating the time of the most recently received (or sent) cycleStart packet.  When this bit is cleared, the packet header is stripped from received isochronous packets. The packet header, if received, immediately precedes the packet payload. The value of this bit must not be changed while bit 10 (active) or bit 15 (run) is set to 1.

**Table 8–34. Isochronous Receive Context Control Register Description (Continued)**

BIT	FIELD NAME	TYPE	DESCRIPTION
29	cycleMatchEnable	RSCU	When bit 29 is set to 1 and the 13-bit cycleMatch field (bits 24–12) in the isochronous receive context match register (See Section 8.46) matches the 13-bit cycleCount field in the cycleStart packet, the context begins running. The effects of this bit, however, are impacted by the values of other bits in this register. Once the context has become active, hardware clears this bit. The value of this bit must not be changed while bit 10 (active) or bit 15 (run) is set to 1.
28	multiChanMode	RSC	When bit 28 is set to 1, the corresponding isochronous receive DMA context receives packets for all isochronous channels enabled in the isochronous receive channel mask high register at OHCI offset 70h/74h (see Section 8.19) and isochronous receive channel mask low register at OHCI offset 78h/7Ch (see Section 8.20). The isochronous channel number specified in the isochronous receive context match register (see Section 8.46) is ignored.  When this bit is cleared, the isochronous receive DMA context receives packets for the single channel specified in the isochronous receive context match register (see Section 8.46). Only one isochronous receive DMA context may use the isochronous receive channel mask registers (see Sections 8.19, and 8.20). If more than one isochronous receive context control register has this bit set, then the results are undefined. The value of this bit must not be changed while bit 10 (active) or bit 15 (run) is set to 1.
27	dualBufferMode	RSC	When bit 27 is set to 1, receive packets are separated into first and second payload and streamed independently to the firstBuffer series and secondBuffer series as described in Section 10.2.3 in the <i>1394 Open Host Controller Interface Specification</i> . Also, when bit 27 is set to 1, both bits 28 (multiChanMode) and 31 (bufferFill) are cleared to 0. The value of this bit does not change when either bit 10 (active) or bit 15 (run) is set to 1.
26–16	RSVD	R	Reserved. Bits 26–16 return 0s when read.
15	run	RSCU	Bit 15 is set to 1 by software to enable descriptor processing for the context and cleared by software to stop descriptor processing. The PCI4510 device changes this bit only on a system (hardware) or software reset.
14–13	RSVD	R	Reserved. Bits 14 and 13 return 0s when read.
12	wake	RSU	Software sets bit 12 to 1 to cause the PCI4510 device to continue or resume descriptor processing. The PCI4510 device clears this bit on every descriptor fetch.
11	dead	RU	The PCI4510 device sets bit 11 to 1 when it encounters a fatal error, and clears the bit when software clears bit 15 (run).
10	active	RU	The PCI4510 device sets bit 10 to 1 when it is processing descriptors.
9–8	RSVD	R	Reserved. Bits 9 and 8 return 0s when read.
7–5	spd	RU	This field indicates the speed at which the packet was received.  000 = 100M bits/sec 001 = 200M bits/sec 010 = 400M bits/sec  All other values are reserved.
4–0	event code	RU	For bufferFill mode, possible values are: ack_complete, evt_descriptor_read, evt_data_write, and evt_unknown. Packets with data errors (either dataLength mismatches or dataCRC errors) and packets for which a FIFO overrun occurred are backed out. For packet-per-buffer mode, possible values are: ack_complete, ack_data_error, evt_long_packet, evt_overrun, evt_descriptor_read, evt_data_write, and evt_unknown.



## 8.45 Isochronous Receive Context Command Pointer Register

The isochronous receive context command pointer register contains a pointer to the address of the first descriptor block that the PCI4510 device accesses when software enables an isochronous receive context by setting bit 15 (run) in the isochronous receive context control register (see Section 8.44) to 1. The n value in the following register addresses indicates the context number (n = 0, 1, 2, 3).

<b>Bit</b>	<b>31</b>	<b>30</b>	<b>29</b>	<b>28</b>	<b>27</b>	<b>26</b>	<b>25</b>	<b>24</b>	<b>23</b>	<b>22</b>	<b>21</b>	<b>20</b>	<b>19</b>	<b>18</b>	<b>17</b>	<b>16</b>
<b>Name</b>	Isochronous receive context command pointer															
<b>Type</b>	R	R	R	R	R	R	R	R	R	R	R	R	R	R	R	R
<b>Default</b>	X	X	X	X	X	X	X	X	X	X	X	X	X	X	X	X
<b>Bit</b>	<b>15</b>	<b>14</b>	<b>13</b>	<b>12</b>	<b>11</b>	<b>10</b>	<b>9</b>	<b>8</b>	<b>7</b>	<b>6</b>	<b>5</b>	<b>4</b>	<b>3</b>	<b>2</b>	<b>1</b>	<b>0</b>
<b>Name</b>	Isochronous receive context command pointer															
<b>Type</b>	R	R	R	R	R	R	R	R	R	R	R	R	R	R	R	R
<b>Default</b>	X	X	X	X	X	X	X	X	X	X	X	X	X	X	X	X

Register: **Isochronous receive context command pointer**  
 Offset: 40Ch + (32 \* n)  
 Type: Read-only  
 Default: XXXX XXXXh

## 8.46 Isochronous Receive Context Match Register

The isochronous receive context match register starts an isochronous receive context running on a specified cycle number, filters incoming isochronous packets based on tag values, and waits for packets with a specified sync value. The n value in the following register addresses indicates the context number (n = 0, 1, 2, 3). See Table 8–35 for a complete description of the register contents.

Bit	31	30	29	28	27	26	25	24	23	22	21	20	19	18	17	16
<b>Name</b>	Isochronous receive context match															
<b>Type</b>	RW	RW	RW	RW	R	RW	RW	RW	RW	RW	RW	RW	RW	RW	RW	RW
<b>Default</b>	X	X	X	X	0	0	0	X	X	X	X	X	X	X	X	X
Bit	15	14	13	12	11	10	9	8	7	6	5	4	3	2	1	0
<b>Name</b>	Isochronous receive context match															
<b>Type</b>	RW	RW	RW	RW	RW	RW	RW	RW	R	RW	RW	RW	RW	RW	RW	RW
<b>Default</b>	X	X	X	X	X	X	X	X	0	X	X	X	X	X	X	X

Register: **Isochronous receive context match**  
 Offset: 410Ch + (32 \* n)  
 Type: Read/Write, Read-only  
 Default: XXXX XXXXh

**Table 8–35. Isochronous Receive Context Match Register Description**

BIT	FIELD NAME	TYPE	DESCRIPTION
31	tag3	RW	If bit 31 is set to 1, this context matches on isochronous receive packets with a tag field of 11b.
30	tag2	RW	If bit 30 is set to 1, this context matches on isochronous receive packets with a tag field of 10b.
29	tag1	RW	If bit 29 is set to 1, this context matches on isochronous receive packets with a tag field of 01b.
28	tag0	RW	If bit 28 is set to 1, this context matches on isochronous receive packets with a tag field of 00b.
27	RSVD	R	Reserved. Bit 27 returns 0 when read.
26–12	cycleMatch	RW	This field contains a 15-bit value corresponding to the two low-order bits of cycleSeconds and the 13-bit cycleCount field in the cycleStart packet. If cycleMatchEnable (bit 29) in the isochronous receive context control register (see Section 8.44) is set to 1, then this context is enabled for receives when the two low-order bits of the isochronous cycle timer register at OHCI offset F0h (see Section 8.34) cycleSeconds field (bits 31–25) and cycleCount field (bits 24–12) value equal this field (cycleMatch) value.
11–8	sync	RW	This 4-bit field is compared to the sync field of each isochronous packet for this channel when the command descriptor w field is set to 11b.
7	RSVD	R	Reserved. Bit 7 returns 0 when read.
6	tag1SyncFilter	RW	If bit 6 and bit 29 (tag1) are set to 1, then packets with tag 01b are accepted into the context if the two most significant bits of the packet sync field are 00b. Packets with tag values other than 01b are filtered according to bit 28 (tag0), bit 30 (tag2), and bit 31 (tag3) without any additional restrictions. If this bit is cleared, then this context matches on isochronous receive packets as specified in bits 28–31 (tag0–tag3) with no additional restrictions.
5–0	channelNumber	RW	This 6-bit field indicates the isochronous channel number for which this isochronous receive DMA context accepts packets.

## 9 TI Extension Registers

The TI extension base address register provides a method of accessing memory-mapped TI extension registers. See Section 7.9, *TI Extension Base Address Register*, for register bit field details. See Table 9–1 for the TI extension register listing.

**Table 9–1. TI Extension Register Map**

REGISTER NAME	OFFSET
Reserved	00h–A7Fh
Isochronous receive DV enhancement set	A80h
Isochronous receive DV enhancement clear	A84h
Link enhancement control set	A88h
Link enhancement control clear	A8Ch
Isochronous transmit context 0 timestamp offset	A90h
Isochronous transmit context 1 timestamp offset	A94h
Isochronous transmit context 2 timestamp offset	A98h
Isochronous transmit context 3 timestamp offset	A9Ch
Isochronous transmit context 4 timestamp offset	AA0h
Isochronous transmit context 5 timestamp offset	AA4h
Isochronous transmit context 6 timestamp offset	AA8h
Isochronous transmit context 7 timestamp offset	AA8h

### 9.1 DV and MPEG2 Timestamp Enhancements

The DV timestamp enhancements are enabled by bit 8 (`enab_dv_ts`) in the link enhancement control register located at PCI offset F4h and are aliased in TI extension register space at offset A88h (set) and A8Ch (clear).

The DV and MPEG transmit enhancements are enabled separately by bits in the link enhancement control register located in PCI configuration space at PCI offset F4h. The link enhancement control register is also aliased as a set/clear register in TI extension space at offset A88h (set) and A8Ch (clear).

Bit 8 (`enab_dv_ts`) of the link enhancement control register enables DV timestamp support. When enabled, the link calculates a timestamp based on the cycle timer and the timestamp offset register and substitutes it in the SYT field of the CIP once per DV frame.

Bit 10 (`enab_mpeg_ts`) of the link enhancement control register enables MPEG timestamp support. Two MPEG time stamp modes are supported. The default mode calculates an initial delta that is added to the calculated timestamp in addition to a user-defined offset. The initial offset is calculated as the difference in the intended transmit cycle count and the cycle count field of the timestamp in the first TSP of the MPEG2 stream. The use of the initial delta can be controlled by bit 31 (`DisableInitialOffset`) in the timestamp offset register (see Section 9.5).

The MPEG2 timestamp enhancements are enabled by bit 10 (`enab_mpeg_ts`) in the link enhancement control register located at PCI offset F4h and aliased in TI extension register space at offset A88h (set) and A8Ch (clear).

When bit 10 (`enab_mpeg_ts`) is set to 1, the hardware applies the timestamp enhancements to isochronous transmit packets that have the tag field equal to 01b in the isochronous packet header and a FMT field equal to 10h.

## 9.2 Isochronous Receive Digital Video Enhancements

The DV frame sync and branch enhancement provides a mechanism in buffer-fill mode to synchronize 1394 DV data that is received in the correct order to DV frame-sized data buffers described by several INPUT\_MORE descriptors (see *1394 Open Host Controller Interface Specification*, Release 1.1). This is accomplished by waiting for the start-of-frame packet in a DV stream before transferring the received isochronous stream into the memory buffer described by the INPUT\_MORE descriptors. This can improve the DV capture application performance by reducing the amount of processing overhead required to strip the CIP header and copy the received packets into frame-sized buffers.

The start of a DV frame is represented in the 1394 packet as a 16-bit pattern of 1FX7h (first byte 1Fh and second byte X7h) received as the first two bytes of the third quadlet in a DV isochronous packet.

## 9.3 Isochronous Receive Digital Video Enhancements Register

The isochronous receive digital video enhancements register enables the DV enhancements in the PCI4510 device. The bits in this register may only be modified when both the active (bit 10) and run (bit 15) bits of the corresponding context control register are 0. See Table 9–2 for a complete description of the register contents.

Bit	31	30	29	28	27	26	25	24	23	22	21	20	19	18	17	16
<b>Name</b>	Isochronous receive digital video enhancements															
<b>Type</b>	R	R	R	R	R	R	R	R	R	R	R	R	R	R	R	R
<b>Default</b>	0	0	0	0	0	0	0	0	0	0	0	0	0	0	0	0
Bit	15	14	13	12	11	10	9	8	7	6	5	4	3	2	1	0
<b>Name</b>	Isochronous receive digital video enhancements															
<b>Type</b>	R	R	RSC	RSC	R	R	RSC	RSC	R	R	RSC	RSC	R	R	RSC	RSC
<b>Default</b>	0	0	0	0	0	0	0	0	0	0	0	0	0	0	0	0

Register: **Isochronous receive digital video enhancements**

Offset: A80h set register

A84h clear register

Type: Read/Set/Clear, Read-only

Default: 0000 0000h

**Table 9–2. Isochronous Receive Digital Video Enhancements Register Description**

BIT	FIELD NAME	TYPE	DESCRIPTION
31–14	RSVD	R	Reserved. Bits 31–14 return 0s when read.
13	DV_Branch3	RSC	When bit 13 is set to 1, the isochronous receive context 3 synchronizes reception to the DV frame start tag in bufferfill mode if input_more.b = 01b, and jumps to the descriptor pointed to by frameBranch if a DV frame start tag is received out of place. This bit is only interpreted when bit 12 (CIP_Strip3) is set to 1 and bit 30 (isochHeader) in the isochronous receive context control register at OHCI offset 460h/464h (see Section 8.44) is cleared to 0.
12	CIP_Strip3	RSC	When bit 12 is set to 1, the isochronous receive context 3 strips the first two quadlets of payload. This bit is only interpreted when bit 30 (isochHeader) in the isochronous receive context control register at OHCI offset 460h/464h (see Section 8.44) is cleared to 0.
11–10	RSVD	R	Reserved. Bits 11 and 10 return 0s when read.
9	DV_Branch2	RSC	When bit 9 is set to 1, the isochronous receive context 2 synchronizes reception to the DV frame start tag in bufferfill mode if input_more.b = 01b, and jumps to the descriptor pointed to by frameBranch if a DV frame start tag is received out of place. This bit is only interpreted when bit 8 (CIP_Strip2) is set to 1 and bit 30 (isochHeader) in the isochronous receive context control register at OHCI offset 440h/444h (see Section 8.44) is cleared to 0.
8	CIP_Strip2	RSC	When bit 8 is set to 1, the isochronous receive context 2 strips the first two quadlets of payload. This bit is only interpreted when bit 30 (isochHeader) in the isochronous receive context control register at OHCI offset 440h/444h (see Section 8.44) is cleared to 0.

**Table 9–2. Isochronous Receive Digital Video Enhancements Register Description (Continued)**

BIT	FIELD NAME	TYPE	DESCRIPTION
7–6	RSVD	R	Reserved. Bits 7 and 6 return 0s when read.
5	DV_Branch1	RSC	When bit 5 is set to 1, the isochronous receive context 1 synchronizes reception to the DV frame start tag in bufferfill mode if input_more.b = 01b, and jumps to the descriptor pointed to by frameBranch if a DV frame start tag is received out of place. This bit is only interpreted when bit 4 (CIP_Strip1) is set to 1 and bit 30 (isochHeader) in the isochronous receive context control register at OHCI offset 420h/424h (see Section 8.44) is cleared to 0.
4	CIP_Strip1	RSC	When bit 4 is set to 1, the isochronous receive context 1 strips the first two quadlets of payload. This bit is only interpreted when bit 30 (isochHeader) in the isochronous receive context control register at OHCI offset 420h/424h (see Section 8.44) is cleared to 0.
3–2	RSVD	R	Reserved. Bits 3 and 2 return 0s when read.
1	DV_Branch0	RSC	When bit 1 is set to 1, the isochronous receive context 0 synchronizes reception to the DV frame start tag in bufferfill mode if input_more.b = 01b and jumps to the descriptor pointed to by frameBranch if a DV frame start tag is received out of place. This bit is only interpreted when bit 0 (CIP_Strip0) is set to 1 and bit 30 (isochHeader) in the isochronous receive context control register at OHCI offset 400h/404h (see Section 8.44) is cleared to 0.
0	CIP_Strip0	RSC	When bit 0 is set to 1, the isochronous receive context 0 strips the first two quadlets of payload. This bit is only interpreted when bit 30 (isochHeader) in the isochronous receive context control register at OHCI offset 400h/404h (see Section 8.44) is cleared to 0.

## 9.4 Link Enhancement Register

This register is a memory-mapped set/clear register that is an alias of the link enhancement control register at PCI offset F4h. These bits may be initialized by software. Some of the bits may also be initialized by a serial EEPROM, if one is present, as noted in the bit descriptions below. If the bits are to be initialized by software, then the bits must be initialized prior to setting bit 19 (LPS) in the host controller control register at OHCI offset 50h/54h (see Section 8.16). See Table 9–3 for a complete description of the register contents.

Bit	31	30	29	28	27	26	25	24	23	22	21	20	19	18	17	16
<b>Name</b>	Link enhancement															
<b>Type</b>	R	R	R	R	R	R	R	R	R	R	R	R	R	R	R	R
<b>Default</b>	0	0	0	0	0	0	0	0	0	0	0	0	0	0	0	0
Bit	15	14	13	12	11	10	9	8	7	6	5	4	3	2	1	0
<b>Name</b>	Link enhancement															
<b>Type</b>	RSC	R	RSC	RSC	R	RSC	R	RSC	RSC	R	R	R	R	R	RSC	R
<b>Default</b>	0	0	0	1	0	0	0	0	0	0	0	0	0	0	0	0

Register: **Link enhancement**  
 Offset: A88h set register  
 A8Ch clear register  
 Type: Read/Set/Clear, Read-only  
 Default: 0000 0000h

**Table 9–3. Link Enhancement Register Description**

BIT	FIELD NAME	TYPE	DESCRIPTION
31–16	RSVD	R	Reserved. Bits 31–16 return 0s when read.
15	dis_at_pipeline	RSC	Disable AT pipelining. When bit 15 is set to 1, out-of-order AT pipelining is disabled.
14	RSVD	R	Reserved.
13–12	atx_thresh	RSC	<p>This field sets the initial AT threshold value, which is used until the AT FIFO is underrun. When the PCI4510 device retries the packet, it uses a 2K-byte threshold, resulting in a store-and-forward operation.</p> <p>00 = Threshold ~ 2K bytes resulting in a store-and-forward operation            01 = Threshold ~ 1.7K bytes (default)            10 = Threshold ~ 1K bytes            11 = Threshold ~ 512 bytes</p> <p>These bits fine-tune the asynchronous transmit threshold. For most applications the 1.7K-byte threshold is optimal. Changing this value may increase or decrease the 1394 latency depending on the average PCI bus latency.</p> <p>Setting the AT threshold to 1.7K, 1K, or 512 bytes results in data being transmitted at these thresholds or when an entire packet has been checked into the FIFO. If the packet to be transmitted is larger than the AT threshold, then the remaining data must be received before the AT FIFO is emptied; otherwise, an underrun condition occurs, resulting in a packet error at the receiving node. As a result, the link then commences store-and-forward operation. Wait until it has the complete packet in the FIFO before retransmitting it on the second attempt, to ensure delivery.</p> <p>An AT threshold of 2K results in store-and-forward operation, which means that asynchronous data will not be transmitted until an end-of-packet token is received. Restated, setting the AT threshold to 2K results in only complete packets being transmitted.</p> <p>Note that this device always uses store-and-forward when the asynchronous transmit retries register at OHCI offset 08h (see Section 8.3) is cleared.</p>
11	RSVD	R	Reserved. Bit 11 returns 0 when read.
10	enab_mpeg_ts	RSC	Enable MPEG timestamp enhancements. When bit 10 is set to 1, the enhancement is enabled for MPEG transmit streams (FMT = 20h).
9	RSVD	R	Reserved. Bit 9 returns 0 when read.
8	enab_dv_ts	RSC	Enable DV CIP timestamp enhancement. When bit 8 is set to 1, the enhancement is enabled for DV CIP transmit streams (FMT = 00h).

**Table 9–3. Link Enhancement Register Description (Continued)**

BIT	FIELD NAME	TYPE	DESCRIPTION
7	enab_unfair	RSC	Enable asynchronous priority requests. OHCI-Lynx™ compatible. Setting bit 7 to 1 enables the link to respond to requests with priority arbitration. It is recommended that this bit be set to 1.
6	RSVD	R	This bit is not assigned in the PCI4510 follow-on products, since this bit location loaded by the serial EEPROM from the enhancements field corresponds to bit 23 (programPhyEnable) in the host controller control register at OHCI offset 50h/54h (see Section 8.16).
5–2	RSVD	R	Reserved. Bits 5–2 return 0s when read.
1	enab_accel	RSC	Enable acceleration enhancements. OHCI-Lynx™ compatible. When bit 1 is set to 1, the PHY layer is notified that the link supports the IEEE Std 1394a-2000 acceleration enhancements, that is, ack-accelerated, fly-by concatenation, etc. It is recommended that this bit be set to 1.
0	RSVD	R	Reserved. Bit 0 returns 0 when read.

## 9.5 Timestamp Offset Register

The value of this register is added as an offset to the cycle timer value when using the MPEG, DV, and CIP enhancements. A timestamp offset register is implemented per isochronous transmit context. The n value following the offset indicates the context number (n = 0, 1, 2, 3, ..., 7). These registers are programmed by software as appropriate. See Table 9–4 for a complete description of the register contents.

Bit	31	30	29	28	27	26	25	24	23	22	21	20	19	18	17	16
<b>Name</b>	Timestamp offset															
<b>Type</b>	RW	R	R	R	R	R	R	RW	RW	RW	RW	RW	RW	RW	RW	RW
<b>Default</b>	0	0	0	0	0	0	0	0	0	0	0	0	0	0	0	0
Bit	15	14	13	12	11	10	9	8	7	6	5	4	3	2	1	0
<b>Name</b>	Timestamp offset															
<b>Type</b>	RW	RW	RW	RW	RW	RW	RW	RW	RW	RW	RW	RW	RW	RW	RW	RW
<b>Default</b>	0	0	0	0	0	0	0	0	0	0	0	0	0	0	0	0

Register: **Timestamp offset**  
 Offset: A90h + (4\*n)  
 Type: Read/Write, Read-only  
 Default: 0000 0000h

**Table 9–4. Timestamp Offset Register Description**

BIT	FIELD NAME	TYPE	DESCRIPTION
31	DisableInitialOffset	RW	Bit 31 disables the use of the initial timestamp offset when the MPEG2 enhancements are enabled. A value of 0 indicates the use of the initial offset, a value of 1 indicates that the initial offset must not be applied to the calculated timestamp. This bit has no meaning for the DV timestamp enhancements.
30–25	RSVD	R	Reserved. Bits 30–25 return 0s when read.
24–12	CycleCount	RW	This field adds an offset to the cycle count field in the timestamp when the DV or MPEG2 enhancements are enabled. The cycle count field is incremented modulo 8000; therefore, values in this field must be limited between 0 and 7999.
11–0	CycleOffset	RW	This field adds an offset to the cycle offset field in the timestamp when the DV or MPEG2 enhancements are enabled. The cycle offset field is incremented modulo 3072; therefore, values in this field must be limited between 0 and 3071.





## 10 PHY Register Configuration

There are 16 accessible internal registers in the PCI4510 device. The configuration of the registers at addresses 0h through 7h (the base registers) is fixed, whereas the configuration of the registers at addresses 8h through Fh (the paged registers) is dependent upon which one of eight pages, numbered 0h through 7h, is currently selected. The selected page is set in base register 7h.

### 10.1 Base Registers

Table 10–1 shows the configuration of the base registers, and Table 10–2 shows the corresponding field descriptions. The base register field definitions are unaffected by the selected page number.

A reserved register or register field (marked as Reserved in the following register configuration tables) is read as 0, but is subject to future usage. All registers in address pages 2 through 6 are reserved.

**Table 10–1. Base Register Configuration**

ADDRESS	BIT POSITION							
	0	1	2	3	4	5	6	7
0000	Physical ID						R	CPS
0001	RHB	IBR	Gap_Count					
0010	Extended (111b)			Reserved	Total_Ports (0010b)			
0011	Max_Speed (010b)			Reserved	Delay (0000b)			
0100	LCtrl	C	Jitter (000b)			Pwr_Class		
0101	Watchdog	ISBR	Loop	Pwr_fail	Timeout	Port_event	Enab_accel	Enab_multi
0110	Reserved							
0111	Page_Select			Reserved	Port_Select			

**Table 10–2. Base Register Field Descriptions**

FIELD	SIZE	TYPE	DESCRIPTION
Physical ID	6	R	This field contains the physical address ID of this node determined during self-ID. The physical ID is invalid after a bus reset until self-ID has completed as indicated by an unsolicited register-0 status transfer.
R	1	R	Root. This bit indicates that this node is the root node. The R bit is cleared to 0 by bus reset and is set to 1 during tree-ID if this node becomes root.
CPS	1	R	Cable-power-status. This bit indicates the state of the CPS input terminal. The CPS terminal is normally tied to serial bus cable power through a 400-kΩ resistor. A 0 in this bit indicates that the cable power voltage has dropped below its threshold for ensured reliable operation.
RHB	1	R/W	Root-holdoff bit. This bit instructs the PHY layer to attempt to become root after the next bus reset. The RHB bit is cleared to 0 by a system (hardware) reset and is unaffected by a bus reset.
IBR	1	R/W	Initiate bus reset. This bit instructs the PHY layer to initiate a long (166 μs) bus reset at the next opportunity. Any receive or transmit operation in progress when this bit is set completes before the bus reset is initiated. The IBR bit is cleared to 0 after a system (hardware) reset or a bus reset.
Gap_Count	6	R/W	Arbitration gap count. This value sets the subaction (fair) gap, arb-reset gap, and arb-delay times. The gap count can be set either by a write to the register, or by reception or transmission of a PHY_CONFIG packet. The gap count is reset to 3Fh by system (hardware) reset or after two consecutive bus resets without an intervening write to the gap count register (either by a write to the PHY register or by a PHY_CONFIG packet).
Extended	3	R	Extended register definition. For the PCI4510 device, this field is 111b, indicating that the extended register set is implemented.
Total_Ports	4	R	Number of ports. This field indicates the number of ports implemented in the PHY layer. For the PCI4510 device this field is 2.
Max_Speed	3	R	PHY speed capability. For the PCI4510 PHY layer this field is 010b, indicating S400 speed capability.
Delay	4	R	PHY repeater data delay. This field indicates the worst case repeater data delay of the PHY layer, expressed as $144+(\text{delay} \times 20)$ ns. For the PCI4510 device this field is 0.
LCtrl	1	R/W	Link-active status control. This bit controls the active status of the LLC as indicated during self-ID. The logical AND of this bit and the LPS active status is replicated in the L field (bit 9) of the self-ID packet. The LLC is considered active only if both the LPS input is active and the LCtrl bit is set.  The LCtrl bit provides a software controllable means to indicate the LLC active/status in lieu of using the LPS input.  The LCtrl bit is set to 1 by a system (hardware) reset and is unaffected by a bus reset.  NOTE: The state of the PHY-LLC interface is controlled solely by the LPS input, regardless of the state of the LCtrl bit. If the PHY-LLC interface is operational as determined by the LPS input being active, received packets and status information continue to be presented on the interface, and any requests indicated on the LREQ input are processed, even if the LCtrl bit is cleared to 0.
C	1	R/W	Contender status. This bit indicates that this node is a contender for the bus or isochronous resource manager. This bit is replicated in the c field (bit 20) of the self-ID packet.
Jitter	3	R	PHY repeater jitter. This field indicates the worst case difference between the fastest and slowest repeater data delay, expressed as $(\text{Jitter}+1) \times 20$ ns. For the PCI4510 device, this field is 0.
Pwr_Class	3	R/W	Node power class. This field indicates this node power consumption and source characteristics and is replicated in the pwr field (bits 21–23) of the self-ID packet. This field is reset to the state specified by the PC0–PC2 input terminals upon a system (hardware) reset and is unaffected by a bus reset. See Table 10–9.
Watchdog	1	R/W	Watchdog enable. This bit, if set to 1, enables the port event interrupt (Port_event) bit to be set whenever resume operations begin on any port. This bit is cleared to 0 by system (hardware) reset and is unaffected by bus reset.

**Table 10–2. Base Register Field Descriptions (Continued)**

FIELD	SIZE	TYPE	DESCRIPTION
ISBR	1	R/W	Initiate short arbitrated bus reset. This bit, if set to 1, instructs the PHY layer to initiate a short (1.3 $\mu$ s) arbitrated bus reset at the next opportunity. This bit is cleared to 0 by a bus reset.  NOTE: Legacy IEEE Std 1394-1995 compliant PHY layers can not be capable of performing short bus resets. Therefore, initiation of a short bus reset in a network that contains such a legacy device results in a long bus reset being performed.
Loop	1	R/W	Loop detect. This bit is set to 1 when the arbitration controller times out during tree-ID start and may indicate that the bus is configured in a loop. This bit is cleared to 0 by system (hardware) reset or by writing a 1 to this register bit.  If the loop and watchdog bits are both set and the LLC is or becomes inactive, the PHY layer activates the LLC to service the interrupt.  NOTE: If the network is configured in a loop, only those nodes which are part of the loop generate a configuration-timeout interrupt. All other nodes instead time out waiting for the tree-ID and/or self-ID process to complete and then generate a state time-out interrupt and bus-reset.
Pwr_fail	1	R/W	Cable power failure detect. This bit is set to 1 whenever the CPS input transitions from high to low indicating that cable power may be too low for reliable operation. This bit is cleared to 0 by system (hardware) reset or by writing a 1 to this register bit.
Timeout	1	R/W	State time-out interrupt. This bit indicates that a state time-out has occurred (which also causes a bus reset to occur). This bit is cleared to 0 by system (hardware) reset or by writing a 1 to this register bit.
Port_event	1	R/W	Port event detect. This bit is set to 1 upon a change in the bias (unless disabled) connected, disabled, or fault bits for any port for which the port interrupt enable (Int_enable) bit is set. Additionally, if the watchdog bit is set, the Port_event bit is set to 1 at the start of resume operations on any port. This bit is cleared to 0 by system (hardware) reset or by writing a 1 to this register bit.
Enab_accel	1	R/W	Enable accelerated arbitration. This bit enables the PHY layer to perform the various arbitration acceleration enhancements defined in IEEE Std 1394a-2000 (ACK-accelerated arbitration, asynchronous fly-by concatenation, and isochronous fly-by concatenation). This bit is cleared to 0 by system (hardware) reset and is unaffected by bus reset.
Enab_multi	1	R/W	Enable multispeed concatenated packets. This bit enables the PHY layer to transmit concatenated packets of differing speeds in accordance with the protocols defined in IEEE Std 1394a-2000. This bit is cleared to 0 by system (hardware) reset and is unaffected by bus reset.
Page_Select	3	R/W	Page_Select. This field selects the register page to use when accessing register addresses 8 through 15. This field is cleared to 0 by a system (hardware) reset and is unaffected by bus reset.
Port_Select	4	R/W	Port_Select. This field selects the port when accessing per-port status or control (for example, when one of the port status/control registers is accessed in page 0). Ports are numbered starting at 0. This field is cleared to 0 by system (hardware) reset and is unaffected by bus reset.

## 10.2 Port Status Register

The port status page provides access to configuration and status information for each of the ports. The port is selected by writing 0 to the Page\_Select field and the desired port number to the Port\_Select field in base register 7. Table 10–3 shows the configuration of the port status page registers and Table 10–4 shows the corresponding field descriptions. If the selected port is not implemented, all registers in the port status page are read as 0.

**Table 10–3. Page 0 (Port Status) Register Configuration**

ADDRESS	BIT POSITION							
	0	1	2	3	4	5	6	7
1000	AStat		BStat		Ch	Con	Bias	Dis
1001	Peer_Speed			Int_enable	Fault	Reserved		
1010	Reserved							
1011	Reserved							
1100	Reserved							
1101	Reserved							
1110	Reserved							
1111	Reserved							

**Table 10–4. Page 0 (Port Status) Register Field Descriptions**

FIELD	SIZE	TYPE	DESCRIPTION										
AStat	2	R	TPA line state. This field indicates the TPA line state of the selected port, encoded as follows: <table border="0"> <tr> <td><u>Code</u></td> <td><u>Arb Value</u></td> </tr> <tr> <td>11</td> <td>Z</td> </tr> <tr> <td>10</td> <td>0</td> </tr> <tr> <td>01</td> <td>1</td> </tr> <tr> <td>00</td> <td>invalid</td> </tr> </table>	<u>Code</u>	<u>Arb Value</u>	11	Z	10	0	01	1	00	invalid
<u>Code</u>	<u>Arb Value</u>												
11	Z												
10	0												
01	1												
00	invalid												
BStat	2	R	TPB line state. This field indicates the TPB line state of the selected port. This field has the same encoding as the AStat field.										
Ch	1	R	Child/parent status. A 1 indicates that the selected port is a child port. A 0 indicates that the selected port is the parent port. A disconnected, disabled, or suspended port is reported as a child port. The Ch bit is invalid after a bus reset until tree-ID has completed.										
Con	1	R	Debounce port connection status. This bit indicates that the selected port is connected. The connection must be stable for the debounce time of approximately 341 ms for the con bit to be set to 1. The Con bit is cleared to 0 by system (hardware) reset and is unaffected by bus reset.  NOTE: The Con bit indicates that the port is physically connected to a peer PHY device, but the port is not necessarily active.										
Bias	1	R	Debounce incoming cable bias status. A 1 indicates that the selected port is detecting incoming cable bias. The incoming cable bias must be stable for the debounce time of 52 μs for the bias bit to be set to 1.										
Dis	1	RW	Port disabled control. If the dis bit is set to 1, the selected port is disabled. The dis bit is cleared to 0 by system (hardware) reset (all ports are enabled for normal operation following system (hardware) reset). The dis bit is not affected by bus reset.										
Peer_Speed	3	R	Port peer speed. This field indicates the highest speed capability of the peer PHY device connected to the selected port, encoded as follows: <table border="0"> <tr> <td><u>Code</u></td> <td><u>Peer Speed</u></td> </tr> <tr> <td>000</td> <td>S100</td> </tr> <tr> <td>001</td> <td>S200</td> </tr> <tr> <td>010</td> <td>S400</td> </tr> <tr> <td>011–111</td> <td>invalid</td> </tr> </table> The Peer_Speed field is invalid after a bus reset until self-ID has completed.  NOTE: Peer speed codes higher than 010b (S400) are defined in IEEE Std 1394a-2000. However, the PCI4510 device is only capable of detecting peer speeds up to S400.	<u>Code</u>	<u>Peer Speed</u>	000	S100	001	S200	010	S400	011–111	invalid
<u>Code</u>	<u>Peer Speed</u>												
000	S100												
001	S200												
010	S400												
011–111	invalid												

**Table 10–4. Page 0 (Port Status) Register Field Descriptions (Continued)**

FIELD	SIZE	TYPE	DESCRIPTION
Int_enable	1	RW	Port event interrupt enable. When the Int_enable bit is set to 1, a port event on the selected port sets the port event interrupt (Port_event) bit and notifies the link. This bit is cleared to 0 by a system (hardware) reset and is unaffected by bus reset.
Fault	1	RW	Fault. This bit indicates that a resume-fault or suspend-fault has occurred on the selected port, and that the port is in the suspended state. A resume-fault occurs when a resuming port fails to detect incoming cable bias from its attached peer. A suspend-fault occurs when a suspending port continues to detect incoming cable bias from its attached peer. Writing 1 to this bit clears the fault bit to 0. This bit is cleared to 0 by system (hardware) reset and is unaffected by bus reset.

### 10.3 Vendor Identification Register

The vendor identification page identifies the vendor/manufacturer and compliance level. The page is selected by writing 1 to the Page\_Select field in base register 7. Table 10–5 shows the configuration of the vendor identification page, and Table 10–6 shows the corresponding field descriptions.

**Table 10–5. Page 1 (Vendor ID) Register Configuration**

ADDRESS	BIT POSITION							
	0	1	2	3	4	5	6	7
1000	Compliance							
1001	Reserved							
1010	Vendor_ID[0]							
1011	Vendor_ID[1]							
1100	Vendor_ID[2]							
1101	Product_ID[0]							
1110	Product_ID[1]							
1111	Product_ID[2]							

**Table 10–6. Page 1 (Vendor ID) Register Field Descriptions**

FIELD	SIZE	TYPE	DESCRIPTION
Compliance	8	R	Compliance level. For the PCI4510 device this field is 01h, indicating compliance with IEEE Std 1394a-2000.
Vendor_ID	24	R	Manufacturer's organizationally unique identifier (OUI). For the PCI4510 device this field is 08 0028h (Texas Instruments) (the MSB is at register address 1010b).
Product_ID	24	R	Product identifier. For the PCI4510 device this field is 42 4499h (the MSB is at register address 1101b).

## 10.4 Vendor-Dependent Register

The vendor-dependent page provides access to the special control features of the PCI4510 device, as well as to configuration and status information used in manufacturing test and debug. This page is selected by writing 7 to the Page\_Select field in base register 7. Table 10–7 shows the configuration of the vendor-dependent page, and Table 10–8 shows the corresponding field descriptions.

**Table 10–7. Page 7 (Vendor-Dependent) Register Configuration**

ADDRESS	BIT POSITION							
	0	1	2	3	4	5	6	7
1000	NPA	Reserved					Link_Speed	
1001	Reserved for test							
1010	Reserved for test							
1011	Reserved for test							
1100	Reserved for test							
1101	Reserved for test							
1110	Reserved for test							
1111	Reserved for test							

**Table 10–8. Page 7 (Vendor-Dependent) Register Field Descriptions**

FIELD	SIZE	TYPE	DESCRIPTION										
NPA	1	RW	Null-packet actions flag. This bit instructs the PHY layer to not clear fair and priority requests when a null packet is received with arbitration acceleration enabled. If this bit is set to 1, fair and priority requests are cleared only when a packet of more than 8 bits is received; ACK packets (exactly 8 data bits), null packets (no data bits), and malformed packets (less than 8 data bits) do not clear fair and priority requests. If this bit is cleared to 0, fair and priority requests are cleared when any non-ACK packet is received, including null packets or malformed packets of less than 8 bits. This bit is cleared to 0 by system (hardware) reset and is unaffected by bus reset.										
Link_Speed	2	RW	Link speed. This field indicates the top speed capability of the attached LLC. Encoding is as follows: <table border="0" style="margin-left: 20px;"> <tr> <td style="text-align: right;"><u>Code</u></td> <td style="text-align: left;"><u>Speed</u></td> </tr> <tr> <td style="text-align: right;">00</td> <td>S100</td> </tr> <tr> <td style="text-align: right;">01</td> <td>S200</td> </tr> <tr> <td style="text-align: right;">10</td> <td>S400</td> </tr> <tr> <td style="text-align: right;">11</td> <td>illegal</td> </tr> </table> <p>This field is replicated in the sp field of the self-ID packet to indicate the speed capability of the node (PHY and LLC in combination). However, this field does not affect the PHY speed capability indicated to peer PHYs during self-ID; the PCI4510 PHY layer identifies itself as S400 capable to its peers regardless of the value in this field. This field is set to 10b (S400) by system (hardware) reset and is unaffected by bus reset.</p>	<u>Code</u>	<u>Speed</u>	00	S100	01	S200	10	S400	11	illegal
<u>Code</u>	<u>Speed</u>												
00	S100												
01	S200												
10	S400												
11	illegal												

## 10.5 Power-Class Programming

The PC0–PC2 terminals are programmed to set the default value of the power-class indicated in the pwr field (bits 21–23) of the transmitted self-ID packet. Table 10–9 shows the descriptions of the various power classes. The default power-class value is loaded following a system (hardware) reset, but is overridden by any value subsequently loaded into the Pwr\_Class field in register 4.

**Table 10–9. Power Class Descriptions**

PC0–PC2	DESCRIPTION
000	Node does not need power and does not repeat power.
001	Node is self-powered and provides a minimum of 15 W to the bus.
010	Node is self-powered and provides a minimum of 30 W to the bus.
011	Node is self-powered and provides a minimum of 45 W to the bus.
100	Node may be powered from the bus and is using up to 3 W. No additional power is needed to enable the link.
101	Reserved
110	Node is powered from the bus and uses up to 3 W. An additional 3 W is needed to enable the link.
111	Node is powered from the bus and uses up to 3 W. An additional 7 W is needed to enable the link.





## 11 Electrical Characteristics

### 11.1 Absolute Maximum Ratings Over Operating Temperature Ranges†

Supply voltage range:	VR_PORT	.....	-0.2 V to 2.2 V
	ANALOGV <sub>CC</sub>	.....	-0.3 V to 4 V
	V <sub>CC</sub>	.....	-0.3 V to 4 V
	PLL <sub>V</sub> <sub>CC</sub>	.....	-0.3 V to 4 V
	V <sub>CCCB</sub>	.....	-0.5 V to 5.5 V
	V <sub>CCP</sub>	.....	-0.5 V to 5.5 V
Clamping voltage range for V <sub>CCP</sub> and V <sub>CCCB</sub>		.....	-0.5 to 6 V
Input voltage range for PCI, V <sub>I</sub> , CardBus, PHY, and Miscellaneous		.....	-0.5 to V <sub>CC</sub> + 0.5 V
Output voltage range for PCI, V <sub>O</sub> , CardBus, PHY, and Miscellaneous		.....	-0.5 to V <sub>CC</sub> + 0.5 V
Input clamp current, I <sub>I<sub>K</sub></sub> (V <sub>I</sub> < 0 or V <sub>I</sub> > V <sub>CC</sub> ) (see Note 1)		.....	±20 mA
Output clamp current, I <sub>O<sub>K</sub></sub> (V <sub>O</sub> < 0 or V <sub>O</sub> > V <sub>CC</sub> ) (see Note 2)		.....	±20 mA
Operating free-air temperature, T <sub>A</sub>		.....	0°C to 70°C
Storage temperature range, T <sub>stg</sub>		.....	-65°C to 150°C
Virtual junction temperature, T <sub>J</sub>		.....	150°C

† Stresses beyond those listed under absolute maximum ratings may cause permanent damage to the device. These are stress ratings only, and functional operation of the device at these or any other conditions beyond those indicated under recommended operating conditions is not implied. Exposure to absolute-maximum-rated conditions for extended periods may affect device reliability.

- NOTES:
1. Applies for external input and bidirectional buffers. V<sub>I</sub> > V<sub>CC</sub> does not apply to fail-safe terminals. PCI terminals and miscellaneous terminals are measured with respect to V<sub>CCP</sub> instead of V<sub>CC</sub>. PC Card terminals are measured with respect to V<sub>CCCB</sub>. The limit specified applies for a dc condition.
  2. Applies for external output and bidirectional buffers. V<sub>O</sub> > V<sub>CC</sub> does not apply to fail-safe terminals. PCI terminals and miscellaneous terminals are measured with respect to V<sub>CCP</sub> instead of V<sub>CC</sub>. PC Card terminals are measured with respect to V<sub>CCCB</sub>. The limit specified applies for a dc condition.

## 11.2 Recommended Operating Conditions

		OPERATION	MIN	NOM	MAX	UNIT
VR_PORT (see Table 2–6 for description)		1.8 V	1.6	1.8	2	V
ANALOGV <sub>CC</sub>		3.3 V	3	3.3	3.6	V
V <sub>CC</sub>		3.3 V	3	3.3	3.6	V
PLL <sub>V</sub> <sub>CC</sub>		3.3 V	3	3.3	3.6	V
PCI I/O clamping voltage, V <sub>C</sub> <sub>CP</sub>		V <sub>C</sub> <sub>CP</sub> = 3.3 V	3	3.3	3.6	V
		V <sub>C</sub> <sub>CP</sub> = 5 V	4.75	5	5.25	
V <sub>CC</sub> <sub>CB</sub> PC Card I/O clamping voltage		V <sub>CC</sub> <sub>CB</sub> = 3.3V	3	3.3	3.6	V
		V <sub>CC</sub> <sub>CB</sub> = 5 V	4.75	5	5.25	
High-level input voltage, V <sub>I</sub> <sub>H</sub> <sup>†</sup>	PC Card	3.3 V CardBus	0.475V <sub>CC</sub> <sub>CB</sub>		V <sub>CC</sub> <sub>CB</sub>	V
		3.3 V 16-bit	2.0		V <sub>CC</sub> <sub>CB</sub>	V
		5 V 16-bit	2.4		V <sub>CC</sub> <sub>CB</sub>	V
	PCI	3.3 V	0.5V <sub>C</sub> <sub>CP</sub>		V <sub>C</sub> <sub>CP</sub>	V
		5 V	2		V <sub>C</sub> <sub>CP</sub>	
	PC(0–2)		0.7V <sub>CC</sub>		V <sub>CC</sub>	
Miscellaneous <sup>‡</sup>		2		V <sub>CC</sub>		
Low-level input voltage, V <sub>I</sub> <sub>L</sub> <sup>†</sup>	PC Card	3.3 V CardBus	0		0.325V <sub>CC</sub> <sub>CB</sub>	V
		3.3 V 16-bit	0		0.8	V
		5 V 16-bit	0		0.8	V
	PCI	3.3 V	0		0.3V <sub>C</sub> <sub>CP</sub>	V
		5 V	0		0.8	
	PC(0–2)		0		0.2V <sub>CC</sub>	
Miscellaneous <sup>‡</sup>		0		0.8		
Input voltage, V <sub>I</sub>	PC Card		0		V <sub>CC</sub> <sub>CB</sub>	V
	PCI		0		V <sub>C</sub> <sub>CP</sub>	V
	Miscellaneous <sup>‡</sup>		0		V <sub>CC</sub>	V
Output voltage, V <sub>O</sub> <sup>§</sup>	PC Card		0		V <sub>CC</sub>	V
	PCI		0		V <sub>CC</sub>	V
	Miscellaneous <sup>‡</sup>		0		V <sub>CC</sub>	V
Input transition time (t <sub>r</sub> and t <sub>f</sub> ), t <sub>t</sub>	PCI and PC Card		1		4	ns
	Miscellaneous <sup>‡</sup>		0		6	ns
Output current, I <sub>O</sub>	TPBIAS outputs		–5.6		1.3	mA
Differential input voltage, V <sub>I</sub> <sub>D</sub>	Cable inputs, during data reception		118		260	mV
	Cable inputs, during arbitration		168		265	
Common-mode input voltage, V <sub>I</sub> <sub>C</sub>	TPB cable inputs, source power node		0.4706		2.515	V
	TPB cable inputs, nonsource power node		0.4706		2.015 <sup>¶</sup>	
Power up reset time, t <sub>pu</sub>	GRST input		2			ms
Receive input jitter	TPA, TPB cable inputs, S100 operation				±1.08	ns
	TPA, TPB cable inputs, S200 operation				±0.5	
	TPA, TPB cable inputs, S400 operation				±0.315	
Operating ambient temperature range, T <sub>A</sub>			0	25	70	°C
Virtual junction temperature, T <sub>J</sub> <sup>#</sup>	GRST input		0	25	115	°C

NOTE: Unused terminals (input or I/O) must be held high or low to prevent them from floating.

<sup>†</sup> Applies to external inputs and bidirectional buffers without hysteresis.

<sup>‡</sup> Miscellaneous terminals are: SDA, SCL, SUSPEND, GRST, CDx, VSx, CNA, and PHY\_TEST\_MA.

<sup>§</sup> Applies to external output buffers.

<sup>¶</sup> For a node that does not source power; see Section 4.2.2.2 in IEEE Std 1394a-2000.

<sup>#</sup> This junction temperature reflects simulation, the customer is responsible for verifying junction temperature.

## Recommended Operating Conditions (Continued)

		OPERATION	MIN	NOM	MAX	UNIT
Receive input skew	Between TPA and TPB cable inputs, S100 operation				±0.8	ns
	Between TPA and TPB cable inputs, S200 operation				±0.55	
	Between TPA and TPB cable inputs, S400 operation				±0.5	

## 11.3 Electrical Characteristics Over Recommended Operating Conditions (unless otherwise noted)

PARAMETER		OPERATION	TEST CONDITIONS	MIN	MAX	UNIT
V <sub>OH</sub>	High-level output voltage	PCI	3.3 V	I <sub>OH</sub> = -0.5 mA	0.9V <sub>CC</sub>	V
			5 V	I <sub>OH</sub> = -2 mA	2.4	
	PC Card	3.3 V CardBus	I <sub>OH</sub> = -0.15 mA	0.9V <sub>CC</sub>	V	
		3.3 V 16-bit	I <sub>OH</sub> = -0.15 mA	2.4	V	
		5 V 16-bit	I <sub>OH</sub> = -0.15 mA	2.8	V	
Miscellaneous <sup>‡</sup>		I <sub>OH</sub> = -4 mA	V <sub>CC</sub> - 0.6	V		
V <sub>OL</sub>	Low-level output voltage	PCI	3.3 V	I <sub>OL</sub> = 1.5 mA	0.1V <sub>CC</sub>	V
			5 V	I <sub>OL</sub> = 6 mA	0.55	
	PC Card	3.3 V CardBus	I <sub>OL</sub> = 0.7 mA	0.1V <sub>CC</sub>	V	
		3.3 V 16-bit	I <sub>OL</sub> = 0.7 mA	0.4	V	
		5 V 16-bit	I <sub>OL</sub> = 0.7 mA	0.55	V	
Miscellaneous <sup>‡</sup>		I <sub>OL</sub> = 4 mA	0.5	V		
I <sub>OZ</sub>	3-state output high-impedance	Output terminals	3.6 V	V <sub>O</sub> = V <sub>CC</sub> or GND	±20	μA
I <sub>OZL</sub>	High-impedance, low-level output current	Output terminals	3.6 V	V <sub>I</sub> = V <sub>CC</sub>	-1	μA
			5.25 V	V <sub>I</sub> = V <sub>CC</sub>	-1	
I <sub>OZH</sub>	High-impedance, high-level output current	Output terminals	3.6 V	V <sub>I</sub> = V <sub>CC</sub> <sup>†</sup>	10	μA
			5.25 V	V <sub>I</sub> = V <sub>CC</sub> <sup>†</sup>	25	
I <sub>IL</sub>	Low-level input current	Input terminals	3.6 V	V <sub>I</sub> = GND	±20	μA
		I/O terminals <sup>†</sup>	3.6 V	V <sub>I</sub> = GND	±20	
I <sub>IH</sub>	High-level input current	PCI <sup>†</sup>	3.6 V	V <sub>I</sub> = V <sub>CC</sub>	±20	μA
		Others <sup>†</sup>	3.6 V	V <sub>I</sub> = V <sub>CC</sub>	±20	
		Input terminals	3.6 V	V <sub>I</sub> = V <sub>CC</sub> <sup>‡</sup>	10	μA
			5.25 V	V <sub>I</sub> = V <sub>CC</sub> <sup>‡</sup>	20	
		I/O terminals	3.6 V	V <sub>I</sub> = V <sub>CC</sub> <sup>‡</sup>	10	
5.25 V	V <sub>I</sub> = V <sub>CC</sub> <sup>‡</sup>		25			

<sup>†</sup> For I/O terminals, input leakage (I<sub>IL</sub> and I<sub>IH</sub>) includes I<sub>OZ</sub> of the disabled output.

<sup>‡</sup> Miscellaneous terminals are: SDA, SCL, SUSPEND, GRST, CDx, VSx, CNA, and PHY\_TEST\_MA.

## 11.4 Electrical Characteristics Over Recommended Ranges of Operating Conditions (unless otherwise noted)

### 11.4.1 Device

PARAMETER	TEST CONDITIONS	MIN	TYP	MAX	UNIT	
V <sub>TH</sub>	Power status threshold, CPS input†			4.7	7.5	V
V <sub>O</sub>	TPBIAS output voltage			1.665	2.015	V
I <sub>I</sub>	Input current (PC0–PC2 inputs)				5	μA

† Measured at cable power side of resistor.

### 11.4.2 Driver

PARAMETER	TEST CONDITIONS	MIN	MAX	UNIT		
V <sub>OD</sub>	Differential output voltage			172	265	mV
I <sub>DIFF</sub>	Driver difference current, TPA+, TPA–, TPB+, TPB–			–1.05‡	1.05‡	mA
I <sub>SP200</sub>	Common-mode speed signaling current, TPB+, TPB–			–4.84§	–2.53§	mA
I <sub>SP400</sub>	Common-mode speed signaling current, TPB+, TPB–			–12.4§	–8.1§	mA
V <sub>OFF</sub>	Off state differential voltage				20	mV

‡ Limits defined as algebraic sum of TPA+ and TPA– driver currents. Limits also apply to TPB+ and TPB– algebraic sum of driver currents.

§ Limits defined as absolute limit of each of TPB+ and TPB– driver currents.

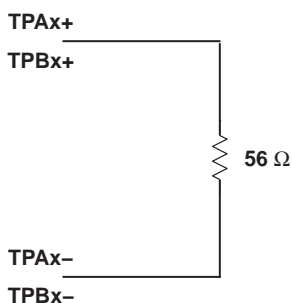

Figure 11–1. Test Load Diagram

### 11.4.3 Receiver

PARAMETER	TEST CONDITIONS	MIN	TYP	MAX	UNIT	
Z <sub>ID</sub>	Differential impedance	Drivers disabled	4	7	kΩ	
					4	pF
Z <sub>IC</sub>	Common-mode impedance	Drivers disabled	20		kΩ	
					24	pF
V <sub>TH-R</sub>	Receiver input threshold voltage			–30	30	mV
V <sub>TH-CB</sub>	Cable bias detect threshold, TPBx cable inputs			0.6	1	V
V <sub>TH+</sub>	Positive arbitration comparator threshold voltage			89	168	mV
V <sub>TH–</sub>	Negative arbitration comparator threshold voltage			–168	–89	mV
V <sub>TH-SP200</sub>	Speed signal threshold			49	131	mV
V <sub>TH-SP400</sub>	Speed signal threshold			314	396	mV

## 11.5 PCI Clock/Reset Timing Requirements Over Recommended Ranges of Supply Voltage and Operating Free-Air Temperature

PARAMETER		ALTERNATE SYMBOL	TEST CONDITIONS	MIN	MAX	UNIT
$t_c$	Cycle time, PCLK	$t_{cyc}$		30		ns
$t_{w(H)}$	Pulse duration (width), PCLK high	$t_{high}$		11		ns
$t_{w(L)}$	Pulse duration (width), PCLK low	$t_{low}$		11		ns
$t_r, t_f$	Slew rate, PCLK	$\Delta v/\Delta t$		1	4	V/ns
$t_w$	Pulse duration (width), $\overline{GRST}$	$t_{rst}$		1		ms
$t_{su}$	Setup time, PCLK active at end of PRST	$t_{rst-clk}$		100		$\mu s$

## 11.6 Switching Characteristics for PHY Port Interface

PARAMETER		TEST CONDITIONS	MIN	TYP	MAX	UNIT
Jitter, transmit		Between TPA and TPB			$\pm 0.15$	ns
Skew, transmit		Between TPA and TPB			$\pm 0.1$	ns
$t_r$	TP differential rise time, transmit	10% to 90%, at 1394 connector	0.5		1.2	ns
$t_f$	TP differential fall time, transmit	90% to 10%, at 1394 connector	0.5		1.2	ns

## 11.7 Operating, Timing, and Switching Characteristics of XI

PARAMETER		MIN	TYP	MAX	UNIT
$V_{CC}$		3	3.3	3.6	V (PLL $V_{CC}$ )
$V_{IH}$	High-level input voltage	0.63 $V_{CC}$			V
$V_{IL}$	Low-level input voltage	0.33 $V_{CC}$			V
Input clock frequency		24.576			MHz
Input clock frequency tolerance		<100			PPM
Input slew rate		0.2		4	V/ns
Input clock duty cycle		40%		60%	

## 11.8 PCI Timing Requirements Over Recommended Ranges of Supply Voltage and Operating Free-Air Temperature

This data manual uses the following conventions to describe time (  $t$  ) intervals. The format is  $t_A$ , where *subscript A* indicates the type of dynamic parameter being represented. One of the following is used:  $t_{pd}$  = propagation delay time,  $t_d$  ( $t_{en}$ ,  $t_{dis}$ ) = delay time,  $t_{su}$  = setup time, and  $t_h$  = hold time.

PARAMETER		ALTERNATE SYMBOL	TEST CONDITIONS	MIN	MAX	UNIT
$t_{pd}$	PCLK-to-shared signal valid delay time	$t_{val}$	$C_L = 50$ pF, See Note 3		11	ns
	PCLK-to-shared signal invalid delay time	$t_{inv}$		2		
$t_{en}$	Enable time, high impedance-to-active delay time from PCLK	$t_{on}$		2		ns
$t_{dis}$	Disable time, active-to-high impedance delay time from PCLK	$t_{off}$			28	ns
$t_{su}$	Setup time before PCLK valid	$t_{su}$		7		ns
$t_h$	Hold time after PCLK high	$t_h$		0		ns

NOTE 3: PCI shared signals are AD31–AD0, C/BE3–C/BE0, FRAME, TRDY, IRDY, STOP, IDSEL, DEVSEL, and PAR.

### 11.8.1 CardBus PC Card Clock Specifications

PARAMETER		MIN	MAX	UNIT
$t_{cyc}$	CCLK cycle time (see Note 4)	30	$\infty$	ns
$t_{high}$	CCLK high time	12		ns
$t_{low}$	CCLK low time	12		ns
–	CCLK slew rate (see Note 5)	1	4	V/ns

- NOTES:
- In general, all CardBus PC Card components must work with any clock frequency up to 33 MHz. The clock frequency may be changed at any time during the operation of the system so long as the clock edges remain clean (monotonic) and the minimum cycle and high and low times are not violated. If the clock is stopped, it must be in a low state. A variance on this specification is allowed for the CardBus PC Card adapter which may operate the CardBus PC Card interface at any single fixed frequency up to 33 MHz, and may enforce a policy of no frequency changes.
  - Rise and fall times are specified in terms of the edge rate measured in V/ns. This slew rate must be met across the minimum peak-to-peak portion of the clock waveform (see Figure 11–2).

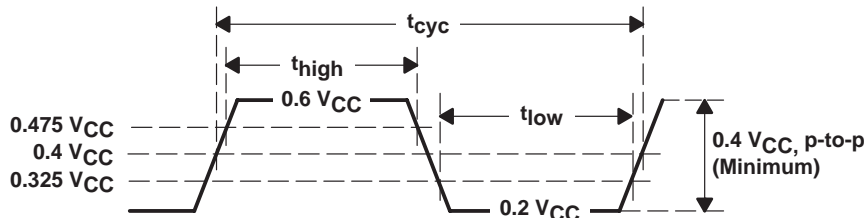

Figure 11–2. CardBus PC Card Clock Waveform

### 11.8.2 3.3-V Timing Parameters

		MIN	MAX	UNIT
$t_{val}$	CCLK-to-signal-valid delay (see Notes 6 and 7)	2	18	ns
$t_{on}$	Float-to-active delay (see Note 6)	2		ns
$t_{off}$	Active-to-float delay (see Note 6)		28	ns
$t_{su}$	Input set up time to CCLK (see Note 8)	7		ns
$t_h$	Input hold time from CCLK (see Note 8)	0		ns
$t_{rst}$	Reset active time after power stable (see Note 9)	1		ms
$t_{rst-clk}$	Reset active time after CCLK stable (see Note 9)	100		clocks
$t_{rst-off}$	Reset-active-to-output-float delay (see Notes 9 and 10)		40	ns
$t_{pulse}$	CSTSCHG remote wakeup pulse width (see Note 11)	1		ms

- NOTES:
- $t_{val}$  includes the time to propagate data from internal registers to the output buffer and drive the output to a valid level. Minimum  $t_{val}$  is measured from CCLK crossing  $V_{test}$  to the signal crossing  $V_{IH}$  on falling edges and  $V_{IL}$  on rising edges. Maximum  $t_{val}$  is measured from CCLK crossing  $V_{test}$  to the signal's last transition out of the threshold region ( $V_{IL}$  for falling edges,  $V_{IH}$  for rising edges).
  - Minimum times are specified with 0-pF equivalent load; maximum times are specified with 30-pF equivalent load. Actual test capacitance may vary, but results must be correlated to these specifications. Systems which exceed this capacitance, due to long traces between the socket and adaptor, must reduce the CCLK frequency appropriately.
  - $t_{su}$  and  $t_h$  are measured at  $V_{TH}$  for rising edges and  $V_{TL}$  for falling edges.
  - CRST is asserted asynchronously and negated synchronously with respect to CCLK. CCLK Stable means that  $V_{CC}$  is within tolerances and CCLK is meeting specifications.
  - See *PC Card Standard—Electrical Specification* for the CardBus PC Card and adapter signals which must be in a high-impedance state.
  - This parameter only applies when signaling remote wakeup over the CSTSCHG terminal. All other status change information must be signaled by asserting CSTSCHG until the resultant interrupt is serviced.

## 12 Mechanical Information

The PCI4510 is packaged either in a GHK or ZHK 209-ball BGA, a 208-pin PDV package, or an RGVF or RZVF 224-ball MicroStar BGA™. The following shows the mechanical dimensions for the GHK, PDV, RGVF, RZVF, and ZHK packages.

**GHK (S-PBGA-N209)**

**PLASTIC BALL GRID ARRAY**

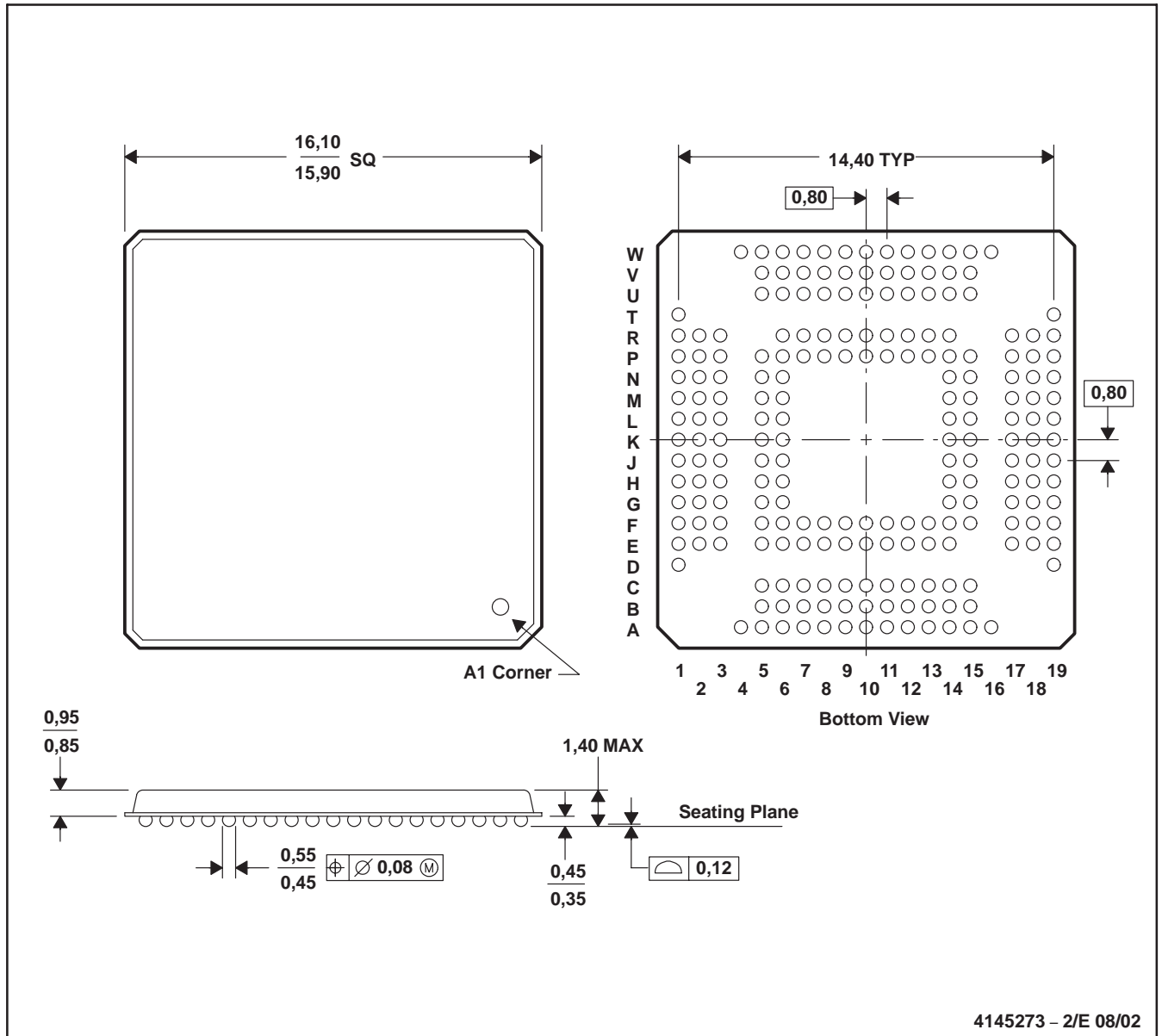

- NOTES: A. All linear dimensions are in millimeters.  
 B. This drawing is subject to change without notice  
 C. MicroStar BGA™ configuration

MicroStar BGA is a trademark of Texas Instruments.

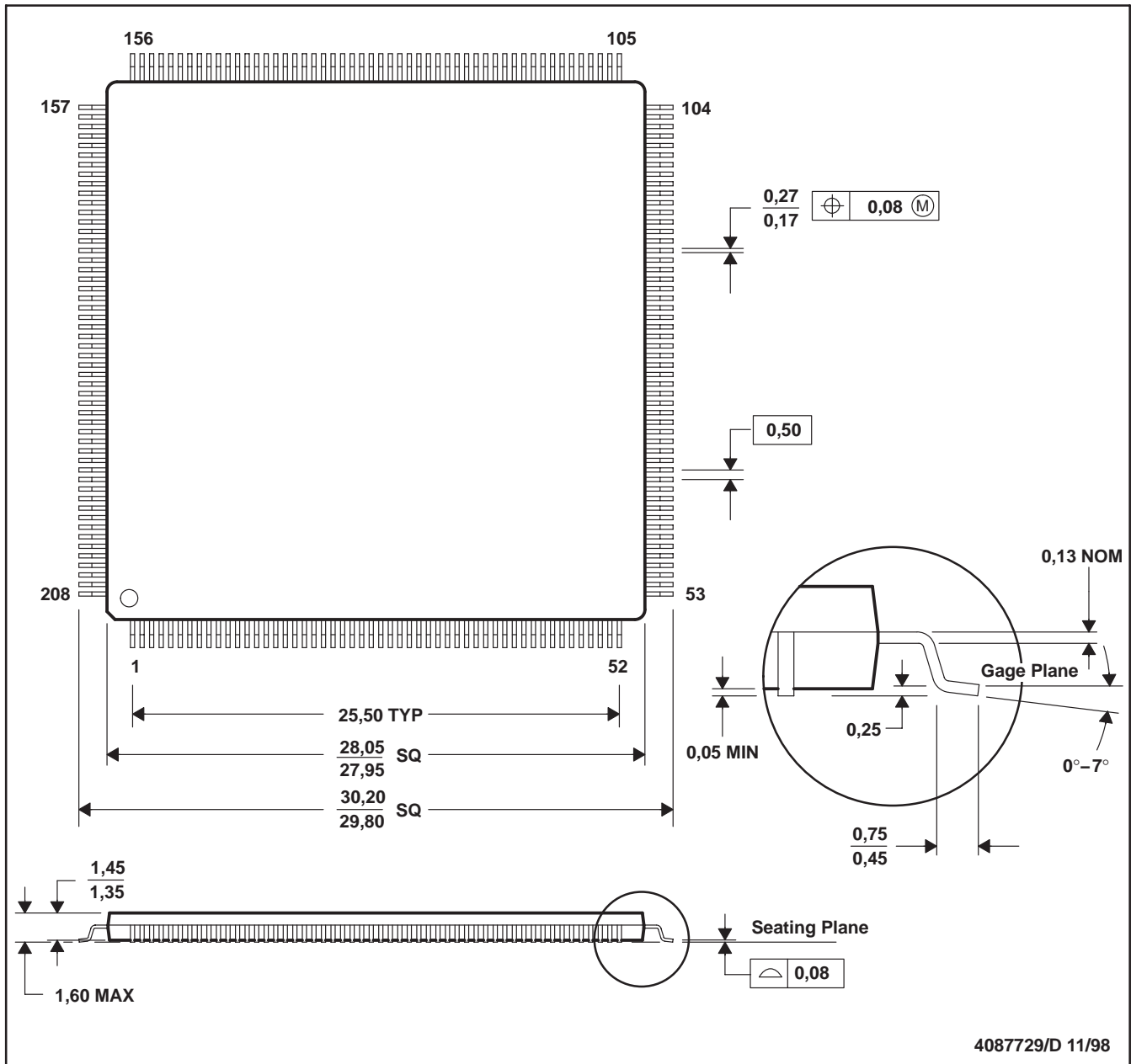

- NOTES: A. All linear dimensions are in millimeters.  
 B. This drawing is subject to change without notice.  
 C. Falls within JEDEC MS-026



RGVF (S-PBGA-N224)

PLASTIC BALL GRID ARRAY

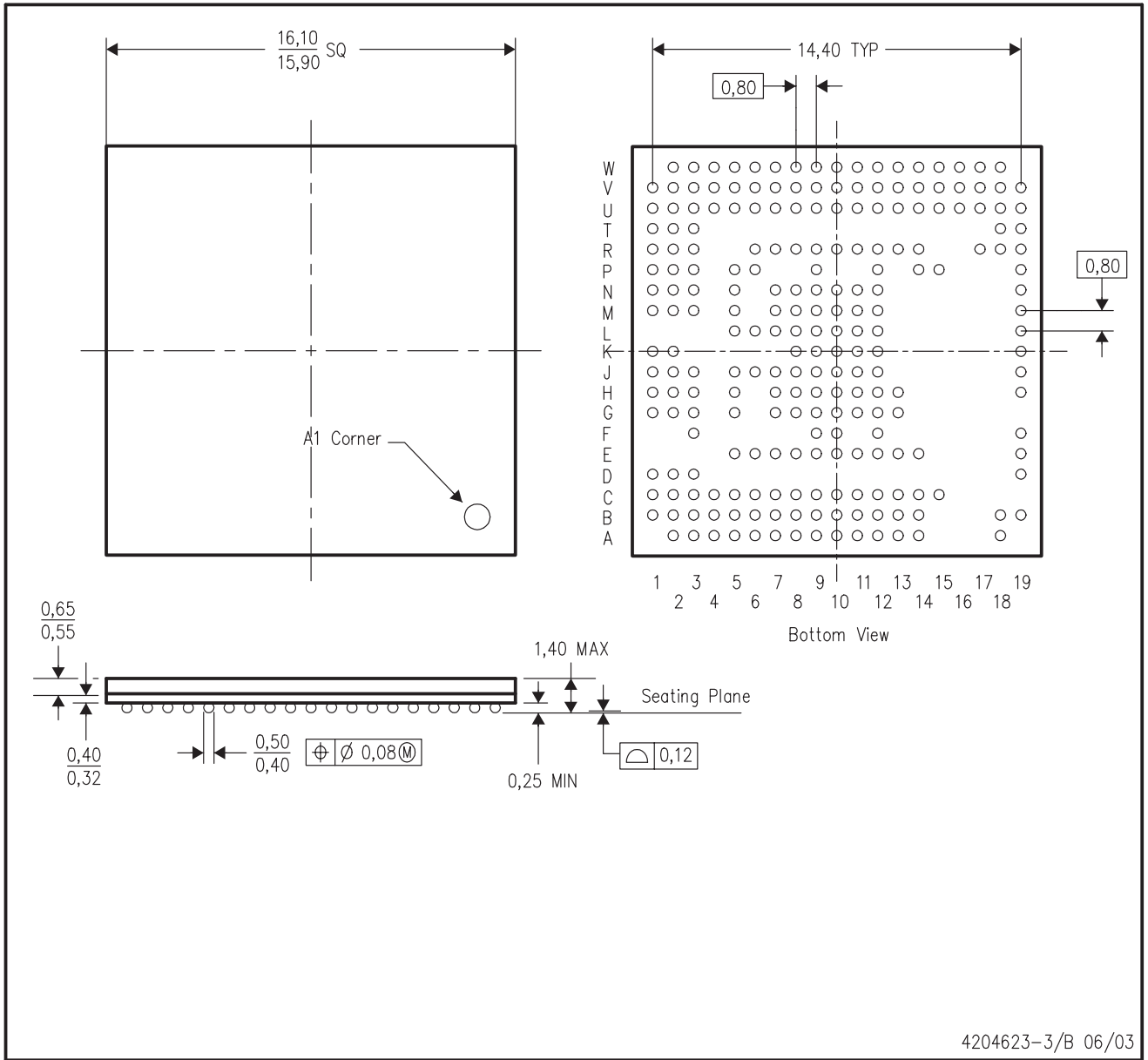

4204623-3/B 06/03

- NOTES: A. All linear dimensions are in millimeters.  
 B. This drawing is subject to change without notice.

RZVF (S-PBGA-N224)

PLASTIC BALL GRID ARRAY

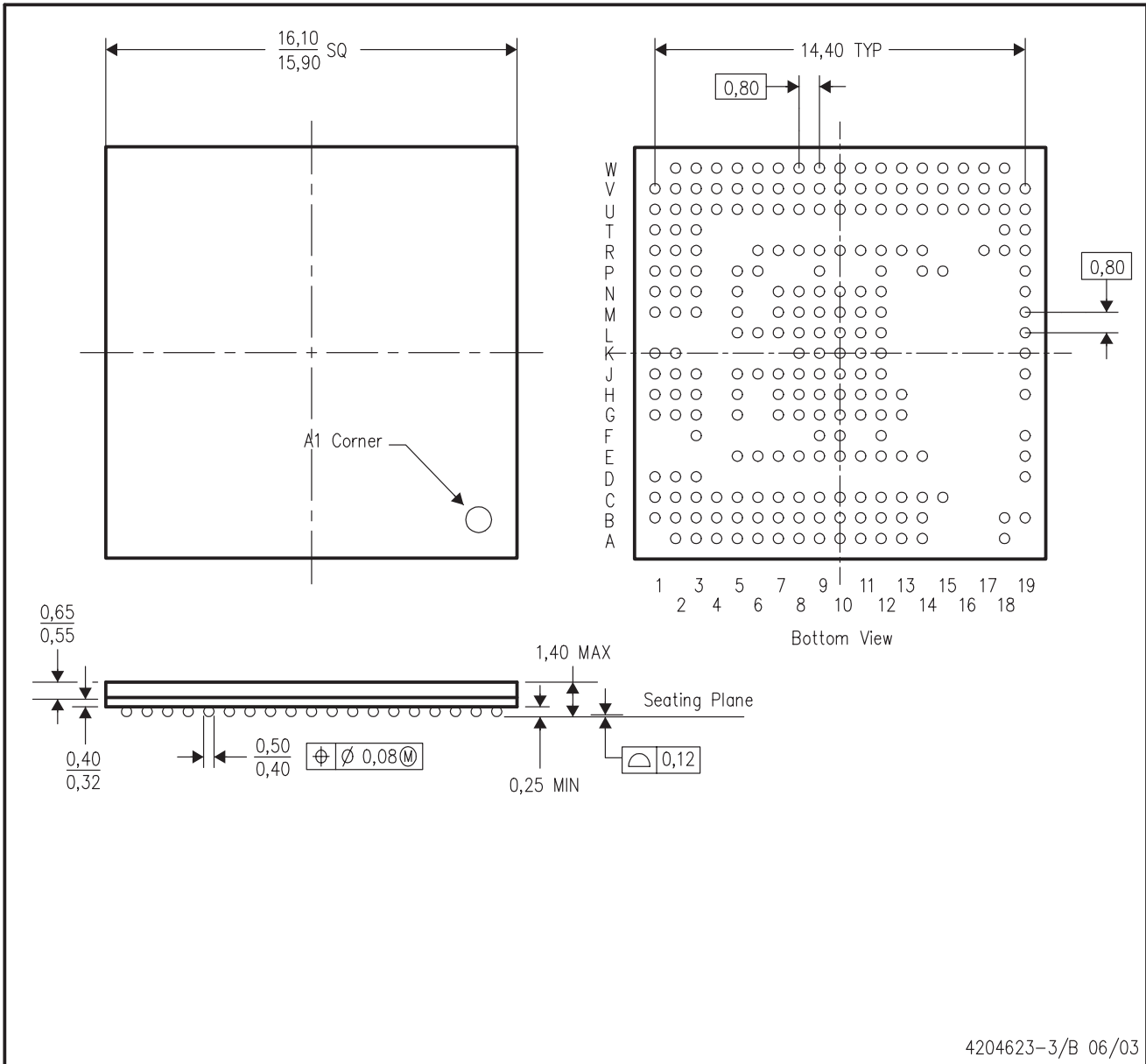

4204623-3/B 06/03

- NOTES: A. All linear dimensions are in millimeters.  
 B. This drawing is subject to change without notice.

ZHK (S-PBGA-N209)

PLASTIC BALL GRID ARRAY

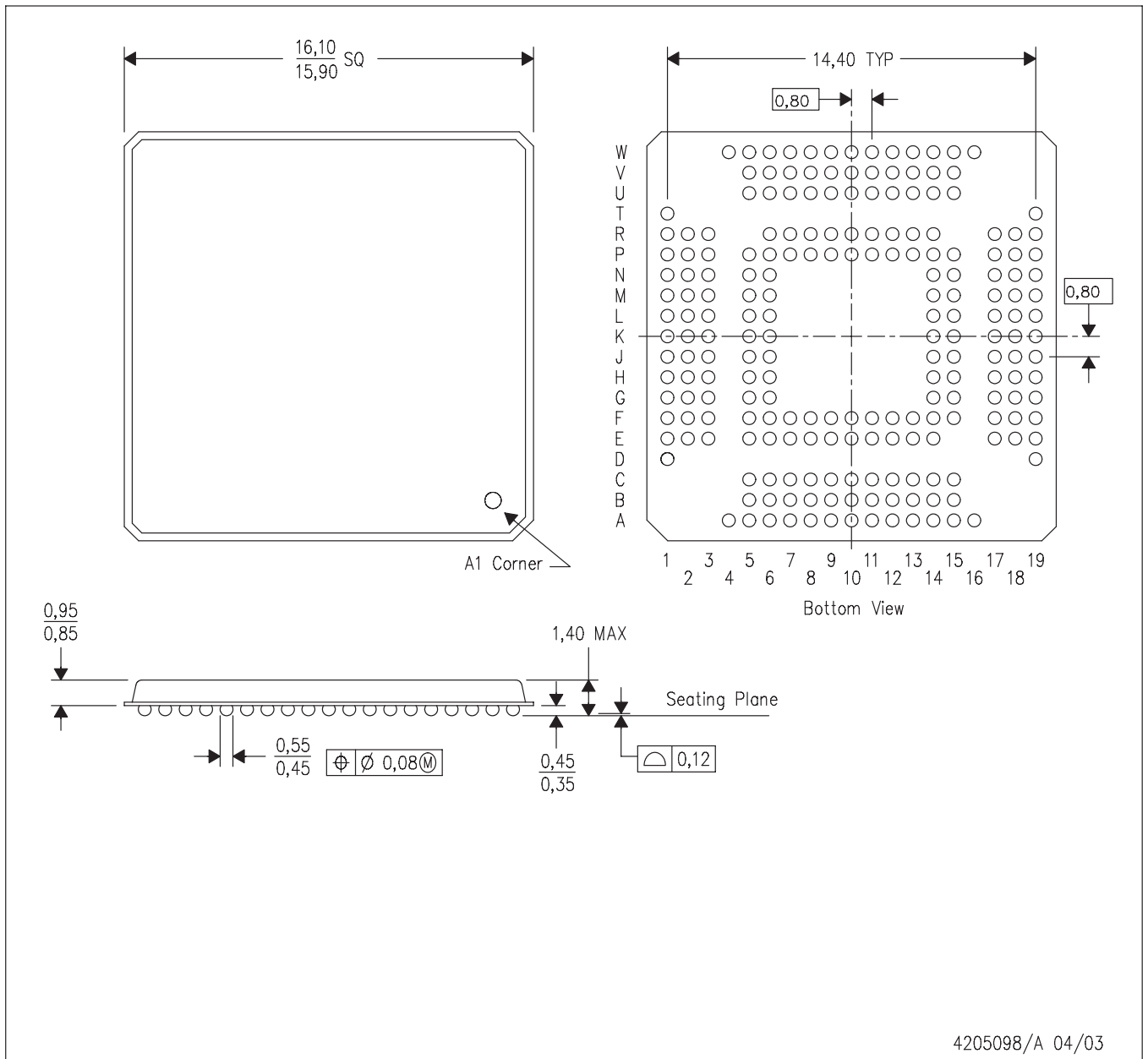

- NOTES:
- A. All linear dimensions are in millimeters.
  - B. This drawing is subject to change without notice.
  - C. Micro Star BGA configuration
  - D. This package is lead-free.

