

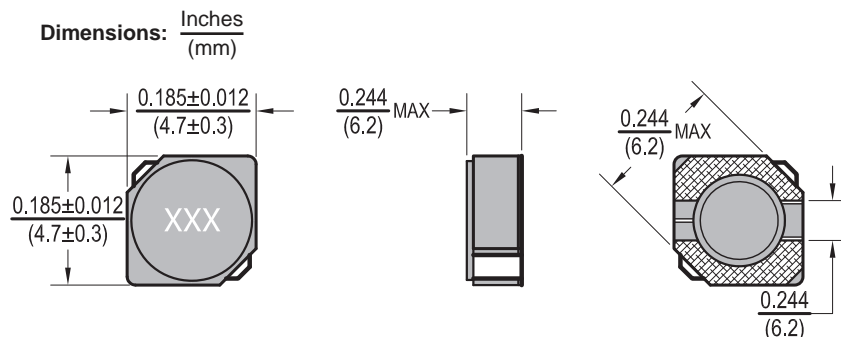

Power Chip Shielded Inductors PCS4D18

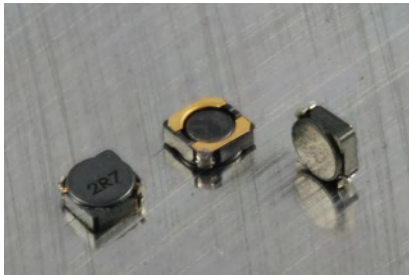

Allied Part Number	Inductance (μH)	Tolerance (%)	Test Freq.	DCR (Ω)	Rated Current (A) Max.
PCS4D18-1R0N-RC	1.0	30	7.96 MHz	0.045	1.72
PCS4D18-1R5N-RC	1.5	30	7.96 MHz	0.060	1.50
PCS4D18-1R8N-RC	1.8	30	7.96 MHz	0.070	1.35
PCS4D18-2R2N-RC	2.2	30	7.96 MHz	0.075	1.32
PCS4D18-2R7N-RC	2.7	30	7.96 MHz	0.105	1.28
PCS4D18-3R3N-RC	3.3	30	7.96 MHz	0.110	1.04
PCS4D18-3R9N-RC	3.9	30	7.96 MHz	0.155	0.88
PCS4D18-4R7N-RC	4.7	30	7.96 MHz	0.162	0.84
PCS4D18-5R6N-RC	5.6	30	7.96 MHz	0.170	0.80
PCS4D18-6R8N-RC	6.8	30	7.96 MHz	0.200	0.76
PCS4D18-8R2N-RC	8.2	30	7.96 MHz	0.245	0.68
PCS4D18-100N-RC	10	30	100 KHz	0.280	0.61
PCS4D18-120N-RC	12	30	100 KHz	0.320	0.56
PCS4D18-150N-RC	15	30	100 KHz	0.360	0.50
PCS4D18-180N-RC	18	30	100 KHz	0.400	0.48
PCS4D18-220N-RC	22	30	100 KHz	0.480	0.41
PCS4D18-270N-RC	27	30	100 KHz	0.570	0.35
PCS4D18-330N-RC	33	30	100 KHz	0.694	0.32
PCS4D18-390N-RC	39	30	100 KHz	0.800	0.30
PCS4D18-470N-RC	47	30	100 KHz	0.950	0.28
PCS4D18-560N-RC	56	30	100 KHz	1.080	0.26
PCS4D18-680N-RC	68	30	100 KHz	1.300	0.24
PCS4D18-101N-RC	100	30	100 KHz	2.000	0.20

Features

- Shielded SMD Power Inductor
- Available in magnetically shielded
- Ideal for DC-DC converter applications

Electrical

Inductance Range: 1μH to 100μH

Tolerance: 30% over entire range,

Operating Temp: -30°C ~ +100°C

IDC: Current at which inductance drops by 35% of initial value or ΔT=40°C lower, whichever is lower.

Resistance to Soldering Heat

Pre-Heat 150°C, 1 min.

Solder Temp: 260°C ± 5°C for 10sec ± 1sec.

Solder Composition: Sn/Ag3.0/Cu0.5

Test Equipment

(L): HP 4192A LF Impedance Analyzer

(RDC): Chen Hwa 502

Rate Current: HP4284+HP42841A or

Chen Hwa 1061 + Chen Hwa 301A

Physical

Packaging: 2000 pieces per 13 inch reel

Marking: EIA Inductance Code