



OnChip Systems

PCT 14

PRODUCT HIGHLIGHTS

- Complete audio processing and tone signalling on a single chip.
- Few external components
- Low pin count and small size: 20 pin plastic DIP or SOIC package.
- No trimming required.
- Three different pilot tone frequencies available
- Pilot delay timer accommodates hook signalling.
- Page tone generation.
- Ring tone detection
- Hook and pulse dialing control
- Low battery indication.
- Low current drain: > 1mA
- Low cost.

Cordless Telephone Handset Subsystem

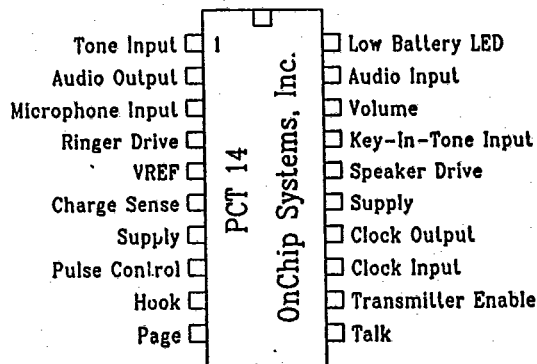

Ordering Information:

- PCT 14P 20 pin plastic DIP
- PCT 14S 20 pin plastic Small Outline (SOIC)

Description

The PCT 14 Cordless Telephone Handset Subsystem IC performs all the audio processing and tone signalling functions required of the handset in a cordless telephone system. Included onchip are the earpiece driver with selectable gain, a microphone preamplifier and DTMF tone mixer, a ring tone detector circuit for driving an external transducer with the ring tone, and a lowbattery voltage indicator. Additionally, a pilot tone oscillator generates one of three possible pilot

tones for signalling the base unit to connect to the telephone line, a page tone oscillator allows the handset user to signal the base for intercom operation, and a charge sense circuit detects when the handset is in or out of the base cradle. Finally, on-chip logic allows enabling of the external transmission circuitry, hook control and pulse dialing modulation of the pilot tone, and selection of a standby mode for low power consumption. Use of switched capacitor techniques and crystal controlled divider chains for the detection

filters and tone generators not only eliminate many external components but provide extremely high frequency accuracy without the need for any external circuit trimming. Able to operate down to 3.3V (three 1.2V battery cells) and requiring low power (less than 1mA in standby mode) the PCT 14 allows low cost cordless telephone handsets to be implemented with just the addition of a standard IF/FM demodulator IC, standard DTMF generator and simple RF receiver and transmitter circuitry.

ON CHIP SYSTEMS

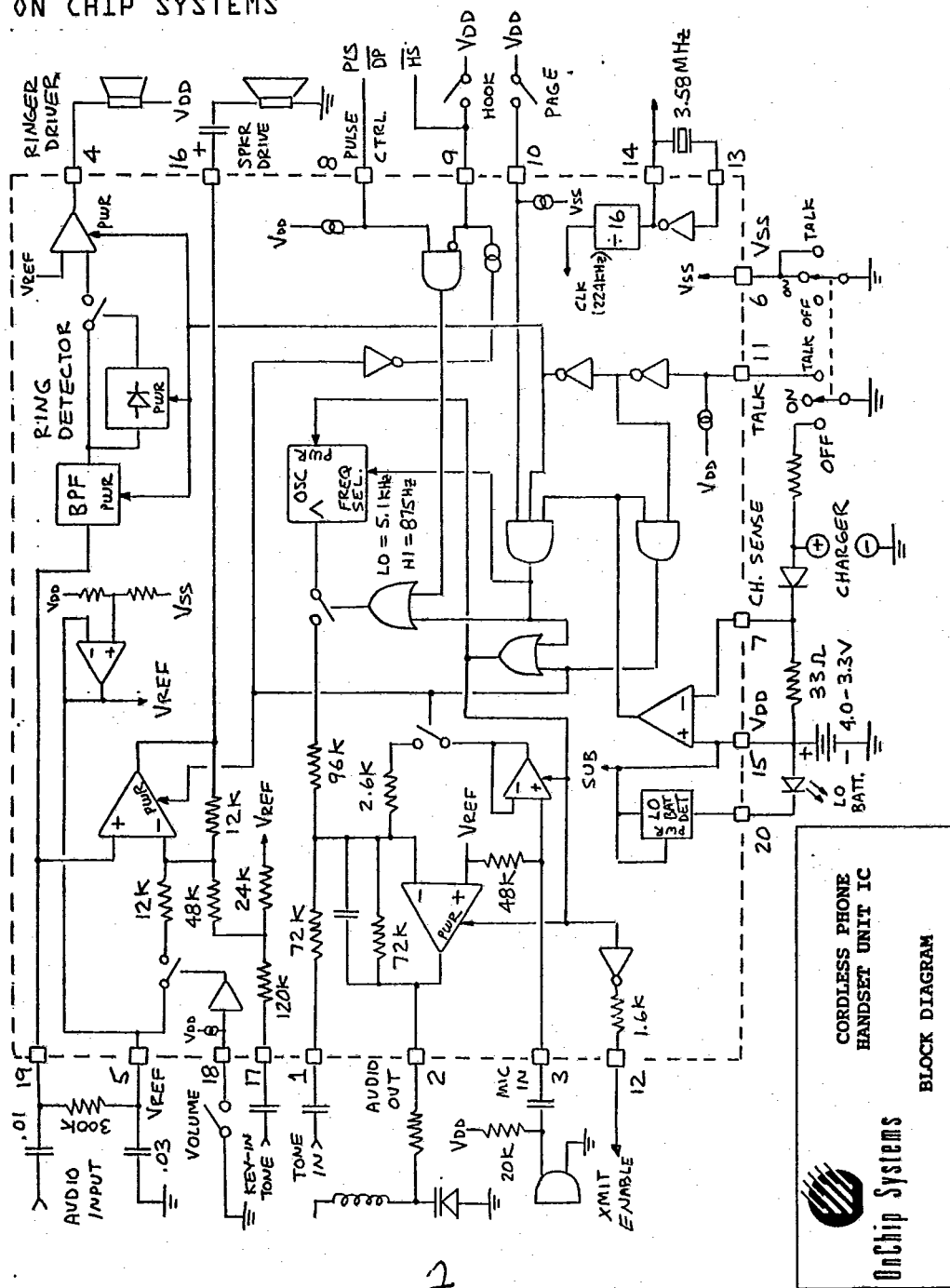

ON CHIP SYSTEMS

CORDLESS PHONE HANDSET UNIT
SIMPLIFIED SCHEMATIC
REVISED 9/16/88

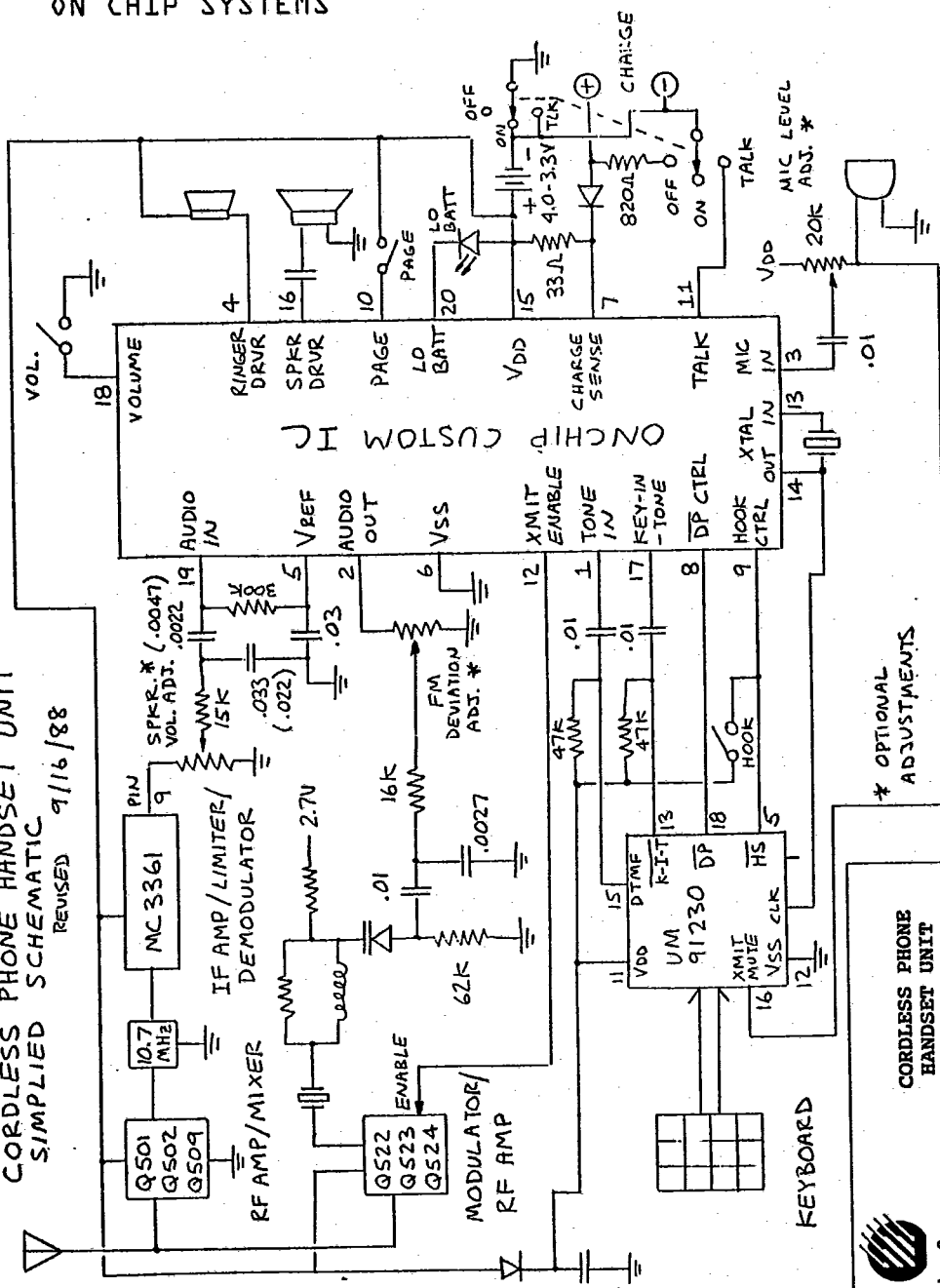

OPTIONAL ADJUSTMENTS

CORDLESS PHONE
HANDSET UNIT

ONChip Systems

STANDARDIZED SCHEMATIC

W

Functional Description - Handset IC (20 pin)

Audio Input Pin: (pin 19)

Accepts band limited audio output from FM demodulator (50mV.P.P. nominal) and applies it to the speaker amplifier and ring tone detector. The input must be biased through a resistor from the Vref pin, which sets the input impedance. The speaker amplifier provides a gain of 2.2 nominal with Vol pin "high" or "open", supplying 100mV.R.M.S into 8 ohms at the Speaker Drive pin for driving the external speaker.

The ring tone detector consists of a 2nd order bandpass filter with center frequency at 2.0KHz and bandwidth of +/- 100 Hz, followed by a rectifier and threshold comparator. When the Talk pin is "open" or "high", the detector is activated and, if the ring tone is present, the detector connects the output of the filter to a high gain squaring circuit which can provide 10mA of pull down drive to the Ringer Drive pin for energizing the ringer. The detector is disabled whenever the Talk pin is "low".

Volume pin: (pin 18)

When brought low, the gain of the speaker amplifier is reduced from 2.2 to 1.2 (6dB).

Speaker Drive pin: (pin 16)

Provides more than 15mA peak drive to the external speaker (2mW peak power into 8 ohm). The speaker amplifier is activated only when the Talk pin is "low" and the handset is not in-cradle. A trim pot may be used in series with the speaker to adjust the speaker volume if necessary.

Ringer Drive pin: (pin 4)

Provides more than 10mA of pull down drive at the ring tone frequency for energizing the ringer.

Key-In-Tone Input pin: (pin 17)

Accepts "Key-In-Tone output" from tone dialer chip and applies it to speaker amplifier. Gain is .04 nominal, and is not affected by the Vol. pin.

Hook pin: (pin 9)

This pin is both an input and an output with low drive (15uA) which normally connects to the Hook Switch input on the Touch Tone dialer IC. This pin provides a "low" output for enabling the keyboard and dialer IC whenever the Talk pin is brought "low" and the handset is not in-cradle. In such state, a "high" (i.e.VDD) applied to this pin through the hook switch will override the weak pulldown, both disabling the dialer IC and the pilot tone if being generated. A pilot tone is generated at either 4.0, 5.1, or 5.9KHZ (selectable by metal mask option) and will appear at the Audio Output pin whenever the Talk pin is "low", the handset is not in-cradle, the Pulse Control pin is being held "high" or left "open", and the Hook pin is left "open" so that it is being pulled "low".

Pulse Control pin: (pin 8)

With an internal pull-up to VDD, an "open" condition or "high" applied to this pin will activate the pilot tone if also the Hook pin is "low", the Talk pin is "low", and the handset is not in-cradle. Normally connected to the "Dial Pulse Output" of the tone dialer chip, this pin is used for "make and break" control of the phone

line in the pulse dial mode, where a momentary "low" applied to this pin will disable (inhibit) the pilot tone if being generated, which will cause the Base IC to momentarily disconnect the phone line.

Page pin: (pin 10)

Whenever this pin is brought "high" and the Talk pin is "high" and the handset is not in-cradle, then the tone oscillator is activated to generate the page frequency of 875HZ and the resulting page tone appears at the Audio Output pin. In addition, the Transmitter Enable pin is forced to its active low state.

Tone Input pin: (pin 1)

Accepts the DTMF dual tone output of the tone dialer chip, and passes it through the Tone mixer and low pass filter to the Audio Output pin at a gain of 1.0. Input impedance is 72K internally biased at VREF.

Microphone Input pin: (pin 3)

Accepts the microphone output signal and, whenever the Talk pin is "low" and the handset not in-cradle, connects it to the microphone amplifier where it is amplified with a gain of 30 nominal before appearing at the Audio Output pin. The amplifier is also activated whenever the page tone is activated, but the microphone is not connected. Input impedance is 48K nominal, and since this input is internally biased at VREF, an input coupling capacitor will normally be required. A series trim pot may also be necessary to adjust the microphone output to the desired levels.

Audio Output pin: (pin 2)

This is the output of the microphone amplifier/tone mixer, and provides either the page tone or pilot tone, as well as the amplified microphone output and DTMF generator output to the FM modulator. An internal low pass Filter with 4.8KHz cutoff frequency and 6dB/octave roll off is provided to band limit the output signals. The output impedance is less than 500 ohm, and the quiescent DC output level of VREF may be used to directly bias the varactor diode. If additional band limiting is required, the output may be passed through an external RC low pass filter. Finally, a trim pot may be necessary to adjust the final level applied to the varactor diode, so that the resulting FM deviation complies to FCC specifications.

Transmitter Enable pin: (pin 12)

Provides a 1.6K ohm pull down to VSS whenever the page tone is activated, or Talk pin is brought low and handset not in-cradle. This pin may be used to enable power-up of the external FM modulator and RF amplifier transmission circuitry (by driving the base of a PNP transistor, for example).

Talk pin: (pin 11)

Whenever this pin is brought low and the handset is not in-cradle, internal power is applied to the speaker amplifier, Microphone amplifier, and oscillator, and the microphone is connected to the microphone amplifier. Power is removed from the ring tone detector /driver circuit (i.e. it is disabled). In addition, the Transmitter Enable pin is activated "low". Note that power is also applied but only to the microphone amplifier/tone mixer and oscillator whenever the page tone is activated. When in this talk mode, power drain is increased, but is less than 3mA.

ON CHIP SYSTEMS

OnChip Systems, Inc.

PCT 14

Clock Input and Output pins: (pins 13 & 14)

A standard 3.58MHz clock crystal connected between these pins generates the necessary internal clock signals which determine the filter and tone oscillator frequencies. The signal from the XTAL Output pin may be capacitively coupled to the tone dialer chip to provide it with the necessary clock frequency when activated.

Low Battery LED pin: (pin 20)

This pin provides an active pull down of more than 5mA at 2.4V for turning on the Low Battery LED whenever VDD is applied to the chip and is less than 3.3V.

VREF pin: (pin 5)

An internally generated and buffered reference voltage, approximately $1/2(VDD-.6)$, is brought out to this pin and should be bypassed with a .005 to .05uF capacitor.

Charge Sense and Supply pins: (pins 6, 7, & 15)

The battery power is supplied to the chip between the VDD and VSS pins. The charging terminal supplies the Charge Sense pin through a diode and then through a current limiting resistor to the VDD pin. Whenever the Charge Sense pin is higher than VDD pin by more than 300mV, as is the case when the handset is in the cradle, then the sense comparator output prevents the page tone from being activated, and prevents a "low" on the Talk pin from enabling all functions explained above.

ON CHIP SYSTEMS

OnChip Systems, Inc.

PCT 14

Specifications - Handset

VDD = 4.0V

	Min.	Typical	Max.	Unit
Audio Input				
Impedance	108	---	---	ohm
Signal Level	---	---	400	mV.P.P.
Ring Tone Filter				
Center Frequency	---	2.0	---	KHz
Tolerance	-5	---	+5	%
Bandwidth	---	+100	---	Hz
Detection Threshold				
At 2150 Hz	---	60	--	mV.P.P.
At 1810 Hz	---	65	---	mV.P.P.
Detection Hysteresis	---	35	---	mV.P.P.
Response Time	---	60	---	mS
Speaker Driver				
Output Level	---	---	280	mV.P.P.
Output Power	---	---	23	mW Peak
Impedance	---	1.6	---	ohm
Gain from Audio Input				
VOL = HI	---	2.2	---	
VOL = LO	---	1.2	---	
Gain from Key-In-Tone	---	.04	---	

ON CHIP SYSTEMS

PCT 14

OnChip Systems, Inc.

	Min.	Typical	Max.	Unit
Key-In-Tone Input				
Impedance	---	136K	---	ohm
Signal Level	---	---	VDD	V.P.P.
DTMF Tone Input				
Impedance	---	72K	---	ohm
Signal Level	---	---	VDD	V.P.P.
Microphone Input				
Impedance	---	48K	---	
Signal Level	---	---	100	mV.P.P.
Audio Output				
Impedance	---	500	---	ohm
Signal Level	---	---	3.2	V.P.P.
Gain from DTMF Input	---	1.0	---	
Gain from Mic Input	---	30	---	
Bandwidth	3.6	4.8	6.0	KHz
Minimum Load	12K	---	---	ohm
Oscillator				
Frequency, Page Mode	---	875	---	Hz
Frequency, Pilot Mode	4.0	5.1	5.9	KHz
Frequency Tolerance	= XTAL			%
Waveform		Triangle		
Output Level, Page	---	2.1	---	V.P.P.
Output Level, Pilot	---	1.0	---	V.P.P.
Ringer Drive (Open Drain)				
Pull-down Resistance	---	150	---	ohm

ON CHIP SYSTEMS

OnChip Systems, Inc.

PCT 14

	Min.	Typical	Max.	Unit
Transmitter Enable				
Pull-down Resistance	---	1.6	---	Kohm
Low Battery LED				
Pull-down Drive @ 2.4V	---	5	---	mA
VDD for Activation	3.3	3.45	3.6	V
VOL Input				
Talk Enable Input				
Pulse Control Input				
Internal Pull-up	---	15	---	uA
Low Threshold	---	1.8	---	V
Page Enable Input				
Hook Control Input/Output				
Internal Pull-down	---	15	---	uA
High Threshold	---	1.8	---	V
Clock Input Impedance				
Clock Output Level	1.0	---	VDD	V.P.P.
Charge Sense Input				
Threshold re. VDD	---	+300	---	mV
Input Bias Current		15		uA

ON CHIP SYSTEMS

OnChip Systems, Inc.

PCT 14

	Min.	Typical	Max.	Unit
Supply				
Voltage Range	3.3	---	10	V
Current Drain				
Talk pin open	---	---	500	uA
Talk pin low	---	---	3	mA

ON CHIP SYSTEMS

Handset Truth Table

Ring Tone @ Audio In		INPUTS					OUTPUTS					OPERATION
	Talk Pin	Charge Current	Page Pin	Hook Pin	Pulse Control	Audio Out	Speaker Out	Ringer	Hook Pin	Transmit Enable		
-	H	X	X	X	X	-	-	-	H	*	Standby	
S	H	X	X	X	X	-	-	R	H	*	Ring	
X	H	-	H	X	X	P	-	*	H	L	Page Base	
X	L	-	X	X	X	M/*	A	-	L	L	Enable Mic & Speaker Amp	
X	L	-	X	L	H	M/Q	A	-	L	L	Line Connect (Generate Pilot)	

- Key:
- S Signal Present
 - Signal Not Present/Function Not Enabled
 - L Low Logic Level
 - H High Logic Level
 - X Don't Care
 - * Depends on Don't Care Inputs
 - A Signal Applied to Audio Input
 - M Signal Applied to Microphone Input
 - Q Pilot Tone
 - P Page Tone
 - R Ring Tone

5