

# 32 Mbit SPI Serial Flash

## PCT25VF032B



Data Sheet

### FEATURES:

- **Single Voltage Read and Write Operations**
  - 2.7-3.6V
- **Serial Interface Architecture**
  - SPI Compatible: Mode 0 and Mode 3
- **High Speed Clock Frequency**
  - 80 MHz Max
- **Superior Reliability**
  - Endurance: 100,000 Cycles (typical)
  - Greater than 100 years Data Retention
- **Low Power Consumption:**
  - Active Read Current: 10 mA (typical)
  - Standby Current: 5  $\mu$ A (typical)
- **Flexible Erase Capability**
  - Uniform 4 KByte sectors
  - Uniform 32 KByte overlay blocks
  - Uniform 64 KByte overlay blocks
- **Fast Erase and Byte-Program:**
  - Chip-Erase Time: 35 ms (typical)
  - Sector-/Block-Erase Time: 18 ms (typical)
  - Byte-Program Time: 7  $\mu$ s (typical)
- **Auto Address Increment (AAI) Word Programming**
  - Decrease total chip programming time over Byte-Program operations
- **End-of-Write Detection**
  - Software polling the BUSY bit in Status Register
  - Busy Status readout on SO pin
- **Hold Pin (HOLD#)**
  - Suspends a serial sequence to the memory without deselecting the device
- **Write Protection (WP#)**
  - Enables/Disables the Lock-Down function of the status register
- **Software Write Protection**
  - Write protection through Block-Protection bits in status register
- **Temperature Range**
  - Industrial: -40°C to +85°C
- **Packages Available**
  - 8-lead SOIC (200 mils)
  - 8-contact WSON (5 X 6 mm)
- **All devices are RoHS compliant**

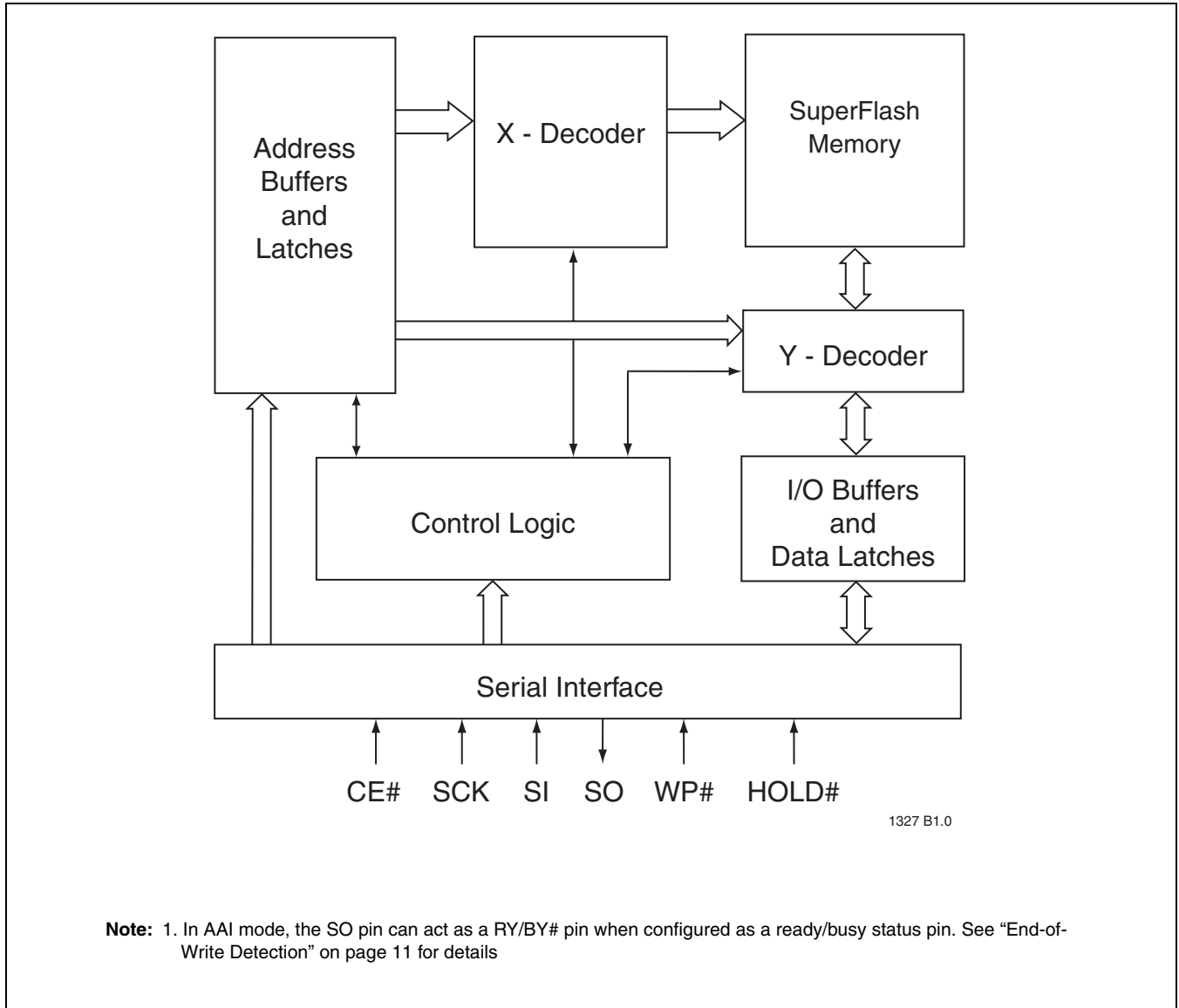
### PRODUCT DESCRIPTION

The PCT 25 series Serial Flash family features a four-wire, SPI-compatible interface that allows for a low pin-count package which occupies less board space and ultimately lowers total system costs. PCT25VF032B SPI serial flash memories are manufactured with SST's proprietary, high-performance CMOS SuperFlash technology. The split-gate cell design and thick-oxide tunneling injector attain better reliability and manufacturability compared with alternate approaches.

The PCT25VF032B devices significantly improve performance and reliability, while lowering power consumption. The devices write (Program or Erase) with a single power

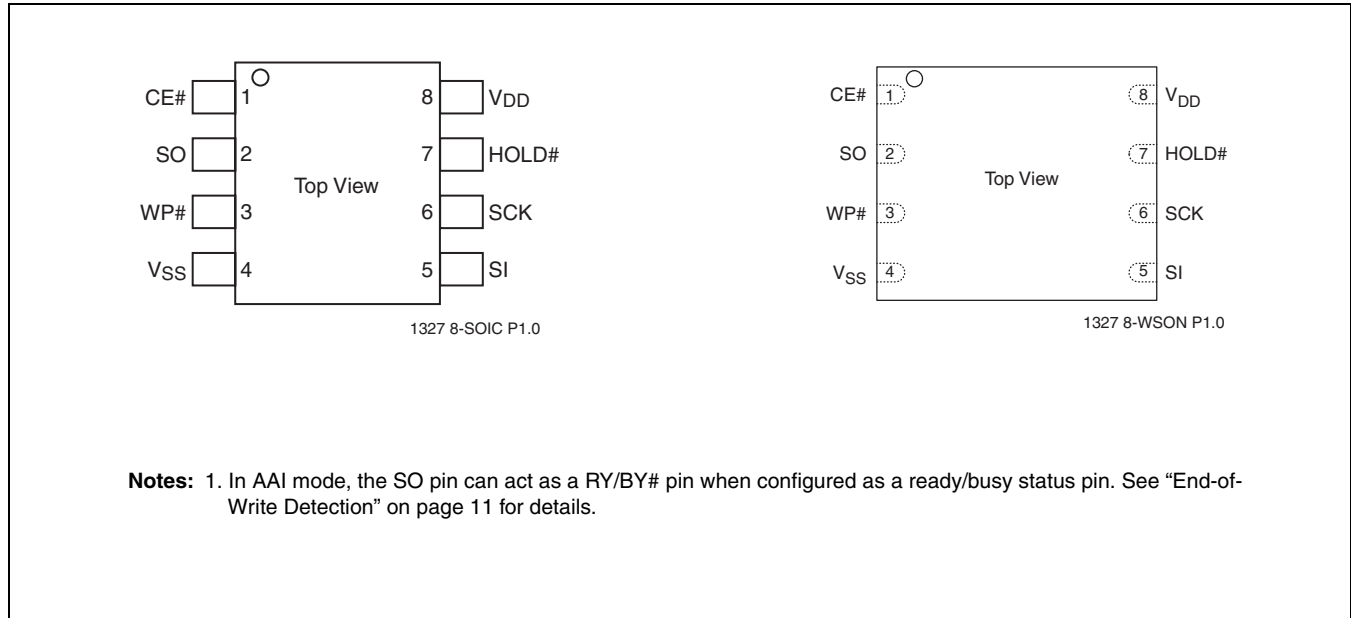
supply of 2.7-3.6V for PCT25VF032B. The total energy consumed is a function of the applied voltage, current, and time of application. Since for any given voltage range, the SuperFlash technology uses less current to program and has a shorter erase time, the total energy consumed during any Erase or Program operation is less than alternative flash memory technologies.

The PCT25VF032B device is offered in 8-lead SOIC (200 mils) and 8-contact WSON packages. See Figure 2 for pin assignments.



**FIGURE 1: Functional Block Diagram**

**PIN DESCRIPTION**



**FIGURE 2: Pin Assignments for 8-Lead SOIC**

**TABLE 1: Pin Description**

Symbol	Pin Name	Functions
SCK	Serial Clock	To provide the timing of the serial interface. Commands, addresses, or input data are latched on the rising edge of the clock input, while output data is shifted out on the falling edge of the clock input.
SI	Serial Data Input	To transfer commands, addresses, or data serially into the device. Inputs are latched on the rising edge of the serial clock.
SO	Serial Data Output	To transfer data serially out of the device. Data is shifted out on the falling edge of the serial clock.
RY/BY#	Ready / Busy pin	Flash busy status pin in AAI mode if SO is configured as a hardware RY/BY# pin.
CE#	Chip Enable	The device is enabled by a high to low transition on CE#. CE# must remain low for the duration of any command sequence.
WP#	Write Protect	The Write Protect (WP#) pin is used to enable/disable BPL bit in the status register.
HOLD#	Hold	To temporarily stop serial communication with SPI flash memory without resetting the device.
V <sub>DD</sub>	Power Supply	To provide power supply voltage: 2.7-3.6V
V <sub>SS</sub>	Ground	

T1.0 1327

Data Sheet

**MEMORY ORGANIZATION**

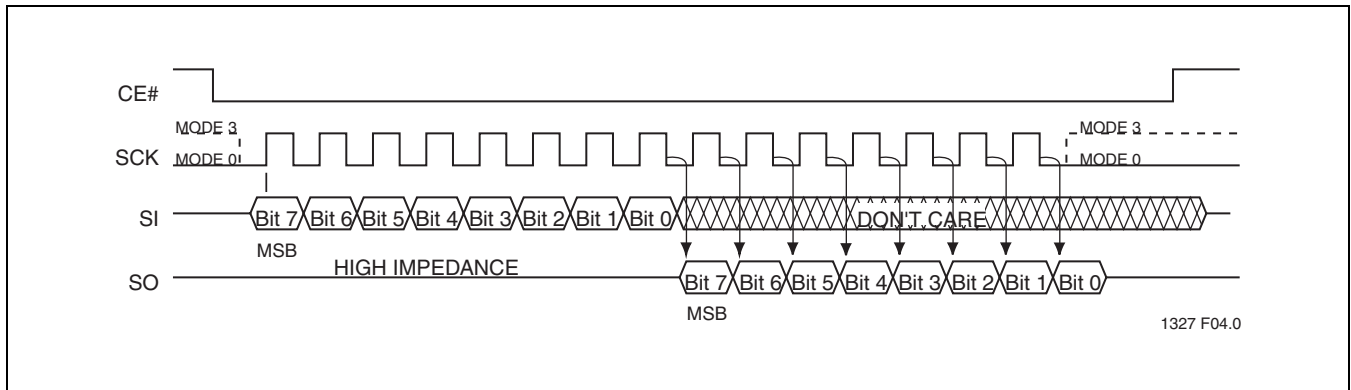
The ÚÔT25VF032B SuperFlash memory array is organized in uniform 4 KByte erasable sectors with 32 KByte overlay blocks and 64 KByte overlay erasable blocks.

**DEVICE OPERATION**

The ÚÔT25VF032B is accessed through the SPI (Serial Peripheral Interface) bus compatible protocol. The SPI bus consist of four control lines; Chip Enable (CE#) is used to

select the device, and data is accessed through the Serial Data Input (SI), Serial Data Output (SO), and Serial Clock (SCK).

The ÚÔT25VF032B supports both Mode 0 (0,0) and Mode 3 (1,1) of SPI bus operations. The difference between the two modes, as shown in Figure 3, is the state of the SCK signal when the bus master is in Stand-by mode and no data is being transferred. The SCK signal is low for Mode 0 and SCK signal is high for Mode 3. For both modes, the Serial Data In (SI) is sampled at the rising edge of the SCK clock signal and the Serial Data Output (SO) is driven after the falling edge of the SCK clock signal.



**FIGURE 3: SPI Protocol**

### Hold Operation

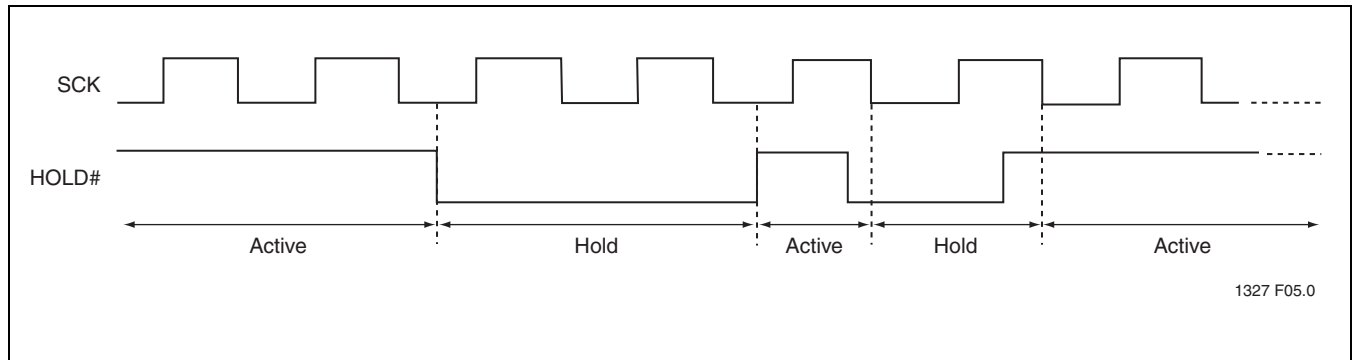
The HOLD# pin is used to pause a serial sequence using the SPI flash memory, but without resetting the clocking sequence. To activate the HOLD# mode, CE# must be in active low state. The HOLD# mode begins when the SCK active low state coincides with the falling edge of the HOLD# signal. The HOLD mode ends when the HOLD# signal's rising edge coincides with the SCK active low state.

If the falling edge of the HOLD# signal does not coincide with the SCK active low state, then the device enters Hold mode when the SCK next reaches the active low state. Similarly, if the rising edge of the HOLD# signal does not

coincide with the SCK active low state, then the device exits from Hold mode when the SCK next reaches the active low state. See Figure 4 for Hold Condition waveform.

Once the device enters Hold mode, SO will be in high-impedance state while SI and SCK can be  $V_{IL}$  or  $V_{IH}$ .

If CE# is driven high during a Hold condition, the device returns to Standby mode. As long as HOLD# signal is low, the memory remains in the Hold condition. To resume communication with the device, HOLD# must be driven active high, and CE# must be driven active low. See Figure 4 for Hold timing.



**FIGURE 4: Hold Condition Waveform**

### Write Protection

ÚÔT25VF032B provides software Write protection. The Write Protect pin (WP#) enables or disables the lock-down function of the status register. The Block-Protection bits (BP3, BP2, BP1, BP0, and BPL) in the status register provide Write protection to the memory array and the status register. See Table 4 for the Block-Protection description.

#### Write Protect Pin (WP#)

The Write Protect (WP#) pin enables the lock-down function of the BPL bit (bit 7) in the status register. When WP# is driven low, the execution of the Write-Status-Register (WRSR) instruction is determined by the value of the BPL bit (see Table 2). When WP# is high, the lock-down function of the BPL bit is disabled.

**TABLE 2: Conditions to execute Write-Status-Register (WRSR) Instruction**

WP#	BPL	Execute WRSR Instruction
L	1	Not Allowed
L	0	Allowed
H	X	Allowed

T2.0 1327

## Status Register

The software status register provides status on whether the flash memory array is available for any Read or Write operation, whether the device is Write enabled, and the state of the Memory Write protection. During an internal Erase or

Program operation, the status register may be read only to determine the completion of an operation in progress. Table 3 describes the function of each bit in the software status register.

**TABLE 3: Software Status Register**

Bit	Name	Function	Default at Power-up	Read/Write
0	BUSY	1 = Internal Write operation is in progress 0 = No internal Write operation is in progress	0	R
1	WEL	1 = Device is memory Write enabled 0 = Device is not memory Write enabled	0	R
2	BP0	Indicate current level of block write protection (See Table 4)	1	R/W
3	BP1	Indicate current level of block write protection (See Table 4)	1	R/W
4	BP2	Indicate current level of block write protection (See Table 4)	1	R/W
5	BP3	Indicate current level of block write protection (See Table 4)	0	R/W
6	AAI	Auto Address Increment Programming status 1 = AAI programming mode 0 = Byte-Program mode	0	R
7	BPL	1 = BP3, BP2, BP1, BP0 are read-only bits 0 = BP3, BP2, BP1, BP0 are readable/writable	0	R/W

T3.0 1327

### Busy

The Busy bit determines whether there is an internal Erase or Program operation in progress. A '1' for the Busy bit indicates the device is busy with an operation in progress. A '0' indicates the device is ready for the next valid operation.

### Auto Address Increment (AAI)

The Auto Address Increment Programming-Status bit provides status on whether the device is in AAI programming mode or Byte-Program mode. The default at power up is Byte-Program mode.

### Write Enable Latch (WEL)

The Write-Enable-Latch bit indicates the status of the internal memory Write Enable Latch. If the Write-Enable-Latch bit is set to '1', it indicates the device is Write enabled. If the bit is set to '0' (reset), it indicates the device is not Write enabled and does not accept any memory Write (Program/Erase) commands. The Write-Enable-Latch bit is automatically reset under the following conditions:

- Power-up
- Write-Disable (WRDI) instruction completion
- Byte-Program instruction completion
- Auto Address Increment (AAI) programming is completed or reached its highest unprotected memory address
- Sector-Erase instruction completion
- Block-Erase instruction completion
- Chip-Erase instruction completion
- Write-Status-Register instructions

## 32 Mbit SPI Serial Flash D7 T25VF032B



Data Sheet

### Block Protection (BP3, BP2, BP1, BP0)

The Block-Protection (BP3, BP2, BP1, BP0) bits define the size of the memory area, as shown in Table 4, to be software protected against any memory Write (Program or Erase) operation. The Write-Status-Register (WRSR) instruction is used to program the BP3, BP2, BP1 and BP0 bits as long as WP# is high or the Block-Protect-Lock (BPL) bit is 0. Chip-Erase can only be executed if Block-Protection bits are all 0. After power-up, BP3, BP2, BP1 and BP0 are set to the defaults specified in Table 4.

### Block Protection Lock-Down (BPL)

WP# pin driven low ( $V_{IL}$ ), enables the Block-Protection-Lock-Down (BPL) bit. When BPL is set to 1, it prevents any further alteration of the BPL, BP3, BP2, BP1, and BP0 bits. When the WP# pin is driven high ( $V_{IH}$ ), the BPL bit has no effect and its value is "Don't Care". After power-up, the BPL bit is reset to 0.

**TABLE 4: Software Status Register Block Protection FOR PCT25VF032B<sup>1</sup>**

Protection Level	Status Register Bit <sup>2</sup>				Protected Memory Address
	BP3	BP2	BP1	BP0	32 Mbit
None	X	0	0	0	None
Upper 1/64	X	0	0	1	3F0000H-3FFFFFFH
Upper 1/32	X	0	1	0	3E0000H-3FFFFFFH
Upper 1/16	X	0	1	1	3C0000H-3FFFFFFH
Upper 1/8	X	1	0	0	380000H-3FFFFFFH
Upper 1/4	X	1	0	1	300000H-3FFFFFFH
Upper 1/2	X	1	1	0	200000H-3FFFFFFH
All Blocks	X	1	1	1	000000H-3FFFFFFH

T4.0 1327

1. X = Don't Care (RESERVED) default is "0"
2. Default at power-up for BP2, BP1, and BP0 is '111'. (All Blocks Protected)

## Data Sheet

### INSTRUCTIONS

Instructions are used to read, write (Erase and Program), and configure the PCT25VF032B. The instruction bus cycles are 8 bits each for commands (Op Code), data, and addresses. The Write-Enable (WREN) instruction must be executed prior any Byte-Program, Auto Address Increment (AAI) programming, Sector-Erase, Block-Erase, Write-Status-Register, or Chip-Erase instructions. The complete list of instructions is provided in Table 5.

All instructions are synchronized off a high to low transition of CE#. Inputs will be accepted on the rising edge of SCK starting with the most significant bit. CE# must be driven

low before an instruction is entered and must be driven high after the last bit of the instruction has been shifted in (except for Read, Read-ID, and Read-Status-Register instructions). Any low to high transition on CE#, before receiving the last bit of an instruction bus cycle, will terminate the instruction in progress and return the device to standby mode. Instruction commands (Op Code), addresses, and data are all input from the most significant bit (MSB) first.

**TABLE 5: Device Operation Instructions**

Instruction	Description	Op Code Cycle <sup>1</sup>	Address Cycle(s) <sup>2</sup>	Dummy Cycle(s)	Data Cycle(s)	Maximum Frequency
Read	Read Memory	0000 0011b (03H)	3	0	1 to ∞	25 MHz
High-Speed Read	Read Memory at higher speed	0000 1011b (0BH)	3	1	1 to ∞	80 MHz
4 KByte Sector-Erase <sup>3</sup>	Erase 4 KByte of memory array	0010 0000b (20H)	3	0	0	80 MHz
32 KByte Block-Erase <sup>4</sup>	Erase 32KByte block of memory array	0101 0010b (52H)	3	0	0	80 MHz
64 KByte Block-Erase <sup>5</sup>	Erase 64 KByte block of memory array	1101 1000b (D8H)	3	0	0	80 MHz
Chip-Erase	Erase Full Memory Array	0110 0000b (60H) or 1100 0111b (C7H)	0	0	0	80 MHz
Byte-Program	To Program One Data Byte	0000 0010b (02H)	3	0	1	80 MHz
AAI-Word-Program <sup>6</sup>	Auto Address Increment Programming	1010 1101b (ADH)	3	0	2 to ∞	80 MHz
RDSR <sup>7</sup>	Read-Status-Register	0000 0101b (05H)	0	0	1 to ∞	80 MHz
EWSR	Enable-Write-Status-Register	0101 0000b (50H)	0	0	0	80 MHz
WRSR	Write-Status-Register	0000 0001b (01H)	0	0	1	80 MHz
WREN	Write-Enable	0000 0110b (06H)	0	0	0	80 MHz
WRDI	Write-Disable	0000 0100b (04H)	0	0	0	80 MHz
RDID <sup>8</sup>	Read-ID	1001 0000b (90H) or 1010 1011b (ABH)	3	0	1 to ∞	80 MHz
JEDEC-ID	JEDEC ID read	1001 1111b (9FH)	0	0	3 to ∞	80 MHz
EBSY	Enable SO as an output RY/BY# status during AAI programming	0111 0000b (70H)	0	0	0	80 MHz
DBSY	Disable SO as an output RY/BY# status during AAI programming	1000 0000b (80H)	0	0	0	80 MHz

T5.0 1327

- One bus cycle is eight clock periods.
- Address bits above the most significant bit can be either V<sub>IL</sub> or V<sub>IH</sub>.
- 4KByte Sector Erase addresses: use A<sub>MS</sub>-A<sub>12</sub>, remaining addresses are don't care but must be set either at V<sub>IL</sub> or V<sub>IH</sub>.
- 32KByte Block Erase addresses: use A<sub>MS</sub>-A<sub>15</sub>, remaining addresses are don't care but must be set either at V<sub>IL</sub> or V<sub>IH</sub>.
- 64KByte Block Erase addresses: use A<sub>MS</sub>-A<sub>16</sub>, remaining addresses are don't care but must be set either at V<sub>IL</sub> or V<sub>IH</sub>.
- To continue programming to the next sequential address location, enter the 8-bit command, ADH, followed by 2 bytes of data to be programmed. Data Byte 0 will be programmed into the initial address [A<sub>23</sub>-A<sub>1</sub>] with A<sub>0</sub>=0, Data Byte 1 will be programmed into the initial address [A<sub>23</sub>-A<sub>1</sub>] with A<sub>0</sub> = 1.
- The Read-Status-Register is continuous with ongoing clock cycles until terminated by a low to high transition on CE#.
- Manufacturer's ID is read with A<sub>0</sub> = 0, and Device ID is read with A<sub>0</sub> = 1. All other address bits are 00H. The Manufacturer's ID and device ID output stream is continuous until terminated by a low-to-high transition on CE#.

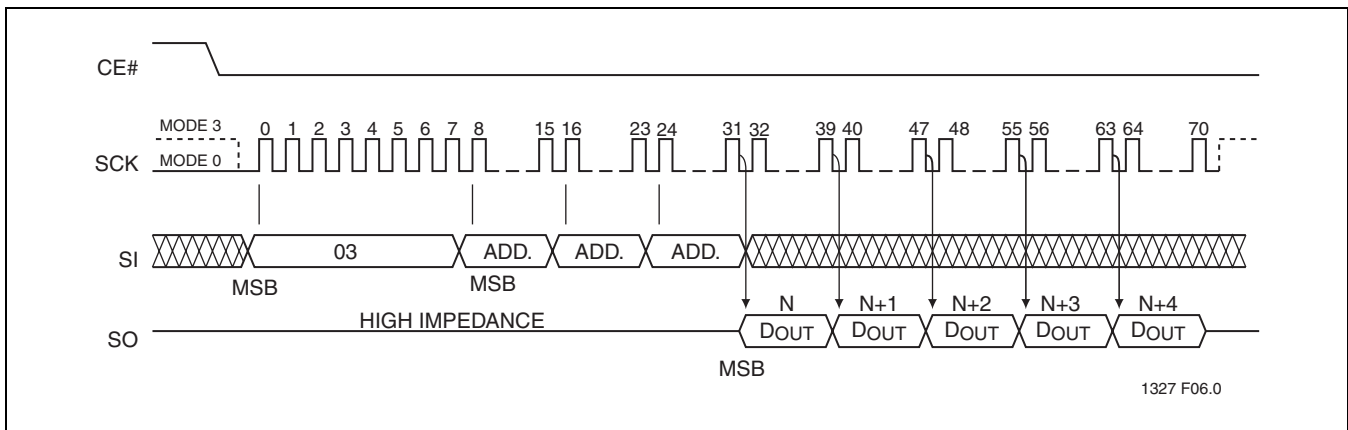


**Read (25 MHz)**

The Read instruction, 03H, supports up to 25 MHz Read. The device outputs the data starting from the specified address location. The data output stream is continuous through all addresses until terminated by a low to high transition on CE#. The internal address pointer will automatically increment until the highest memory address is reached. Once the highest memory address is reached, the address pointer will automatically increment to the beginning (wrap-around) of the address space. For exam-

ple, once the data from address location 3FFFFFFH has been read, the next output will be from address location 000000H.

The Read instruction is initiated by executing an 8-bit command, 03H, followed by address bits [A<sub>23</sub>-A<sub>0</sub>]. CE# must remain active low for the duration of the Read cycle. See Figure 5 for the Read sequence.



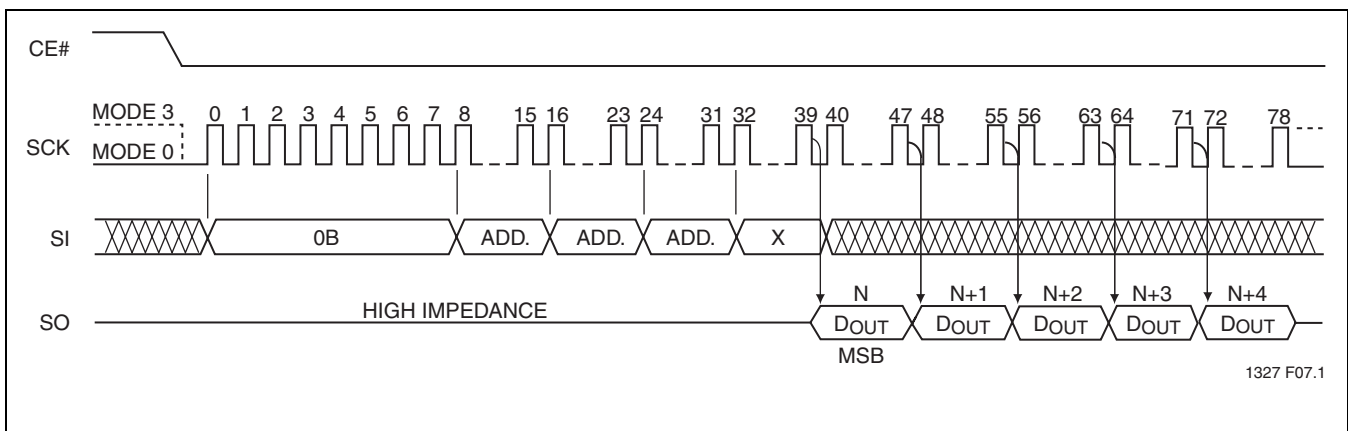
**FIGURE 5: Read Sequence**

**High-Speed-Read (80 MHz)**

The High-Speed-Read instruction supporting up to 80 MHz Read is initiated by executing an 8-bit command, 0BH, followed by address bits [A<sub>23</sub>-A<sub>0</sub>] and a dummy byte. CE# must remain active low for the duration of the High-Speed-Read cycle. See Figure 6 for the High-Speed-Read sequence.

Following a dummy cycle, the High-Speed-Read instruction outputs the data starting from the specified address location. The data output stream is continuous through all

addresses until terminated by a low to high transition on CE#. The internal address pointer will automatically increment until the highest memory address is reached. Once the highest memory address is reached, the address pointer will automatically increment to the beginning (wrap-around) of the address space. For example, once the data from address location 3FFFFFFH has been read, the next output will be from address location 000000H.



**FIGURE 6: High-Speed-Read Sequence**

### Byte-Program

The Byte-Program instruction programs the bits in the selected byte to the desired data. The selected byte must be in the erased state (FFH) when initiating a Program operation. A Byte-Program instruction applied to a protected memory area will be ignored.

Prior to any Write operation, the Write-Enable (WREN) instruction must be executed. CE# must remain active low for the duration of the Byte-Program instruction. The Byte-

Program instruction is initiated by executing an 8-bit command, 02H, followed by address bits [A<sub>23</sub>-A<sub>0</sub>]. Following the address, the data is input in order from MSB (bit 7) to LSB (bit 0). CE# must be driven high before the instruction is executed. The user may poll the Busy bit in the software status register or wait T<sub>BP</sub> for the completion of the internal self-timed Byte-Program operation. See Figure 7 for the Byte-Program sequence.

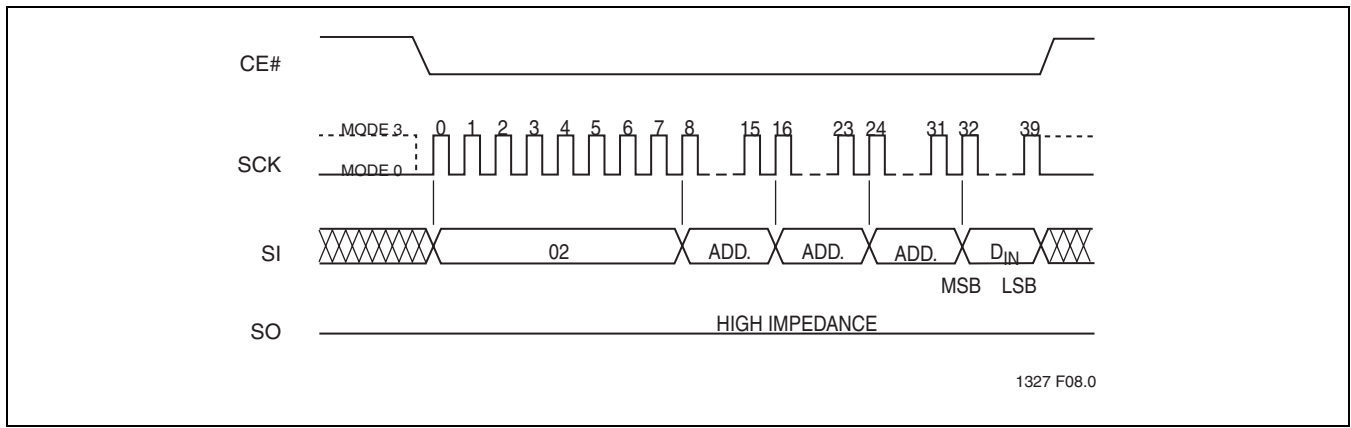


FIGURE 7: Byte-Program Sequence

### Auto Address Increment (AAI) Word-Program

The AAI program instruction allows multiple bytes of data to be programmed without re-issuing the next sequential address location. This feature decreases total programming time when multiple bytes or entire memory array is to be programmed. An AAI Word program instruction pointing to a protected memory area will be ignored. The selected address range must be in the erased state (FFH) when initiating an AAI Word Program operation. While within AAI Word Programming sequence, the only valid instructions are AAI Word (ADH), RDSR (05H), or WRDI (04H). Users have three options to determine the completion of each AAI Word program cycle: hardware detection by reading the Serial Output, software detection by polling the BUSY bit in the software status register or wait  $T_{BP}$ . Refer to End-Of-Write Detection section for details.

Prior to any write operation, the Write-Enable (WREN) instruction must be executed. The AAI Word Program instruction is initiated by executing an 8-bit command, ADH, followed by address bits  $[A_{23}-A_0]$ . Following the addresses, two bytes of data is input sequentially, each one from MSB (Bit 7) to LSB (Bit 0). The first byte of data (D0) will be programmed into the initial address  $[A_{23}-A_1]$  with  $A_0 = 0$ , the second byte of Data (D1) will be programmed into the initial address  $[A_{23}-A_1]$  with  $A_0 = 1$ . CE# must be driven high before the AAI Word Program instruction is executed. The user must check the BUSY status before entering the next valid command. Once the device indicates it is no longer busy, data for the next two sequential addresses may be programmed and so on. When the last desired byte had been entered, check the busy status using the hardware method or the RDSR instruction and execute the Write-Disable (WRDI) instruction, 04H, to terminate AAI. Check the busy status after WRDI to determine if the device is ready for any command. See Figures 10 and 11 for AAI Word programming sequence.

There is no wrap mode during AAI programming; once the highest unprotected memory address is reached, the device will exit AAI operation and reset the Write-Enable-Latch bit ( $WEL = 0$ ) and the AAI bit ( $AAI = 0$ ).

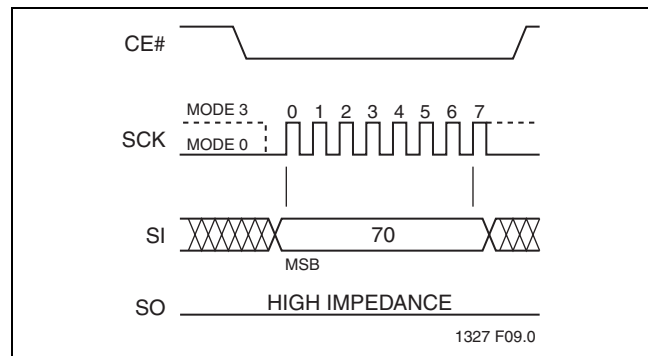
### End-of-Write Detection

There are three methods to determine completion of a program cycle during AAI Word programming: hardware detection by reading the Serial Output, software detection by polling the BUSY bit in the Software Status Register or wait  $T_{BP}$ . The hardware end-of-write detection method is described in the section below.

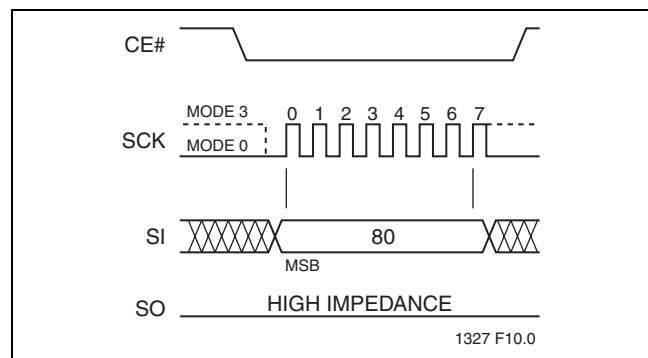
### Hardware End-of-Write Detection

The hardware end-of-write detection method eliminates the overhead of polling the Busy bit in the Software Status Register during an AAI Word program operation. The 8-bit command, 70H, configures the Serial Output (SO) pin to indicate Flash Busy status during AAI Word programming, as shown in Figure 8. The 8-bit command, 70H, must be executed prior to executing an AAI Word-Program instruction. Once an internal programming operation begins, asserting CE# will immediately drive the status of the internal flash status on the SO pin. A '0' indicates the device is busy and a '1' indicates the device is ready for the next instruction. De-asserting CE# will return the SO pin to tri-state.

The 8-bit command, 80H, prevents the Serial Output (SO) pin from outputting Busy status during AAI-Word-program operation and re-configures SO as an output pin. The device can only accept the 80H command when the device is not in AAI mode. Once SO is an output pin, in AAI mode the device can accept both RDSR instruction for polling and Software Status Register data outputs through the SO pin. This is shown in Figure 9.

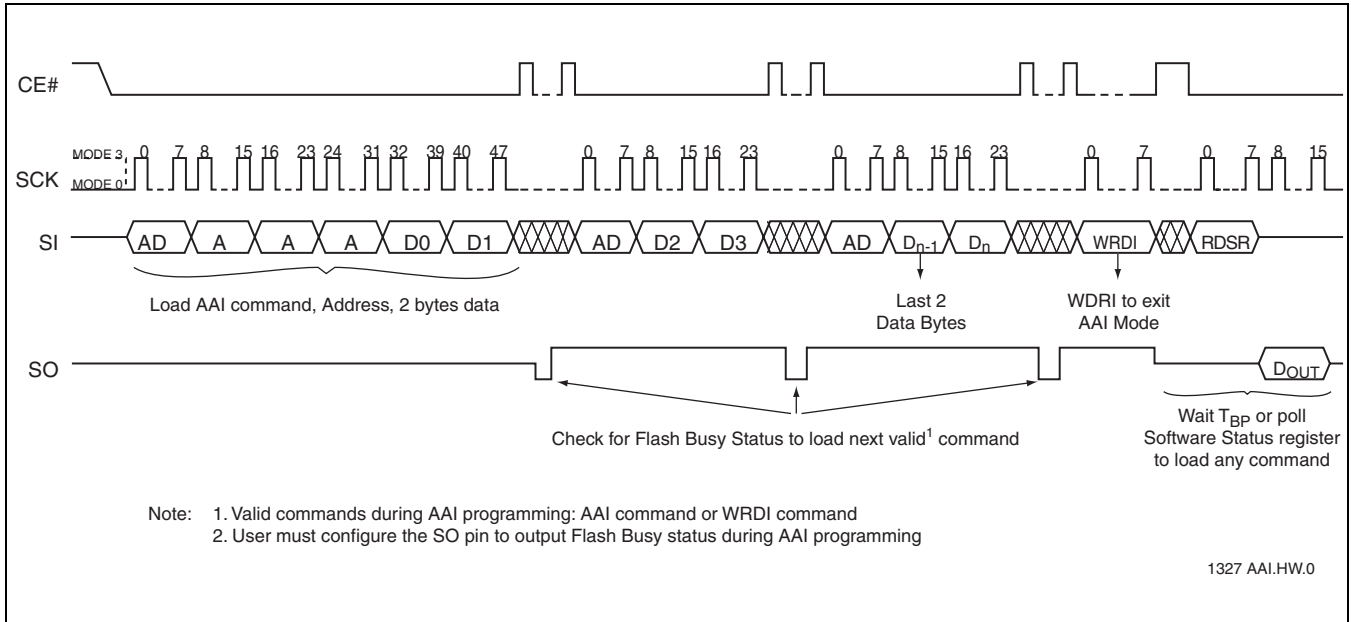


**FIGURE 8: Enable SO as Hardware RY/BY# during AAI Programming**

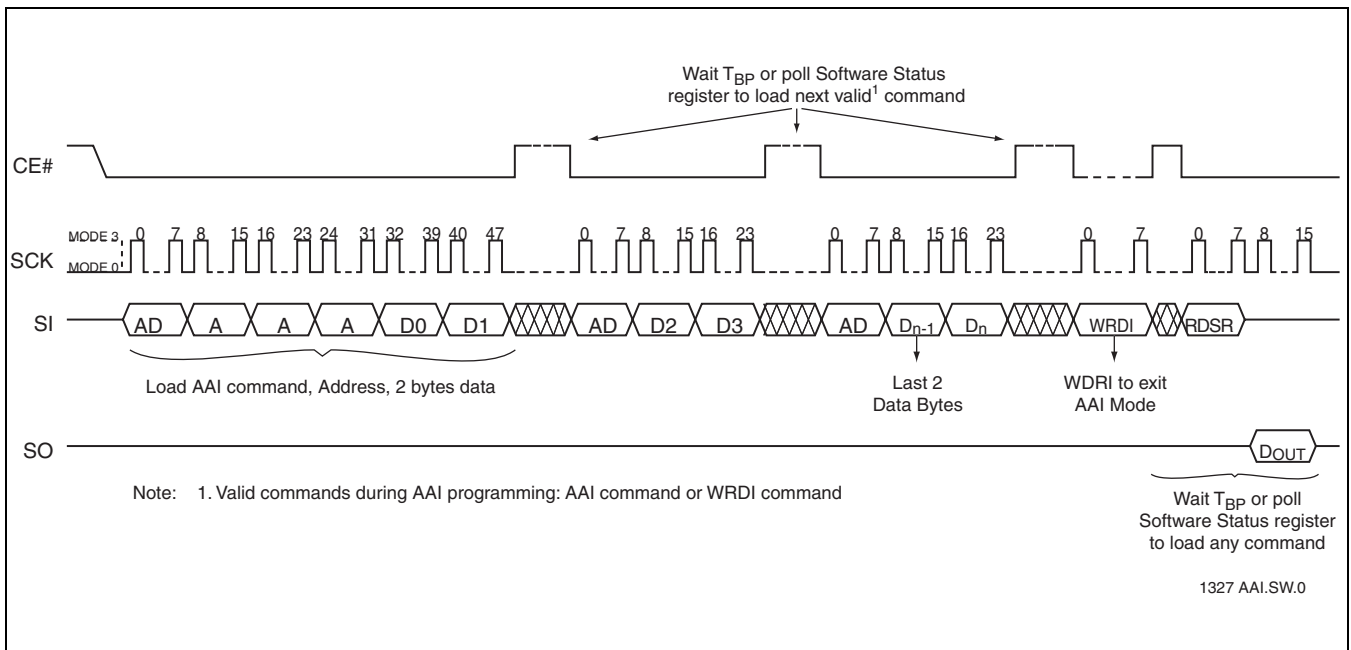


**FIGURE 9: Disable SO as Hardware RY/BY# during AAI Programming**

Data Sheet



**FIGURE 10: Auto Address Increment (AAI) Word-Program Sequence with Hardware End-of-Write Detection**

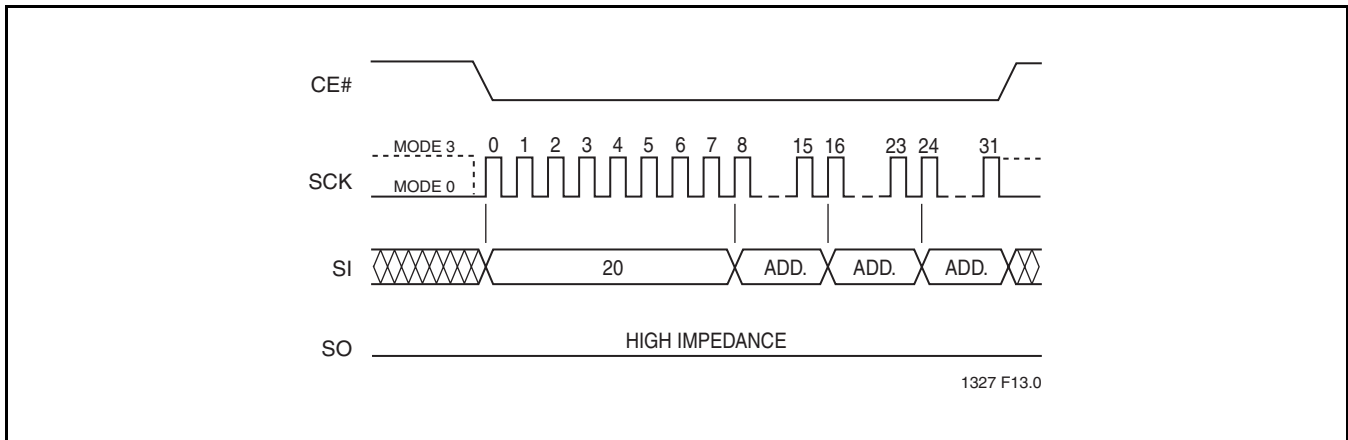


**FIGURE 11: Auto Address Increment (AAI) Word-Program Sequence with Software End-of-Write Detection**

**Sector-Erase**

The Sector-Erase instruction clears all bits in the selected 4 KByte sector to FFH. A Sector-Erase instruction applied to a protected memory area will be ignored. Prior to any Write operation, the Write-Enable (WREN) instruction must be executed. CE# must remain active low for the duration of any command sequence. The Sector-Erase instruction is initiated by executing an 8-bit command, 20H, followed by

address bits [A<sub>23</sub>-A<sub>0</sub>]. Address bits [A<sub>MS</sub>-A<sub>12</sub>] (A<sub>MS</sub> = Most Significant address) are used to determine the sector address (SA<sub>X</sub>), remaining address bits can be V<sub>IL</sub> or V<sub>IH</sub>. CE# must be driven high before the instruction is executed. Poll the Busy bit in the software status register or wait T<sub>SE</sub> for the completion of the internal self-timed Sector-Erase cycle. See Figure 12 for the Sector-Erase sequence.



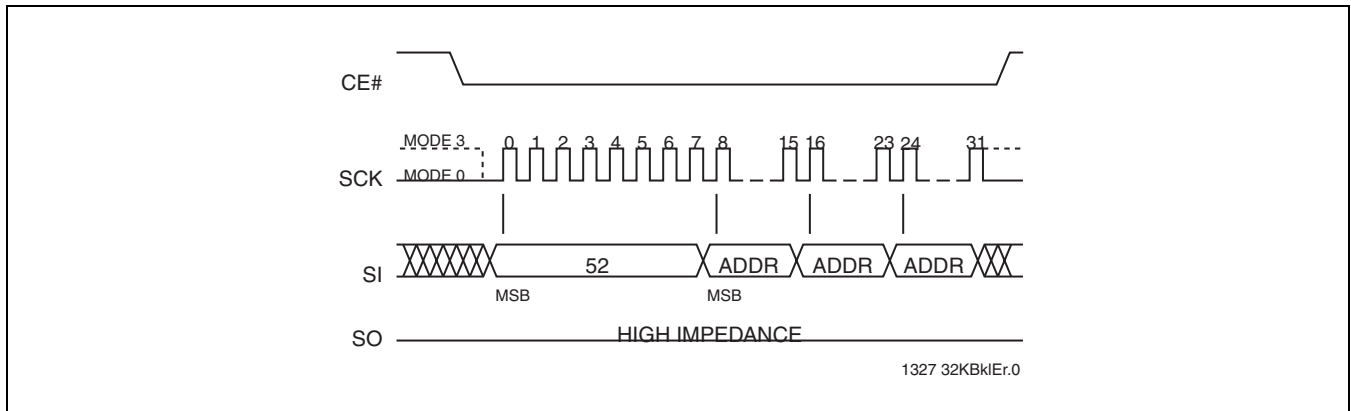
**FIGURE 12: Sector-Erase Sequence**

Data Sheet

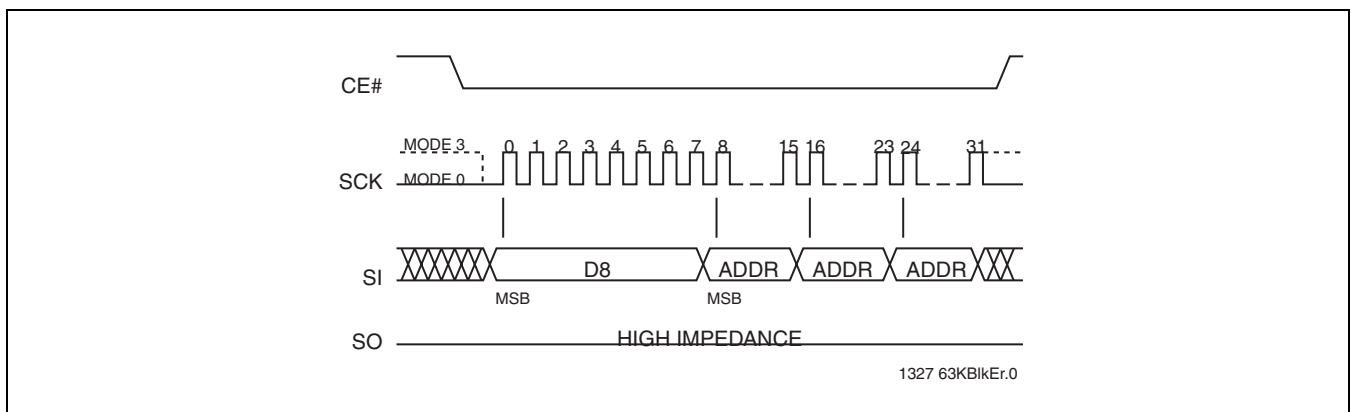
**32-KByte and 64-KByte Block-Erase**

The 32-KByte Block-Erase instruction clears all bits in the selected 32 KByte block to FFH. A Block-Erase instruction applied to a protected memory area will be ignored. The 64-KByte Block-Erase instruction clears all bits in the selected 64 KByte block to FFH. A Block-Erase instruction applied to a protected memory area will be ignored. Prior to any Write operation, the Write-Enable (WREN) instruction must be executed. CE# must remain active low for the duration of any command sequence. The 32-Kbyte Block-Erase instruction is initiated by executing an 8-bit command, 52H, followed by address bits [A<sub>23</sub>-A<sub>0</sub>]. Address bits [A<sub>MS</sub>-A<sub>15</sub>] (A<sub>MS</sub> = Most Significant Address) are used to

determine block address (BA<sub>X</sub>), remaining address bits can be V<sub>IL</sub> or V<sub>IH</sub>. CE# must be driven high before the instruction is executed. The 64-Kbyte Block-Erase instruction is initiated by executing an 8-bit command D8H, followed by address bits [A<sub>23</sub>-A<sub>0</sub>]. Address bits [A<sub>MS</sub>-A<sub>16</sub>] are used to determine block address (BA<sub>X</sub>), remaining address bits can be V<sub>IL</sub> or V<sub>IH</sub>. CE# must be driven high before the instruction is executed. Poll the Busy bit in the software status register or wait T<sub>BE</sub> for the completion of the internal self-timed 32-KByte Block-Erase or 64-KByte Block-Erase cycles. See Figure 13 for the 32-KByte Block-Erase sequence and Figure 14 for the 64-KByte Block-Erase sequence.



**FIGURE 13: 32-KByte Block-Erase Sequence**

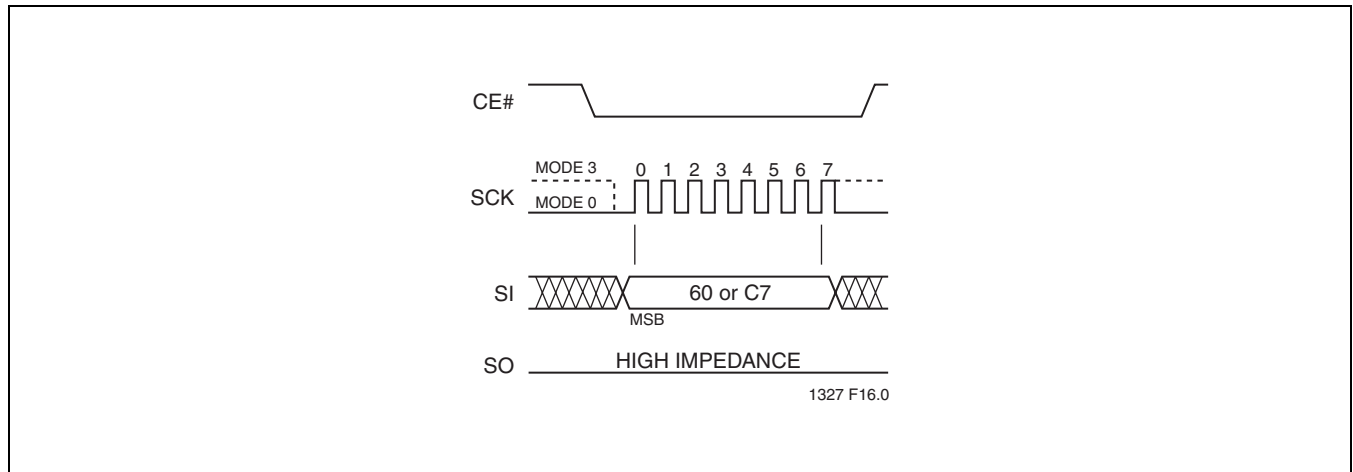


**FIGURE 14: 64-KByte Block-Erase Sequence**

**Chip-Erase**

The Chip-Erase instruction clears all bits in the device to FFH. A Chip-Erase instruction will be ignored if any of the memory area is protected. Prior to any Write operation, the Write-Enable (WREN) instruction must be executed. CE# must remain active low for the duration of the Chip-Erase instruction sequence. Initiate the Chip-Erase instruction by

executing an 8-bit command, 60H or C7H. CE# must be driven high before the instruction is executed. Poll the Busy bit in the software status register or wait T<sub>CE</sub> for the completion of the internal self-timed Chip-Erase cycle. See Figure 15 for the Chip-Erase sequence.

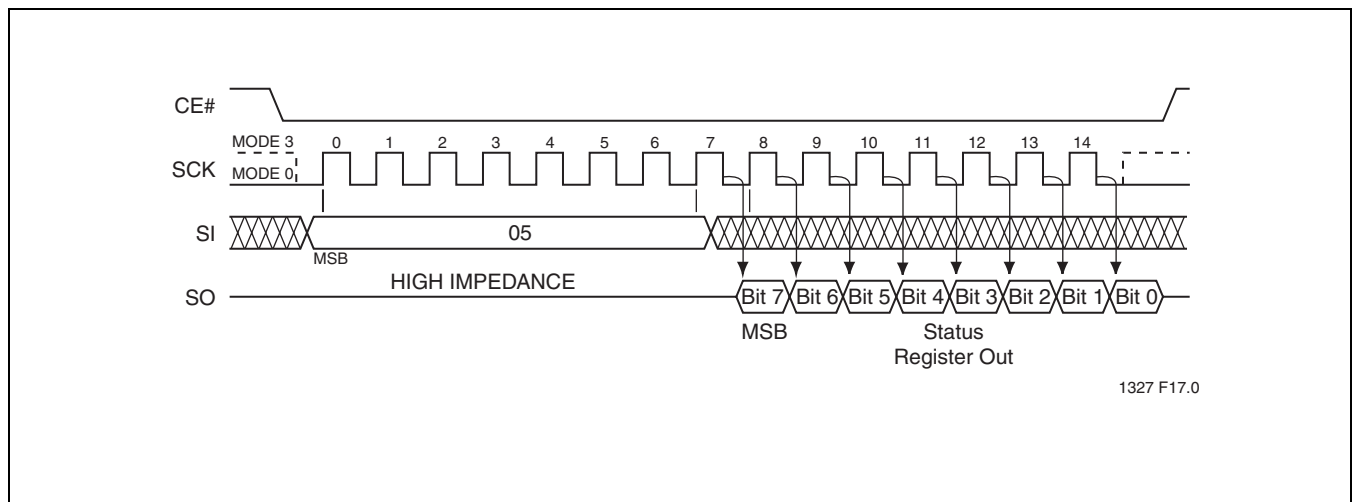


**FIGURE 15: Chip-Erase Sequence**

**Read-Status-Register (RDSR)**

The Read-Status-Register (RDSR) instruction allows reading of the status register. The status register may be read at any time even during a Write (Program/Erase) operation. When a Write operation is in progress, the Busy bit may be checked before sending any new commands to assure that the new commands are properly received by the device.

CE# must be driven low before the RDSR instruction is entered and remain low until the status data is read. Read-Status-Register is continuous with ongoing clock cycles until it is terminated by a low to high transition of the CE#. See Figure 16 for the RDSR instruction sequence.



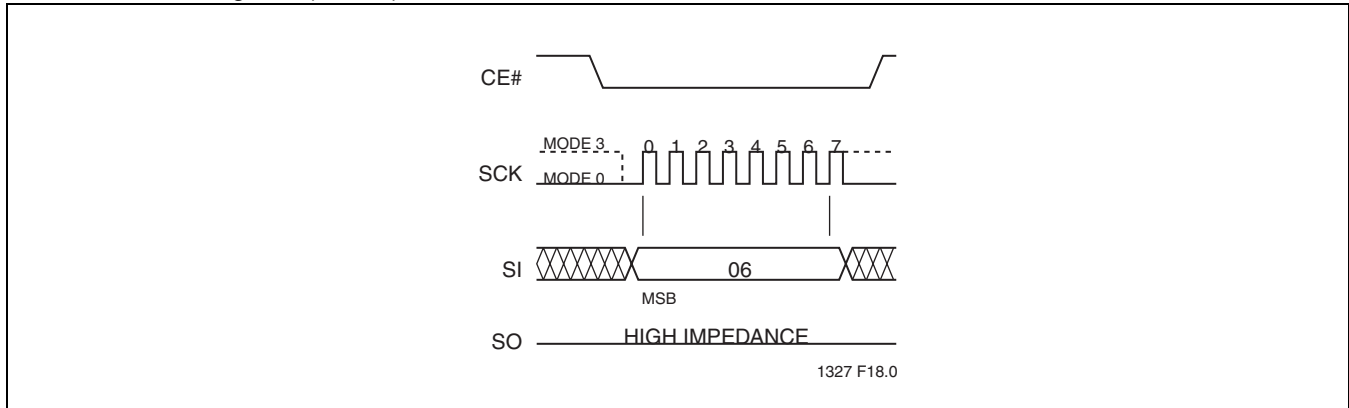
**FIGURE 16: Read-Status-Register (RDSR) Sequence**

Data Sheet

**Write-Enable (WREN)**

The Write-Enable (WREN) instruction sets the Write-Enable-Latch bit in the Status Register to '1' allowing Write operations to occur. The WREN instruction must be executed prior to any Write (Program/Erase) operation. The WREN instruction may also be used to allow execution of the Write-Status-Register (WRSR) instruction; however,

the Write-Enable-Latch bit in the Status Register will be cleared upon the rising edge CE# of the WRSR instruction. CE# must be driven high before the WREN instruction is executed.

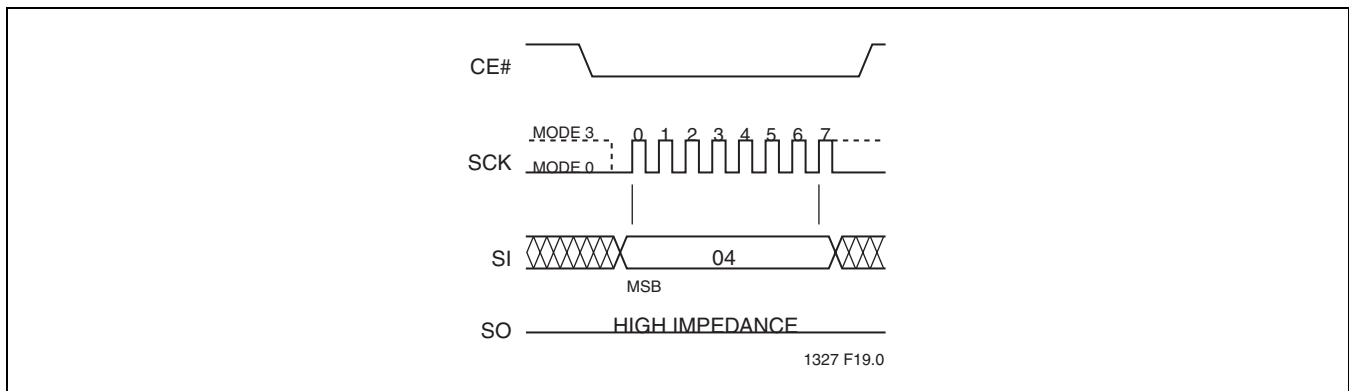


**FIGURE 17: Write Enable (WREN) Sequence**

**Write-Disable (WRDI)**

The Write-Disable (WRDI) instruction resets the Write-Enable-Latch bit and AAI bit to '0', therefore, preventing any new Write operations. The WRDI instruction will not terminate any programming operation in progress. Any program

operation in progress may continue up to  $T_{BP}$  after executing the WRDI instruction. CE# must be driven high before the WRDI instruction is executed.



**FIGURE 18: Write Disable (WRDI) Sequence**

**Enable-Write-Status-Register (EWSR)**

The Enable-Write-Status-Register (EWSR) instruction arms the Write-Status-Register (WRSR) instruction and opens the status register for alteration. The Write-Status-Register instruction must be executed immediately after the execution of the Enable-Write-Status-Register instruction. This two-step instruction sequence of the EWSR instruction followed by the WRSR instruction works like software data protection (SDP) command structure which prevents any accidental alteration of the status register values. CE#

must be driven low before the EWSR instruction is entered and must be driven high before the EWSR instruction is executed.

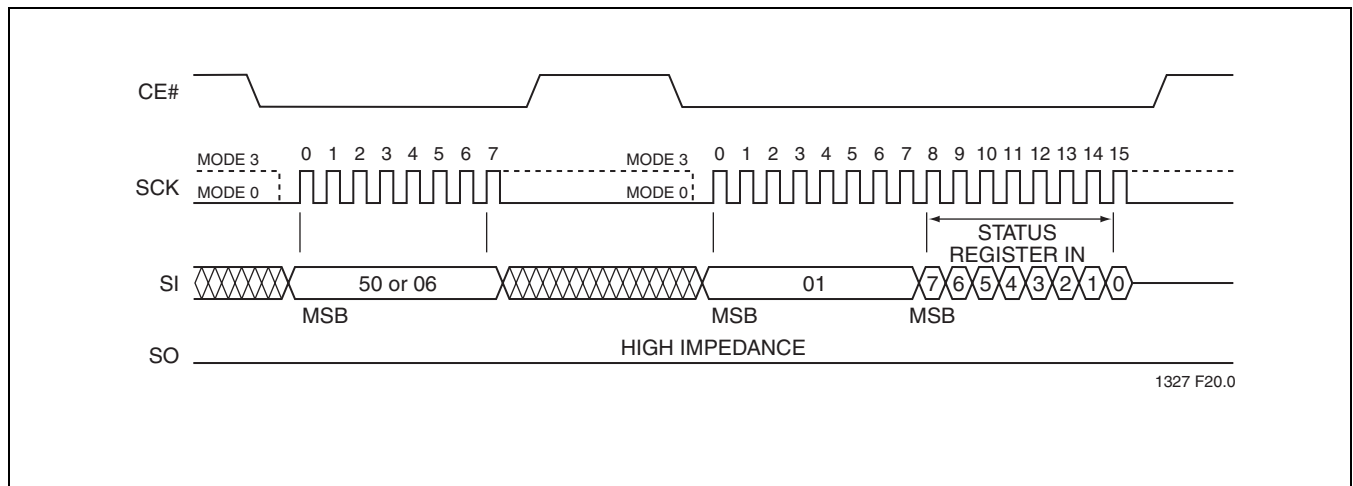


**Write-Status-Register (WRSR)**

The Write-Status-Register instruction writes new values to the BP3, BP2, BP1, BP0, and BPL bits of the status register. CE# must be driven low before the command sequence of the WRSR instruction is entered and driven high before the WRSR instruction is executed. See Figure 19 for EWSR or WREN and WRSR instruction sequences.

Executing the Write-Status-Register instruction will be ignored when WP# is low and BPL bit is set to '1'. When the WP# is low, the BPL bit can only be set from '0' to '1' to lock-down the status register, but cannot be reset from '1' to '0'. When WP# is high, the lock-down function of the BPL

bit is disabled and the BPL, BP0, and BP1 and BP2 bits in the status register can all be changed. As long as BPL bit is set to '0' or WP# pin is driven high (V<sub>IH</sub>) prior to the low-to-high transition of the CE# pin at the end of the WRSR instruction, the bits in the status register can all be altered by the WRSR instruction. In this case, a single WRSR instruction can set the BPL bit to '1' to lock down the status register as well as altering the BP0, BP1, and BP2 bits at the same time. See Table 2 for a summary description of WP# and BPL functions.



**FIGURE 19: Enable-Write-Status-Register (EWSR) or Write-Enable (WREN) and Write-Status-Register (WRSR) Sequence**

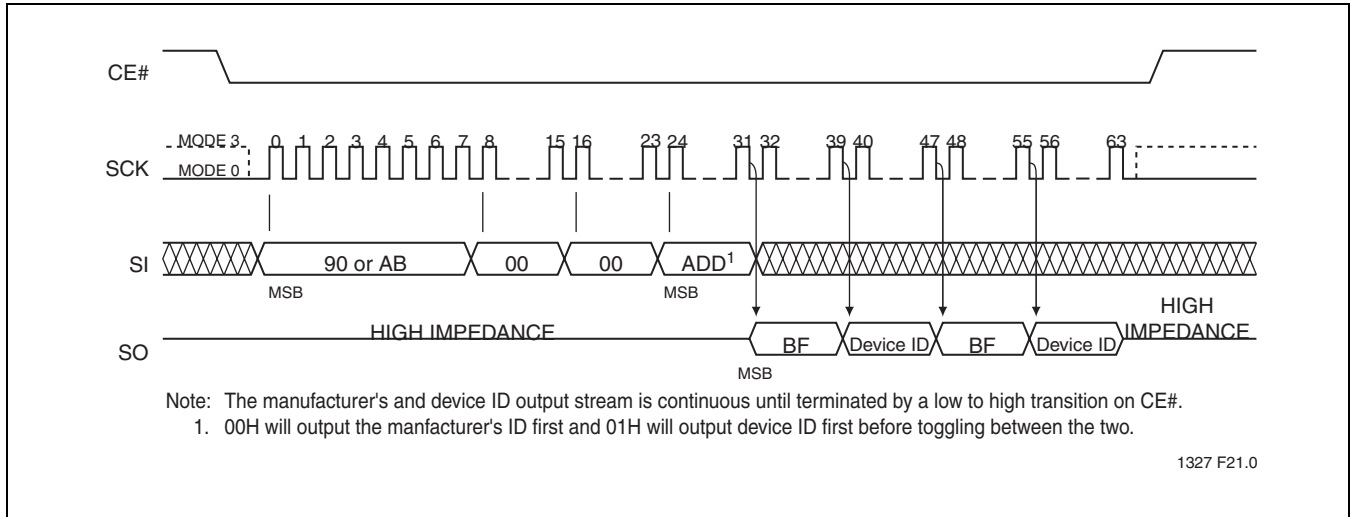
## Data Sheet

### Read-ID (RDID)

The Read-ID instruction (RDID) identifies the device as ÚÔT25VF032B and manufacturer as ÚÔT. The device information can be read from executing an 8-bit command, 90H or ABH, followed by address bits [A<sub>23</sub>-A<sub>0</sub>]. Following the Read-ID instruction, the manufacturer's ID is located in address 00000H and the device ID is located in address

00001H. Once the device is in Read-ID mode, the manufacturer's and device ID output data toggles between address 00000H and 00001H until terminated by a low to high transition on CE#.

Refer to Tables 6 and 7 for device identification data.



**FIGURE 20: Read-ID Sequence**

**TABLE 6: Product Identification**

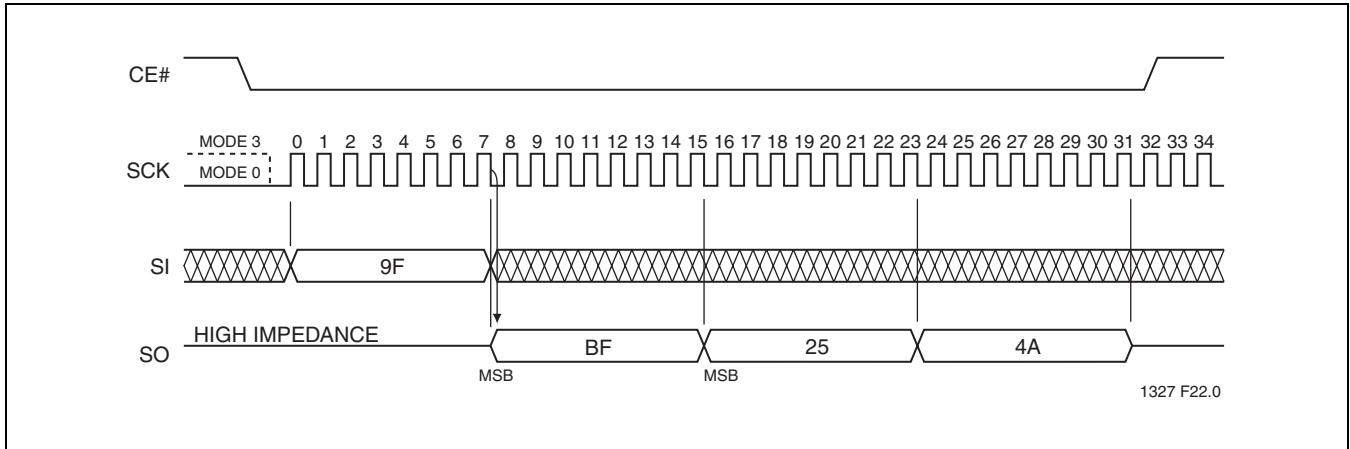
	Address	Data
Manufacturer's ID	00000H	BFH
Device ID	ÚÔT25VF032B/00001H	ÚÔT25VF032B/00001H

T6.0 1327

**JEDEC Read-ID**

The JEDEC Read-ID instruction identifies the device as ÚÔT25VF032B and the manufacturer as ÚÔT. The device information can be read from executing the 8-bit command, 9FH. Following the JEDEC Read-ID instruction, the 8-bit manufacturer's ID, BFH, is output from the device. After that, a 24-bit device ID is shifted out on the SO pin. Byte 1, BFH, identifies the manufacturer as ÚÔT. Byte 2, 25H, identifies the memory type as SPI Serial Flash. Byte 3, 4AH, identifies the device as ÚÔT25VF032B. The instruction sequence is shown in Figure 21. The JEDEC Read ID instruction is terminated by a low to high transition on CE# at any time during data output.

BFH, identifies the manufacturer as ÚÔT. Byte 2, 25H, identifies the memory type as SPI Serial Flash. Byte 3, 4AH, identifies the device as ÚÔT25VF032B. The instruction sequence is shown in Figure 21. The JEDEC Read ID instruction is terminated by a low to high transition on CE# at any time during data output.



**FIGURE 21: JEDEC Read-ID Sequence**

**TABLE 7: JEDEC Read-ID Data**

Manufacturer's ID	Device ID	
	Memory Type	Memory Capacity
Byte1	Byte 2	Byte 3
BFH	25H	4AH

T7.0 1327

**ELECTRICAL SPECIFICATIONS**

**Absolute Maximum Stress Ratings** Applied conditions greater than those listed under “Absolute Maximum Stress Ratings” may cause permanent damage to the device. This is a stress rating only and functional operation of the device at these conditions or conditions greater than those defined in the operational sections of this data sheet is not implied. Exposure to absolute maximum stress rating conditions may affect device reliability.

Temperature Under Bias . . . . .	-55°C to +125°C
Storage Temperature . . . . .	-65°C to +150°C
D. C. Voltage on Any Pin to Ground Potential . . . . .	-0.5V to V <sub>DD</sub> +0.5V
Transient Voltage (<20 ns) on Any Pin to Ground Potential . . . . .	-2.0V to V <sub>DD</sub> +2.0V
Package Power Dissipation Capability (T <sub>A</sub> = 25°C) . . . . .	1.0W
Surface Mount Solder Reflow Temperature . . . . .	260°C for 10 seconds
Output Short Circuit Current <sup>1</sup> . . . . .	50 mA

1. Output shorted for no more than one second. No more than one output shorted at a time.

**OPERATING RANGE**

Range	Ambient Temp	V <sub>DD</sub>
Industrial	-40°C to +85°C	2.7-3.6V

**AC CONDITIONS OF TEST**

Input Rise/Fall Time . . . . .	5 ns
Output Load . . . . .	C <sub>L</sub> = 30 pF
See Figure 26	

**TABLE 8: DC Operating Characteristics (V<sub>DD</sub> = 2.7-3.6V)**

Symbol	Parameter	Limits			Test Conditions
		Min	Max	Units	
I <sub>DDR</sub>	Read Current		10	mA	CE# = 0.1 V <sub>DD</sub> /0.9 V <sub>DD</sub> @25 MHz, SO = open
I <sub>DDR2</sub>	Read Current		20	mA	CE# = 0.1 V <sub>DD</sub> /0.9 V <sub>DD</sub> @66 MHz, SO = open
I <sub>DDR3</sub>	Read Current		25	mA	CE# = 0.1 V <sub>DD</sub> /0.9 V <sub>DD</sub> @80 MHz, SO = open
I <sub>DDW</sub>	Program and Erase Current		30	mA	CE# = V <sub>DD</sub>
I <sub>SB</sub>	Standby Current		20	µA	CE# = V <sub>DD</sub> , V <sub>IN</sub> = V <sub>DD</sub> or V <sub>SS</sub>
I <sub>LI</sub>	Input Leakage Current		1	µA	V <sub>IN</sub> = GND to V <sub>DD</sub> , V <sub>DD</sub> = V <sub>DD</sub> Max
I <sub>LO</sub>	Output Leakage Current		1	µA	V <sub>OUT</sub> = GND to V <sub>DD</sub> , V <sub>DD</sub> = V <sub>DD</sub> Max
V <sub>IL</sub>	Input Low Voltage		0.8	V	V <sub>DD</sub> = V <sub>DD</sub> Min
V <sub>IH</sub>	Input High Voltage	0.7 V <sub>DD</sub>		V	V <sub>DD</sub> = V <sub>DD</sub> Max
V <sub>OL</sub>	Output Low Voltage		0.2	V	I <sub>OL</sub> = 100 µA, V <sub>DD</sub> = V <sub>DD</sub> Min
V <sub>OL2</sub>	Output Low Voltage		0.4	V	I <sub>OL</sub> = 1.6 mA, V <sub>DD</sub> = V <sub>DD</sub> Min
V <sub>OH</sub>	Output High Voltage	V <sub>DD</sub> -0.2		V	I <sub>OH</sub> = -100 µA, V <sub>DD</sub> = V <sub>DD</sub> Min

T8.0 1327

**TABLE 9: Recommended System Power-up Timings**

Symbol	Parameter	Minimum	Units
T <sub>PU-READ</sub> <sup>1</sup>	V <sub>DD</sub> Min to Read Operation	100	µs
T <sub>PU-WRITE</sub> <sup>1</sup>	V <sub>DD</sub> Min to Write Operation	100	µs

T9.0 1327

1. This parameter is measured only for initial qualification and after a design or process change that could affect this parameter.

# 32 Mbit SPI Serial Flash

## D7 T25VF032B



Data Sheet

**TABLE 10: Capacitance** ( $T_A = 25^\circ\text{C}$ ,  $f = 1\text{ Mhz}$ , other pins open)

Parameter	Description	Test Condition	Maximum
$C_{OUT}^1$	Output Pin Capacitance	$V_{OUT} = 0V$	12 pF
$C_{IN}^1$	Input Capacitance	$V_{IN} = 0V$	6 pF

T10.0 1327

1. This parameter is measured only for initial qualification and after a design or process change that could affect this parameter.

**TABLE 11: Reliability Characteristics**

Symbol	Parameter	Minimum Specification	Units	Test Method
$N_{END}^1$	Endurance	10,000	Cycles	JEDEC Standard A117
$T_{DR}^1$	Data Retention	100	Years	JEDEC Standard A103
$I_{LTH}^1$	Latch Up	$100 + I_{DD}$	mA	JEDEC Standard 78

T11.0 1327

1. This parameter is measured only for initial qualification and after a design or process change that could affect this parameter.

**TABLE 12: AC Operating Characteristics**

Symbol	Parameter	25 MHz		66 MHz		80 MHz		Units
		Min	Max	Min	Max	Min	Max	
$F_{CLK}^1$	Serial Clock Frequency		25		66		80	MHz
$T_{SCKH}$	Serial Clock High Time	18		6.5		6		ns
$T_{SCKL}$	Serial Clock Low Time	18		6.5		6		ns
$T_{SCKR}^2$	Serial Clock Rise Time (Slew Rate)	0.1		0.1		0.1		V/ns
$T_{SCKF}$	Serial Clock Fall Time (Slew Rate)	0.1		0.1		0.1		V/ns
$T_{CES}^3$	CE# Active Setup Time	10		5		5		ns
$T_{CEH}^3$	CE# Active Hold Time	10		5		5		ns
$T_{CHS}^3$	CE# Not Active Setup Time	10		5		5		ns
$T_{CHH}^3$	CE# Not Active Hold Time	10		5		5		ns
$T_{CPH}$	CE# High Time	100		50		50		ns
$T_{CHZ}$	CE# High to High-Z Output		15		7		7	ns
$T_{CLZ}$	SCK Low to Low-Z Output	0		0		0		ns
$T_{DS}$	Data In Setup Time	5		2		2		ns
$T_{DH}$	Data In Hold Time	5		4		4		ns
$T_{HLS}$	HOLD# Low Setup Time	10		5		5		ns
$T_{HHS}$	HOLD# High Setup Time	10		5		5		ns
$T_{HLH}$	HOLD# Low Hold Time	10		5		5		ns
$T_{HHH}$	HOLD# High Hold Time	10		5		5		ns
$T_{HZ}$	HOLD# Low to High-Z Output		20		7		7	ns
$T_{LZ}$	HOLD# High to Low-Z Output		15		7		7	ns
$T_{OH}$	Output Hold from SCK Change	0		0		0		ns
$T_V$	Output Valid from SCK		15		6		6	ns
$T_{SE}$	Sector-Erase		25		25		25	ms
$T_{BE}$	Block-Erase		25		25		25	ms
$T_{SCE}$	Chip-Erase		50		50		50	ms
$T_{BP}^4$	Byte-Program		10		10		10	$\mu\text{s}$

T12.0 1327

1. Maximum clock frequency for Read Instruction, 03H, is 25 MHz
2. Maximum Rise and Fall time may be limited by  $T_{SCKH}$  and  $T_{SCKL}$  requirements
3. Relative to SCK.
4. TBP of AAI-Word Programming is also 10  $\mu\text{s}$  maximum time.

Data Sheet

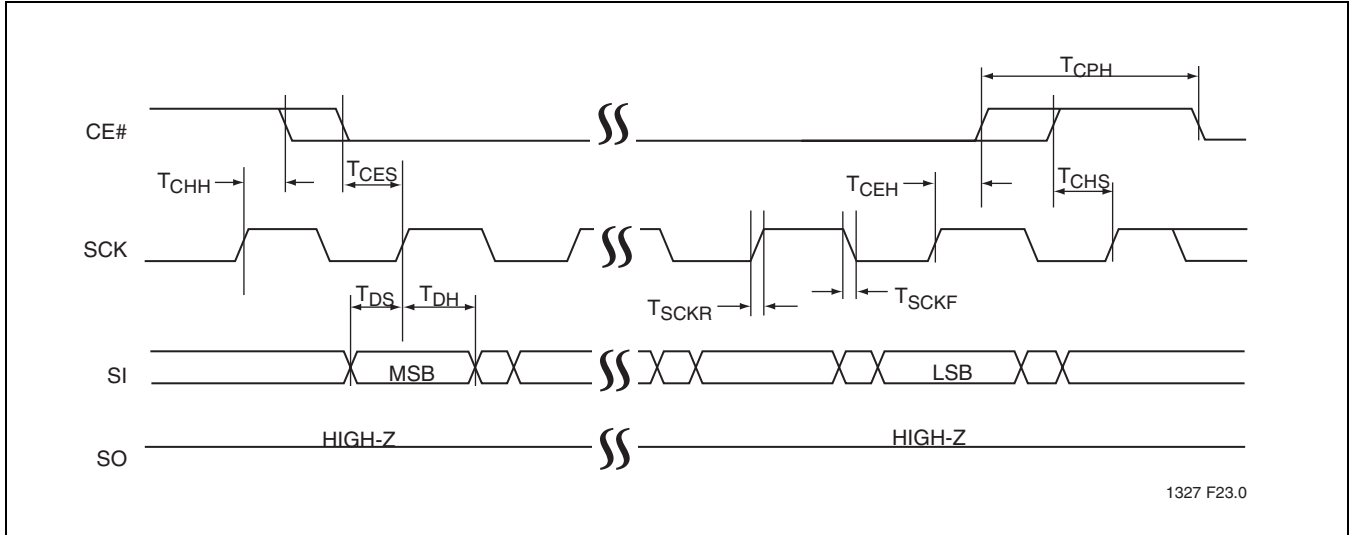


FIGURE 22: Serial Input Timing Diagram

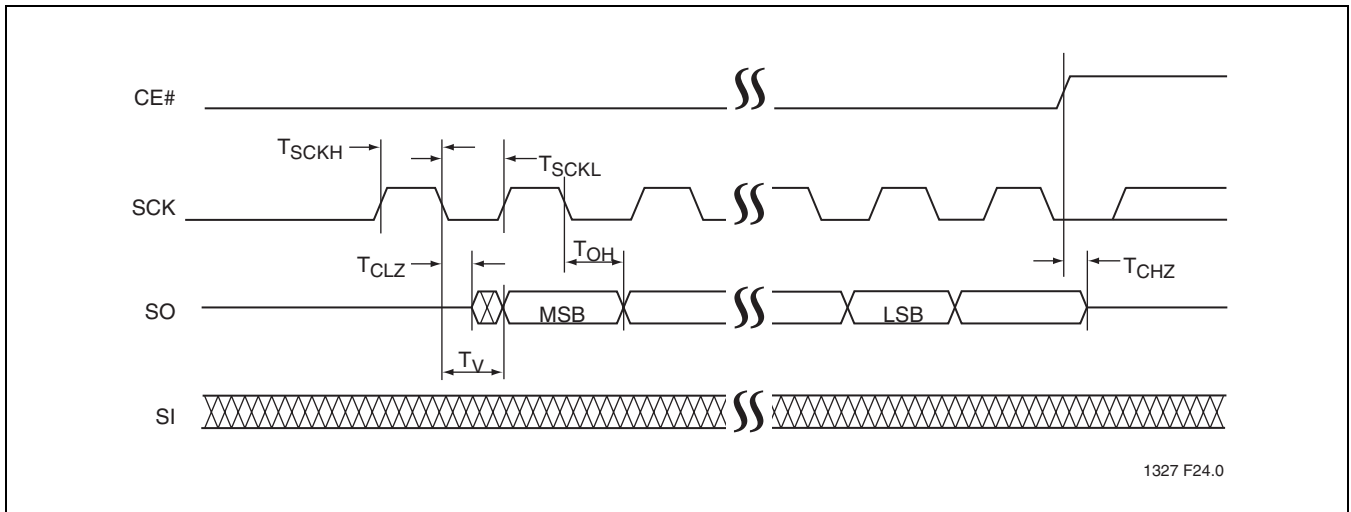


FIGURE 23: Serial Output Timing Diagram

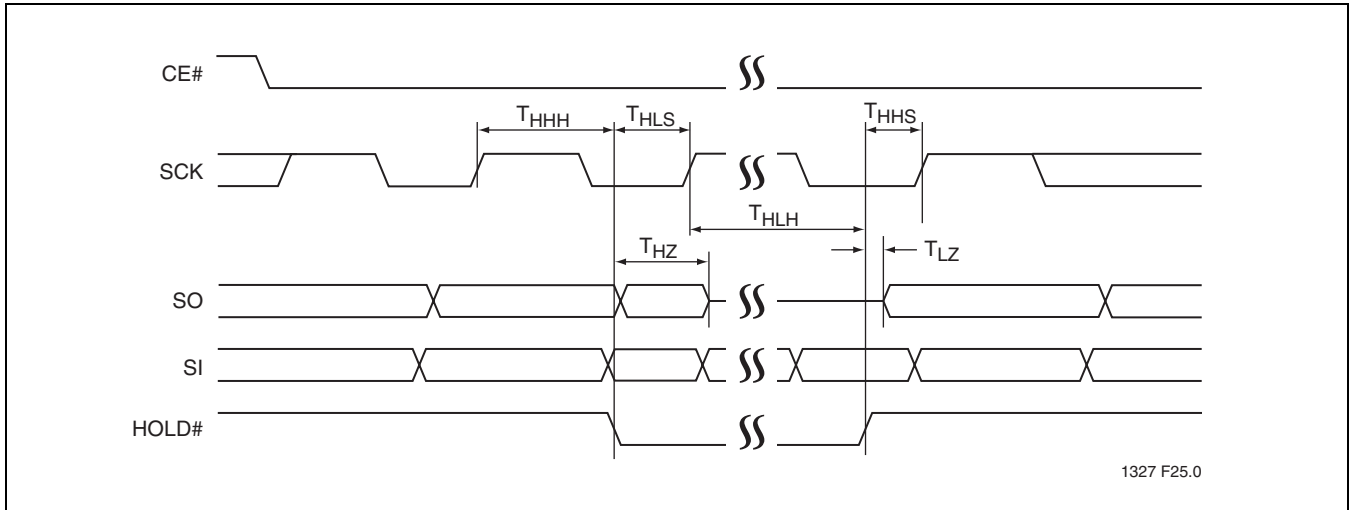


FIGURE 24: Hold Timing Diagram

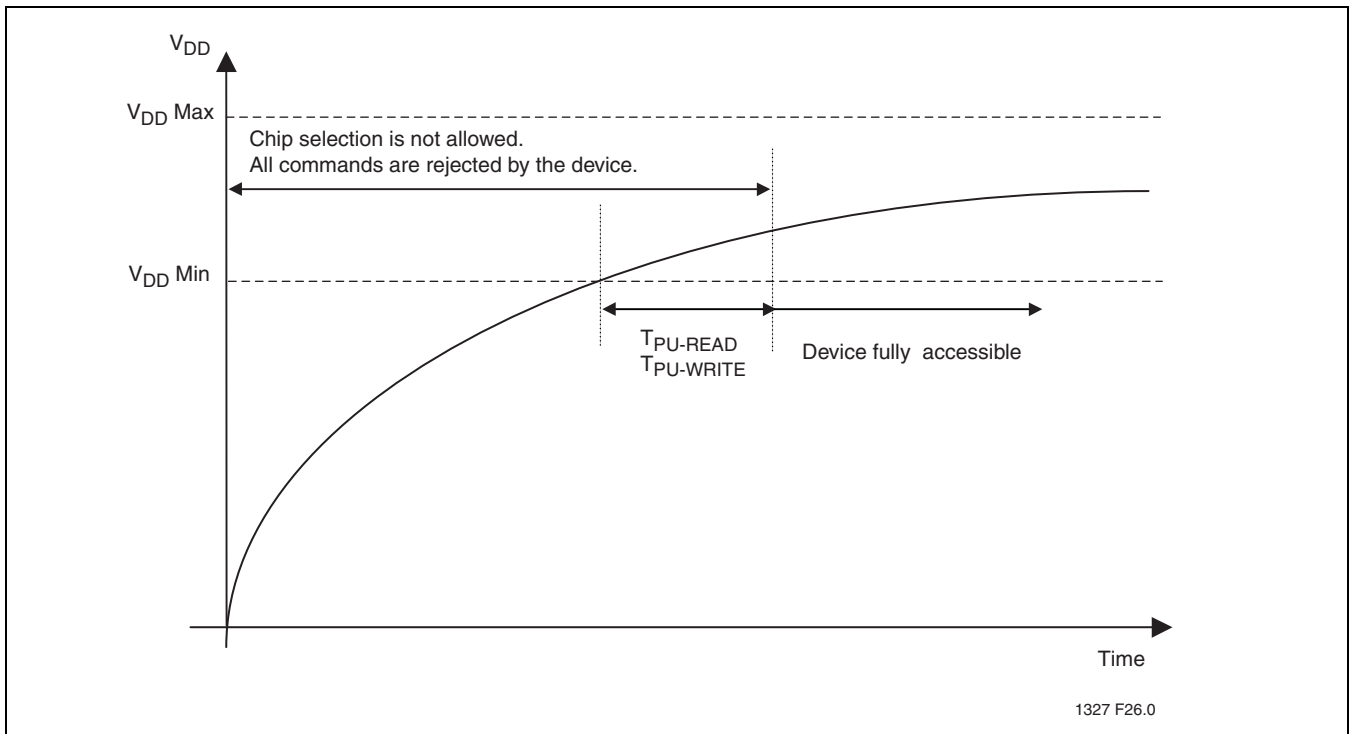


FIGURE 25: Power-up Timing Diagram

Data Sheet

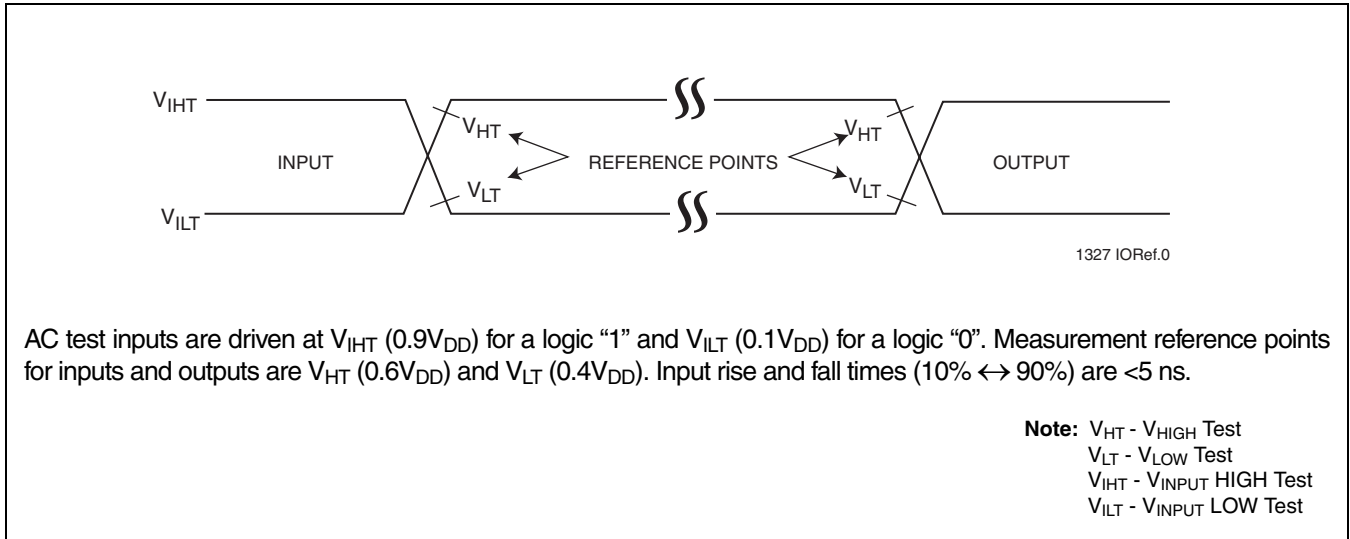
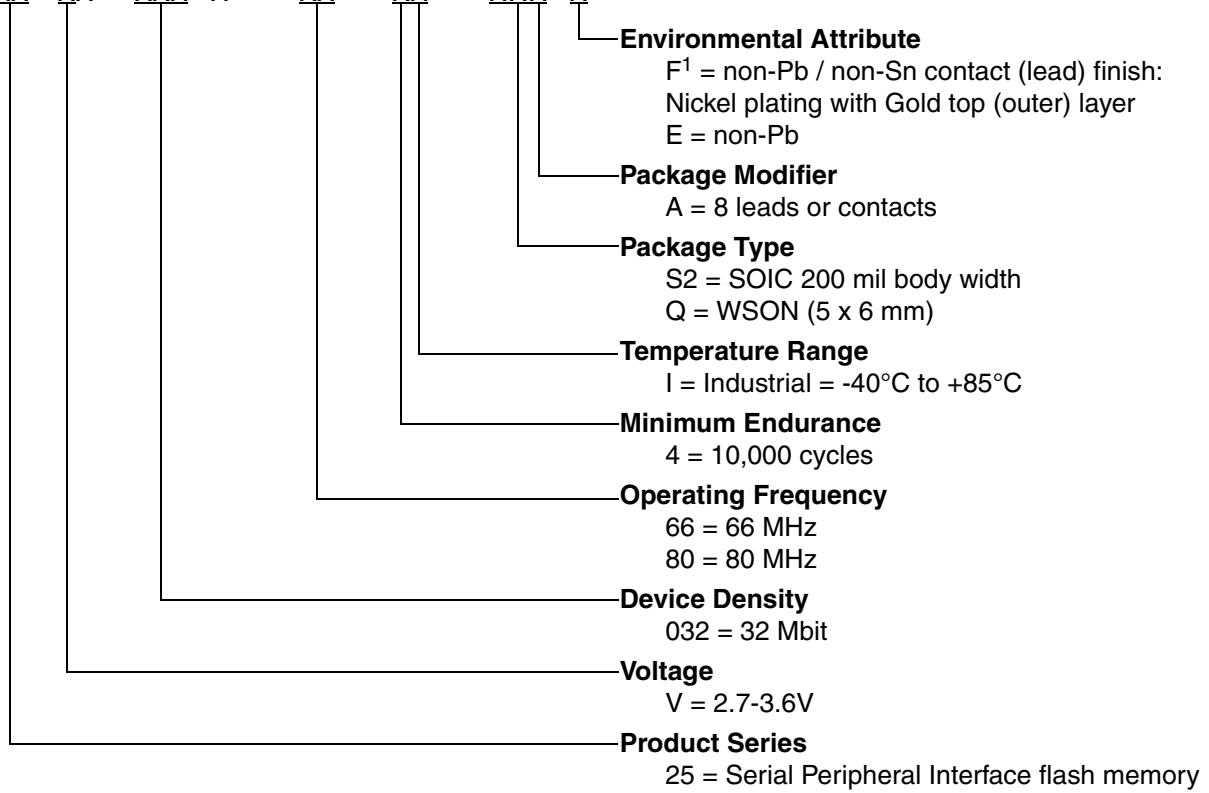


FIGURE 26: AC Input/Output Reference Waveforms



**PRODUCT ORDERING INFORMATION**

D7 T <sup>XX</sup> &5 <sup>XX</sup> JF <sup>XXX</sup> \$32 <sup>X</sup> 6 - <sup>XX</sup> \*6 - <sup>XX</sup> 4I - <sup>XXX</sup> S2A F



1. Environmental suffix "F" denotes non-Pb/non-Sn solder; "E" denotes non-Pb solder. PCT non-Pb/non-Sn solder devices are "RoHS Compliant".

**Valid combinations for PCT25VF032B**

- PCT25VF032B-66-4I-S2AF
- PCT25VF032B-80-4I-S2AF
- PCT25VF032B-80-4I-QAE

**Note:** Valid combinations are those products in mass production or will be in mass production. Consult your PCT sales representative to confirm availability of valid combinations and to determine availability of new combinations.

Data Sheet

PACKAGING DIAGRAMS

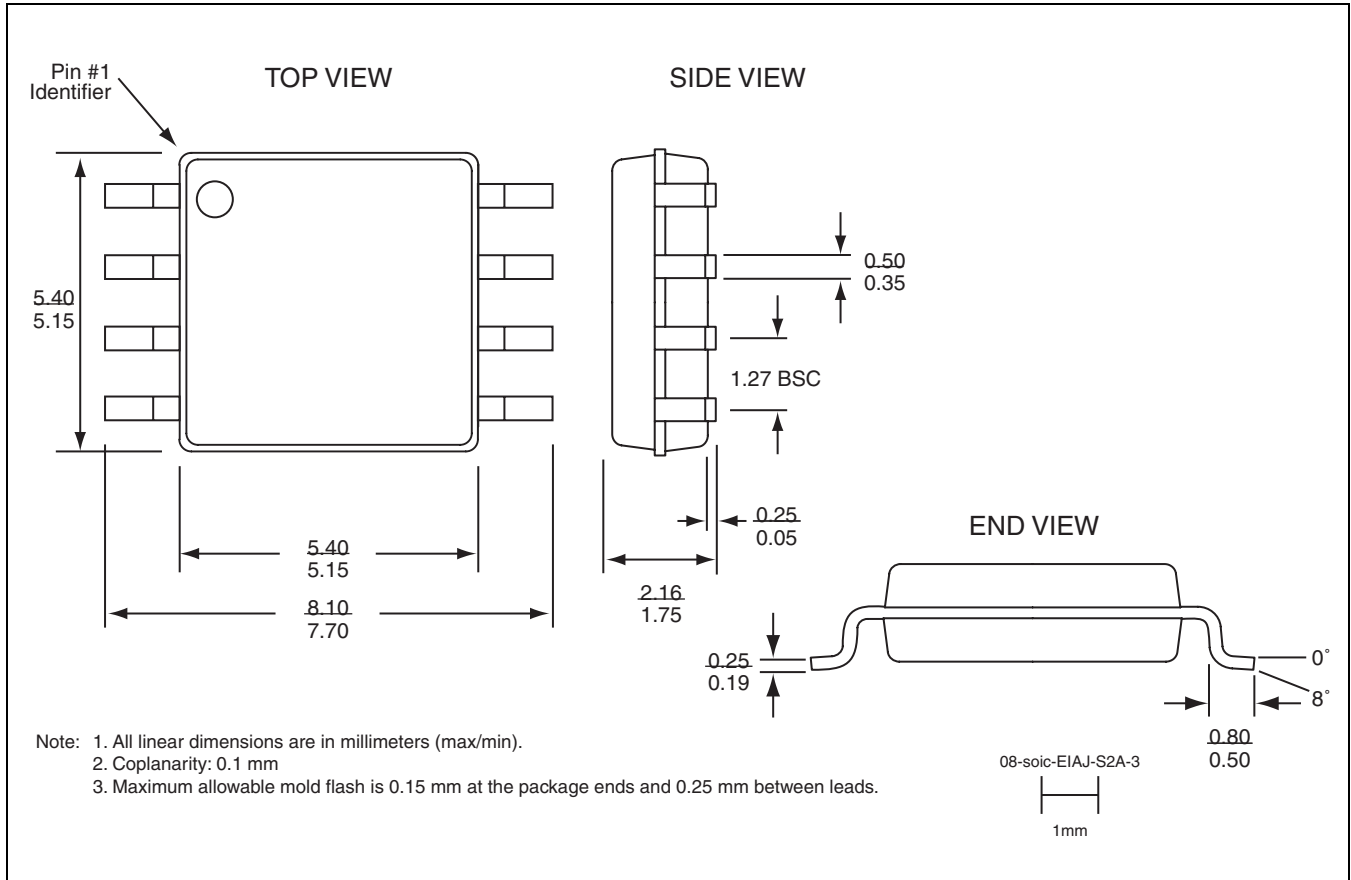
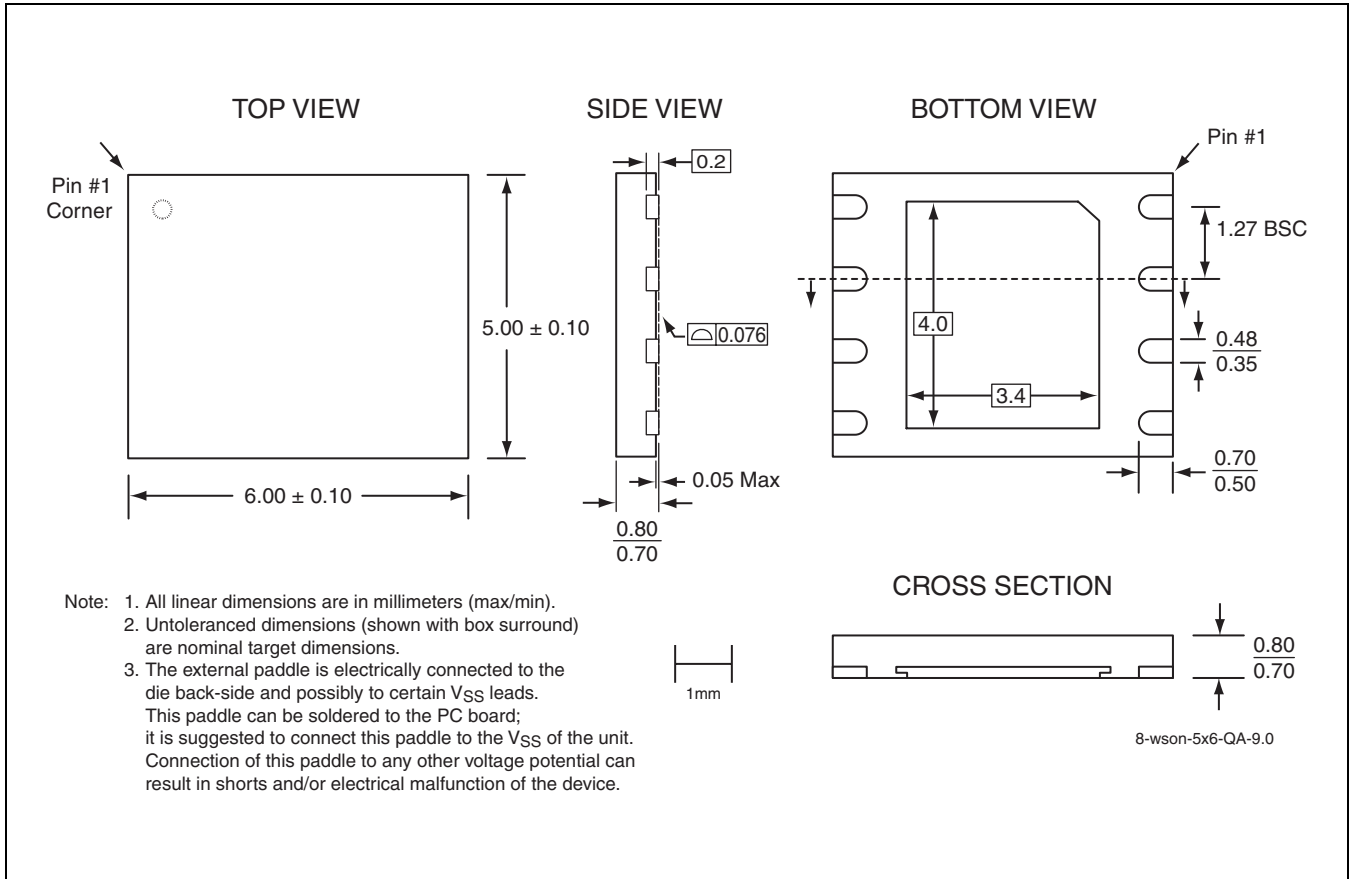


FIGURE 27: 8-lead Small-outline Integrated Circuit (SOIC) 200 mil body width (5.2mm x 8mm)  
PCT Package Code: S2A



**FIGURE 28: 8-Contact Very-very-thin, Small-outline, No-lead (WSON)**  
**PCT Package Code: QA**

Data Sheet

**TABLE 13: Revision History**

Number	Description	Date
00	<ul style="list-style-type: none"> <li>• Initial release of data sheet</li> </ul>	Oct 2006
01	<ul style="list-style-type: none"> <li>• Changed clock frequency from 50 MHz to 66 MHz globally</li> <li>• Revised Table 12 AC Operating Characteristics</li> <li>• Revised Product Ordering Information and Valid Combinations on page 25</li> <li>• Revised Figure 10 and Figure 11</li> <li>• Changed IDDR2 from Max 15 mA to Max 20 mA in Table 8</li> <li>• Changed TDH from Min 5 ns to Min 4 ns (66MHz) in Table 12</li> </ul>	Mar 2008
02	<ul style="list-style-type: none"> <li>• Removed SC package</li> <li>• Removed Commercial Temperature.</li> </ul>	Jul 2008
03	<ul style="list-style-type: none"> <li>• Added new valid combination with 80 MHz Clock Frequency</li> <li>• Added QA package</li> <li>• Edited Features, page 1</li> <li>• Edited Product Description, page 1</li> <li>• Edited Table 5 on page 8</li> <li>• Edited Figure 6 on page 9</li> <li>• Edited Table 8 on page 20</li> <li>• Edited Table 12 on page 21</li> </ul>	May 2009