

Version: 2.0

TECHNICAL SPECIFICATION
MODEL NO: PD035QX1

The content of this information is subject to be changed without notice.
Please contact PVI or its agent for further information.

Customer's Confirmation

Customer _____

Date _____

By _____

PVI's Confirmation

Confirmed By _____

Prepared By _____

Revision History

Rev.	Eng.	Issued Date	Revised Contents
0.1	Sarah Huang	Sep 11, 2007	Preliminary
0.2	Sarah Huang	Nov 19, 2007	Modify Page 6 5.Input / Output Terminals: Pin1~4 Symbol Add Page 14 12. Optical Characteristics
0.3	Sarah Huang	Feb 1, 2008	Add Page 14 10-5) Display on Flow
1.0	Sarah Huang	Feb 21, 2008	Modify Page 8 7-2) Recommended Driving Condition for Back Light ILED from 15mA to 20mA Modify Page 6 5-1) TFT-LCD Panel Driving pin
2.0	Sarah Huang	Apr 15, 2008	Add Page 16 12. Optical Characteristics Color Chromaticity

**TECHNICAL SPECIFICATION
CONTENTS**

<i>NO.</i>	<i>ITEM</i>	<i>PAGE</i>
-	Cover	1
-	Revision History	2
-	Contents	3
1	Application	4
2	Features	4
3	Mechanical Specifications	4
4	Mechanical Drawing of TFT-LCD module	5
5	Input / Output Terminals	6
6	Absolute Maximum Ratings	7
7	Electrical Characteristics	7
8	Pixel Arrangement	9
9	Block Diagram	10
10	AC Characteristics	11
11	Power On Sequence	16
12	Optical Characteristics	16
13	Handling Cautions	19
14	Reliability Test	20
15	Packing Diagram	21

1. Application

This technical specification applies to 3.5" color TFT-LCD module; PD035QX1. The module applies to videophone, door phone and other electronic products, which require high quality flat panel displays.

If you must use in high reliability environment can't over reliability test condition.

2. Features

- . Amorphous silicon TFT LCD panel with LED backlight unit
- . Pixel in stripe configuration
- . Thin and lightweight
- . Display Colors : 262K colors
- . Optimum Viewing Direction : 6 o'clock
- . Support Interface: 18-bit MCU interface/ 18-bit RGB interface/ 4pin or 3pin serial interface

3. Mechanical Specifications

Parameter	Specifications	Unit
Screen Size	3.5(diagonal)	inch
Display Format	240 ×R, G, B) ×20	dot
Display Colors	262K	
Active Area	53.64 (H) ×1.52 (V)	mm
Pixel Pitch	0.2235(H) ×0.2235(V)	mm
Pixel Configuration	Stripe	
Outline Dimension	64.0(W) ×85.0 (H) ×3.5 (typ.) (D)	mm
Weight	38.8±4	g
Back-light	9-LEDs	
Surface treatment	Anti-glare + EWV	
Display mode	Normally white	
Gray scale inversion direction	6 o'clock [Note 12-1]	

4. Mechanical Drawing of TFT-LCD Module

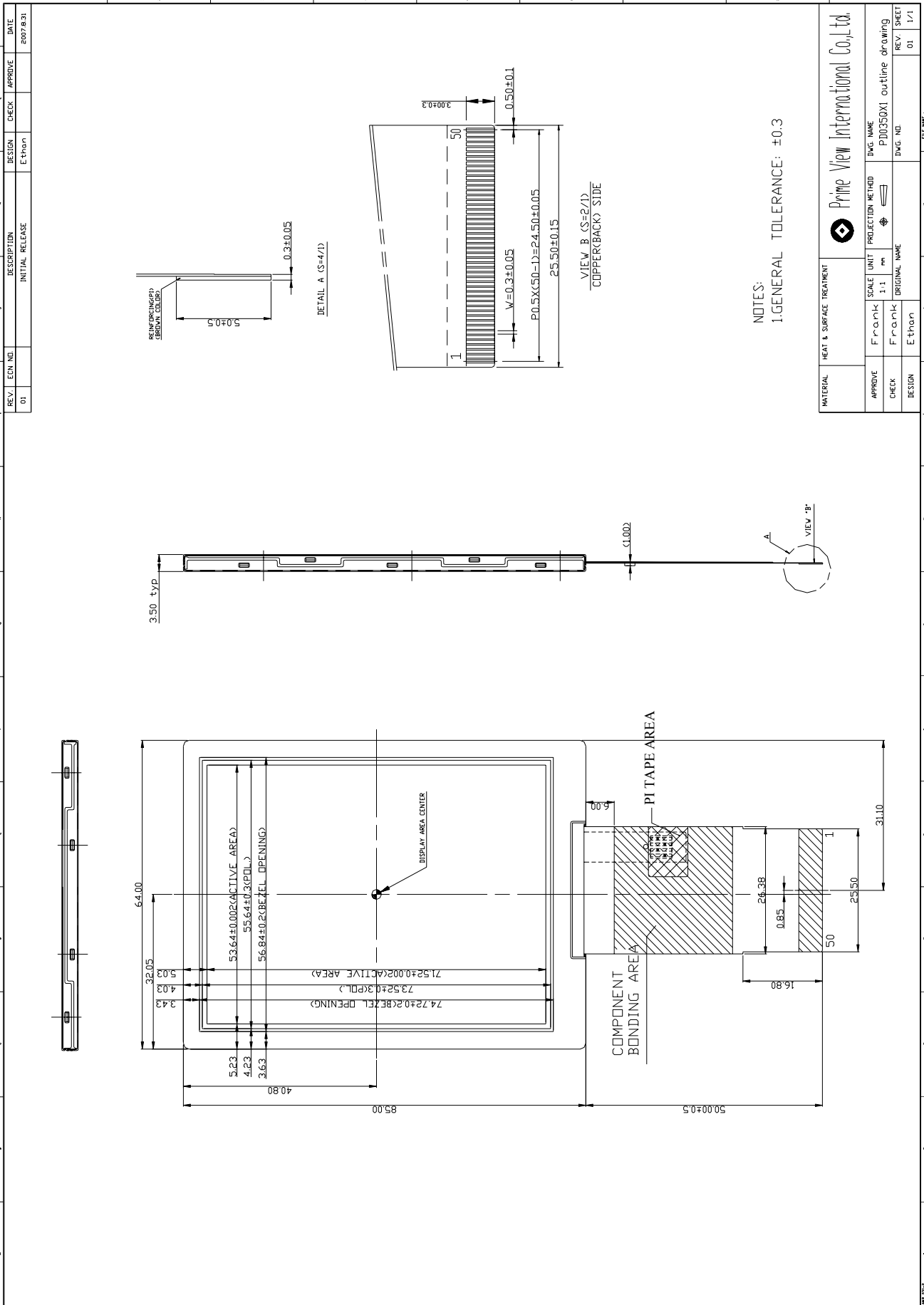

NOTES:
1. GENERAL TOLERANCE: ±0.3

MATERIAL		HEAT & SURFACE TREATMENT		Prime View International Co., Ltd.		
APPROVE	SCALE	UNIT	PROJECTION METHOD	DWG. NAME	REV. SHEET	
CHECK	1:1	mm	1st Angle	PD035QX1 outline drawing		REV. 01
DESIGN	Frank	Frank	Frank	DWG. NO.		01 / 1/1
	Ethan	Ethan	Ethan	ORIGINAL NAME		

5. Input / Output Terminals
5-1) TFT-LCD Panel Driving

Pin No.	Symbol	Function	Remark
1	VLED	Supply voltage for LED Backlight	
2	GLED1	Cathode of LED Backlight	
3	GLED2	Cathode of LED Backlight	
4	GLED3	Cathode of LED Backlight	
5	MTP_PWR	MTP programming power Pin	Note 5-1
6	IM0	MCU Interface Select Pin	Note 5-2
7	IM2	MCU Interface Select Pin	
8	P68	MCU Interface mode select Pin	
9	IM1	MCU Interface Select Pin	
10	RESET	Reset Input Pin	
11	VS	Vertical sync. Single in RGB I/F	
12	HS	Horizontal sync. Single in RGB I/F	
13	PCLK	Pixel clock single in RGB I/F	
14	ENABLE	Data enable single in RGB I/F	
15	D17	MCU Parallel / RGB Interface Data Bus	
16	D16	MCU Parallel / RGB Interface Data Bus	
17	D15	MCU Parallel / RGB Interface Data Bus	
18	D14	MCU Parallel / RGB Interface Data Bus	
19	D13	MCU Parallel / RGB Interface Data Bus	
20	D12	MCU Parallel / RGB Interface Data Bus	
21	D11	MCU Parallel / RGB Interface Data Bus	
22	D10	MCU Parallel / RGB Interface Data Bus	
23	D9	MCU Parallel / RGB Interface Data Bus	
24	D8	MCU Parallel / RGB Interface Data Bus	
25	D7	MCU Parallel / RGB Interface Data Bus	
26	D6	MCU Parallel / RGB Interface Data Bus	
27	D5	MCU Parallel / RGB Interface Data Bus	
28	D4	MCU Parallel / RGB Interface Data Bus	
29	D3	MCU Parallel / RGB Interface Data Bus	
30	D2	MCU Parallel / RGB Interface Data Bus	
31	D1	MCU Parallel / RGB Interface Data Bus	
32	D0	MCU Parallel / RGB Interface Data Bus	
33	SDA	Serial Input/Output Pin	
34	RDX(E)	Read enable in 8080-parallel I/P ; Read write operation enable pin in 6800-parallel I/P	
35	WRX(R/WX)(D/CX)	Write enable in 8080-parallel I/P ; Read write selection in 6800-parallel I/P ; In serial I/F for 4-line serial I/F	
36	D/CX(SCL)	Display data/Command Select pin or Serial interface clock	
37	CS	Chip Select Pin	
38	4WSPI	Serial interface select Pin	
39	VCI	Power Supply for Logic and Booster	Note 5-3
40	VCI	Power Supply for Logic and Booster	
41	RCM0	RGB or MCU Interface mode selection pin	Note 5-4
42	RCM1	RGB or MCU Interface mode selection pin	
43	GND	Ground	
44	GND	Ground	
45	GND	Ground	
46	GND	Ground	
47	GND	Ground	
48	GND	Ground	
49	GND	Ground	
50	GND	Ground	

Note 5-1: MTP programming power pin.
 Normal Operation: Keep the pin floating
 MTP programming: Apply external power 7.0V to this pin

Note 5-2:

P68	IM2	IM1	IM0	Interface	RDX	WRX	D/CX	Read back selection
X	0	X	X	Serial interface	Note 1	Note 1	SCL	D[17:0]: Unused, Din+Dout: SDA
0	1	1	0	8080 MCU 18-bit Parallel	RDX	WRX	D/CX	D[17:0]: 18-bit Data

Note 5-3: VCI=3.3V

Note 5-4:

RCM1	RCM0	RGB or MCU Interface mode selection pin
0	0	MCU I/F
1	0	RGB I/F

6. Absolute Maximum Ratings:

The followings are maximum values, which if exceeded, may cause faulty operation or damage to the unit.

Item	Symbol	Value	Unit
Supply voltage (Logic)	VCI	-0.3 ~ +4.6	V
Supply voltage (Analog)	VDD	-0.3 ~ +4.6	V
Supply voltage (Digital)	VCC	-0.3 ~ +3.0	V
Driver supply voltage	VGH-VGL	-0.3 ~ +33.0	V
Logic Input voltage range	VIN	-0.3 ~ VCI +0.3	V
Logic Output voltage range	VO	-0.3 ~ VCI +0.3	V

7. Electrical Characteristics

7-1) Recommended Operating Conditions:

Item	Symbol	Min.	Typ.	Max.	Unit	Remark
Supply voltage (Logic)	VCI	-	3.2	-	V	
Logic Input voltage range	VIN	3.1	-	3.3	V	
Logic Output voltage range	VO	0.8	-	VCI	V	
TFT Common Electrode Voltage	VCOMH	-	5.02	-	V	Note 7-1
	VCOML	-	-1.02	-	V	
Black of Video Low Voltage	VLB	-	0.6	-	V	Note 7-2
Black of Video High Voltage	VHB	-	5.1	-	V	
White of Video Low Voltage	VLW	-	0.78	-	V	
White of Video High Voltage	VHW	-	4.98	-	V	
Gate Driver High voltage	VGH	-	14.67	-	V	
Gate Driver Low voltage	VGL	-	-6.93	-	V	

Note7-1 : VCOM must be adjusted optimize display quality, crosstalk, contrast ration and etc.

Note7-2 :



7-2) Recommended Driving Condition for Back Light

Ta = 25°C

Parameter	Symbol	Min	TYP	MAX	Unit	Remark
Supply voltage of LED backlight	V _{LED-1~3}	-	-	(10.5)	V	Note 7-3
Supply current of LED backlight	I _{LED-1~3}	-	20	-	mA	Note 7-4
Backlight Power Consumption	P _{LED}	-	-	630	mW	Note 7-3/7-5

Note 7-3: I_{LED}= 20mA,constant current

Note 7-4: The LED driving condition is defined for each LED module. (3 LED Serial)
 Input current = 20mA * 3 = 60mA

Note 7-5: P_{LED} = V_{LED-1} * I_{LED-1} + V_{LED-2} * I_{LED-2} + V_{LED-3} * I_{LED-3}

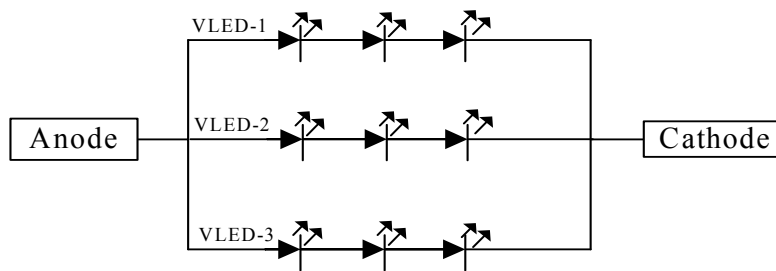

7-3) Power Consumption

Parameter	Symbol	Condition	Typ.	Max.	Unit	Remark
Supply current for source driver and gate driver	I _{CI}	V _{CI} = 3.2 V	9.3	23.25	mA	
Back Light Power Consumption			-	630	mW	Note 7-3
Total Power Consumption			-	704.4	mW	Note 7-6

Note 7-6: Back light power consumption is calculated by I_L * V_L.

8. Pixel Arrangement

The LCD module pixel arrangement is the stripe.

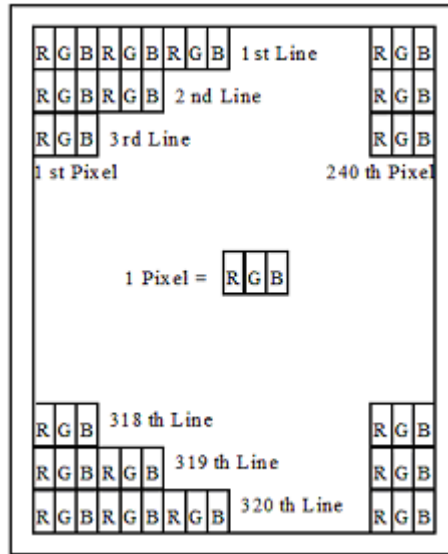

9. Block Diagram

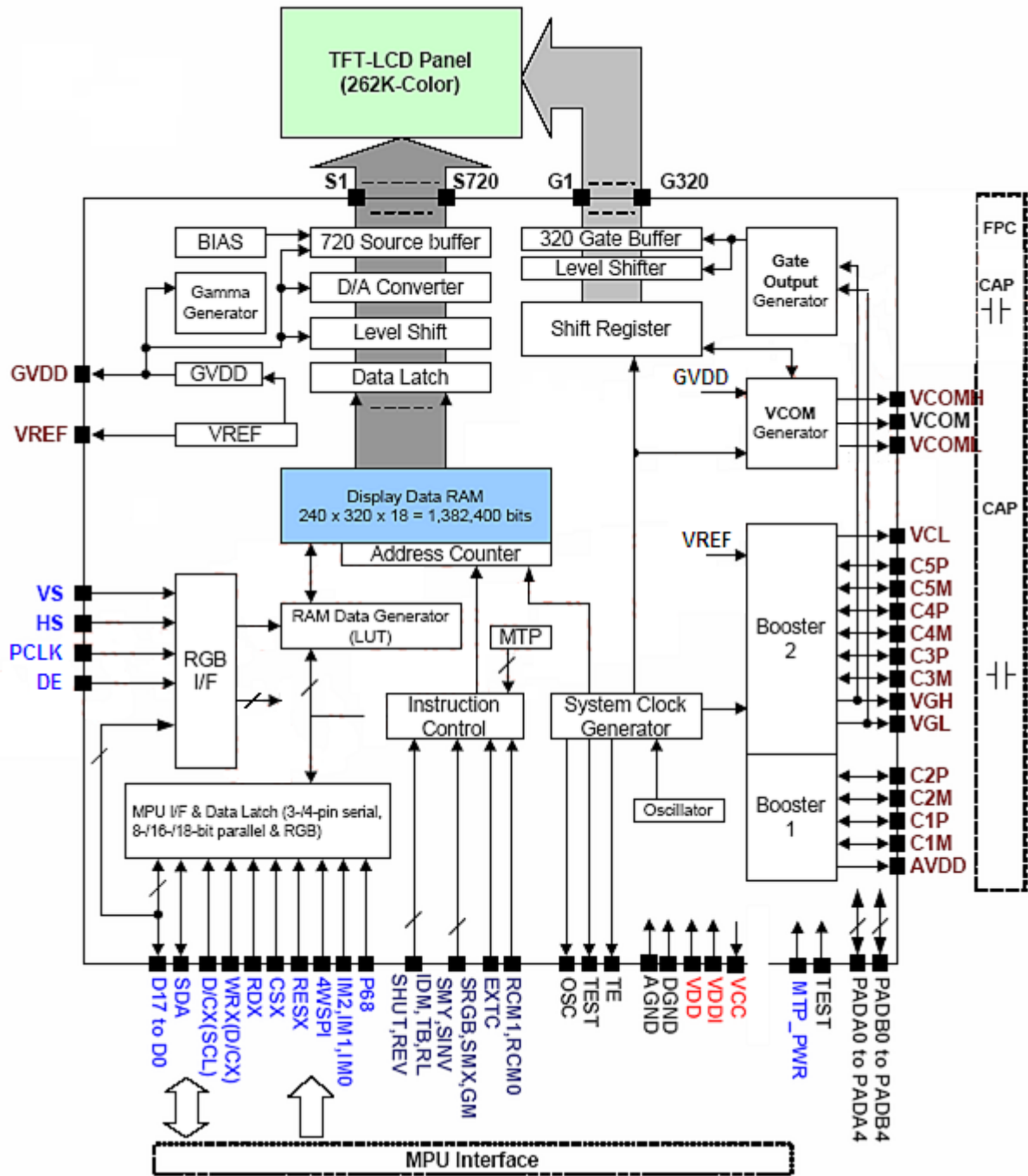

10. AC Characteristics

10-1) RGB Interface Characteristics

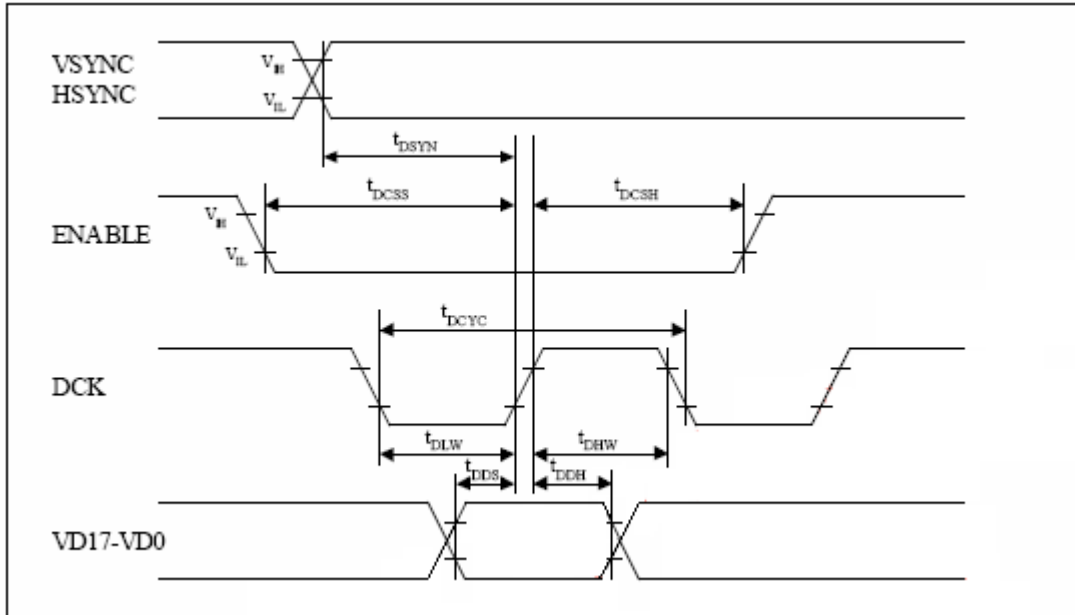

AGND=CGND=VGS=DGND=0V, VDDI=1.65~ 3.3V, VDD=2.5~ 3.3V, Ta=-30~70°C

Symbol	Parameter	Conditions	Related Pins	MIN	TYP	MAX	Unit
t_{DCYC}	PCLK cycle time	-	PCLK	60	-	226	ns
t_{DLW}	PCLK Low time	-	PCLK	15	-	-	ns
t_{CHW}	PCLK High time	-	PCLK	15	-	-	ns
t_{DDS}	RGB Data setup time	-	D17-D0	15	-	-	ns
t_{DDH}	RGB Data hold time	-	D17-D0	15	-	-	ns
t_{DCSS}	DE setup time	-	DE	15	-	-	ns
t_{DCSH}	DE hold Time	-	DE	15	-	-	ns
t_{DSYN}	SYNC setup time	-	HSYNC, VSYNC	15	-	-	ns

10-2) Vertical and Horizontal timing for RGB I/F

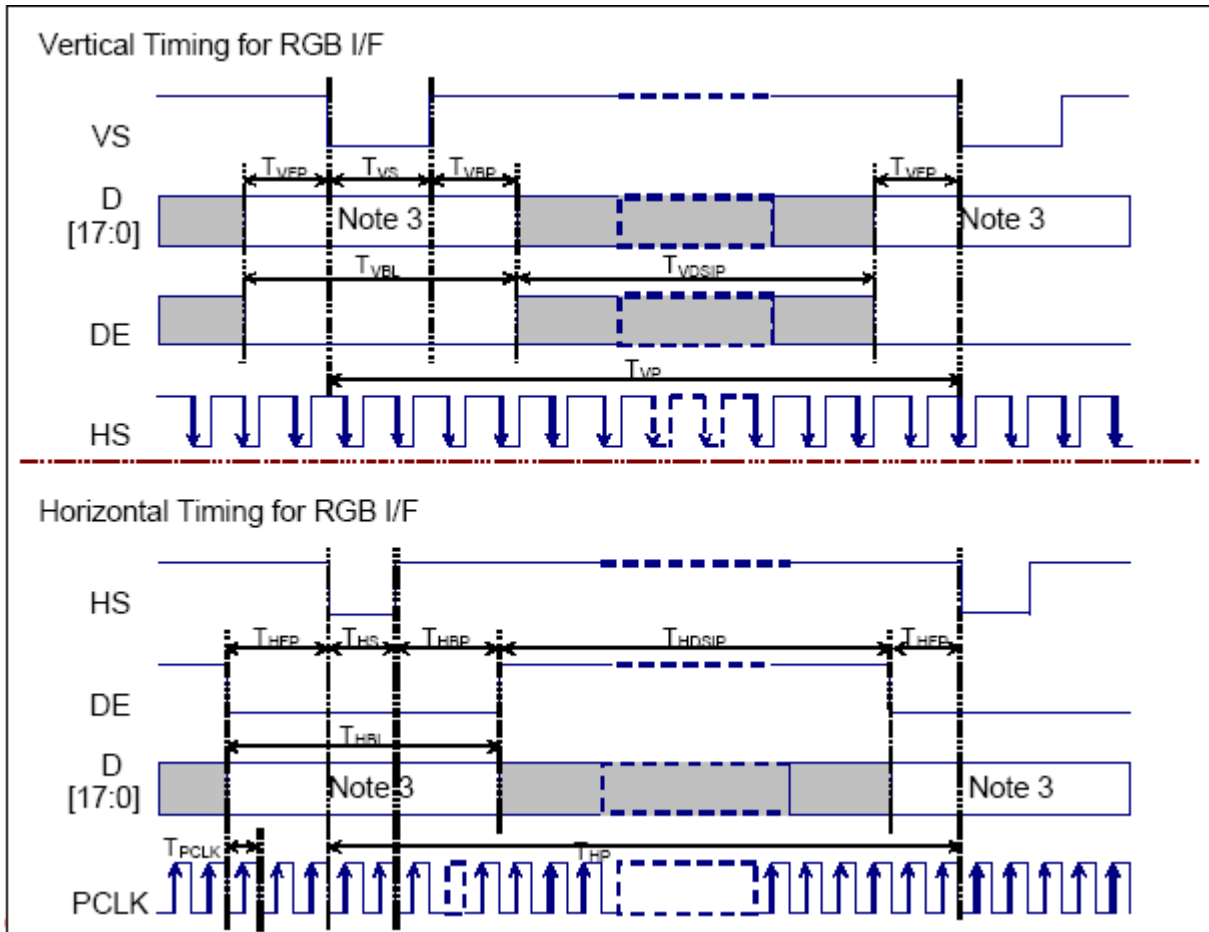

Item	Symbol	Condition	Specification			Unit
			Min	Type.	Max	
Vertical Timing						
Vertical cycle period	T_{VP}		326		330	HS
Vertical low pulse width	T_{VS}		2		4	HS
Vertical front porch	T_{VFP}		2		4	HS
Vertical back porch	T_{VBP}		2		4	HS
Vertical data start line		$T_{VS} + T_{VBP}$	4		8	HS
Vertical blanking period	T_{VBL}	$T_{VS} + T_{VBP} + T_{VFP}$	6		10	HS
Vertical active area	T_{VDISP}			320		HS
Vertical refresh rate	TVRR	Frame rate	61.75	65	68.25	Hz
Horizontal Timing						
Horizontal cycle period	T_{HP}		272		512	PCLK
Horizontal low pulse width	T_{HS}		2		256	PCLK
Horizontal front porch	T_{HFP}		2		256	PCLK
Horizontal back porch	T_{HBP}		2		256	PCLK
Horizontal data start point		$T_{HS} + T_{HBP}$	30		256	PCLK
		$f_{HS} + f_{HBP}$	1.0			μs
Horizontal blanking period	T_{HBL}	$T_{HS} + T_{HBP} + T_{HFP}$	32		256	PCLK
Horizontal active area	T_{HDISP}			240		PCLK
Pixel clock cycle	$T_{PCLKCYC}$		66.7		174	ns
When TVRR=65Hz	$f_{PCLKCYC}$		5.8		15.0	MHz

Note 1. VDDI=1.65 to 3.3V, VDD=2.5 to 3.3V, AGND=DGND=0V, Ta=-30 to 70°C (to +85°C no damage)

Note 2. Data lines can be set to "High" or "Low" during blanking time – Don't care.

Note 3. HP is multiples of eight PCLK.

10-3) Parallel Interface Characteristics (80-series MPU)

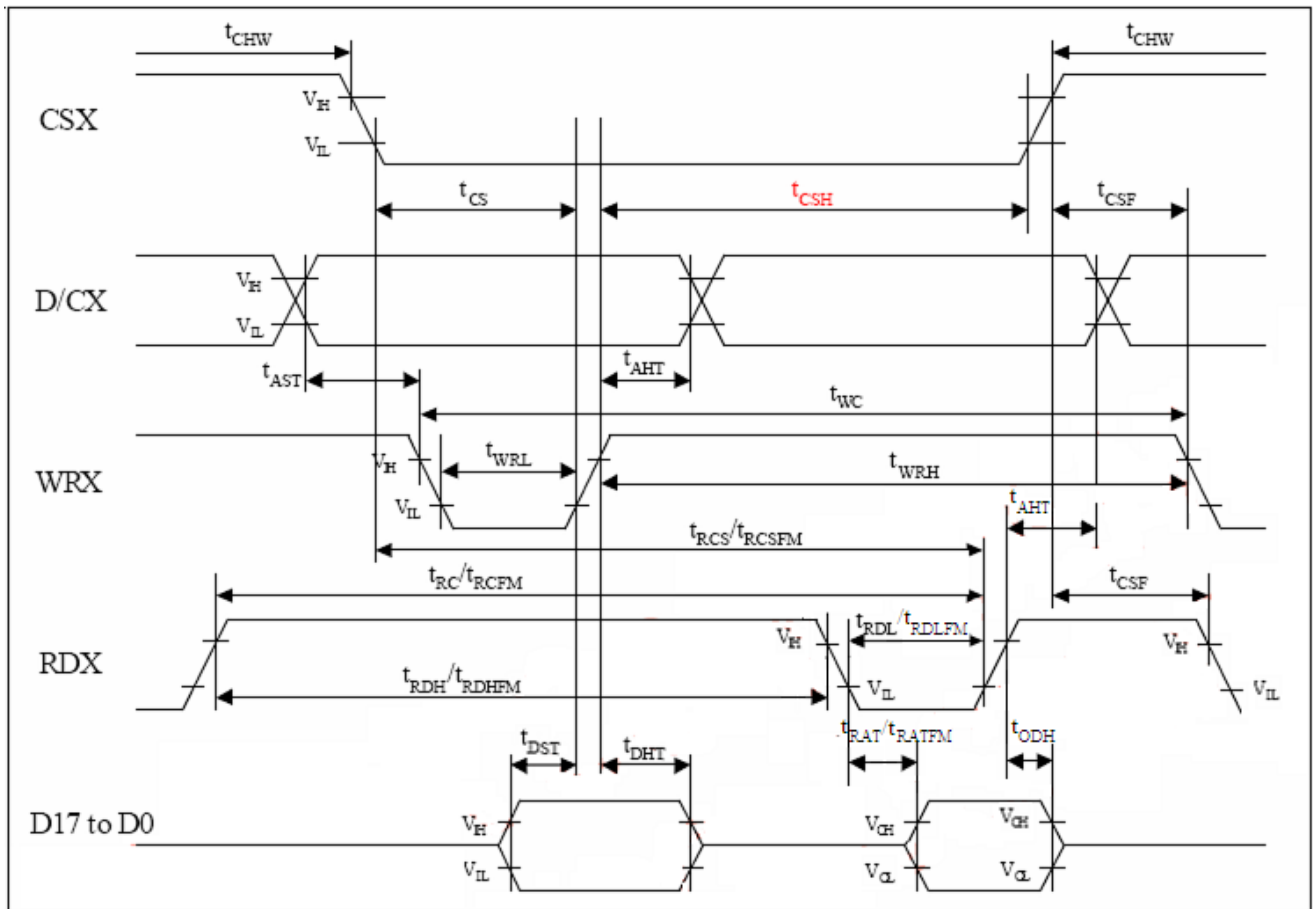

Parallel Interface 18,16,9,8-bits bus (80-series MCU)

Signal	Symbol	Parameter	MIN	MAX	Unit	Description
D/CX	t _{AST}	Address setup time	10		ns	-
	t _{AHT}	Address hold time (Write/Read)	10		ns	
CSX	t _{CHW}	Chip select "H" pulse width	0		ns	-(3-transfer for one pixel)
	t _{CS}	Chip select setup time (Write)	20		ns	
	t _{RCS}	Chip select setup time (Read ID)	35		ns	
	t _{RCSFM}	Chip select setup time (Read FM)	320		ns	
	t _{CSF}	Chip select wait time (Write/Read)	10		ns	
	t _{CSH}	Chip select hold time	10		ns	
WRX	t _{WC}	Write cycle	65		ns	
	t _{WRH}	Control pulse "H" duration	20		ns	
	t _{WRL}	Control pulse "L" duration	20		ns	
RDX (ID)	t _{RC}	Read cycle (ID)	160		ns	When read ID data
	t _{RDH}	Control pulse "H" duration (ID)	90		ns	
	t _{RDL}	Control pulse "L" duration (ID)	45		ns	
RDX (FM)	t _{RCFM}	Read cycle (FM)	450		ns	When read from frame memory
	t _{RDHFM}	Control pulse "H" duration (FM)	90		ns	
	t _{RDLFM}	Control pulse "L" duration (FM)	355		ns	
D[17:0]	t _{DST}	Data setup time	10		ns	For maximum C _L =30pF For minimum C _L =8pF
	t _{DHT}	Data hold time	10		ns	
	t _{RAT}	Read access time (ID)		40	ns	
	t _{RATFM}	Read access time (FM)		340	ns	
	t _{ODH}	Output disable time	20	80	ns	

Note 1: VDD1=1.65 to 3.3V, VDD=2.5 to 3.3V, AGND=CGND=VGS=DGND=0V, Ta=-30 to 70 °C (to +85 °C no damage)

10-4) Interfacing with 80-series MPU 18-Bit Bus (P68='0', IM2=0='110')(RCM1='0', RCM0='x')

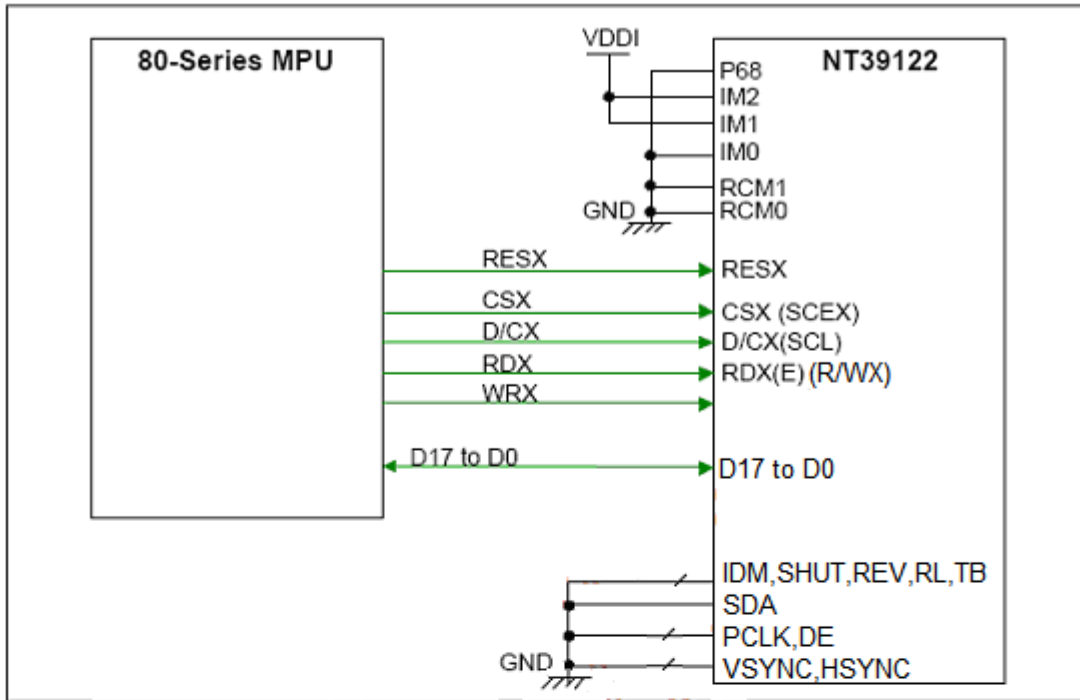

Interfacing with RGB mode 1 (RCM1='1', RCM0='0')

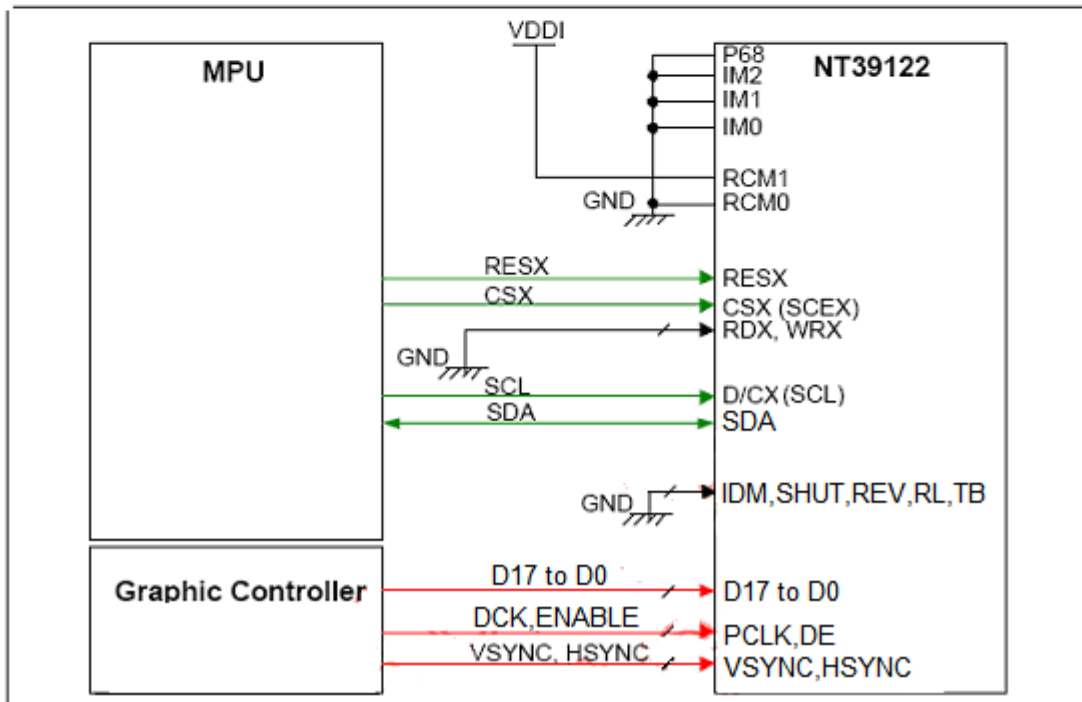

10-5) Display on Flow

```

//Software setting
Init_Data_Comm(0x0001);
DelayX1ms(5);

Init_Data_Comm(0x0011);
DelayX1ms(120);

Init_Data_Comm(0x00FE);
Init_Data_Param(0x0000);

//Power control setting

Init_Data_Comm(0x00C0);
Init_Data_Param(0x0006);

Init_Data_Comm(0x00C1);
Init_Data_Param(0x0005);

Init_Data_Comm(0x00C2);
Init_Data_Param(0x0005);
Init_Data_Param(0x0000);

Init_Data_Comm(0x00C3);
Init_Data_Param(0x0005);
Init_Data_Param(0x0000);

Init_Data_Comm(0x00C4);
Init_Data_Param(0x0005);
Init_Data_Param(0x0000);

Init_Data_Comm(0x00C5);
Init_Data_Param(0x0050);
Init_Data_Param(0x0028);

Init_Data_Comm(0x00C7);
Init_Data_Param(0x00C3);

//Display control setting

Init_Data_Comm(0x00B1);
Init_Data_Param(0x005a);
Init_Data_Param(0x0001);

Init_Data_Comm(0x00B2);
Init_Data_Param(0x006A);
Init_Data_Param(0x0015);

Init_Data_Comm(0x00B3);
Init_Data_Param(0x006A);
Init_Data_Param(0x0015);

Init_Data_Comm(0x00B4);
Init_Data_Param(0x0003);

Init_Data_Comm(0x00B6);
Init_Data_Param(0x0031);
Init_Data_Param(0x0002);

Init_Data_Comm(0x00B5);
Init_Data_Param(0x0001);

Init_Data_Comm(0x0026);
Init_Data_Param(0x0010);

//Gamma control setting

Init_Data_Comm(0x00E0);
Init_Data_Param(0x000f);
Init_Data_Param(0x0077);
Init_Data_Param(0x0045);
Init_Data_Param(0x0070);
Init_Data_Param(0x000a);
Init_Data_Param(0x0002);
Init_Data_Param(0x0083);
Init_Data_Param(0x0000);
Init_Data_Param(0x0007);
Init_Data_Param(0x0000);
Init_Data_Param(0x0000);

Init_Data_Comm(0x00E1);
Init_Data_Param(0x007c);
Init_Data_Param(0x0056);
Init_Data_Param(0x0077);
Init_Data_Param(0x0014);
Init_Data_Param(0x000d);
Init_Data_Param(0x0000);
Init_Data_Param(0x004f);
Init_Data_Param(0x00f7);
Init_Data_Param(0x0000);
Init_Data_Param(0x0006);
Init_Data_Param(0x0000);

Init_Data_Comm(0x00E2);
Init_Data_Param(0x000f);
Init_Data_Param(0x0077);
Init_Data_Param(0x0045);
Init_Data_Param(0x0070);
Init_Data_Param(0x000a);
Init_Data_Param(0x0002);
Init_Data_Param(0x0083);
Init_Data_Param(0x0000);
Init_Data_Param(0x0007);
Init_Data_Param(0x0000);
Init_Data_Param(0x0000);

Init_Data_Comm(0x00E3);
Init_Data_Param(0x007c);
Init_Data_Param(0x0056);
Init_Data_Param(0x0077);
Init_Data_Param(0x0014);
Init_Data_Param(0x000d);
Init_Data_Param(0x0000);
Init_Data_Param(0x004f);
Init_Data_Param(0x00f7);
Init_Data_Param(0x0000);
Init_Data_Param(0x0006);
Init_Data_Param(0x0000);

Init_Data_Comm(0x00E4);
Init_Data_Param(0x000f);
Init_Data_Param(0x0077);
Init_Data_Param(0x0045);
Init_Data_Param(0x0070);
Init_Data_Param(0x000a);
Init_Data_Param(0x0002);
Init_Data_Param(0x0083);
Init_Data_Param(0x0000);
Init_Data_Param(0x0007);
Init_Data_Param(0x0000);
Init_Data_Param(0x0000);

Init_Data_Comm(0x00E5);
Init_Data_Param(0x007c);
Init_Data_Param(0x0056);
Init_Data_Param(0x0077);
Init_Data_Param(0x0014);
Init_Data_Param(0x000d);
Init_Data_Param(0x0000);
Init_Data_Param(0x004f);
Init_Data_Param(0x00f7);
Init_Data_Param(0x0000);
Init_Data_Param(0x0006);
Init_Data_Param(0x0000);

//Display data write & Display on Seeting

Init_Data_Comm(0x00C7);
Init_Data_Param(0x00B0);

Init_Data_Comm(0x003A);
Init_Data_Param(0x0055);

Init_Data_Comm(0x0036);
Init_Data_Param(0x0008);

Init_Data_Comm(0x0036);
Init_Data_Param(0x0000);

Init_Data_Comm(0x002A);
Init_Data_Param(0x0000);
Init_Data_Param(0x0000);
Init_Data_Param(0x0000);
Init_Data_Param(0x00EF);

Init_Data_Comm(0x002B);
Init_Data_Param(0x0000);
Init_Data_Param(0x0000);
Init_Data_Param(0x0001);
Init_Data_Param(0x003F);

Init_Data_Comm(0x002C);

Init_Data_Comm(0x0029);
DelayX1ms(5);
    
```

11. Power On Sequence

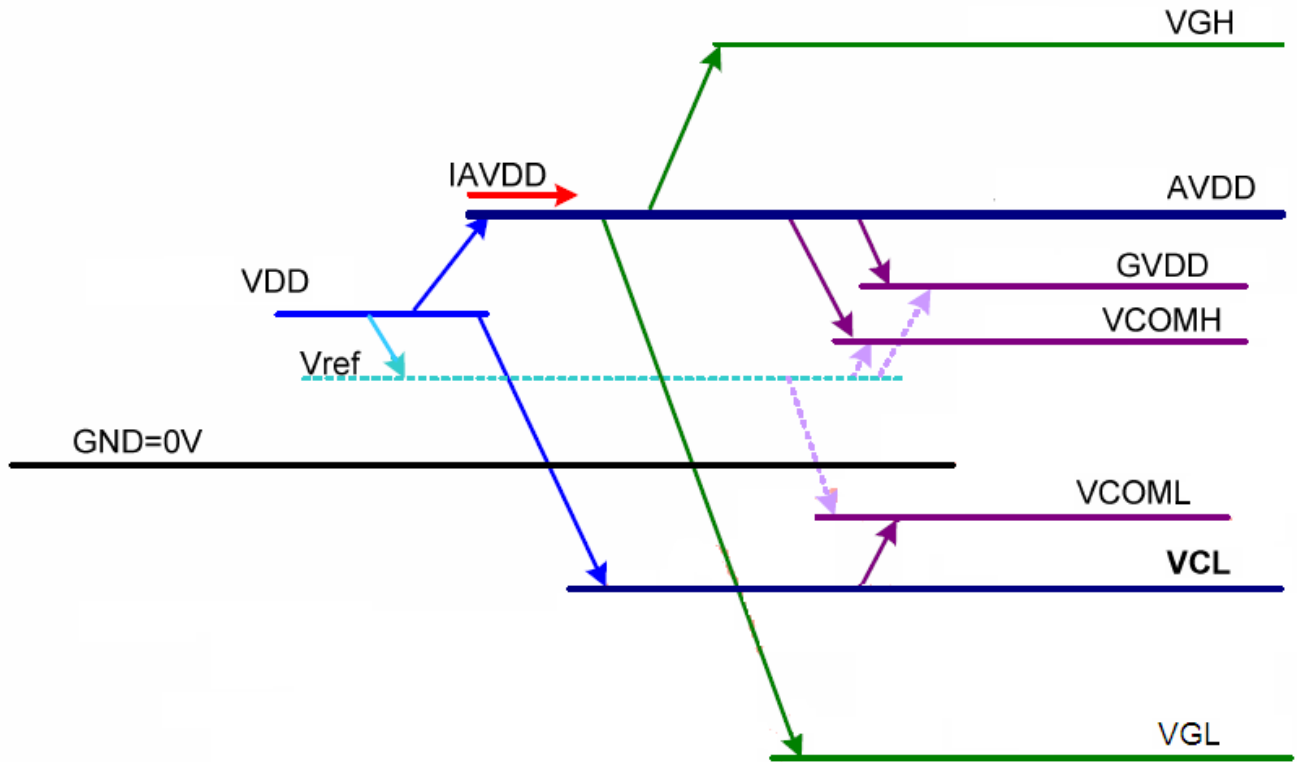

12. Optical Characteristics

12-1) Specification:

Ta=25°C

Parameter		Symbol	Condition	MIN.	TYP.	MAX.	Unit	Remarks
Viewing Angle	Horizontal	θ (Horizontal)	CR > 10	70	75	--	deg	Note 12-1
	Vertical	θ (12 o'clock)		45	50	--	deg	
		θ (6 o'clock)		55	60	--	deg	
Contrast Ratio		CR	At optimized Viewing angle	200	400	--	-	Note 12-2
Response time	Rise	Tr	$\theta = 0^\circ$	--	15	30	ms	Note 12-3
	Fall	Tf		--	25	50	ms	
Brightness		L	$\theta = 0^\circ / \phi = 0$	400	450	--	cd/m ²	Note 12-4
Luminance Uniformity		U	-	75	80	--	%	Note 12-6
Color Chromaticity	White	x	$\theta = 0^\circ / \phi = 0$	0.28	0.32	0.36	-	
		y		0.30	0.34	0.38	-	
	Red	x		0.55	0.59	0.63	-	
		y		0.26	0.30	0.34	-	
	Green	x		0.29	0.33	0.37	-	
		y		0.53	0.57	0.61	-	
	Blue	x		0.11	0.15	0.19	-	
		y		0.10	0.14	0.18	-	
LED Life Time			+25°C	20000	30000	--	hrs	Note 12-5
Cross Talk			$\theta = 0^\circ$	--	--	3.5	%	Note 12-7

Note 12-1: The definitions of viewing angles are as follow

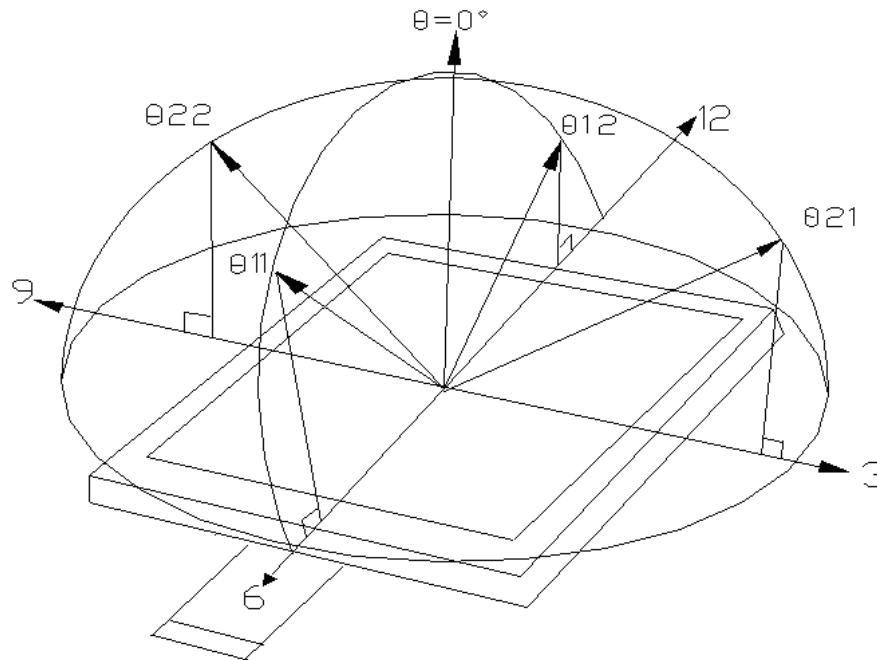

Note 12-2: The definition of contrast ratio $CR = \frac{\text{Luminance at gray level 63}}{\text{Luminance at gray level 0}}$

Note 12-3: Definition of Response Time T_r and T_f

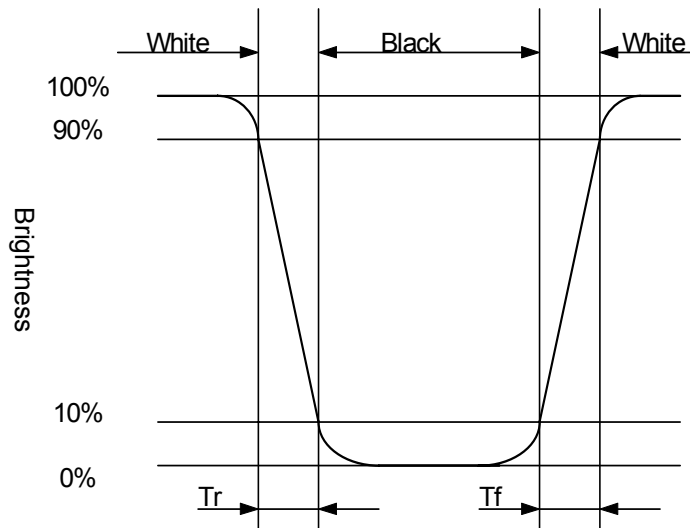

Note 12-4: Topcon BM-5A or BM-7 fast luminance meter 1° field of view is used in the testing

Note 12-5: The “LED Life time “ is defined as the module brightness decrease to 50% original Brightness that the ambient temperature is 25°C and $I_{LED} = 20mA$.

Note 12-6: The uniformity of LCD is defined as

$$U = \frac{\text{The Minimum Brightness of the 9 testing Points}}{\text{The Maximum Brightness of the 9 testing Points}}$$

Luminance meter : BM-5A or BM-7 fast(TOPCON)

Measurement distance : 500 mm +/- 50 mm

Ambient illumination : < 1 Lux

Measuring direction : Perpendicular to the surface of module

The test pattern is white (Gray Level 63).

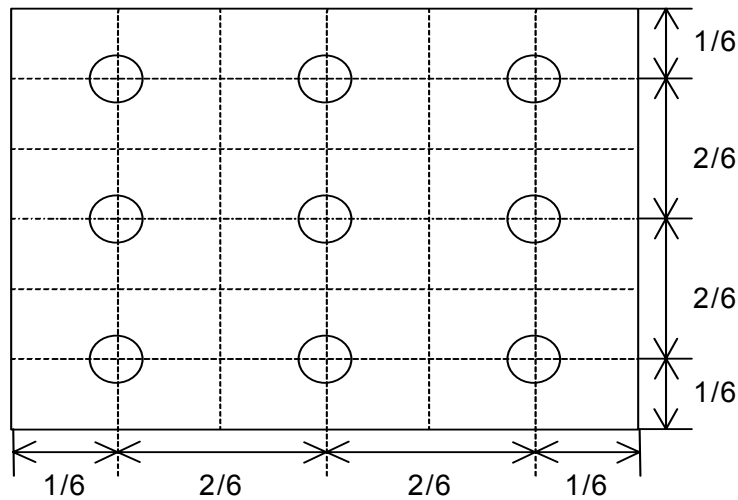

Note 12-7: Cross Talk (CTK) = $\frac{|Y_A - Y_B|}{Y_A} \times 100\%$

YA: Brightness of Pattern A

YB: Brightness of Pattern B

Luminance meter : BM 5A or BM-7 fast (TOPCON)

Measurement distance : 500 mm +/- 50 mm

Ambient illumination : < 1 Lux

Measuring direction : Perpendicular to the surface of module

Pattern A
(Gray Level 31)

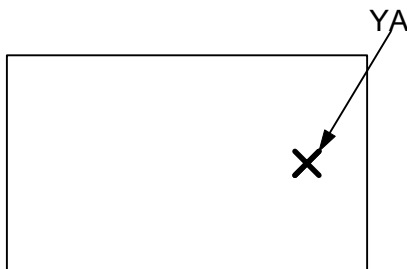

Pattern B
(Gray Level 31, central black box exclusive)

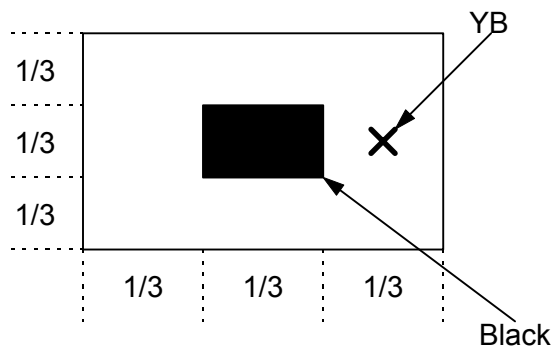

X: Measuring Point (A and B are at the same point.)

(Gray Level 0)

13. Handling Cautions

13-1) Mounting of module

- a) Please power off the module when you connect the input/output connector.
- b) Polarizer which is made of soft material and susceptible to flaw must be handled carefully.
- c) Protective film (Laminator) is applied on surface to protect it against scratches and dirt's. It is recommended to peel off the laminator before use and taking care of static electricity.

13-2) Precautions in mounting

- a) When metal part of the TFT-LCD module (shielding lid and rear case) is soiled, wipe it with soft dry cloth.
- b) Wipe off water drops or finger grease immediately. Long contact with water may cause discoloration or spots.
- c) TFT-LCD module uses glass, which breaks or cracks easily if dropped or bumped on hard surface. Please handle with care.
- d) Since CMOS LSI is used in the module. So take care of static electricity and earth yourself when handling.

13-3) Adjusting module

- a) Adjusting volumes on the rear face of the module have been set optimally before shipment.
- b) Therefore, do not change any adjusted values. If adjusted values are changed, the specifications described may not be satisfied.

13-4) Others

- a) Do not expose the module to direct sunlight or intensive ultraviolet rays for many hours.
- b) Store the module at a room temperature place.
- c) The voltage of beginning electric discharge may over the normal voltage because of leakage current from approach conductor by to draw lump read lead line around.
- d) If LCD panel breaks, it is possibly that the liquid crystal escapes from the panel. Avoid putting it into eyes or mouth. When liquid crystal sticks on hands, clothes or feet. Wash it out immediately with soap.
- e) Observe all other precautionary requirements in handling general electronic components.
- f) Please adjust the voltage of common electrode as material of attachment by 1 module.

13-5) Polarizer mark

The polarizer mark is to describe the direction of wide view angle film how to mach up with the rubbing direction.

14. Reliability Test

No	Test Item	Test Condition
1	High Temperature Storage Test	Ta = 95°C, 240 hrs
2	Low Temperature Storage Test	Ta = -40°C, 240 hrs
3	High Temperature Operation Test	Ta = 85°C, 240 hrs
4	Low Temperature Operation Test	Ta = -30°C, 240 hrs
5	High Temperature & High Humidity Operation Test	Ta = 60°C, 90%RH, 240 hrs (No Condensation)
6	Thermal Cycling Test (non-operating)	-25°C→70°C, 200 Cycles 30min 30min
7	Vibration Test (non-operating)	Frequency : 10 ~ 55 Hz, Amplitude : 1 mm Sweep time: 11 min Test Period: 6 Cycles for each direction of X, Y, Z
8	Shock Test (non-operating)	100G, 6ms Direction: X , Y , Z Cycle: 3 times
9	Electrostatic Discharge Test (non-operating)	200pF, 0Ω ±200V 1 time / each terminal

Ta: ambient temperature

Note : The protective film must be removed before temperature test.

[Criteria]

In the standard conditions, there is not display function NG issue occurred. (Including: line defect, no image).All the cosmetic specification is judged before the reliability stress.

15. Packing Diagram

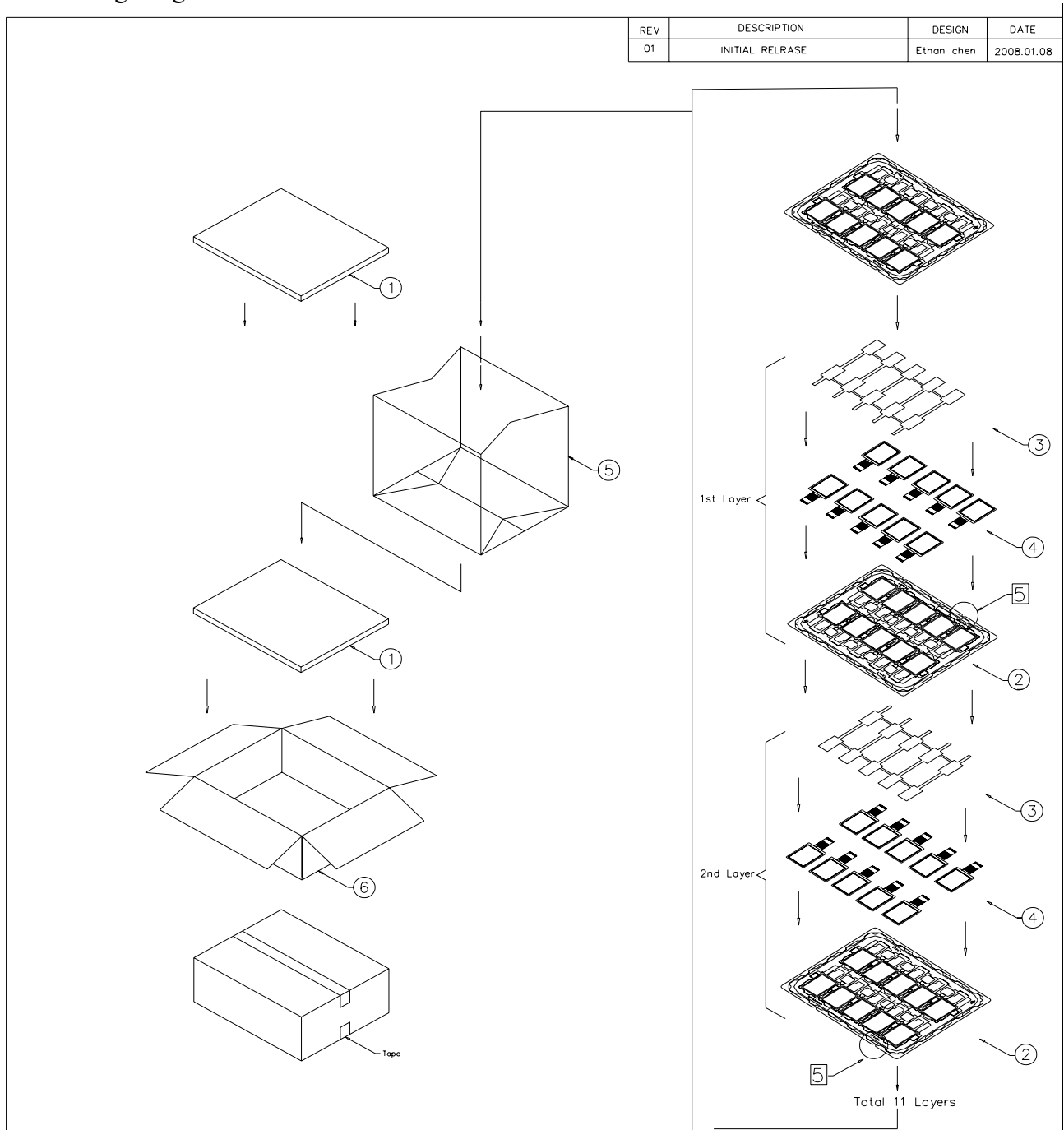

NOTE:

1. One layer include: 1 piece of cushion sheet, 10 pcs panel & 1 piece of tray.
2. Q'TY: 110 pcs panel/carton.
3. Dimension: 455*375*190mm
4. Weight: 7.0 KG
5. tray需180°交叉堆疊, 堆疊後可從側邊檢視圓弧防呆方向是否正確

6	50-0100091	CARTON INTERNAL	1	
5	50-0500041	摺口袋450*380*700mm	1	抗靜電
4		PD035QX1	110	
3	50-0200113	EPE CUSHION SHEET	11	抗靜電
2	50-0301991	TRAY	12	抗靜電
1	50-0300491	EPE FOAM	2	
ITEM	PART NO.	DESCRIPTION	QTY	REMARK

MTL.SPEC.		UNSPECIFIED TOL'S ±5.0mm		REMARK		 元太科技股份有限公司 Prime View International Co.,Ltd.	
		ANGLE					
		ROUGHNESS					
APPROVE	Frank Shin	'08.01.08	SCALE	UNIT	SHEET	DWG.TITLE	
CHECK	Frank Shin	'08.01.08	1:1	mm	1 OF 1	PD035QX1 PACKING Dim	
DESIGN	ETHAN	'08.01.08	MTL.NO.		DWG.NO.		REV. 01
							A4
							SIZE