

Version :4.0

TECHNICAL SPECIFICATION
MODEL NO. : PD035VL1

The content of this information is subject to be changed without notice.
Please contact PVI or its agent for further information.

Customer's Confirmation

Customer _____

Date _____

By _____

PVI's Confirmation

Confirmed By _____

Prepared By _____

Revision History

Rev.	Issued Date	Revised Contents
0.1	Oct.31 ,2006	Preliminary 0.1 ver
1.0	Feb,13,2007	Release version
2.0	Nov.13,2007	Modify Page 23: 16 Delete carton and change packing
3.0	Nov.23,2007	Modify Page23 12. Reliability Test Low Temperature Operation Test : -20°C change to -30°C
4.0	June.18.2008	Add Page 20: 14.Handling Cautions e) items of 14-1

TECHNICAL SPECIFICATION

CONTENTS

NO.	ITEM	PAGE
-	Cover	1
-	Revision History	2
-	Contents	3
1	Application	4
2	Features	4
3	Mechanical Specifications	4
4	Mechanical Drawing of TFT-LCD module	5
5	Input Terminals	7
6	Absolute Maximum Ratings	9
7	Electrical Characteristics	9
8	Pixel Arrangement	10
9	Display Color and Gray Scale Reference	11
10	Block Diagram	12
11	Interface Timing	13
12	Power On Sequence	16
13	Optical Characteristics	16
14	Handling Cautions	20
15	Reliability Test	22
16	Packing Diagram	23

1. Application

This data sheet applies to a color TFT LCD module, PD035VL1. The module applies to OA product, GPS, which require high quality flat panel display. If you must use in high reliability environment can't over reliability test condition. If you use PD035VL1, Prime View advises your system sides must use PVI-2003A which one generates signal to control PD035VL1

2. Features

- . Amorphous silicon TFT LCD panel with LED back-light unit
- . Pixel in stripe configuration
- . Thin and light weight
- . Display Colors : 262144 colors
- . Optimum Viewing Direction : 6 o'clock
- . LVDS transmission interface

3. Mechanical Specifications

Parameter	Specifications	Unit
Screen Size	3.5 (diagonal)	inch
Display Format	640×(R, G, B)×480	dot
Display Colors	262,144	
Active Area	72.00 (H)×52.56 (V)	mm
Pixel Pitch	0.1125 (H)×0.1095 (V)	mm
Pixel Configuration	Stripe	
Back-light	6-LED	
Outline Dimension	85.2 (W)×66.45(H)×8.45 (D) (Typ.)	mm
Weight	78±5	g
Surface treatment	AG	
Display mode	Normally white	
Gray scale inversion direction	6 o'clock [Note 13-2]	

4.Mechanical Drawing of TFT-LCD Module

Outline Drawing : Front View (unit mm)

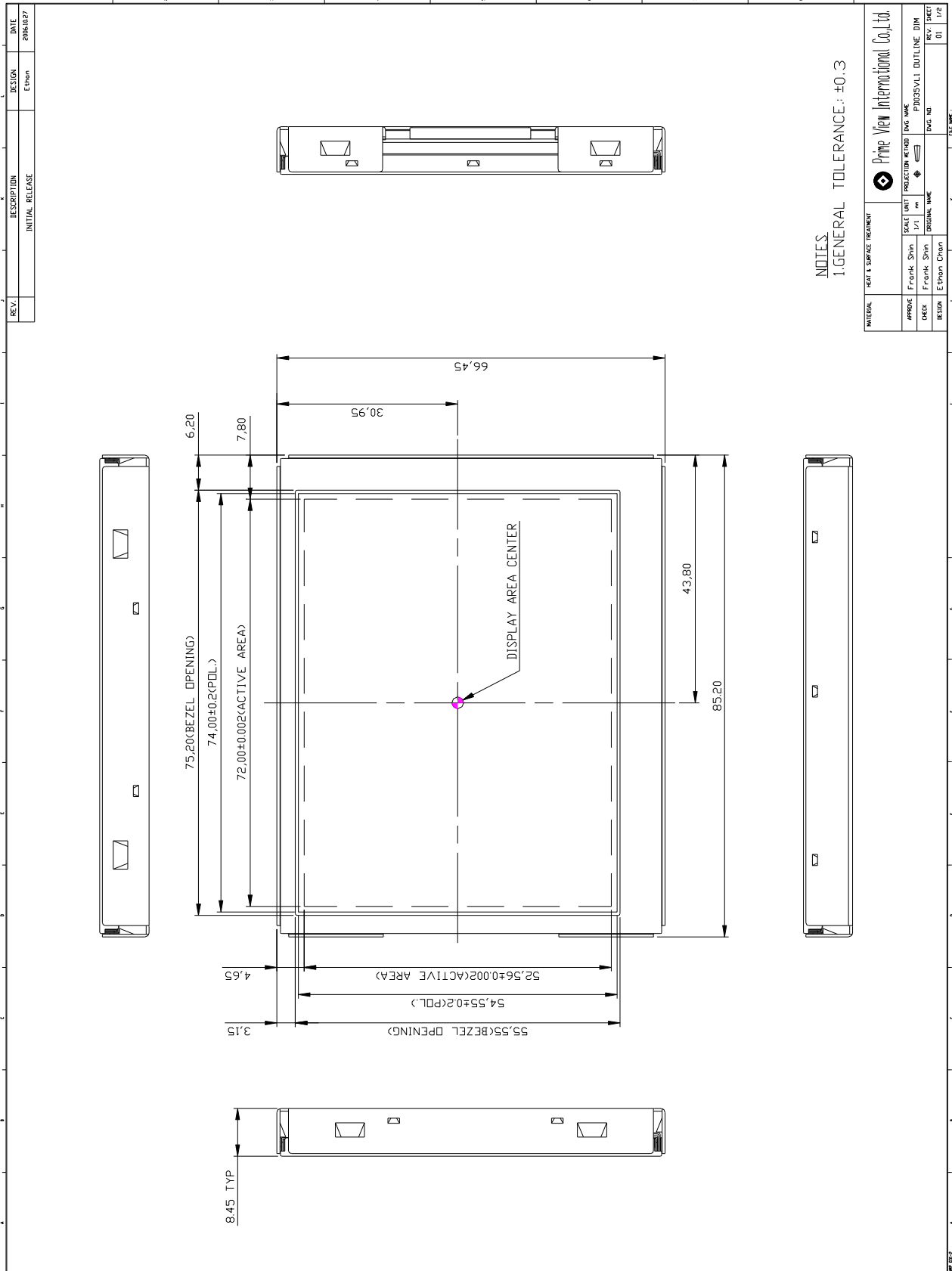

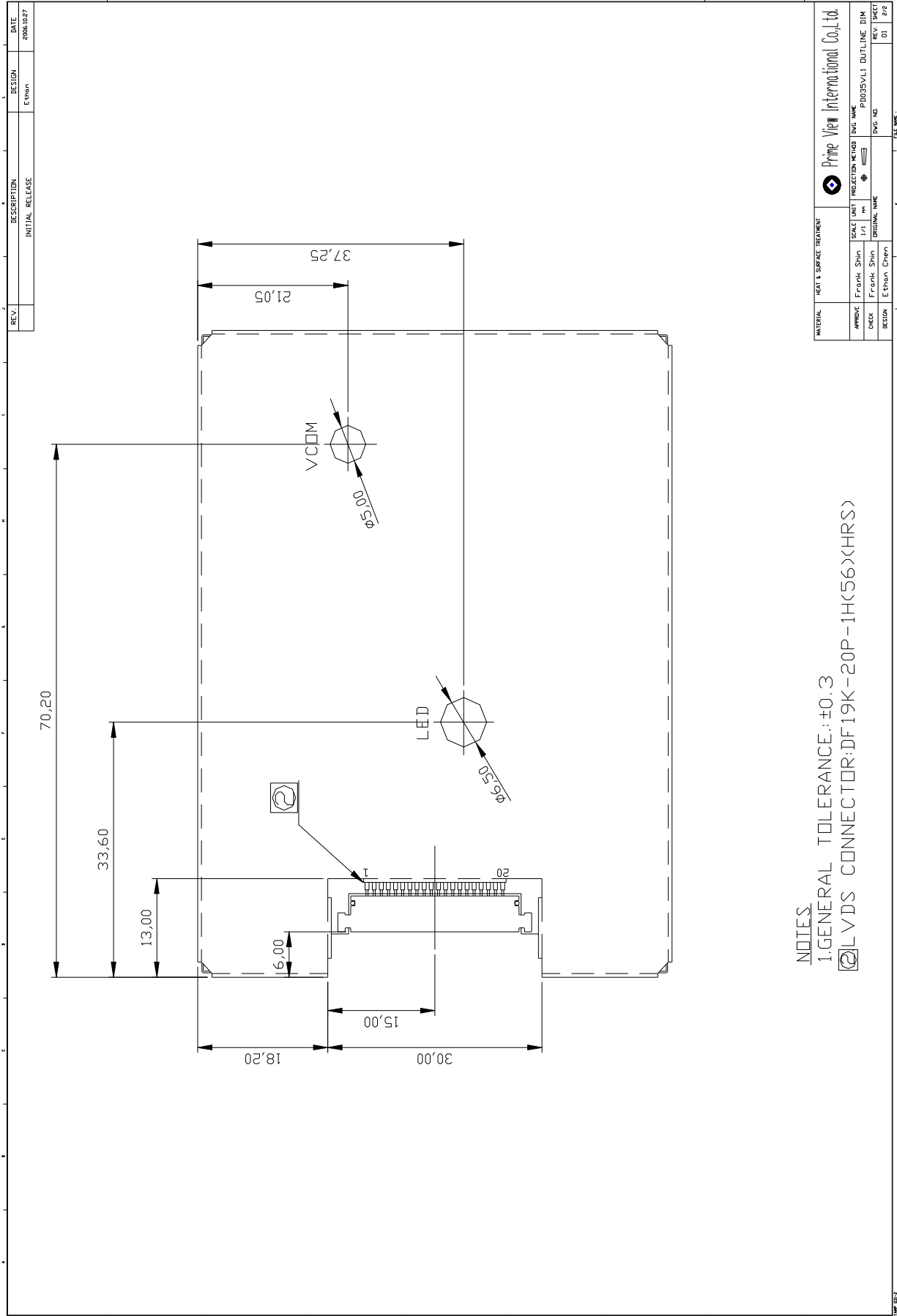

NOTES:
 1. GENERAL TOLERANCE: ±0.3
 2. LVDS CONNECTOR: DF19K-20P-1HK56(X)HRS)

5.Input Terminals

5-1) TFT-LCD Panel Driving

Connector type: DF19K-20P-1H(56)(HRS)

Pin No.	Symbol	Function	Remark
1	Vcc	+3.3V Power Supply	
2	Vcc	+3.3V Power Supply	
3	GND	Ground	
4	GND	Ground	
5	INO-	LVDS receiver signal channel 0	
6	INO+	LVDS receiver signal channel 0	
7	GND	Ground	
8	IN1-	LVDS receiver signal channel 1	
9	IN1+	LVDS receiver signal channel 1	
10	GND	Ground	
11	IN2-	LVDS receiver signal channel 2	
12	IN2+	LVDS receiver signal channel 2	
13	GND	Ground	
14	CLK-	LVDS receiver signal clock	
15	CLK+	LVDS receiver signal clock	
16	GND	Ground	
17	NC	No connection	
18	NC	No connection	
19	GND	Ground	
20	GND	Ground	

LVDS Interface Block Diagram

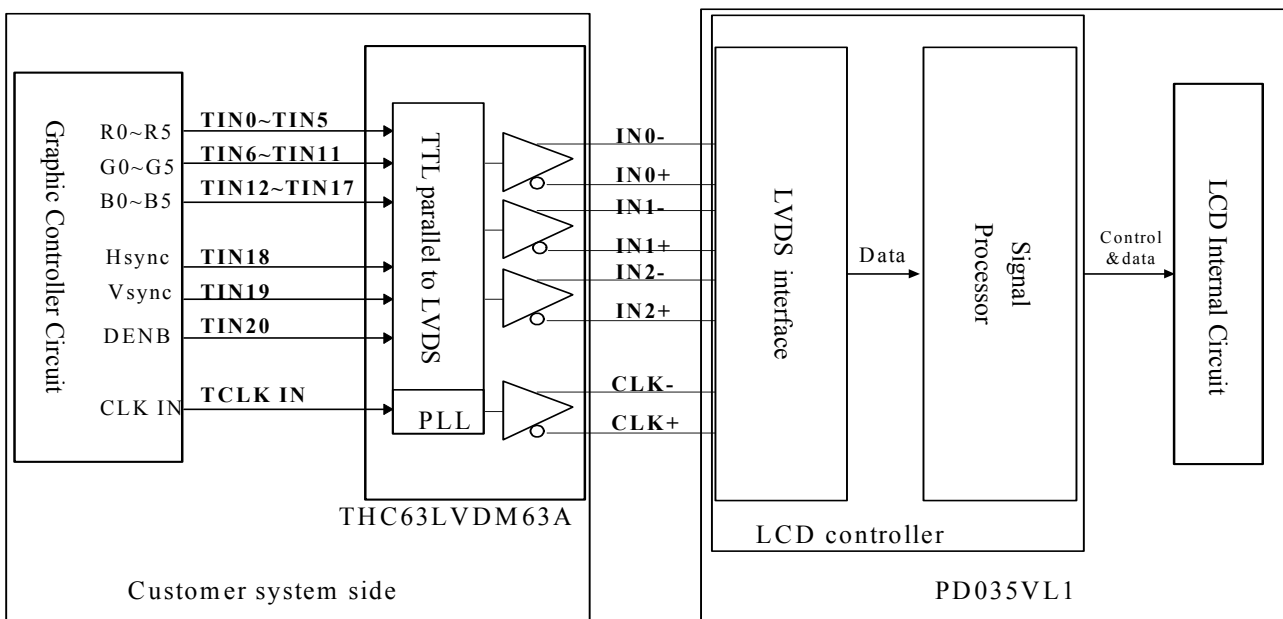

Recommended Transmitter (THC63LVDM63A Thine) to PD035VL1 interface Assignment:

Input terminal of THC63LVDM63A		Graphic controller output signal		Output signal symbol	To PD035VL1 interface terminal (Symbol)
Symbol	No.	Symbol	Function		
TIN0	44	R0	Red pixel data (LSB)	Tout0- Tout0+	No.5 : IN0- No.6 : IN0+
TIN1	45	R1	Red pixel data		
TIN2	47	R2	Red pixel data		
TIN3	48	R3	Red pixel data		
TIN4	1	R4	Red pixel data		
TIN5	3	R5	Red pixel data(MSB)		
TIN6	4	G0	Green pixel data (LSB)	Tout1- Tout1+	No.8 : IN1- No.9 : IN1+
TIN7	6	G1	Green pixel data		
TIN8	7	G2	Green pixel data		
TIN9	9	G3	Green pixel data		
TIN10	10	G4	Green pixel data		
TIN11	12	G5	Green pixel data(MSB)		
TIN12	13	B0	Blue pixel data(LSB)	Tout2- Tout2+	No.11 : IN2- No.12 : IN2+
TIN13	15	B1	Blue pixel data		
TIN14	16	B2	Blue pixel data		
TIN15	18	B3	Blue pixel data		
TIN16	19	B4	Blue pixel data		
TIN17	20	B5	Blue pixel data(MSB)		
TIN18	22	Hsync	Horizontal Synchronous Signal	TCLK out- TCLK out+	No.14 : CLK - No.15 : CLK+
TIN19	23	Vsync	Vertical Synchronous Signal		
TIN20	25	DENB	Compound Synchronization signal		
CLK in	26	CLK	Data sampling clock		

DENB input signal.

If customer wanted to off the DENB mode , you must keep the DENB always High or Low.

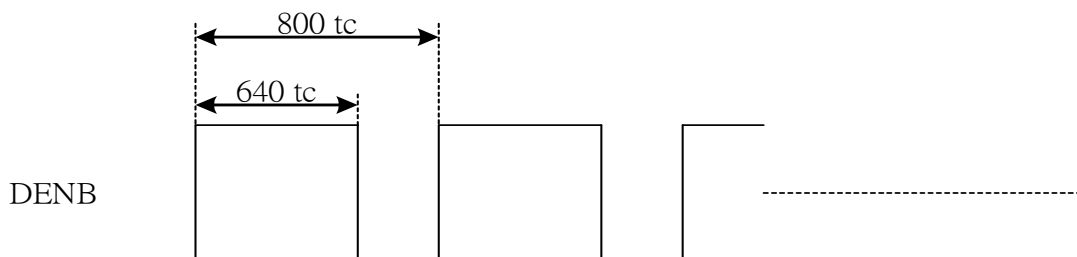

(tc: the period of sampling clock)

6. Absolute Maximum Ratings :

The followings are maximum values , which if exceeded, may cause faulty operation or damage to the unit.

GND=0V, Ta=25°C

Parameters	Symbol	MIN.	MAX.	Unit	Remark
Supply Voltage	V _{CC}	-0.3	+4.0	V	

7. Electrical Characteristics

7-1) Recommended Operating Conditions:

Ta = 25°C

Item	Symbol	Min.	Typ.	Max.	Unit	Remark
Supply Voltage	V _{CC}	3.0	3.3	3.6	V	
Current Dissipation	I _{CC}	-	455.4	496.8	mA	Note 7-1
LVDS Differential input high threshold	V _{TH}	-	-	100	mV	
LVDS Differential input low threshold	V _{TL}	-100	-	-		
V _{com} Voltage	V _{com}	-	2.6	-	V	

Note 7-1 : To test the current dissipation of VCC using the “color bars” testing pattern shown as below

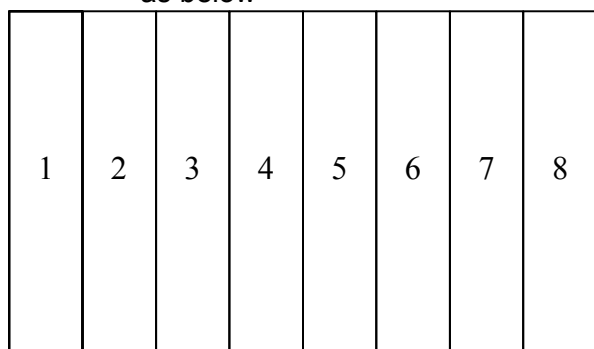

1. White
2. Yellow
3. Cyan
4. Green
5. Magenta
6. Red
7. Blue
8. Black

I_{DD} current dissipation testing pattern

7-2) Recommended driving condition for LED backlight

Ta = 25°C

Parameter	Symbol	Min	TYP	MAX	Unit	Remark
Supply voltage of LED backlight	V _{LED}	-	-	(11.4)	V	Note 7-2
Supply current of LED backlight	I _{LED1}	-	20	-	mA	Note 7-3
	I _{LED2}					
Backlight Power Consumption	P _{LED}	-	-	456	mW	Note 7-4/ Note 7-2

Note 7-2 : I_{LED} = 20mA, constant current

Note 7-3 : The LED driving condition is defined for each LED module. (3 LED Serial)

$$\text{Input current} = 20\text{mA} * 2 = 40\text{mA}$$

Note 7-4 : P_{LED} = V_{LED} * I_{LED1} + V_{LED} * I_{LED2} .

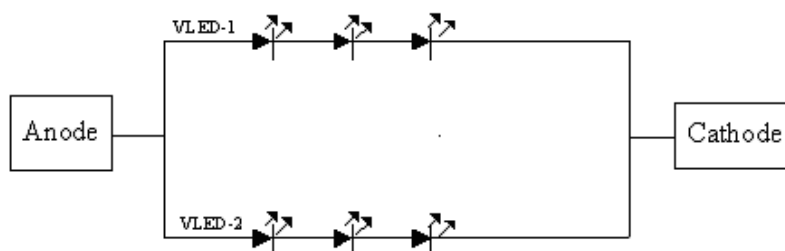

7-3) Power Consumption

Parameters	Symbol	Typ.	Max.	Unit	Remark
LCD Panel Power Consumption	-	1.5	1.8	W	
BackLight Power Consumption		-	0.5	W	
Total Power Consumption	-	-	2.3	W	

8. Pixel Arrangement

The LCD module pixel arrangement is the stripe.

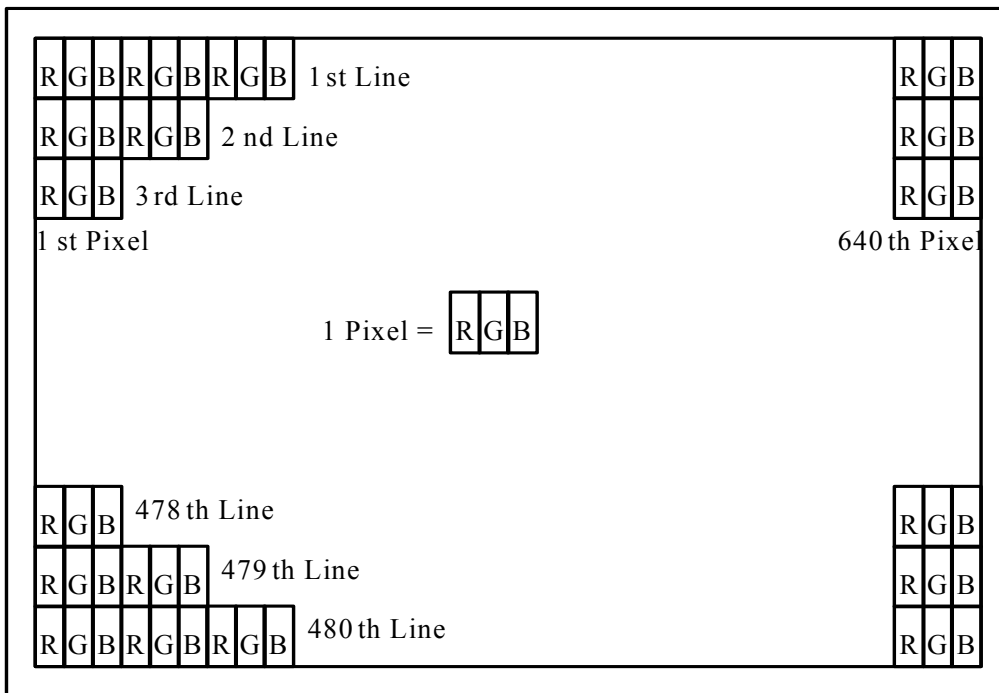

9. Display Color and Gray Scale Reference

Color		Input Color Data																	
		Red					Green					Blue							
		R5	R4	R3	R2	R1	R0	G5	G4	G3	G2	G1	G0	B5	B4	B3	B2	B1	B0
Basic Colors	Black	0	0	0	0	0	0	0	0	0	0	0	0	0	0	0	0	0	0
	Red (63)	1	1	1	1	1	1	0	0	0	0	0	0	0	0	0	0	0	0
	Green (63)	0	0	0	0	0	0	1	1	1	1	1	1	0	0	0	0	0	0
	Blue (63)	0	0	0	0	0	0	0	0	0	0	0	0	1	1	1	1	1	1
	Cyan	0	0	0	0	0	0	1	1	1	1	1	1	1	1	1	1	1	1
	Magenta	1	1	1	1	1	1	0	0	0	0	0	0	1	1	1	1	1	1
	Yellow	1	1	1	1	1	1	1	1	1	1	1	1	0	0	0	0	0	0
	White	1	1	1	1	1	1	1	1	1	1	1	1	1	1	1	1	1	1
Red	Red (00)	0	0	0	0	0	0	0	0	0	0	0	0	0	0	0	0	0	0
	Red (01)	0	0	0	0	0	1	0	0	0	0	0	0	0	0	0	0	0	0
	Red (02)	0	0	0	0	1	0	0	0	0	0	0	0	0	0	0	0	0	0
	Darker																		
	↓	↓	↓	↓	↓	↓	↓	↓	↓	↓	↓	↓	↓	↓	↓	↓	↓	↓	↓
	Brighter																		
	Red (61)	1	1	1	1	0	1	0	0	0	0	0	0	0	0	0	0	0	0
	Red (62)	1	1	1	1	1	0	0	0	0	0	0	0	0	0	0	0	0	0
Red (63)	1	1	1	1	1	1	0	0	0	0	0	0	0	0	0	0	0	0	
Green	Green (00)	0	0	0	0	0	0	0	0	0	0	0	0	0	0	0	0	0	0
	Green (01)	0	0	0	0	0	0	0	0	0	0	0	1	0	0	0	0	0	0
	Green (02)	0	0	0	0	0	0	0	0	0	0	1	0	0	0	0	0	0	0
	Darker																		
	↓	↓	↓	↓	↓	↓	↓	↓	↓	↓	↓	↓	↓	↓	↓	↓	↓	↓	↓
	Brighter																		
	Green (61)	0	0	0	0	0	0	1	1	1	1	0	1	0	0	0	0	0	0
	Green (62)	0	0	0	0	0	0	1	1	1	1	1	0	0	0	0	0	0	0
Green (63)	0	0	0	0	0	0	1	1	1	1	1	1	0	0	0	0	0	0	
Blue	Blue (00)	0	0	0	0	0	0	0	0	0	0	0	0	0	0	0	0	0	0
	Blue (01)	0	0	0	0	0	0	0	0	0	0	0	0	0	0	0	0	0	1
	Blue (02)	0	0	0	0	0	0	0	0	0	0	0	0	0	0	0	0	1	0
	Darker																		
	↓	↓	↓	↓	↓	↓	↓	↓	↓	↓	↓	↓	↓	↓	↓	↓	↓	↓	↓
	Brighter																		
	Blue (61)	0	0	0	0	0	0	0	0	0	0	0	0	1	1	1	1	0	1
	Blue (62)	0	0	0	0	0	0	0	0	0	0	0	0	1	1	1	1	1	0
Blue (63)	0	0	0	0	0	0	0	0	0	0	0	0	1	1	1	1	1	1	

10. Block Diagram

10-1) TFT-module Block Diagram

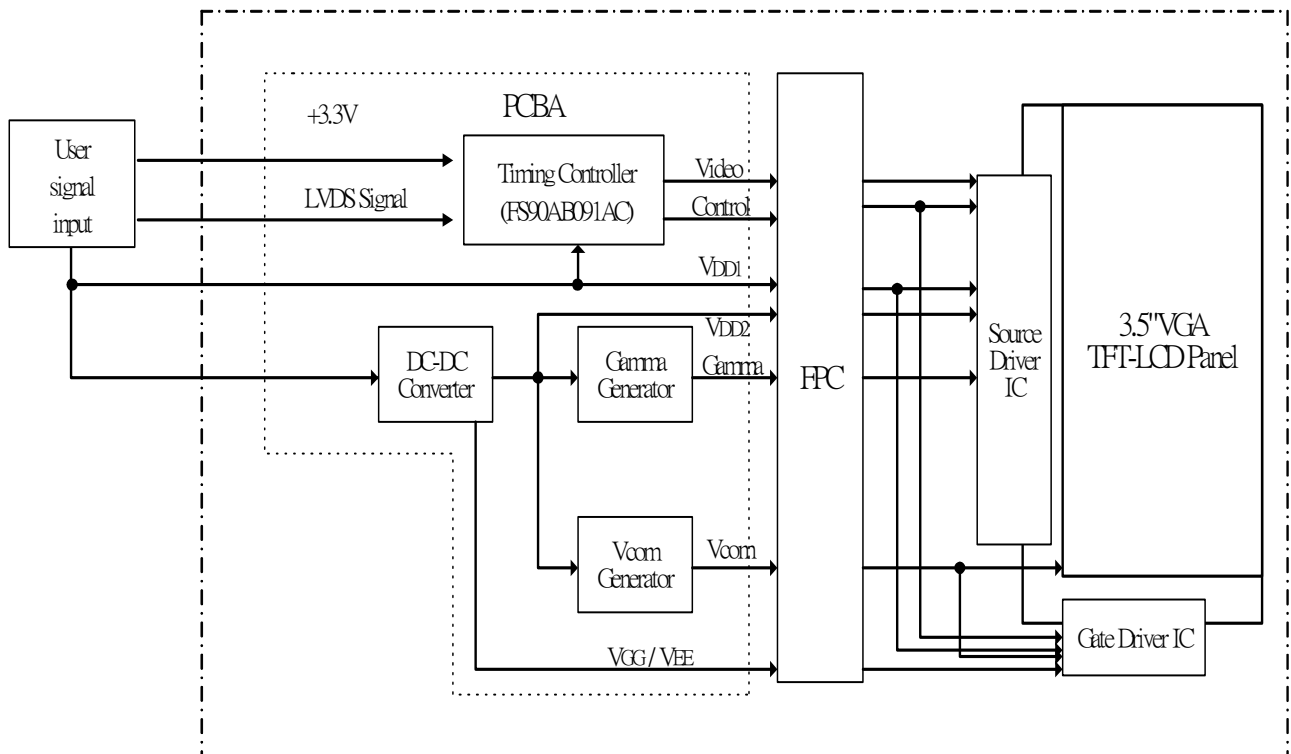

11. Interface Timing

11.1) Timing Parameters

		Symbol	Min.	Typ.	Max.	Unit	Remark	
Power supply		VCC	3.0	3.3	3.6	V		
CLK	Frequency	1/tc	-	25	-	MHz		
		tc	-	40	-	ns		
HSYNC	Period	Hp	-	32	-	us		
			-	800	-	tc		
	Display period	Hdp	-	640	-	tc		
	Pulse width	Hpw	-	96	-	tc		
	Back-porch	Hbp	-	46	-	tc		
	Front-porch	Hfp	-	18	-	tc		
	Hpw+Hbp			-	142	-	tc	
	Hsync-CLK	Hhc	10	-	Tc-10	ns		
Vsync-Hsync	Hvh	0	0	200	tc			
VSYNC	Period	Vp	-	16.8	-	ms		
			-	525	-	Hp		
	Display period	Vdp	-	480	-	Hp		
	Pulse width	Vpw	-	2	-	Hp		
	Back-porch	Vbp	-	33	-	Hp		
	Front-porch	Vfp	-	10	-	Hp		
	Vpw+Vbp			-	35	-	Hp	
DENB	Horizontal scanning period	T1	-	800	-	tc		
	Horizontal display period	T2	-	640	-	tc		
	Vertical display period	T3	-	480	-	T1		
	Frame cycling period	T4	520	525	800	T1		
R,G,B	CLK-DATA	Dcd	10	-	-	ns		
	DATA-CLK	Ddc	8	-	-	ns		

a.4 HSYNC, VSYNC relationship

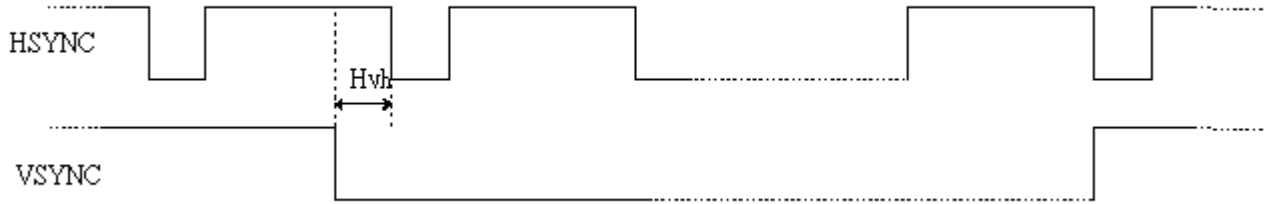

a.5 VSYNC timing

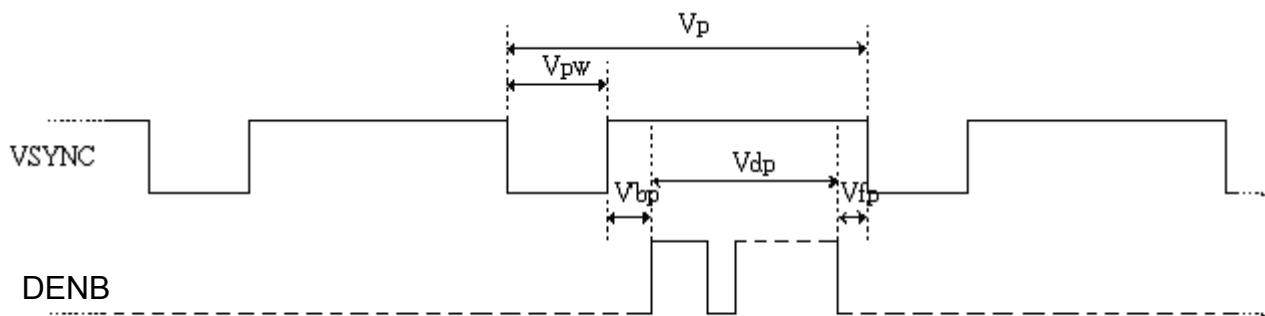

a.6 DENB timing

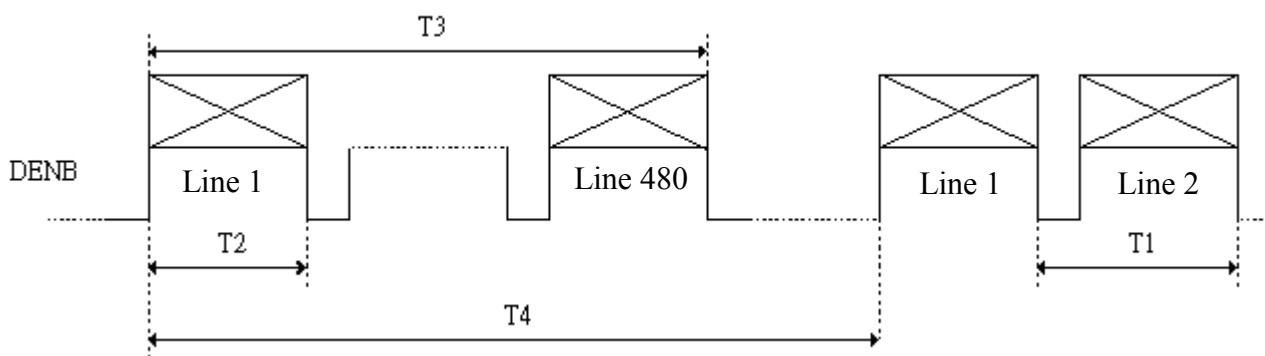

12. Power On Sequence

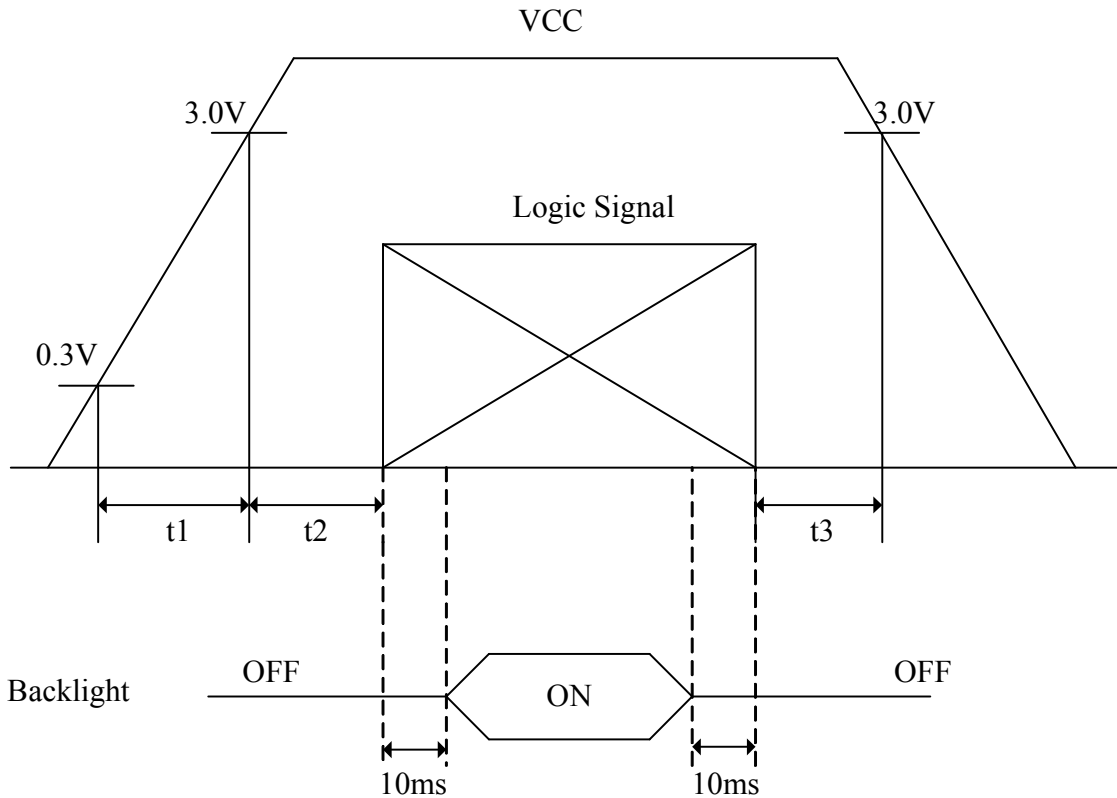

1. $0 < t1 \leq 20\text{ms}$
2. $0 < t2 \leq 50\text{ms}$
3. $0 < t3 \leq 1\text{s}$

13. Optical Characteristics

13-1) Specification:

Ta=25°C

Parameter	Symbol	Condition	MIN.	TYP.	MAX.	Unit	Remarks
Viewing Angle	Horizontal	$\theta 21, \theta 22$	± 45	± 50	-	deg	Note 13-2
	Vertical	$\theta 12$ (to 12 o'clock)	10	15	-	deg	
		$\theta 11$ (to 6 o'clock)	30	35	-	deg	
Contrast Ratio	CR	-	200	400	-	-	Note 13-4
Response time	Rise	Tr	-	15	30	ms	Note 13-3
	Fall	Tf	-	25	50	ms	
Brightness	L	$\theta = 0^\circ$	200	250	-	cd/m ²	Note 13-1
Uniformity	U	$\theta = 0^\circ$	70	75	-	%	Note 13-5
Cross Talk	-	$\theta = 0^\circ$	-	-	3.5	%	Note 13-6
White Chromaticity	x	-	0.28	0.31	0.34	-	Note 13-1
	y	-	0.30	0.330	0.36	-	
LED Life Time	-	Ta=25°C	20000	30000	-	hrs	Note 13-7

All the optical measurement shall be executed 30 minute after backlight being turn-on. The optical characteristics shall be measured in dark room (ambient illumination on panel surface less than 1 Lux). The measuring configuration shows as following figure.

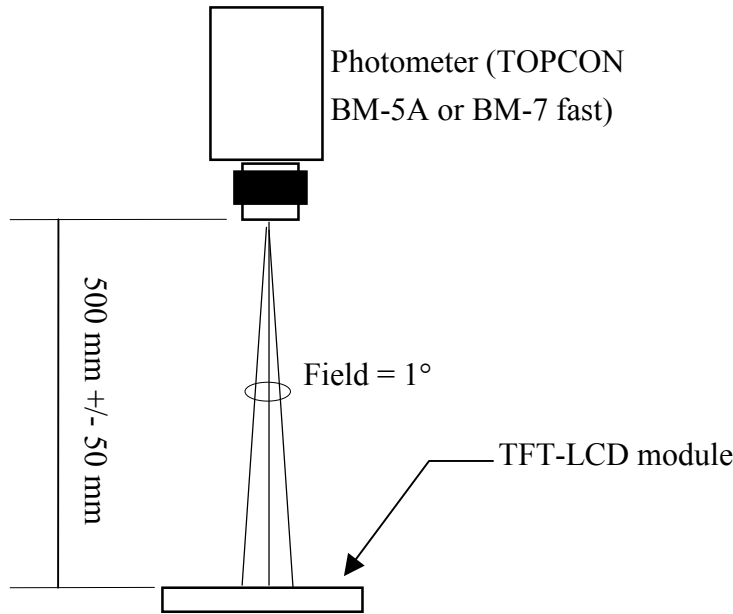

Optical characteristics measuring configuration

Note 13-1: 1.Topcon BM-5A or BM-7 fast luminance meter 1° field of view is used in the testing

Note 13-2: The definitions of viewing angles are as follow

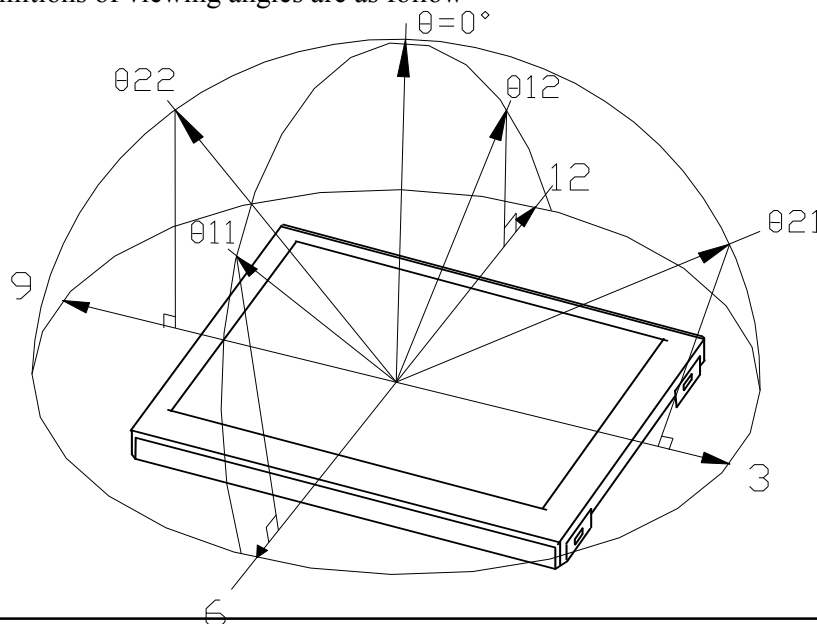

Note 13-3: Definition of Response Time T_r and T_f :

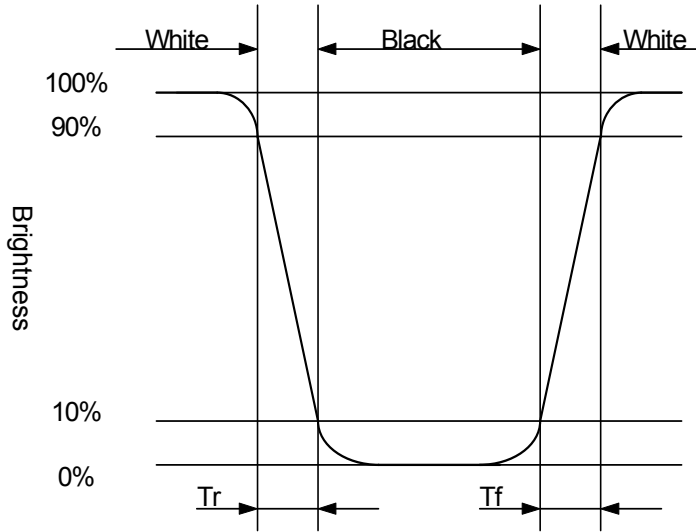

Note 13-4: The definition of contrast ratio $CR = \frac{\text{Luminance at gray level 63}}{\text{Luminance at gray level 0}}$

Note 13-5 : The uniformity of LCD is defined as

$$U = \frac{\text{The Minimum Brightness of the 9 testing Points}}{\text{The Maximum Brightness of the 9 testing Points}}$$

Luminance meter : BM-5A or BM-7 fast (TOPCON)

Measurement distance : 500 mm +/- 50 mm

Ambient illumination : < 1 Lux

Measuring direction : Perpendicular to the surface of module

The test pattern is white (Gray Level 63).

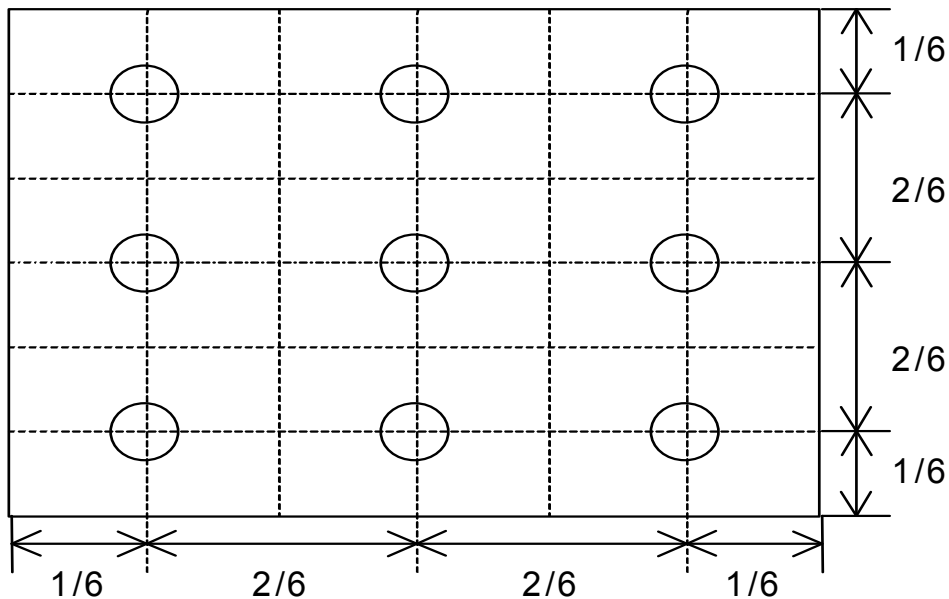

Note 13-6 : Cross Talk (CTK) = $\frac{|YA-YB|}{YA} \times 100\%$

YA : Brightness of Pattern A
 YB : Brightness of Pattern B

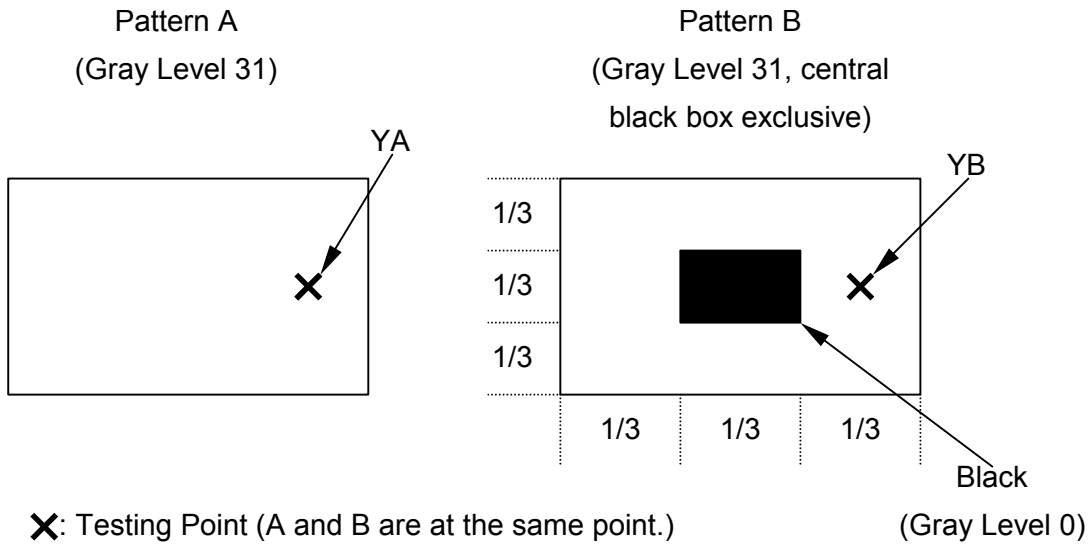

Note 13-7: The “LED Life time “ is defined as the module brightness decrease to 50% original Brightness that the ambient temperature is 25°C and I_{LED} =20mA.

14. Handling Cautions

14-1) Mounting of module

- a) Please power off the module when you connect the input/output connector.
- b) Polarizer which is made of soft material and susceptible to flaw must be handled carefully.
- c) Protective film (Laminator) is applied on surface to protect it against scratches and dirt.
- d) Please following the tear off direction as figure14-1 to remove the protective film as slowly as possible, so that electrostatic charge can be minimized.

14-2) Precautions in mounting

- a) When metal part of the TFT-LCD module (shielding lid and rear case) is soiled, wipe it with soft dry cloth.
- b) Wipe off water drops or finger grease immediately. Long contact with water may cause discoloration or spots.
- c) TFT-LCD module uses glass which breaks or cracks easily if dropped or bumped on hard surface. Please handle with care.
- d) Since CMOS LSI is used in the module. So take care of static electricity and earth yourself when handling.

14-3) Adjusting module

- a) Adjusting volumes on the rear face of the module have been set optimally before shipment.
- b) Therefore, do not change any adjusted values. If adjusted values are changed, the specifications described may not be satisfied.

14-4) Others

- a) Do not expose the module to direct sunlight or intensive ultraviolet rays for many hours.
- b) Store the module at a room temperature place.
- c) The voltage of beginning electric discharge may over the normal voltage because of leakage current from approach conductor by to draw lump read lead line around.
- d) If LCD panel breaks, it is possibly that the liquid crystal escapes from the panel. Avoid putting it into eyes or mouth. When liquid crystal sticks on hands, clothes or feet. Wash it out immediately with soap.
- e) Observe all other precautionary requirements in handling general electronic components.
- f) Please adjust the voltage of common electrode as material of attachment by 1 module.

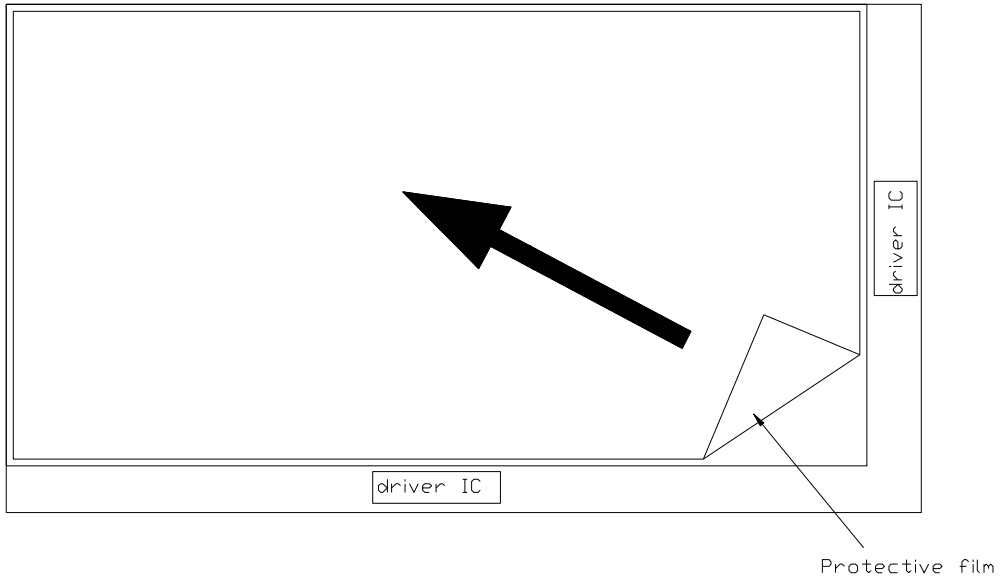

Figure 14-1 the way to peel off protective film

15. Reliability Test

No	Test Item	Test Condition
1	High Temperature Storage Test	Ta = +80 °C, 240 hrs
2	Low Temperature Storage Test	Ta = -30 °C, 240 hrs
3	High Temperature Operation Test	Ta = +70 °C, 240 hrs
4	Low Temperature Operation Test	Ta = -30 °C, 240 hrs
5	High Temperature & High Humidity Operation Test	Ta = +60 °C, 90%RH, 240 hrs
6	Thermal Cycling Test (non-operating)	-25°C → +70°C, 200 Cycles 30 min 30 min
7	Shock Test (non-operating)	100G, 6ms Direction: ±X, ±Y, ±Z Cycle: 3 times
8	Vibration Test (non-operating)	Frequency : 10 ~ 55 Hz Amplitude : 1 mm Sweep time: 11 mins Test Period: 6 Cycles for each direction of X, Y, Z
9	Electrostatic Discharge Test (non-operating)	Contact mode: ±8KV, 10times/point , 5 points/panel face Air mode: 150pF, 330Ω Air : ±15KV

Ta: ambient temperature

Note: The protective film must be removed before temperature test.

[Criteria]

In the standard conditions, there is not display function NG issue occurred. (including : line defect ,no image), All the cosmetic specification is judged before the reliability stress.

16. Packing Diagram

REV.	DESCRIPTION	DESIGN	DATE
△	Cancel the carton(50-0100101)	Ethan	2007.11.5

NOTE:

1. One layer include: 1 piece of cushion sheet, 12pcs module & 1 piece of tray.
2. Q'TY: 96 pcs panel/carton.
3. Dimension: 455*375*190mm
4. Weight: 7.7 KG

⑤. tray需180°交叉堆疊, 堆疊後可從側邊檢視圓弧防呆方向是否正確

ITEM	PART NO.	DESCRIPTION	QTY	REMARK
6	50-0100091	CARTON INTERNAL	1	
5	50-0500041	摺口袋450*380*700mm	1	抗靜電
4	PD035VL1		96	
3	50-0301701	PS TRAY	9	抗靜電
2	50-0200096	EPE CUSHION SHEET	8	抗靜電
1	50-0300491	EPE FOAM	2	

MTL.SPEC.	UNSPECIFIED TOL'S ±5.0mm	REMARK	元太科技股份有限公司 Prime View Internation Co.,Ltd.					
APPROVE	Frank Shin	'07.02.07				SCALE	UNIT	SHEET
CHECK	Frank Shin	'07.02.07				1:1	mm	1 OF 1
DESIGN	Ethan Chen	'07.02.07	MTL.NO.		DWG.NO.	REV. 01	A4 SIZE	