

<p>TECHNICAL SPECIFICATION</p> <p>MODEL NO. : PD035VX9</p>
--

The content of this information is subject to be changed without notice.
 Please contact E Ink or its agent for further information.

Customer's Confirmation

Customer _____

Date _____

By _____

Customer's Confirmation

Dep	PM	FAE	Panel Design	Electronic Design	Mechanical Design	Product Verification	Prepared by
SIGN				王 志 清	陳 毅 臣		任 欣 豪 2011/08/26

Revision History

Rev.	Issued Date	Revised Contents
0.1	Dec.13 ,2010	New
0.2	Feb.09 ,2011	Modify 4. Mechanical Drawing of TFT-LCD Module
0.3	Apr.20 ,2011	<ol style="list-style-type: none"> 1. Modify 5.Input / Output Terminals 2. Add 6. Touch Panel Characteristics 3. Add 11. Block Diagram 4. Add 12. Interface Timing
0.4	June.8 ,2011	<ol style="list-style-type: none"> 1. Modify 5.Input / Output Terminals 2. Modify 6-3) Durability Performances 3. Modify 11. Block Diagram 4. Modify 12.Interface Timing 5. Modify 14. Optical Characteristics
0.5	Aug.2 ,2011	<ol style="list-style-type: none"> 1. Modify 4. Mechanical Drawing of TFT-LCD Module 2. Add Connector type 3. Modify 6-2 Electrical Performances 4. Add 8-2) Backlight driving 5. Modify 14. Optical Characteristics 6. Modify 16. Reliability Test
0.6	Aug.26 ,2011	<ol style="list-style-type: none"> 1. Modify 3.Mechanical Specifications 2. Modify 8-1) Operation Condition 3. Add 8-2) DC Characteristics for Panel Driving 4. Add 13.Power On Sequence

TECHNICAL SPECIFICATION CONTENTS

<i>NO.</i>	<i>ITEM</i>	<i>PAGE</i>
-	Cover	1
-	Revision History	2
-	Contents	3
1	Application	4
2	Features	4
3	Mechanical Specifications	4
4	Mechanical Drawing of TFT-LCD module	5
5	Input Output Terminals	6
6	Touch Panel Characteristics	9
7	Absolute Maximum Ratings	10
8	Electrical Characteristics	11
9	Pixel Arrangement	12
10	Display Color and Gray Scale Reference	13
11	Block Diagram	14
12	Interface Timing	15
13	Power On Sequence	23
14	Optical Characteristics	28
15	Handling Cautions	32
16	Reliability Test	33
17	Packing	34

1.Application

This data sheet applies to a color TFT LCD module, PD035VX9. The module applies to OA product, GPS, which require high quality flat panel display. If you must use in high reliability environment can't over reliability test condition.

2. Features

- . Amorphous silicon TFT LCD panel with LED back-light unit
- . Pixel in stripe configuration
- . Display Colors : 262,144 colors
- . Optimum Viewing Direction : 6 o'clock
- . Module with resistive type touch panel.

3.Mechanical Specifications

Parameter	Specifications	Unit
Screen Size	3.5 (diagonal)	inch
Display Format	480×(R, G, B)×640	dot
Display Colors	262,144	
Active Area	53.28 (H)×71.04 (V)	mm
Pixel Pitch	0.111 (H)×0.111 (V)	mm
Pixel Configuration	Stripe	
Outline Dimension	64 (H)×85 (V)×4.2 (D) 64 (H)×85 (V)×6.1 (D) (Components side)	mm
Back-light	9-LEDs	
Weight	44±4.4	g
Surface treatment	Anti-Glare	
Surface treatment of Touch Panel	3H	
Display mode	Normally white	
Gray scale inversion direction	6 o'clock [ref to Note 13-1]	

4. Mechanical Drawing of TFT-LCD Module

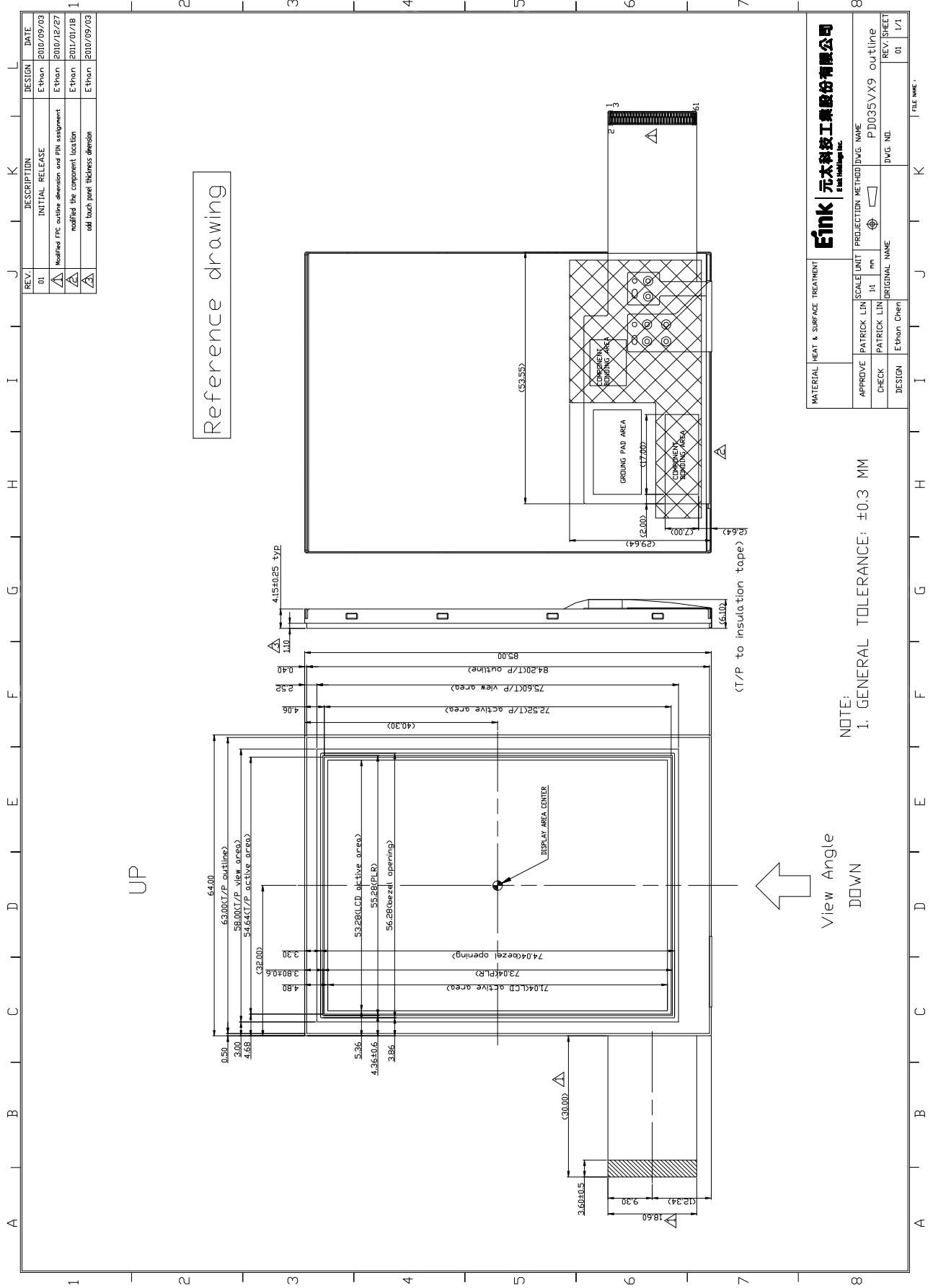

5.Input / Output Terminals

Connector type: 61FXZ-RSM1-GAN-ETF(LF)(SN)

Pin NO.	Symbol	Function	Remark
1	GND	Ground	
2	YU	Y axis position(Top)	
3	XR	X axis position(Right)	
4	YD	Y axis position(Bottom)	
5	XL	X axis position(Left)	
6	GND	Ground	
7	EXTC	Extended command set enable.	Note5-1
8	VCC	Power supply for analog circuit	Note5-2
9	NC	NC	
10	VCI	Power supply for digital circuit	Note5-2
11	NC	NC	
12	IOVCC	Power supply Interface pins	Note5-2
13	IM0	MPU Interface Select Pin	Note5-3
14	IM1	MPU Interface Select Pin	
15	IM2	MPU Interface Select Pin	
16	IM3	MPU Interface Select Pin	
17	RESX	Reset Input Pin	
18	NC	NC	
19	NC	NC	
20	NC	NC	
21	NC	NC	
22	NC	NC	
23	NC	NC	
24	DB17	Parallel data bus	
25	DB16	Parallel data bus	
26	DB15	Parallel data bus	
27	DB14	Parallel data bus	
28	DB13	Parallel data bus	
29	DB12	Parallel data bus	
30	DB11	Parallel data bus	
31	DB10	Parallel data bus	
32	DB9	Parallel data bus	
33	DB8	Parallel data bus	
34	DB7	Parallel data bus	
35	DB6	Parallel data bus	

36	DB5	Parallel data bus	
37	DB4	Parallel data bus	
38	DB3	Parallel data bus	
39	DB2	Parallel data bus	
40	DB1	Parallel data bus	
41	DB0	Parallel data bus	
42	RDX	8080 system (RDX): Serves as a read signal and read data at the rising edge.	
		- 8080 system (WRX): Serves as a write signal and writes data at the rising edge.	
43	WRX_DCX	- Serial interface (DCX): The signal for command or parameter select.	
		- 8080 system (DCX): The signal for command or parameter select.	
44	DCX_SCL	- Serial interface (SCL): Serial clock input.	
45	CSX	Chip select	
46	SDA	Serial data input / output.	
47	VSYNC	Frame synchronization signal	
48	HSYNC	Line synchronization signal	
49	ENABLE	- Data enable signal for RGB interface operation.	
50	DOTCLK	- Dot clock signal for RGB interface operation.	
51	NC	NC	
52	NC	NC	
53	NC	NC	
54	NC	NC	
55	NC	NC	
56	NC	NC	
57	NC	NC	
58	PWM_OUT	- Back light control pin. The PWM frequency output for LED driver control.	
		- Back light control pin. This pin is connected to external LED driver, It's a LED	
59	BC_CTL	driver control pin which is used for turning ON/OFF of LED back light.	
60	LED-	Cathode of LED	
61	LED+	Anode of LED	

Note : 5-1

Extended command set enable :

Low: extended command set is discarded.

High: extended command set is accepted.

Note : 5-2

VCC : Connect to an external power supply of 3 V.

VCI : Connect to an external power supply of 3 V.

IOVCC : Connect to an external power supply of 3 V.

Note : 5-3

MPU Interface Select Pin

IM3	IM2	IM1	IM0	Interface	Data Pin in Use
0	0	1	0	8080 16-bit bus interface DB[15:0]	DB[15:0]
0	1	0	1	Serial interface	SDA

6. Touch Panel Characteristics

6-1) Pin assignment

Pin No.	Symbol	Function	Remark
2	YU	Upper electrode Y(Upper side)	
3	XR	Lower electrode X(Right side)	
4	YD	Upper electrode Y(Down side)	
5	XL	Lower electrode X(Left side)	

6-2) Electrical Performances

Parameters	Symbol	MIN.	Typ.	MAX.	Unit	Remark
Terminal Resistance	X	220	-	610	Ω	
	Y	260	-	900	Ω	
Input Voltage	VT	-	5.0	-	V	
Linearity(X ,Y direction)		-	-	± 1.5	%	
Insulation Impedance		20	-	-	M Ω	DC=25V
Response Time		-	15	-	ms	
Operation Force		-	-	80	g	Note 6 - 1

Note 6-1: Input through 0.8R stylus or R8.0mm finger.

6-3) Durability Performances

1. Hitting Durability:

- (1) $\geq 1,000,000$ times.
- (2) End shape: R8.0mm , hardness50~60°
- (3) Load force: 200gf
- (4) Frequency: 3HZ
- (5) By Silicon rubber tapping at same points.

2. Sliding Durability:

- (1) $\geq 100,000$ times.
- (2) End shape: R0.8mm
- (3) Loaf force: 200gf
- (4) Writing speed: 300 mm/sec
- (5) Material of Pen: poly-acetal resin
- (6) Writing length: 35 mm

6-4) Integration Design Guide

Avoid the design that Front-case overlap and press on the active area of the touch-panel.
Give enough gap (over 0.5mm at compressed) between the front case and touch-panel to protect wrong operating.

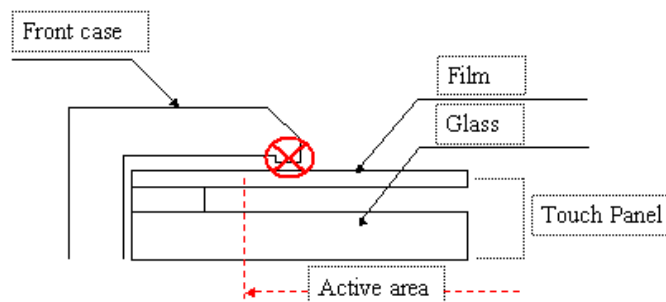

Use a buffer material (Gasket) between the touch-panel and front-case to protect damage and wrong operating.

Avoid the design that buffer material overlap and press on the inside of touch-panel viewing area.

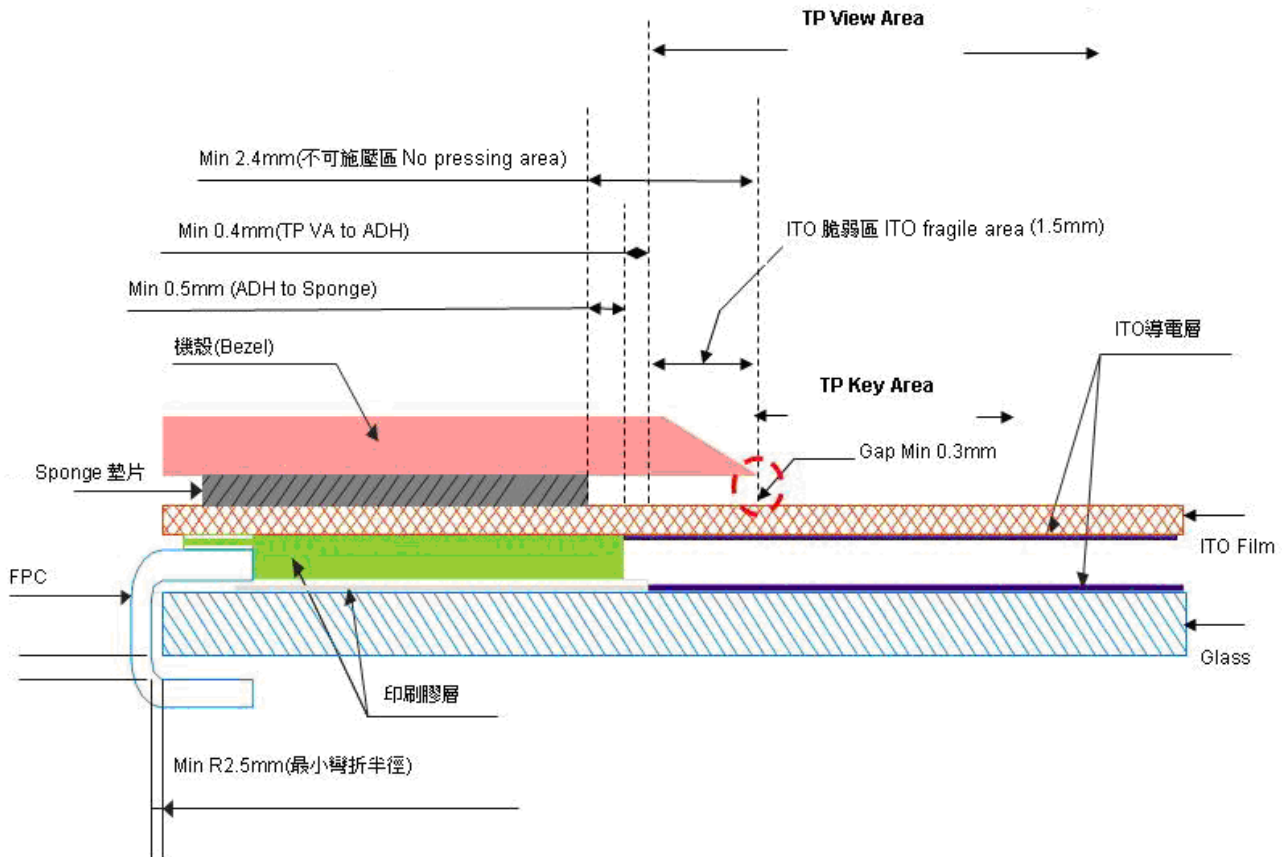

Note: We strongly suggest to follow above design guide to avoid the linear defect happened on the touch panel.

7. Absolute Maximum Ratings:

VSS=0V, Ta=25°C

Item	Symbol	Unit	Value	Note
Supply voltage	VCI	V	-0.3~+5.0	
Supply voltage (Logic)	IOVCC, VCC	V	-0.3~+4.6	
Supply voltage (Digital)	VCORE	V	-0.3~+2.4	
Driver supply voltage	VGH-VGL	V	-0.3~+33.0	
Logic input voltage range	VIN	V	-0.3~IOVCC+0.3	
Logic output voltage range	VOUT	V	-0.3~IOVCC+0.3	
Operating temperature	Topr	°C	-20~+70	
Storage temperature	Tstg	°C	-30~+80	

8. Electrical Characteristics

8-1) Operation Condition

GND = 0V , Ta = 25°C

Item	Symbol	Min.	Typ.	Max.	Unit	Remark
Supply Voltage	V _{DD1}	2.5	(2.8)	3.3	V	
Current Dissipation	I _{DD1}	--	(44.8)	--	mA	
Digital input voltage	High Level	V _{IN}	0.7 V _{DD1}	-	V _{DD1}	mV
	Low Level	V _{IL}	-0.3	-	0.3V _{DD1}	

(): reference only.

8-2) DC Characteristics for Panel Driving

Item	Symbol	Condition	Min.	Typ.	Max.	Unit	Note
Power & Operation Voltage							
Analog operating voltage	V _{CI}	-	2.5	2.8	3.3	V	Note1
Digital operating voltage	V _{CC}	-	2.5	2.8	3.3	V	Note1
Logic operating voltage	IOVCC	-	2.5	2.8	3.3	V	Note1
Input high voltage	V _{IH}	IOVCC=1.65~3.3V	0.7*IOVCC		IOVCC	V	Note1
Input low voltage	V _{IL}	IOVCC=1.65~3.3V	-0.3		0.3*IOVCC	V	Note1
Output high voltage	V _{OH}	IOVCC=1.65~3.3V	0.8*IOVCC			V	Note1
Output low voltage	V _{OL}	IOVCC=1.65~3.3V			0.2*IOVCC	V	Note1
Digital operating voltage	V _{CORE}	Digital block power supply	-	1.5	-	V	Note2
Gate Driver High Voltage	V _{GH}	-	10.0	12	16.0	V	
Gate Driver Low Voltage	V _{GL}	-	-16.0	-10	-9.0	V	
Driver Supply Voltage	-	V _{GH} -V _{GL}	19	-	32	V	
VCOM Operation							
VCOM Amplitude Voltage	V _{COM}	-	0	-1.36	-2.0	V	Note3
Source Driver							
Source Output Range	V _{sout}	-	0.1	-	V _{REG1OUT} -0.1	V	Note4
Positive Gamma Reference Voltage	V _{REG1OUT}	-	3.6	-	5.5	V	
Negative Gamma Reference Voltage	V _{REG2OUT}	-	-5.5	-	-3.6	V	
Source Output Setting Time	Tr	Below with 99% precision	-	15	20	uS	Note3.4
Output Deviation Voltage (Source Output channel)	V _{dev}	Sout>=4.2V	-	-	20	mV	Note3
		Sout<=0.8V	-	-	15	mV	-
Output Offset Voltage	V _{OFSET}	-	-	-	35	mV	Note3
Booster Operation							
1 st Booster (V _{CIx2}) Voltage	DDVDH	-	4.7		6.0	V	
1 st Booster (V _{CIx2}) Voltage	DDVDL	-	-6.0		-4.7	V	
1 st Booster (V _{CIx2}) Drop Voltage	V _{CI1x2 drop}	loading=1mA	-	-	5	%	
Liner Range	V _{liner}	-	0.2	-	DDVDH-0.2	V	

Note 1: IOVCC=1.65 to 3.3V, VCC=VCI=2.5 to 3.3V, AGND=DGND=0V, Ta=-30 to 70 (to +85 no damage) °C.

Note2: Please supply digital IOVCC voltage equal or less than analog VCI voltage.

Note3: Source channel loading = 10pF/channel, Gate channel loading = 50pF/channel

Note4: The Max. Value is between with Note 3 measure point and Gamma setting value

8-3) Backlight driving

Ta = 25°C

Parameter	Symbol	Min	TYP	MAX	Unit	Remark
Supply voltage of LED backlight	V _{LED}	-	9.6	(10.5)	V	Note 8-1
Supply current of LED backlight	I _{LED}	-	60	-	mA	Note 8-2
Backlight Power Consumption	P _{LED}	-	0.58	0.63	W	Note 8-1 /Note 8-3

(): reference only.

Note 8-1: I_{LED}= 60mA, constant current

Note 8-2: The LED driving condition is defined for each LED module. (3 LED Serial)

Input current =20mA *3 =60mA

Note 8-3: P_{LED} = V_{LED1} * I_{LED1} + V_{LED2} * I_{LED2} + V_{LED3} * I_{LED3}

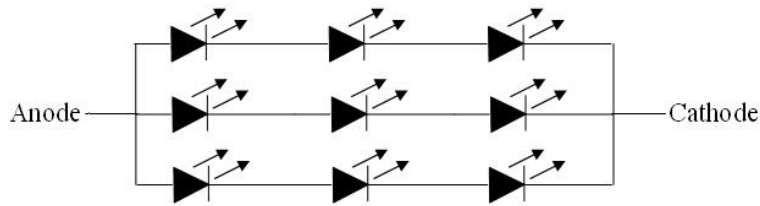

9. Pixel Arrangement

TBD

10. Display Color and Gray Scale Reference

Color		Input Color Data																	
		Red						Green						Blue					
		R5	R4	R3	R2	R1	R0	G5	G4	G3	G2	G1	G0	B5	B4	B3	B2	B1	B0
Basic Colors	Black	0	0	0	0	0	0	0	0	0	0	0	0	0	0	0	0	0	0
	Red (63)	1	1	1	1	1	1	0	0	0	0	0	0	0	0	0	0	0	0
	Green (63)	0	0	0	0	0	0	1	1	1	1	1	1	0	0	0	0	0	0
	Blue (63)	0	0	0	0	0	0	0	0	0	0	0	0	1	1	1	1	1	1
	Cyan	0	0	0	0	0	0	1	1	1	1	1	1	1	1	1	1	1	1
	Magenta	1	1	1	1	1	1	0	0	0	0	0	0	1	1	1	1	1	1
	Yellow	1	1	1	1	1	1	1	1	1	1	1	1	0	0	0	0	0	0
	White	1	1	1	1	1	1	1	1	1	1	1	1	1	1	1	1	1	1
Red	Red (00)	0	0	0	0	0	0	0	0	0	0	0	0	0	0	0	0	0	0
	Red (01)	0	0	0	0	0	1	0	0	0	0	0	0	0	0	0	0	0	0
	Red (02)	0	0	0	0	1	0	0	0	0	0	0	0	0	0	0	0	0	0
	Darker																		
	↓	↓	↓	↓	↓	↓	↓	↓	↓	↓	↓	↓	↓	↓	↓	↓	↓	↓	↓
	Brighter																		
	Red (61)	1	1	1	1	0	1	0	0	0	0	0	0	0	0	0	0	0	0
	Red (62)	1	1	1	1	1	0	0	0	0	0	0	0	0	0	0	0	0	0
Red (63)	1	1	1	1	1	1	0	0	0	0	0	0	0	0	0	0	0	0	
Green	Green (00)	0	0	0	0	0	0	0	0	0	0	0	0	0	0	0	0	0	0
	Green (01)	0	0	0	0	0	0	0	0	0	0	0	1	0	0	0	0	0	0
	Green (02)	0	0	0	0	0	0	0	0	0	0	1	0	0	0	0	0	0	0
	Darker																		
	↓	↓	↓	↓	↓	↓	↓	↓	↓	↓	↓	↓	↓	↓	↓	↓	↓	↓	↓
	Brighter																		
	Green (61)	0	0	0	0	0	0	1	1	1	1	0	1	0	0	0	0	0	0
	Green (62)	0	0	0	0	0	0	1	1	1	1	1	0	0	0	0	0	0	0
Green (63)	0	0	0	0	0	0	1	1	1	1	1	1	0	0	0	0	0	0	
Blue	Blue (00)	0	0	0	0	0	0	0	0	0	0	0	0	0	0	0	0	0	0
	Blue (01)	0	0	0	0	0	0	0	0	0	0	0	0	0	0	0	0	0	1
	Blue (02)	0	0	0	0	0	0	0	0	0	0	0	0	0	0	0	0	1	0
	Darker																		
	↓	↓	↓	↓	↓	↓	↓	↓	↓	↓	↓	↓	↓	↓	↓	↓	↓	↓	↓
	Brighter																		
	Blue (61)	0	0	0	0	0	0	0	0	0	0	0	0	1	1	1	1	0	1
	Blue (62)	0	0	0	0	0	0	0	0	0	0	0	0	1	1	1	1	1	0
Blue (63)	0	0	0	0	0	0	0	0	0	0	0	0	1	1	1	1	1	1	

11. Block Diagram

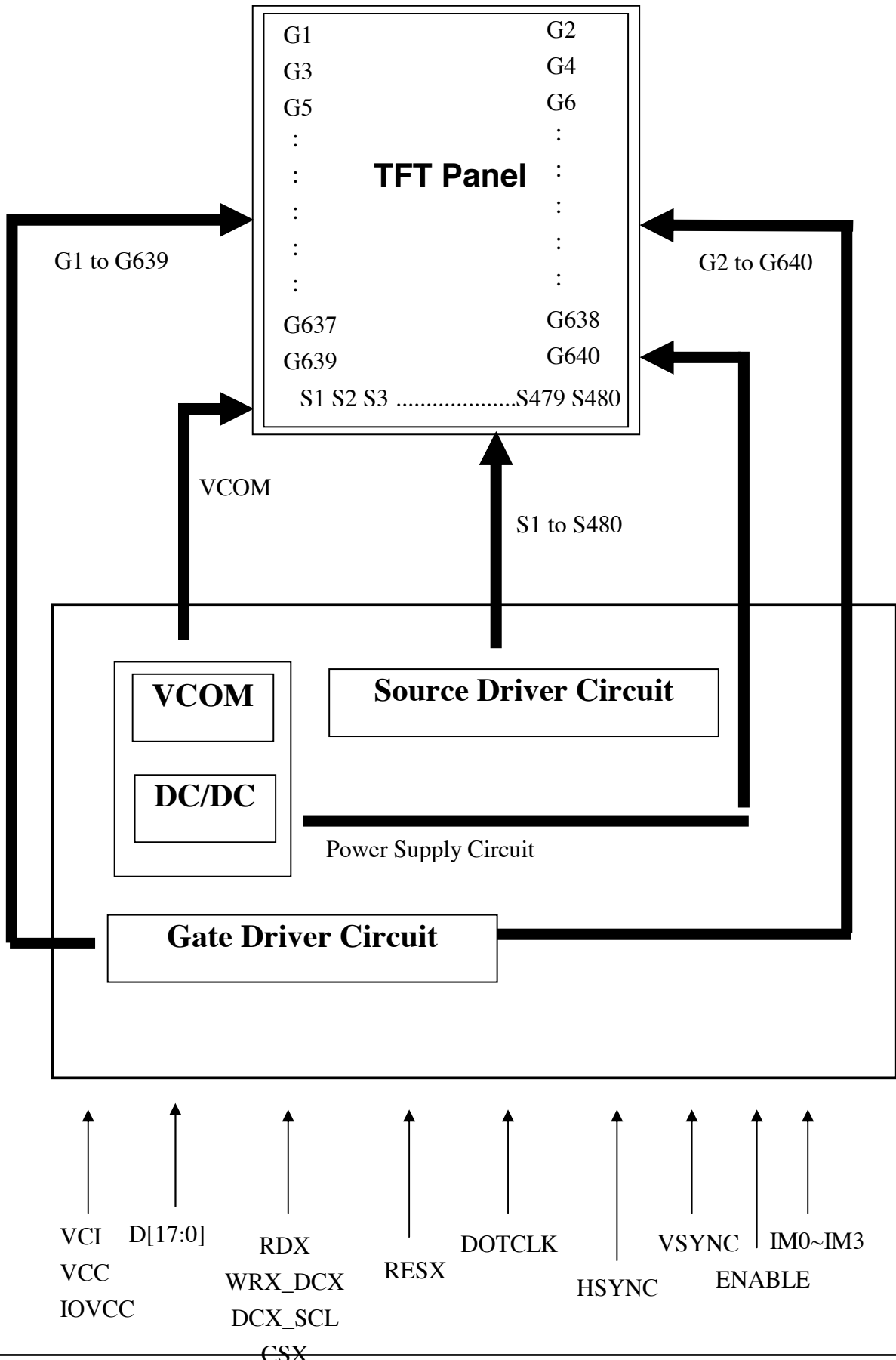

12. Interface Timing

12-1) Serial Interface Mode

12-1-1) Block Diagram

The serial bus interface can be used by setting external pin as IM [3:0] to “0101”.The figure in the following is the example of interface with microcomputer system interface.

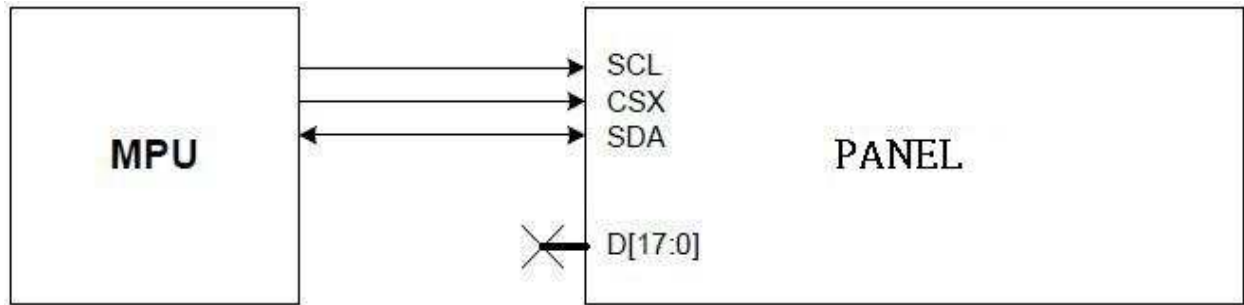

12-1-2) Data Format

The serial data packet contains a data/command select bit (D/CX) and a transmission byte. If D/CX is “low”, the transmission byte is interpreted as a command byte. If D/CX is “high”, the transmission byte is stored in the display data RAM (Memory write command), or command register as parameter.

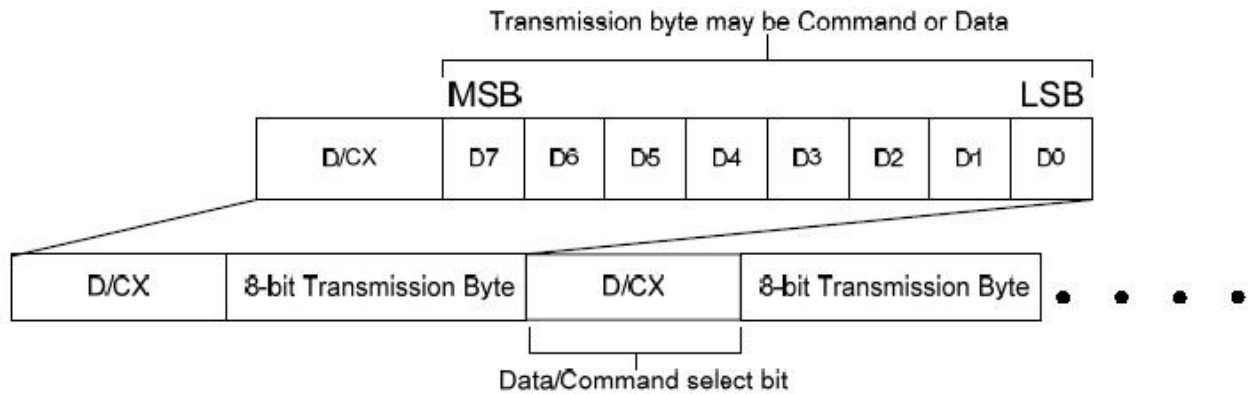

12-1-3) Serial Interface Protocol

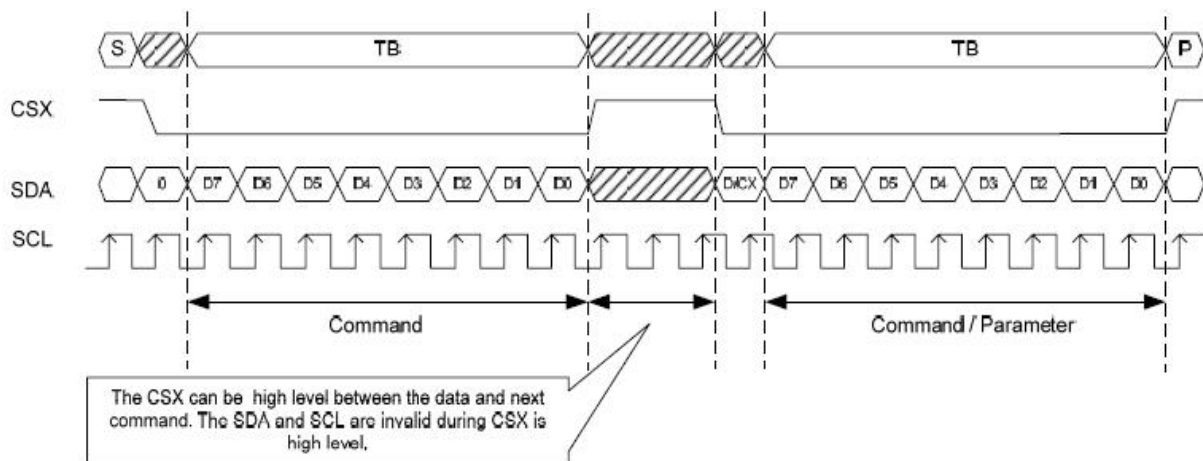

12-1-4) Timing Diagram

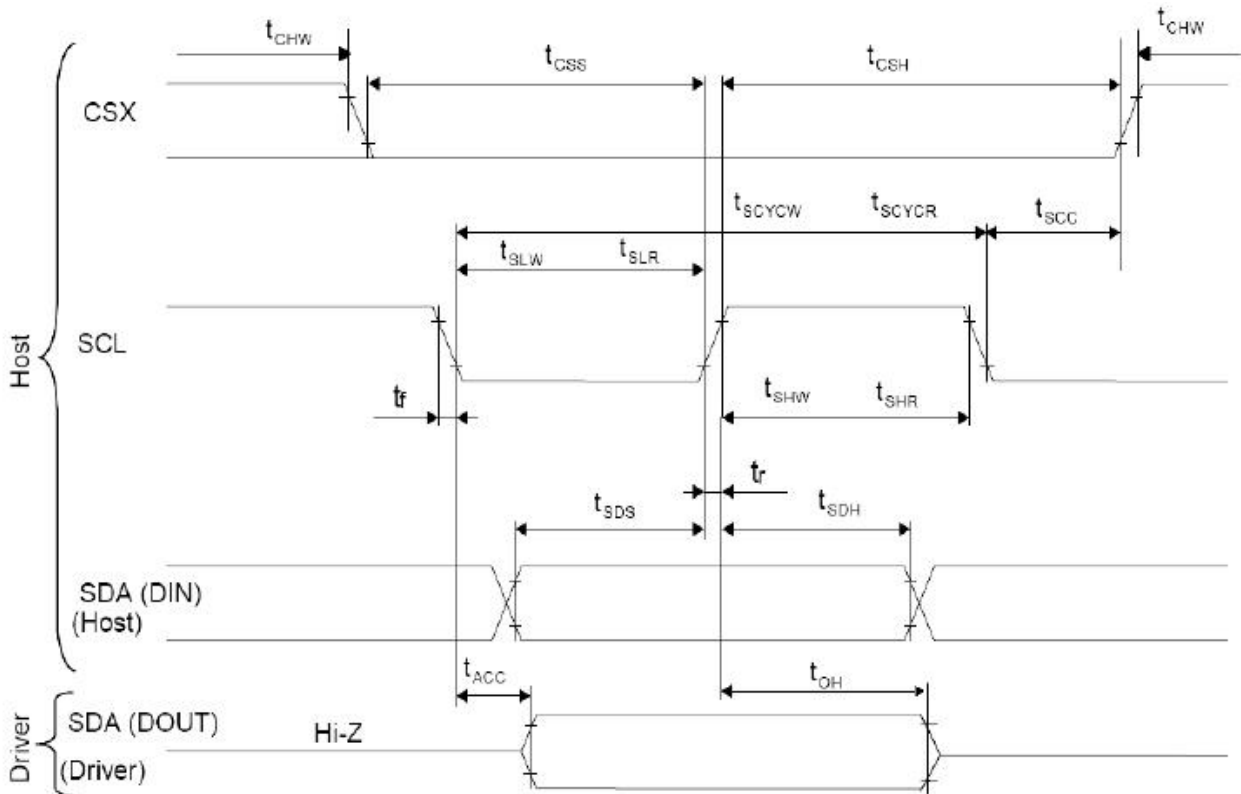

Signal	Symbol	Parameter	min	max	Unit	Description
SCL	tscycw	Serial Clock Cycle (Write)	40	-	ns	
	tshw	SCL "H" Pulse Width (Write)	15	-	ns	
	tslw	SCL "L" Pulse Width (Write)	15	-	ns	
	tscycr	Serial Clock Cycle (Read)	150	-	ns	
	tshr	SCL "H" Pulse Width (Read)	60	-	ns	
	tslr	SCL "L" Pulse Width (Read)	60	-	ns	
SDA / SDI (Input)	tsds	Data setup time (Write)	10	-	ns	
	tsdh	Data hold time (Write)	10	-	ns	
SDA / SDO (Output)	tacc	Access time (Read)	10	60	ns	
	toh	Output disable time (Read)	15	-	ns	
CSX	tsc	SCL-CSX	30	-	ns	
	tch	CSX "H" Pulse Width	60	-	ns	
	tcs	CSX-SCL Time	15	-	ns	
	tcs		15	-	ns	

12-2) 8080-Series Parallel Interface Mode

12-2-1) Block Diagram

The 8080-system 16-bit parallel bus interface can be used by setting external pin as IM [3:0] to "0010". The figure in the following is the example of interface with microcomputer system interface.

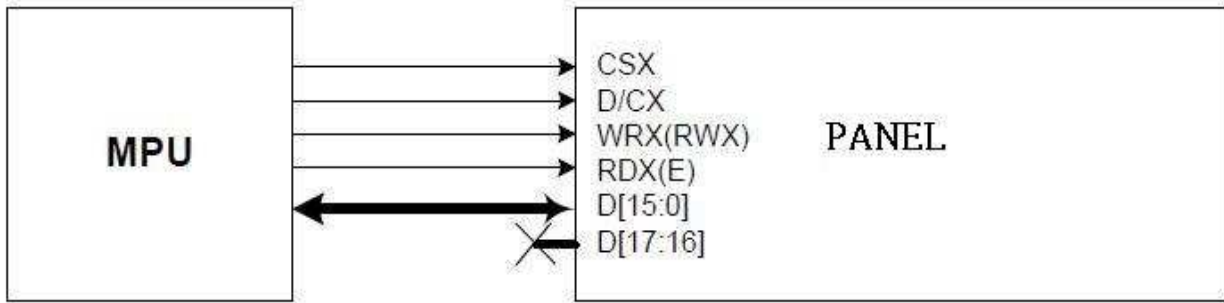

12-2-2) Timing Diagram

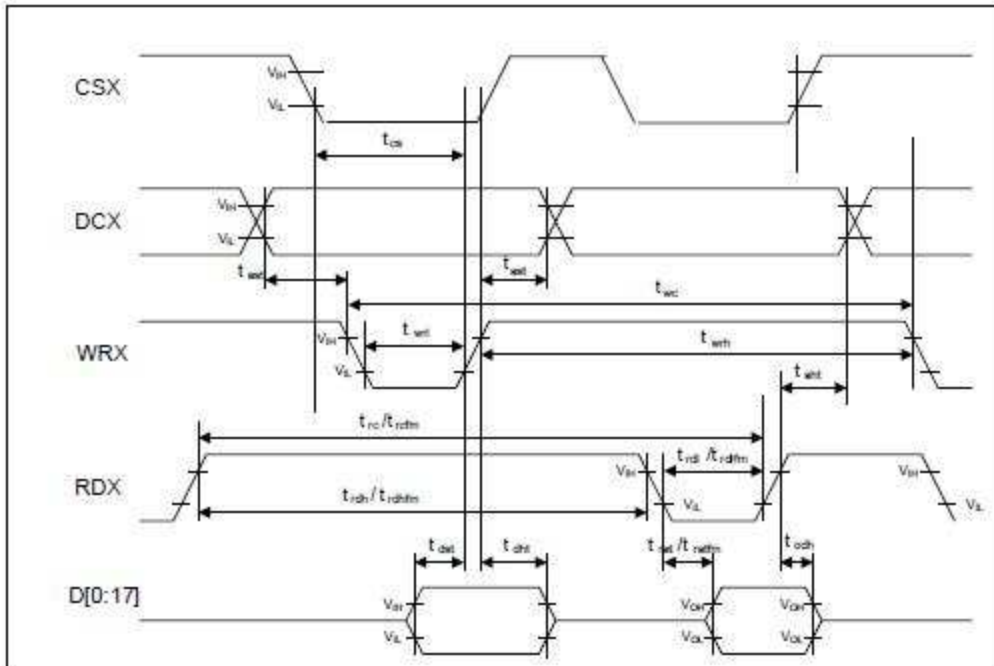

Signal	Symbol	Parameter	min	max	Unit	Description
DCX	tast	Address setup time	0	-	ns	-
	taht	Address hold time (Write/Read)	10	-	ns	-
WRX	twc	Write cycle	30	-	ns	-
	twrh	Write Control pulse H duration	15	-	ns	-
	twrl	Write Control pulse L duration	15	-	ns	-
RDX (FM)	trcfm	Read Cycle (FM)	450	-	ns	When read from Frame Memory
	trdhfm	Read Control H duration (FM)	90	-	ns	
	trdlfm	Read Control L duration (FM)	355	-	ns	
RDX (ID)	trc	Read cycle (ID)	160	-	ns	When read ID data
	trdh	Read Control pulse H duration	90	-	ns	
	trdl	Read Control pulse L duration	45	-	ns	
DB[17:0], DB[15:0], DB[8:0], DB[7:0]	tdst	Write data setup time	10	-	ns	For maximum CL=30pF For minimum CL=8pF
	tdht	Write data hold time	10	-	ns	
	trat	Read access time	-	40	ns	
	trafm	Read access time	-	340	ns	
	trodh	Read output disable time	20	80	ns	

Note: (1) Ta = -30 to 70 °C, IOVCC=1.65V to 3.3V, VCC=2.5V to 3.3V, AGND=DGND=0V

12-3) RGB Interface Mode

12-3-1) Block Diagram

This mode is operated with VSYNC, HSYNC, ENABLE, DOTCLK, DB[17:0] lines. The mode can be used by setting external pin as IM [3:0] to "0101". The figure in the following is the example of interface with microcomputer system interface.

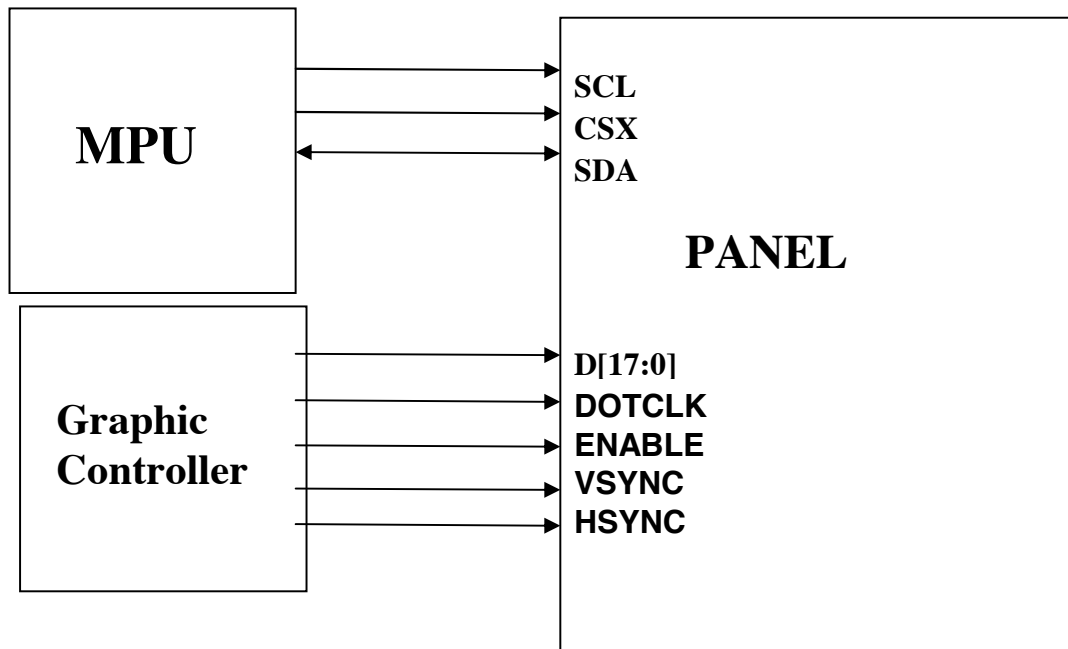

12-3-2) RGB Interface Selection

The panel supports several pixel format that can be selected by DPI [2:0] bits in “Pixel Format Set (3Ah)”command. The selection of a given interfaces are done by DPI [2:0] as show in the following table.

DPI[2:0]			RGB Interface Mode	Used Pins
1	0	1	16-bit RGB interface	VSYNC, HSYNC, ENABLE, DB[15:0]
1	1	0	18-bit RGB interface	VSYNC, HSYNC, ENABLE, DB[17:0]
Other			Setting prohibited	

The 18-bit RGB interface is selected by setting the DPI[2:0] bits to “110”. The display operation is synchronized with VSYNC, HSYNC and DOTCLK signals. The display data are transferred to the internal GRAM in synchronization with the display operation via 18-bit RGB data bus (DB[17:0]) according to the data enable signal (ENABLE).

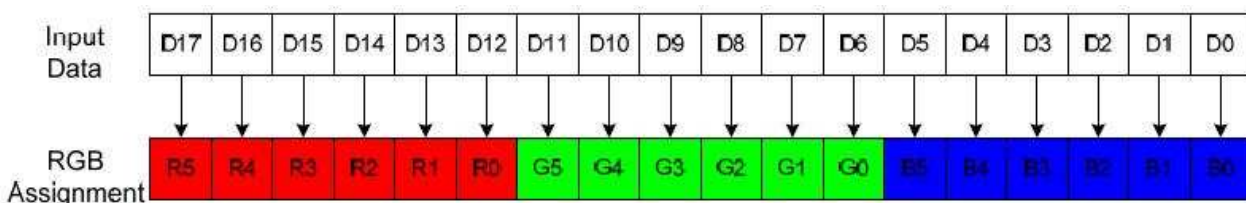

12-3-3) Timing Characteristics

Signal	Symbol	Parameter	min	max	Unit	Description
VSYNC / HSYNC	t_{SYNCS}	VSYNC/HSYNC setup time	15	-	ns	18/16-bit bus RGB interface mode
	t_{SYNCH}	VSYNC/HSYNC hold time	15	-	ns	
ENABLE	t_{ENS}	ENABLE setup time	15	-	ns	
	t_{ENH}	ENABLE hold time	15	-	ns	
DB[17:0]	t_{POS}	Data setup time	15	-	ns	
	t_{PDH}	Data hold time	15	-	ns	
DOTCLK	PWDH	DOTCLK high-level period	15	-	ns	
	PWDL	DOTCLK low-level period	15	-	ns	
	t_{CYCD}	DOTCLK cycle time	30	-	ns	
	t_{tr}, t_{trf}	DOTCLK, HSYNC, VSYNC rise/fall time	-	15	ns	

Note: $T_a = -30$ to 70 °C, $IOVCC=1.65V$ to $3.3V$, $VCC=2.5V$ to $3.3V$, $AGND=DGND=0V$

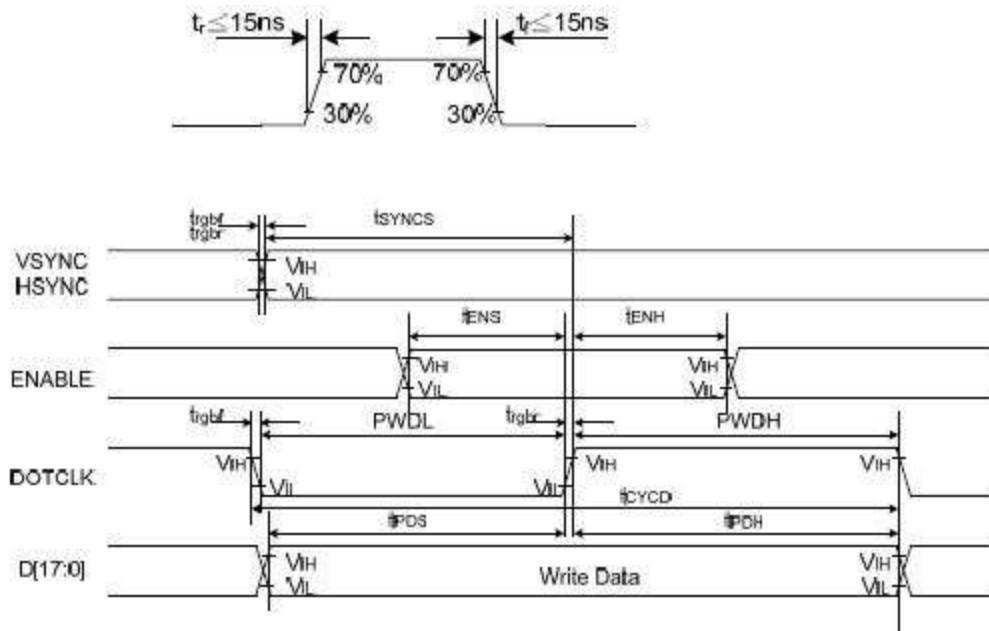

12-4) Display on Flow

```
//power
Init_Data_Comm(0x00C1);
Init_Data_Param(0x0011);
Init_Data_Param(0x004D);
Init_Data_Param(0x000D);

Init_Data_Comm(0x00EA);
Init_Data_Param(0x0000);

Init_Data_Comm(0x00F2);
Init_Data_Param(0x0040);
Init_Data_Param(0x004B);
Init_Data_Param(0x0002);
Init_Data_Param(0x002B);
Init_Data_Param(0x004A);
Init_Data_Param(0x0035);
```

//Postive Gamma Control

```
Init_Data_Param(0x0000);
Init_Data_Param(0x0010);
Init_Data_Param(0x0016);
```

```
//INTERFACE PIXEL FORMAT
```

```
Init_Data_Comm(0x003A);
Init_Data_Param(0x0066);
```

```
//Memory Access Control
```

```
Init_Data_Comm(0x0036);
Init_Data_Param(0x0008);
```

```
Init_Data_Comm(0x00FC);
Init_Data_Param(0x0000);
Init_Data_Param(0x0000);
```

```
//VCOM CONTROL 1
```

```
Init_Data_Comm(0x00C5);
Init_Data_Param(0x0000);
Init_Data_Param(0x0029);
```

```
//Display Function Control
```

```
Init_Data_Comm(0x00B6);
    Init_Data_Param(0x0032);
Init_Data_Param(0x0082);
Init_Data_Param(0x00FF);
Init_Data_Param(0x0005);
```

```
Init_Data_Comm(0x00F7);
Init_Data_Param(0x0088);
Init_Data_Param(0x0080);
Init_Data_Param(0x000D);
Init_Data_Param(0x0009);
Init_Data_Param(0x0006);
```

```
DelayX10ms(20);
```

```
Init_Data_Comm(0x00F0);
Init_Data_Param(0x0000);
```

```
Init_Data_Comm(0x00F9);
Init_Data_Param(0x0002);
```

```
//SLEEP OUT
```

```
Init_Data_Comm(0x0011);
```

```
//Display ON
```

13. Power On Sequence

13-1) Power level

6 level modes are defined they are in order of Maximum Power consumption to Minimum Power Consumption:

1. Normal Mode On (full display), Idle Mode Off, Sleep Out.
In this mode, the display is able to show maximum 262,144 colors.
2. Partial Mode On, Idle Mode Off, Sleep Out.
In this mode part of the display is used with maximum 262,144 colors.
3. Normal Mode On (full display), Idle Mode On, Sleep Out.
In this mode, the full display area is used but with 8 colors.
4. Partial Mode On, Idle Mode On, Sleep Out.
In this mode, part of the display is used but with 8 colors.
5. Sleep In Mode.
In this mode, the DC : DC converter, Internal oscillator and panel driver circuit are stopped. Only the MCU interface and memory works with IOVCC power supply. Contents of the memory are safe.
6. Power Off Mode.
In this mode, both VCI and IOVCC are removed.

Note1: Transition between modes 1-5 is controllable by MCU commands. Mode 6 is entered only when both Power supplies are removed.

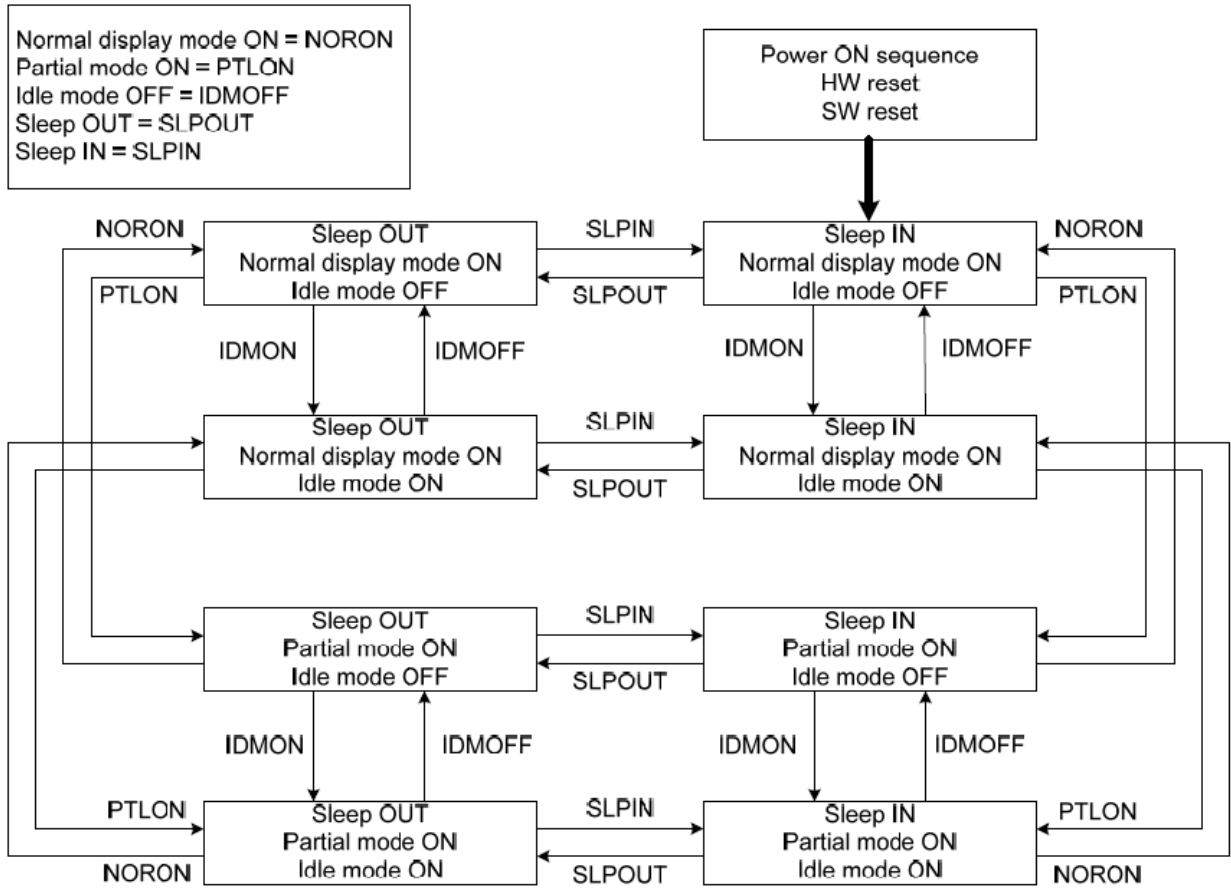

Note 1: There is not any abnormal visual effect when there is changing from one power mode to another power mode.

Note 2: There is not any limitation, which is not specified by User, when there is changing from one power mode to another power mode.

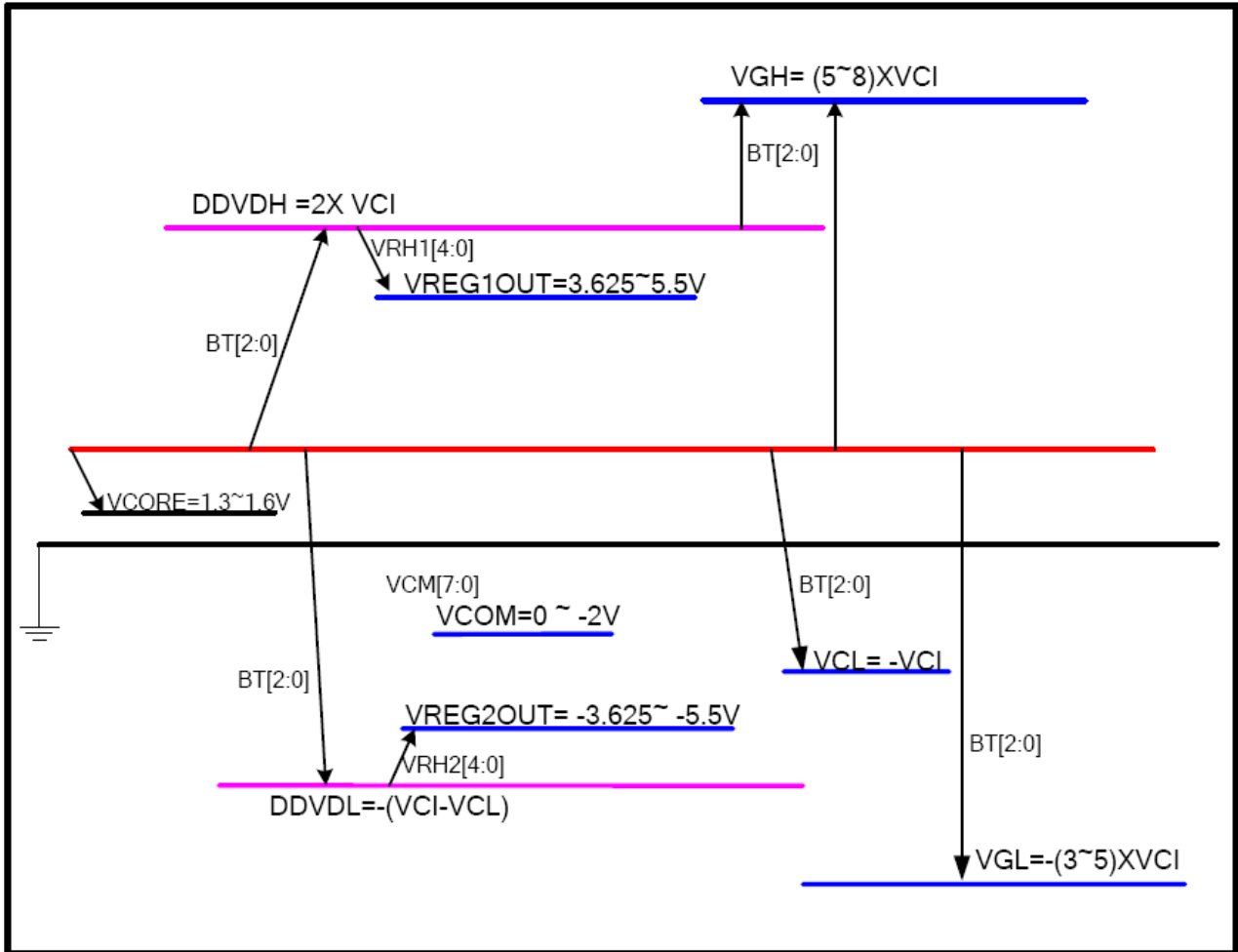

Note: The DDVDH, DDVDL, VGH, VGL and VCL output voltage levels are lower than their theoretical levels (Ideal voltage levels) due to current consumption at respective outputs.

13-2) Reset timing

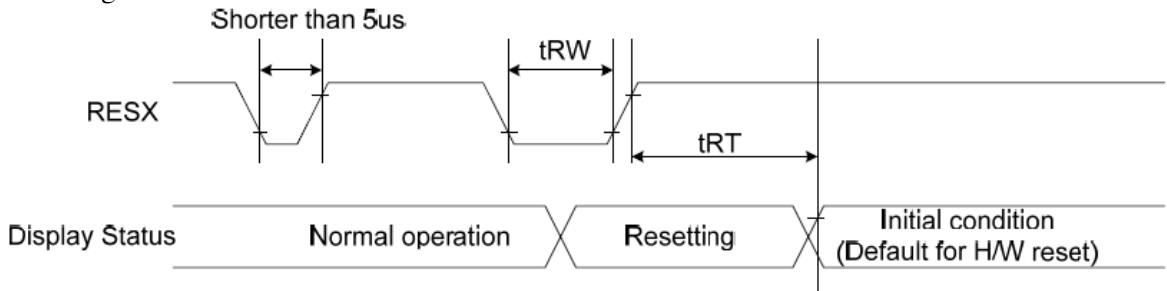

Signal	Symbol	Parameter	Min	Max	Unit
RESX	tRW	Reset pulse duration	10		uS
	tRT	Reset cancel		5 (note 1,5)	mS
				120 (note 1,6,7)	mS

Note 1: The reset cancel includes also required time for loading ID bytes, VCOM setting and other settings from EEPROM to registers. This loading is done every time when there is HW reset cancel time (tRT) within 5 ms after a rising edge of RESX.

Note 2: Spike due to an electrostatic discharge on RESX line does not cause irregular system reset according to the table below:

RESX Pulse	Action
Shorter than 5us	Reset Rejected
Longer than 9us	Reset
Between 5us and 9us	Reset starts

Note 3: During the Resetting period, the display will be blanked (The display is entering blanking sequence, which maximum time is 120 ms, when Reset Starts in Sleep Out –mode. The display remains the blank state in Sleep In -mode.) and then return to Default condition for Hardware Reset.

Note 4: Spike Rejection also applies during a valid reset pulse as shown below:

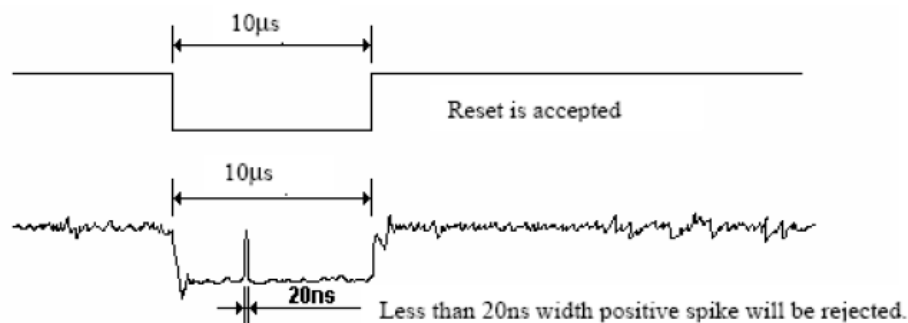

Note 5: When Reset applied during Sleep In Mode.

Note 6: When Reset applied during Sleep Out Mode.

Note7: It is necessary to wait 5msec after releasing RESX before sending commands. Also Sleep Out command cannot be sent for 120msec.

13-3) Registers

The registers that are initialized are listed as below:

Register	After Powered ON	After Hardware Reset	After Software Reset
Frame Memory	Random	Random	Random
Sleep	In	In	In
Display Mode	Normal	Normal	Normal
Display Status	Display Off	Display Off	Display Off
Idle Mode	Off	Off	Off
Column Start Address	0000 h	0000 h	0000 h
Column End Address	01DF h	01DF h	01DF h
Page Start Address	0000 h	0000 h	0000 h
Page End Address	03FF h	03FF h	03FF h
Gamma Setting	GC0	GC0	GC0
Partial Area Start	0000 h	0000 h	0000 h
Partial Area End	03FF h	03FF h	03FF h
Memory Data Access Control	00 h	00 h	00h
RDNUMED	00 h	00 h	00h
RDDPM	08 h	08 h	08 h
RDDMADCTL	00 h	00 h	00 h
RDDCOLMOD	06 h	06 h	06 h
RDDIM	00 h	00 h	00 h
RDDSM	00 h	00 h	00 h
RDDSDR	00 h	00 h	00 h
RDDISBV	00 h	00 h	00 h
RDCTRLD	00 h	00 h	00 h
RDCABC	00 h	00 h	00 h
RDCABCMB	00 h	00 h	00 h
TE Output Line	Off	Off	Off
TE Line Mode	Mode 1 (Note 3)	Mode 1 (Note 3)	Mode 1 (Note 3)

Note 1: There will be no abnormal visible effects on the display when S/W or H/W Resets are applied.

Note 2: After Powered-On Reset finishes within 10 μ s after both VCI & IOVCC are applied.

Note 3: Mode 1 means Tearing Effect Output Line consists of V-Blanking Information only.

14. Optical Characteristics

14-1) Specification:

Ta=25°C

Parameter		Symbol	Condition	MIN.	TYP.	MAX.	Unit	Remarks
Viewing Angle	Horizontal	$\theta 22 \cdot \theta 21$	CR > 10	(70)	(75)	-	deg	Note 14-1
	Vertical	$\theta 12$		(45)	(50)	-	deg	
		$\theta 11$		(45)	(50)	-	deg	
Contrast Ratio		CR	At optimized viewing angle	(400)	(450)	-	-	Note 14-2
Response time	Rise	Tr	$\theta = 0^\circ$	-	15	30	ms	Note 14-3
	Fall	Tf		-	10	20	ms	
Brightness		L	$\theta = 0^\circ / \varphi = 0$	--	400	-	cd/m ²	
Luminance Uniformity		U	-	(75)	(80)	-	%	Note 14-4
White Chromaticity		x	-	(0.26)	(0.31)	(0.36)	-	
		y	-	(0.30)	(0.35)	(0.40)	-	
Cross Talk		-	$\theta = 0^\circ$	-	-	3.5	%	Note 14-5
LED life time		-	+25°C	--	20000	-	Hr	Note 14-6

(): reference only.

All optical measurements shall be performed after backlight being turned-on for 30 mins. The optical characteristics shall be measured in dark room (ambient illumination on panel surface less than 1 Lux).

The measuring configuration shows as following figure.

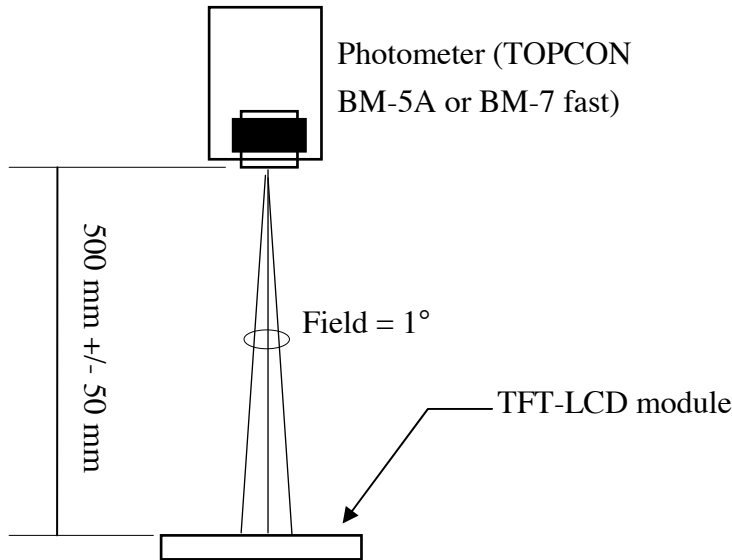

Optical characteristics measuring configuration

Topcon BM-5A or BM-7 fast luminance meter 1° field of view is used in the testing.

Note 14-1: The definitions of viewing angles are as follow

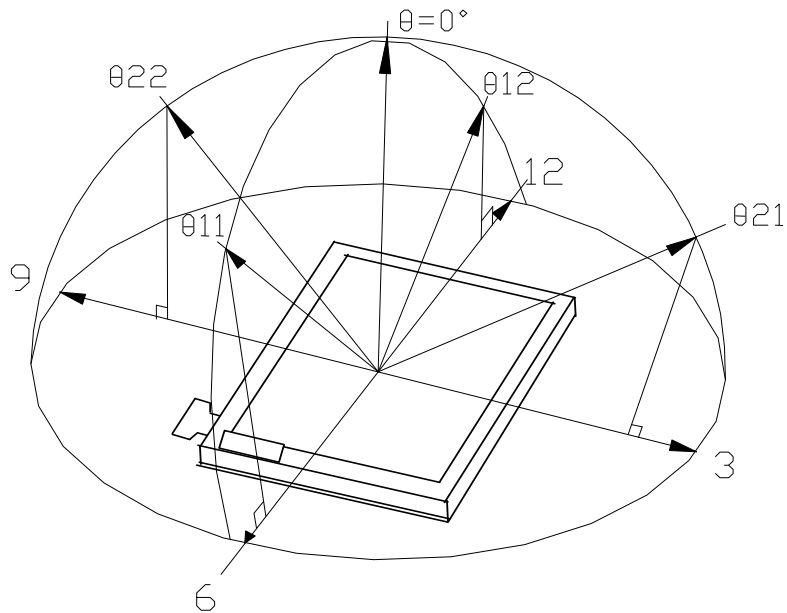

Note 14-2: The definition of contrast ratio $CR = \frac{\text{Luminance at White pattern}}{\text{Luminance at black pattern}}$

Note 14-3: Definition of Response Time T_r and T_f :

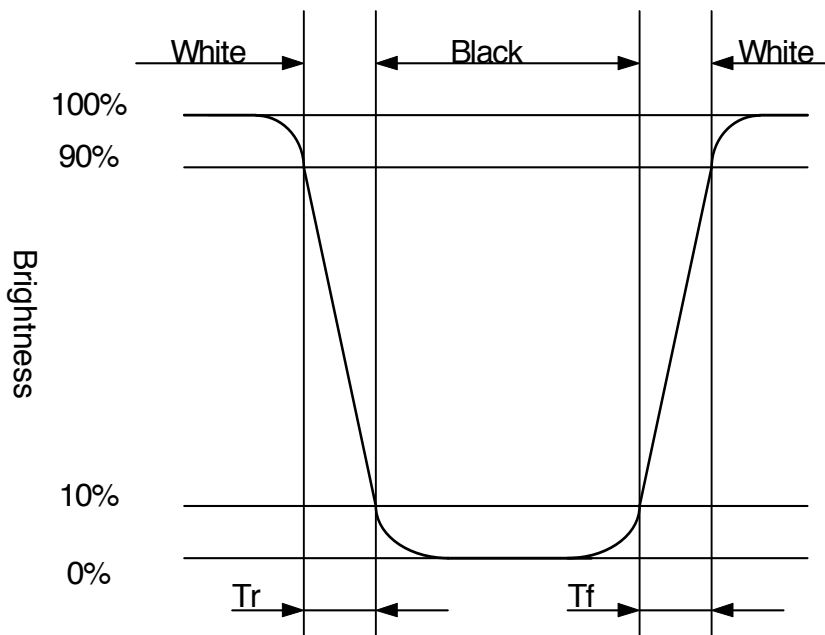

Note 14-4: The uniformity of LCD is defined as

$$U = \frac{\text{The Minimum Brightness of the 9 testing Points}}{\text{The Maximum Brightness of the 9 testing Points}}$$

The Maximum Brightness of the 9 testing Points

Luminance meter: BM-5A or BM-7 fast (TOPCON)

Measurement distance: 500 mm +/- 50 mm

Ambient illumination: < 1 Lux

Measuring direction: Perpendicular to the surface of module

The test pattern is white (Gray Level 63).

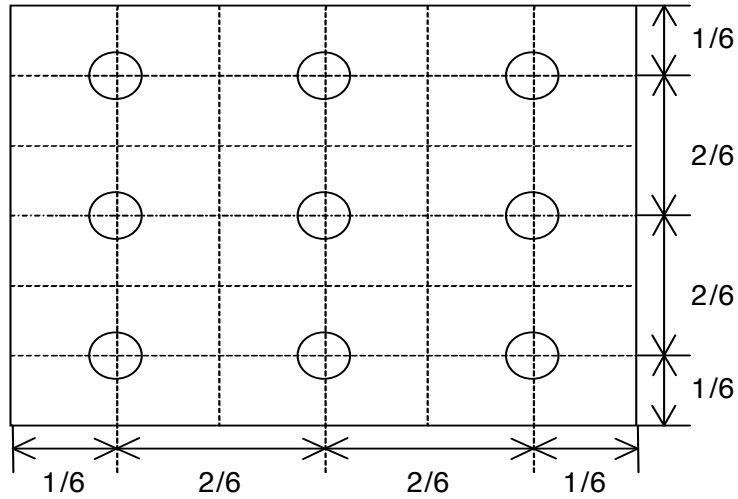

Note 14-5: Cross Talk (CTK) = $\frac{|YA-YB|}{YA} \times 100\%$

YA: Brightness of Pattern A

YB: Brightness of Pattern B

Luminance meter: BM-5A or BM-7 fast (TOPCON)

Measurement distance: 500 mm +/- 50 mm

Ambient illumination: < 1 Lux

Measuring direction: Perpendicular to the surface of module

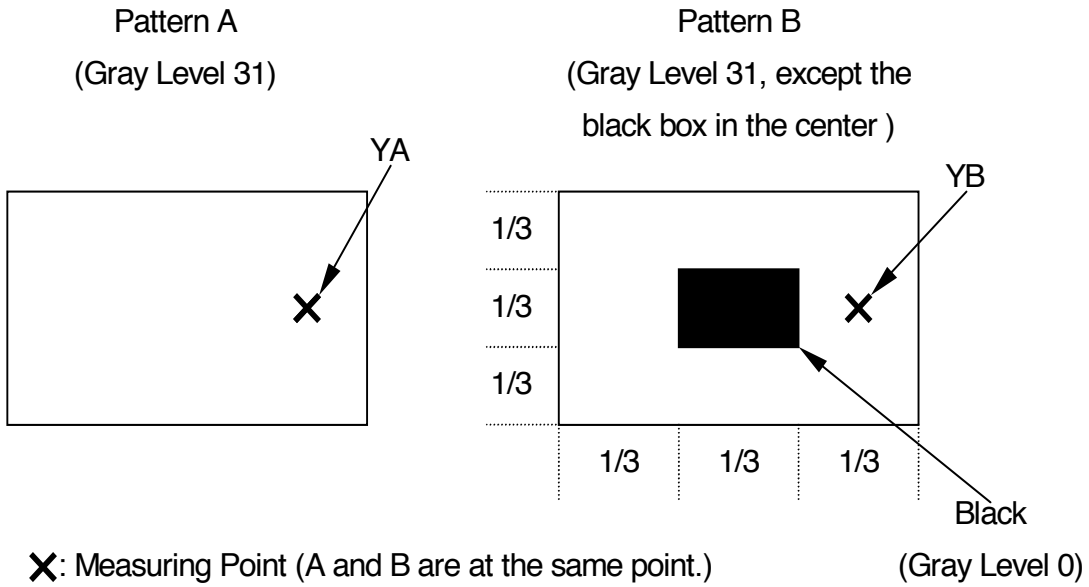

Note 14-6: The “LED Life time “ is defined as the module brightness decrease to 50% original Brightness that the ambient temperature is 25°C and $I_{LED} = 60\text{mA}$

15. Handling Cautions

15-1) Mounting of module

- a) Please power off the module when you connect the input/output connector.
- b) Polarizer which is made of soft material and susceptible to flaw must be handled carefully.
- c) Protective film (Laminator) is applied on surface to protect it against scratches and dirt. It is recommended to peel off the laminator before use and taking care of static electricity.
- d) Please following the tear off direction as figure 14-1 to remove the protective film as slowly as possible, so that electrostatic charge can be minimized.

15-2) Precautions in mounting

- a) When metal part of the TFT-LCD module (shielding lid and rear case) is soiled, wipe it with soft dry cloth.
- b) Wipe off water drops or finger grease immediately. Long contact with water may cause discoloration or spots.
- c) TFT-LCD module uses glass which breaks or cracks easily if dropped or bumped on hard surface. Please handle with care.
- d) Since CMOS LSI is used in the module. So take care of static electricity and earth yourself when handling.

15-3) Adjusting module

- a) Adjusting volumes on the rear face of the module have been set optimally before shipment.
- b) Therefore, do not change any adjusted values. If adjusted values are changed, the specifications described may not be satisfied.

15-4) Others

- a) Do not expose the module to direct sunlight or intensive ultraviolet rays for many hours.
- b) Store the module at a room temperature place.
- c) The voltage of beginning electric discharge may over the normal voltage because of leakage current from approach conductor by to draw lump read lead line around.
- d) If LCD panel breaks, it is possibly that the liquid crystal escapes from the panel. Avoid putting it into eyes or mouth. When liquid crystal sticks on hands, clothes or feet. Wash it out immediately with soap.
- e) Observe all other precautionary requirements in handling general electronic components.
- f) Please adjust the voltage of common electrode as material of attachment by 1 module.

15-5) Polarizer mark

The polarizer mark is to describe the direction of wide view angle film how to match up with the rubbing direction.

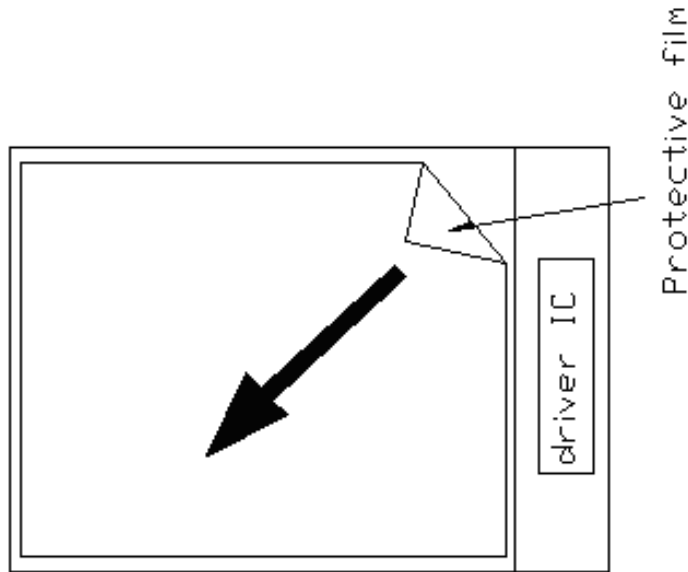

Figure 15-1 the way to peel off protective film

16. Reliability Test

No	Test Item	Test Condition
1	High Temperature Storage Test	Ta = +80°C, 240 hrs
2	Low Temperature Storage Test	Ta = -30°C, 240 hrs
3	High Temperature Operation Test	Ta = +70°C, 240 hrs
4	Low Temperature Operation Test	Ta = -30°C, 240 hrs
5	High Temperature & High Humidity Operation Test	Ta = +60°C, 90%RH, 240 hrs (No Condensation)
6	Thermal Cycling Test (non-operating)	-30°C → +70°C, 200 Cycles 30min 30min
7	Vibration Test (non-operating)	Frequency : 10 ~ 55 Hz Amplitude : 1 mm Sweep time: 11 mins Test Period: 6 Cycles for each direction of X, Y, Z
8	Shock Test (non-operating)	100G, 6ms Direction: ±X, ±Y, ±Z Cycle: 3 times
9	Electrostatic Discharge Test (non-operating)	200pF, 0Ω ±200V 1 time / each terminal

[Criteria]

1. In the standard conditions, there is not display function NG issue occurred. (including :line defect ,no image) All the cosmetic specification is judged before the reliability stress

17. Packing Diagram
TBD