

Version : 1.0

TECHNICAL SPECIFICATION
MODEL NO : PD104SLA

The content of this information is subject to be changed without notice.
Please contact PVI or its agent for further information.

Customer's Confirmation

Customer _____

Date _____

By _____

PVI's Confirmation

Confirmed By _____

Prepared By _____

Revision History

Rev.	Issued Date	Eng.	Revised Content
1.0	Aug.08 , 2007	李穎銘	New

TECHNICAL SPECIFICATION

CONTENTS

<i>NO.</i>	<i>ITEM</i>	<i>PAGE</i>
-	Cover	1
-	Revision History	2
-	Contents	3
1	Application	4
2	Features	4
3	Mechanical Specifications	4
4	Mechanical Drawing of TFT-LCD module	5
5	Input Terminals	7
6	Absolute Maximum Ratings	9
7	Electrical Characteristics	9
8	Power On Sequence	17
9	Optical Characteristics	18
10	Handling Cautions	21
11	Reliability Test	22
12	Block Diagram	23
13	Packing	24

1. Application

This data sheet applies to a color TFT LCD module, PD104SLA.

PD104SLA module applies to OA product, car TV (must use Analog to Digital drive board), which require high quality flat panel display. If you must use in high reliability environment can't over reliability test condition

Prime View assume no responsibility for any damage resulting from the use of the device which dose not comply with the instructions and the precautions in these specification sheet.

2. Features

- . Amorphous silicon TFT LCD panel with back-light unit
- . Pixel in stripe configuration
- . Slim and compact, designed for O/A application
- . Display Colors : 262,144 colors
- . +3.3V DC supply voltage for TFT LCD panel driving
- . Backlight driving DC/AC inverter not included in this module
- . Wide Viewing Angle

3. Mechanical Specifications

Parameter	Specifications	Unit
Screen Size	26.4(diagonal)	cm
	10.4 (diagonal)	inch
Display Format	800x(R, G, B)x600	dot
Display Colors	262,144	
Active Area	211.2(H)x158.4 (V)	mm
Pixel Pitch	0.264 (H)x0.264 (V)	mm
Pixel Configuration	Stripe	
Outline Dimension	236.0 (w)x174.3(H)x5.6(typ.) (D)	mm
Weight	320±15	g
Back-light	CCFL,1 tube	
Surface treatment	Anti-glare and WV film	
Display mode	Normally white	
Gray scale inversion direction	6 o'clock [ref to Page 18 viewing angle]	

4. Mechanical Drawing of TFT-LCD Module

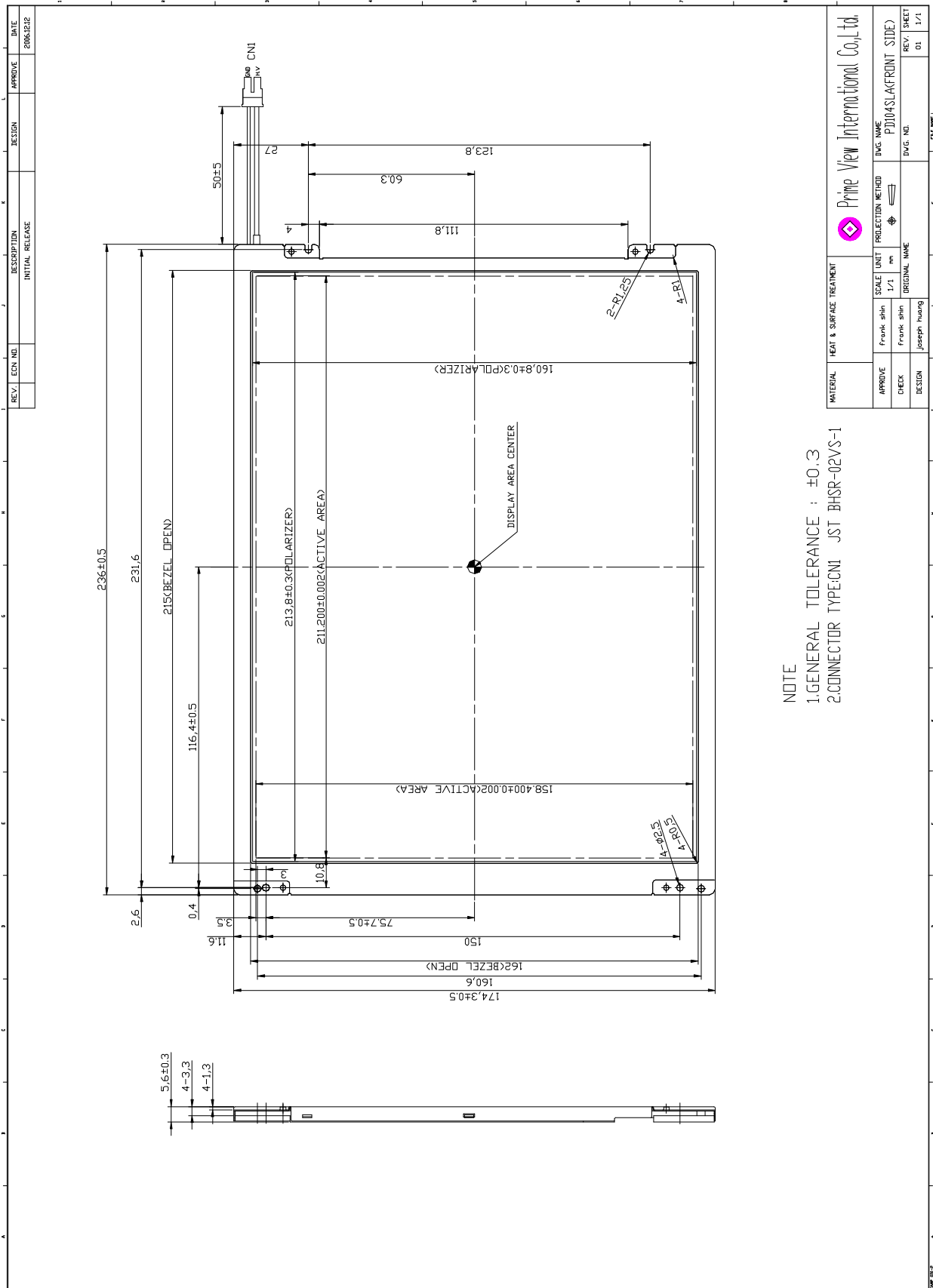

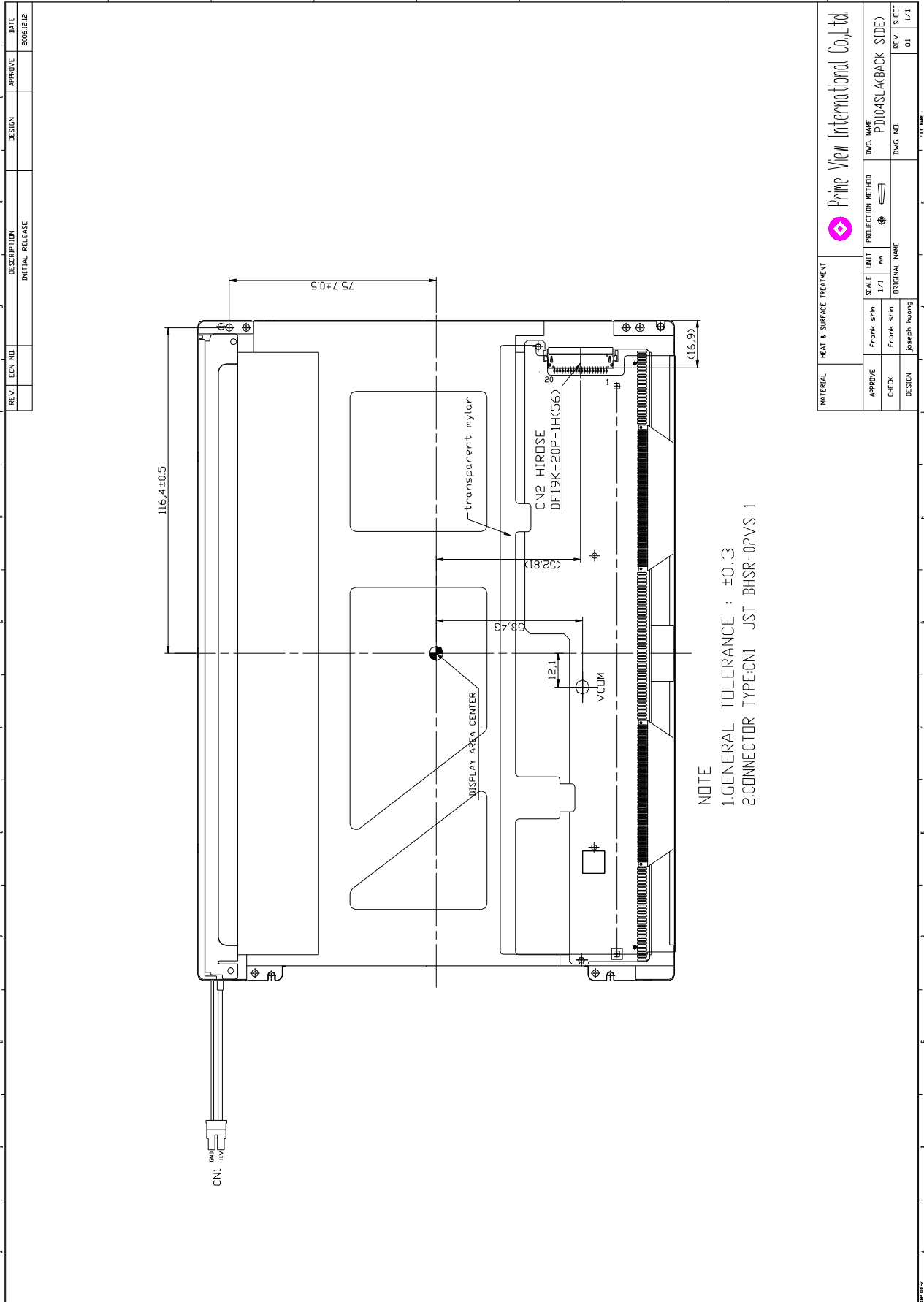

REV.	ECN NO.	DESCRIPTION	DATE
		INITIAL RELEASE	20061212

DESIGN	APPROVE

MATERIAL	HAAT & SURFACE TREATMENT	PRIME VIEW INTERNATIONAL CO., LTD.
APPROVE	SCALE	DWG NAME
Frank shin	1/1	PD104SLA(BACK SIDE)
CHECK	UNIT	DWG NO.
Frank shin	mm	
DESIGN	PROJECTION METHOD	REV.
Joseph Huang	1st	01
	ORIGINAL NAME	SHEET
		1/1

5. Input Terminals

5-1) TFT-LCD Panel Driving

Connector type: HIROSE DF19K-20P-1H (56)

Pin No.	Symbol	Function	Remark
1	V _{DD}	+3.3V Power Supply	
2	V _{DD}	+3.3V Power Supply	
3	GND	Ground	
4	GND	Ground	
5	INO-	LVDS receiver signal channel 0	
6	INO+	LVDS receiver signal channel 0	
7	GND	Ground	
8	IN1-	LVDS receiver signal channel 1	
9	IN1+	LVDS receiver signal channel 1	
10	GND	Ground	
11	IN2-	LVDS receiver signal channel 2	
12	IN2+	LVDS receiver signal channel 2	
13	GND	Ground	
14	CLK-	LVDS receiver signal clock	
15	CLK+	LVDS receiver signal clock	
16	GND	Ground	
17	NC	No connection	
18	NC	No connection	
19	GND	Ground	
20	GND	Ground	

Recommended Transmitter (THC63LVDM63A Thine) to PD104SLA interface Assignment:

Input terminal of THC63LVDM63A		Graphic controller output signal		Output signal symbol	ToPD104SLA interface terminal(Symbol)
Symbol	No.	Symbol	Function		
TIN0	44	R0	Red pixel data (LSB)	} Tout0- } Tout0+	No.5 : IN0- No.6 : IN0+
TIN1	45	R1	Red pixel data		
TIN2	47	R2	Red pixel data		
TIN3	48	R3	Red pixel data		
TIN4	1	R4	Red pixel data		
TIN5	3	R5	Red pixel data(MSB)		
TIN6	4	G0	Green pixel data (LSB)	} Tout1- } Tout1+	No.7 : IN1- No.8 : IN1+
TIN7	6	G1	Green pixel data		
TIN8	7	G2	Green pixel data		
TIN9	9	G3	Green pixel data		
TIN10	10	G4	Green pixel data		
TIN11	12	G5	Green pixel data(MSB)		
TIN12	13	B0	Blue pixel data(LSB)	} Tout2- } Tout2+	No.9 : IN2- No.10 : IN2+
TIN13	15	B1	Blue pixel data		
TIN14	16	B2	Blue pixel data		
TIN15	18	B3	Blue pixel data		
TIN16	19	B4	Blue pixel data		
TIN17	20	B5	Blue pixel data(MSB)		
TIN18	22	HSYNC	Horizontal sync signal	} Tout2+	No.10 : IN2+
TIN19	23	VSYNC	Vertical sync signal		
TIN20	25	DENB	Compound Synchronization signal		
TCLK in	26	CLK	Data sampling clock	TCLK out- TCLK out+	No.11 : CLK - No.12 : CLK +

LVDS Interface Block Diagram

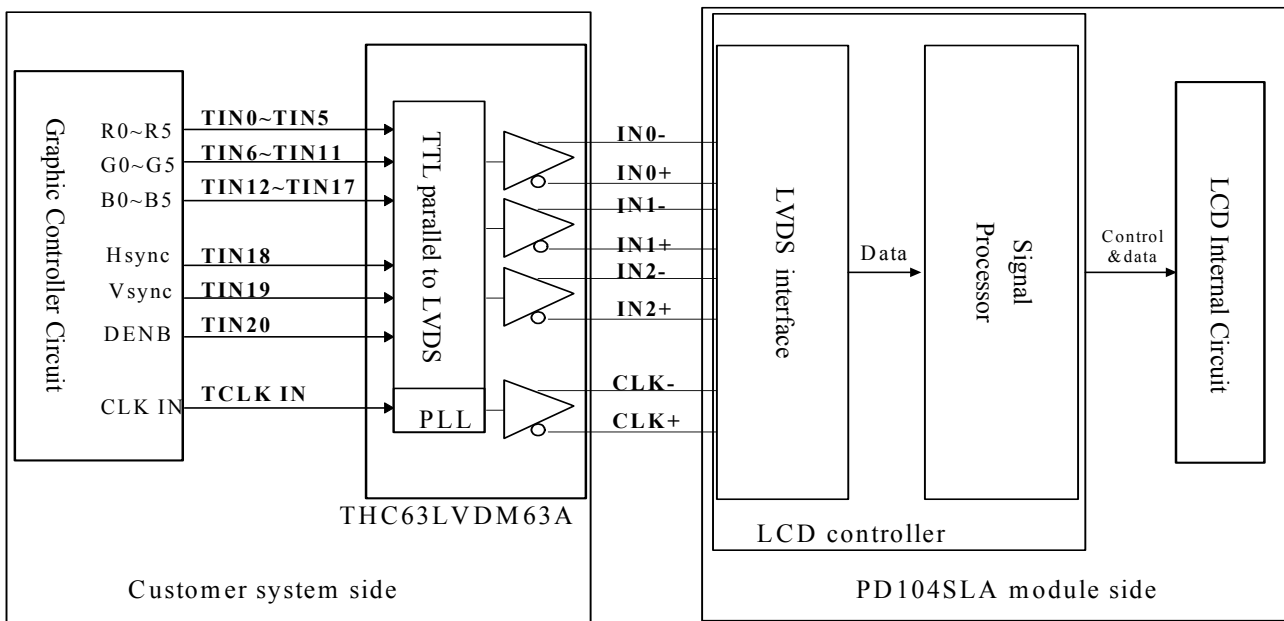

5-2) Backlight driving

Connector type : "BHSR-02VS-1" of Japan Solderless Terminal MFG Co. LTD

PIN NO.	Symbol	Description	Remark
1	VL1	Input Voltage(High)	
2	VL2	Input Voltage(Low)	

6. Absolute Maximum Ratings:

GND=0V, Ta=25°C

Parameters	Symbol	MIN.	MAX.	Unit	Remark
Supply Voltage	V _{DD}	-0.3	+4.0	V	
Input Signals Voltage	V _{IN}	-0.3	VDD+0.3	V	Note 6-1
Backlight Driving Voltage	V _L	-	2000	V	
Backlight Driving Frequency	F _L	40	80	KHz	

Note 6-1: LVDS signal.

7. Electrical Characteristics

7-1) Recommended Operating Conditions:

GND = 0V , Ta = 25°C

Item	Symbol	Min.	Typ.	Max.	Unit	Remark
Supply Voltage	V _{DD}	3.0	3.3	3.6	V	
Current Dissipation	I _{DD}	-	190	380	mA	Note 7-1
LVDS Differential input high threshold	V _{TH}	-	-	100	mV	Note 7-2
LVDS Differential input low threshold	V _{TL}	-100	-	-		
Lamp Current	I _{FL}	3.0	5.0	7.0	mA	Note 7-3 Note 7-5
Lamp Voltage	V _L	468	520	572	V _{rms}	Note 7-3 I _L =5mA
Starting Voltage (25°C) (Reference Value)	V _s	-	-	890	V _{rms}	Note 7-4
Starting Voltage (0°C) (Reference Value)	V _s	-	-	1100	V _{rms}	
Starting Voltage (-20°C) (Reference Value)	V _s	-	-	1300	V _{rms}	
Lamp Driving Frequency	F _L	40	60	80	KHz	
Lamp power consumption	-	2.34	2.6	2.86	W	Note 7-5 I _L =5mA

Note 7-1 : To test the current dissipation of VDD, using the “color bars” testing pattern shown as below

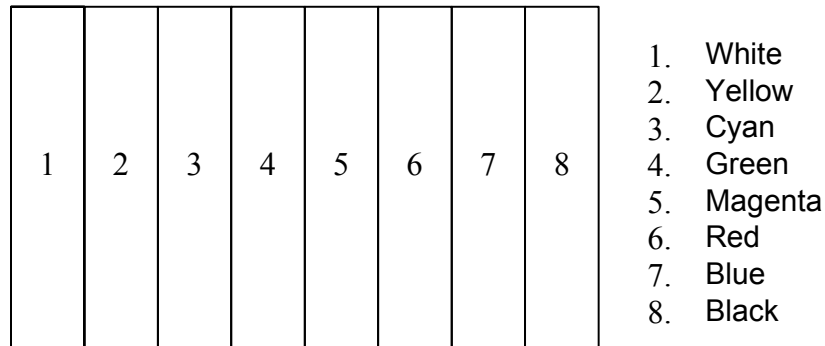

Idd current dissipation testing pattern

Note 7-2 : Please refers to THC63LVDF63A specification by THINE Corporation. This LCD module conforms to LVDS standard.

Note 7-3 : The back-light driving waveform should be as closed to sine-wave as possible. In order to satisfy the quality of B/L, no matter use what kind of inverter, the output lamp current must between Min. and Max. to avoid the abnormal display image caused by B/L.

Note 7-4 : The” Max of starting voltage ” means the minimum voltage of inverter to turn on the CCFL, and it should be applied to the lamp for more than 1 second to start up. Otherwise the lamp may not be turned on.

Note 7-5 : Lamp current is measured with current meter for high frequency as shown below

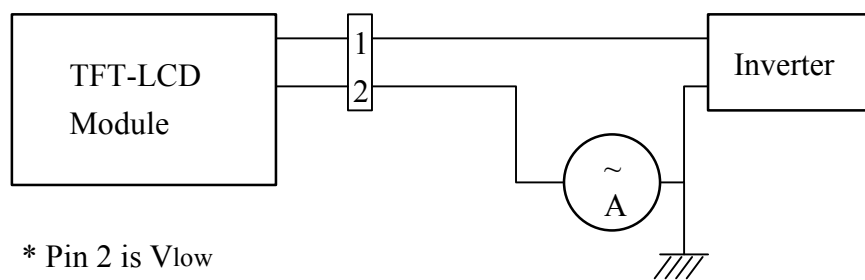

* Pin 2 is Vlow
 ** Current meter :
 Yokogawa 2016-01

Lamp current dissipation testing configuration

7-2) Input signal timing :

DENB pin have high priority than SYNC mode (HSVC+VSYNC). When IC only use SYNC pin, DENB pin have to connect to ground.

(A) Timing Specifications (DENB Mode):

Item	Symbol	Min.	Typ.	Max.	Unit	Remark
Frame Cycling Period	t1	604 X t3	628X t3	800 X t3	-	
		14	16.58	20	ms	
Vertical Display Period	t2	600 X t3	600 X t3	600 X t3	-	
Horizontal Scanning Time	t3	920 X t5	1056 X t5	1064 X t5	-	
		24	26.4	33	μs	
Horizontal Display Period	t4	800 X t5	800 X t5	800 X t5	-	
Clock Cycle	t5	20	25.0	31.25	ns	
Clock High Level Time	t6	9.0	-	-	ns	
Clock Low Level Time	t7	9.0	-	-	ns	
Hold time	t8	4.0	-	-	ns	
Set-up time	t9	5.0	-	-	ns	

(B). Timing Specifications (SYNC Mode)

	Item	Symbol	Min.	Typ.	Max.	Unit	Remark	
HSYNC	Period	Hp	24	26.4	33	us		
			920	1056	1064	tc		
	Display period	Hdp	800	800	800	tc		
	Pulse width	Hpw	12	128	202	tc		
	Back-porch	Hbp	12	86	202	tc		
	Front-porch	Hfp	42	42	42	tc		
	Hpw+Hbp			214	214	214	tc	
	Hsync-CLK	Hhc	10	-	Tc-10	ns		
Vsync-Hsync	Hvh	0	0	200	tc			
VSYNC	Period (Frame cycling period)	Vp	14	16.58	20	ms	Note 1	
			604	628	800	Hp		
	Display period	Vdp	600	600	600	Hp		
	Pulse width	Vpw	2	4	27	Hp		
	Back-porch	Vbp	0	23	25	Hp		
	Front-porch	Vfp	1	1	1	Hp		
	Vpw+Vbp			27	27	27	Hp	

Note 1 : Frame cycling period is optimum in 16.58ms.(60Hz)

(C)Timing Chart:

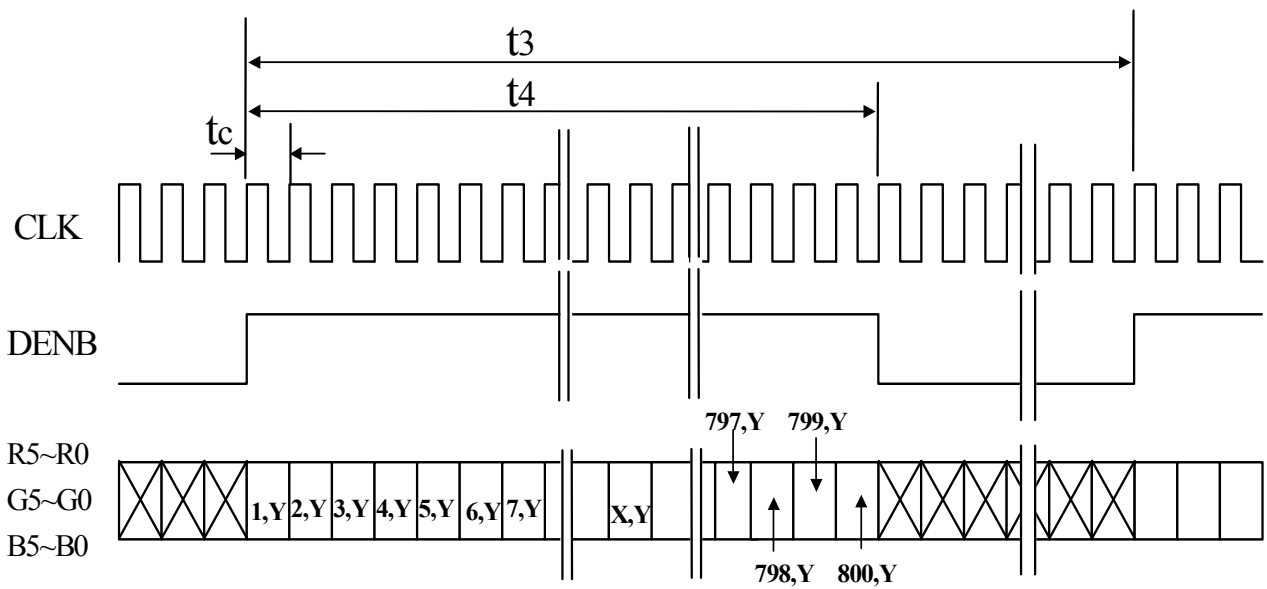
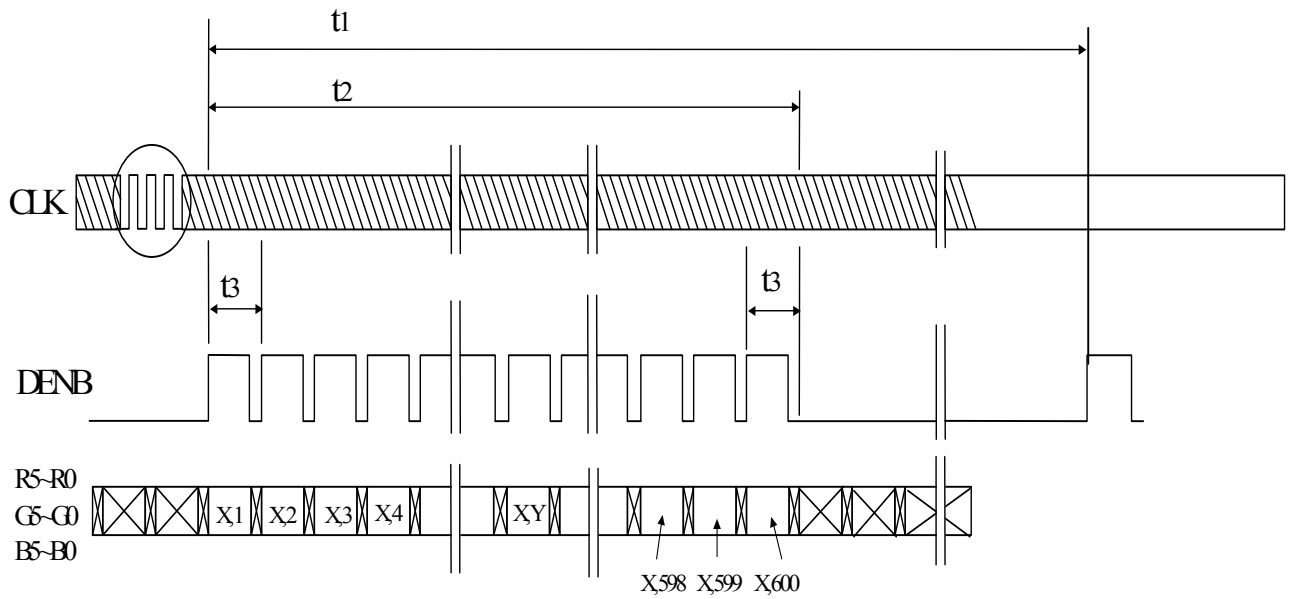

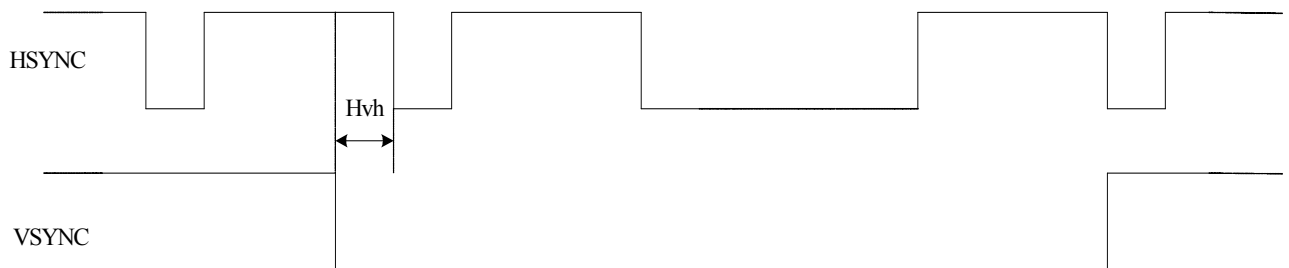
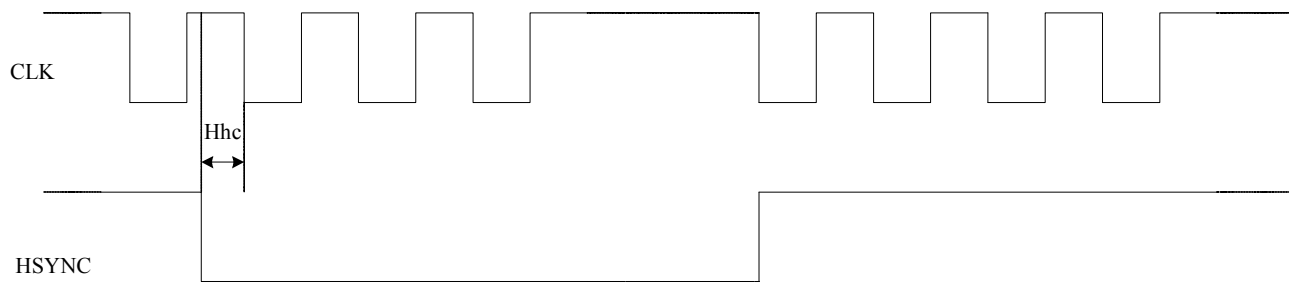
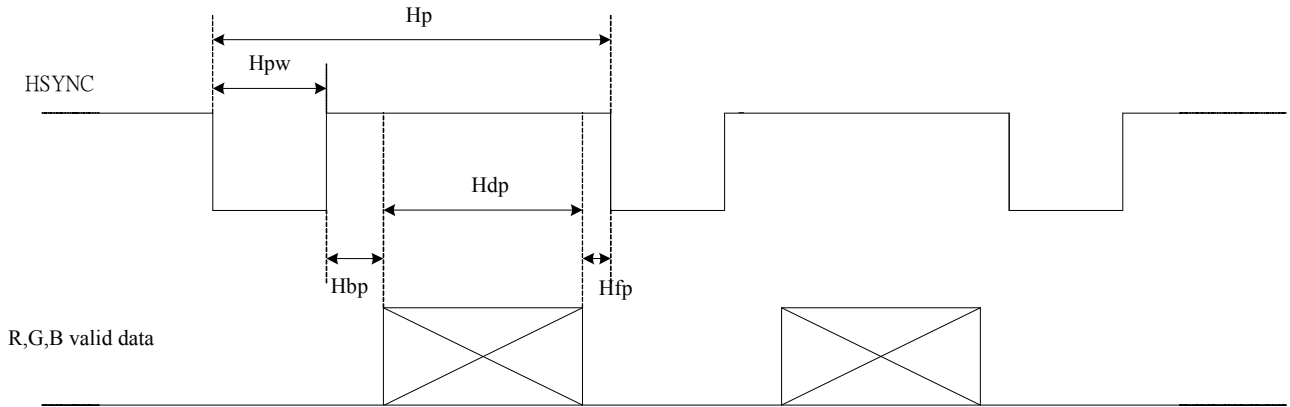

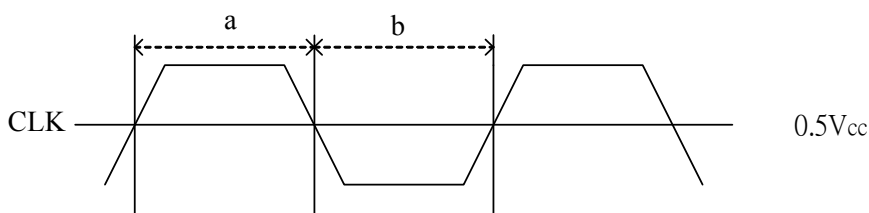
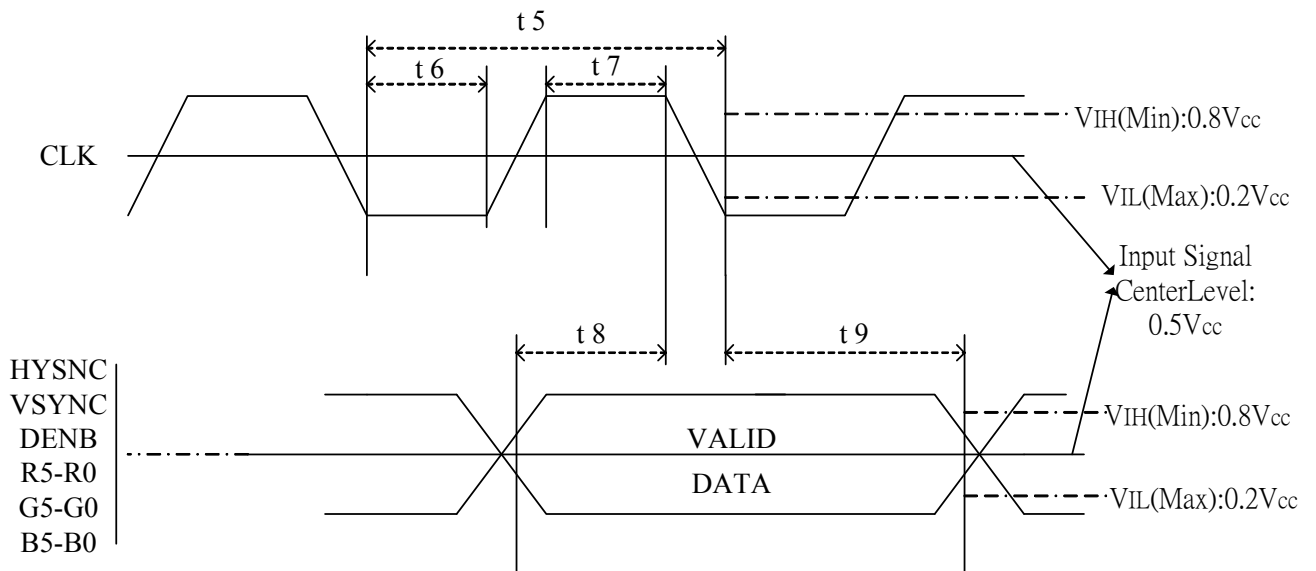
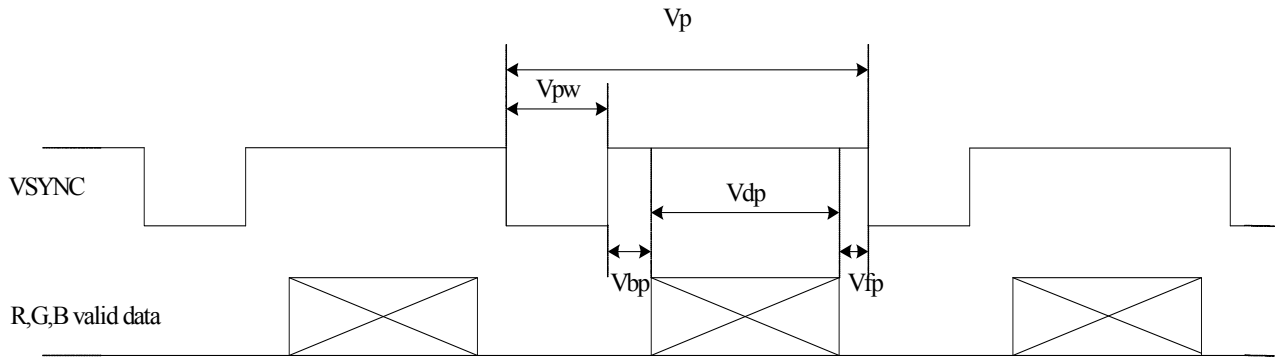

Duty (a , b) : $50 \pm 10\%$

7-3) Display Color and Gray Scale Reference

Color		Input Color Data																	
		Red						Green						Blue					
		R5	R4	R3	R2	R1	R0	G5	G4	G3	G2	G1	G0	B5	B4	B3	B2	B1	B0
Basic Colors	Black	0	0	0	0	0	0	0	0	0	0	0	0	0	0	0	0	0	0
	Red (63)	1	1	1	1	1	1	0	0	0	0	0	0	0	0	0	0	0	0
	Green (63)	0	0	0	0	0	0	1	1	1	1	1	1	0	0	0	0	0	0
	Blue (63)	0	0	0	0	0	0	0	0	0	0	0	0	1	1	1	1	1	1
	Cyan	0	0	0	0	0	0	1	1	1	1	1	1	1	1	1	1	1	1
	Magenta	1	1	1	1	1	1	0	0	0	0	0	0	1	1	1	1	1	1
	Yellow	1	1	1	1	1	1	1	1	1	1	1	1	0	0	0	0	0	0
	White	1	1	1	1	1	1	1	1	1	1	1	1	1	1	1	1	1	1
Red	Red (00)	0	0	0	0	0	0	0	0	0	0	0	0	0	0	0	0	0	0
	Red (01)	0	0	0	0	0	1	0	0	0	0	0	0	0	0	0	0	0	0
	Red (02)	0	0	0	0	1	0	0	0	0	0	0	0	0	0	0	0	0	0
	Darker																		
	↓	↓	↓	↓	↓	↓	↓	↓	↓	↓	↓	↓	↓	↓	↓	↓	↓	↓	↓
	Brighter																		
	Red (61)	1	1	1	1	0	1	0	0	0	0	0	0	0	0	0	0	0	0
	Red (62)	1	1	1	1	1	0	0	0	0	0	0	0	0	0	0	0	0	0
Red (63)	1	1	1	1	1	1	0	0	0	0	0	0	0	0	0	0	0	0	
Green	Green (00)	0	0	0	0	0	0	0	0	0	0	0	0	0	0	0	0	0	0
	Green (01)	0	0	0	0	0	0	0	0	0	0	0	1	0	0	0	0	0	0
	Green (02)	0	0	0	0	0	0	0	0	0	0	1	0	0	0	0	0	0	0
	Darker																		
	↓	↓	↓	↓	↓	↓	↓	↓	↓	↓	↓	↓	↓	↓	↓	↓	↓	↓	↓
	Brighter																		
	Green (61)	0	0	0	0	0	0	1	1	1	1	0	1	0	0	0	0	0	0
	Green (62)	0	0	0	0	0	0	1	1	1	1	1	0	0	0	0	0	0	0
Green (63)	0	0	0	0	0	0	1	1	1	1	1	1	0	0	0	0	0	0	
Blue	Blue (00)	0	0	0	0	0	0	0	0	0	0	0	0	0	0	0	0	0	0
	Blue (01)	0	0	0	0	0	0	0	0	0	0	0	0	0	0	0	0	0	1
	Blue (02)	0	0	0	0	0	0	0	0	0	0	0	0	0	0	0	0	1	0
	Darker																		
	↓	↓	↓	↓	↓	↓	↓	↓	↓	↓	↓	↓	↓	↓	↓	↓	↓	↓	↓
	Brighter																		
	Blue (61)	0	0	0	0	0	0	0	0	0	0	0	0	1	1	1	1	0	1
	Blue (62)	0	0	0	0	0	0	0	0	0	0	0	0	1	1	1	1	1	0
Blue (63)	0	0	0	0	0	0	0	0	0	0	0	0	1	1	1	1	1	1	

7-4) Pixel Arrangement

The LCD module pixel arrangement is the stripe.

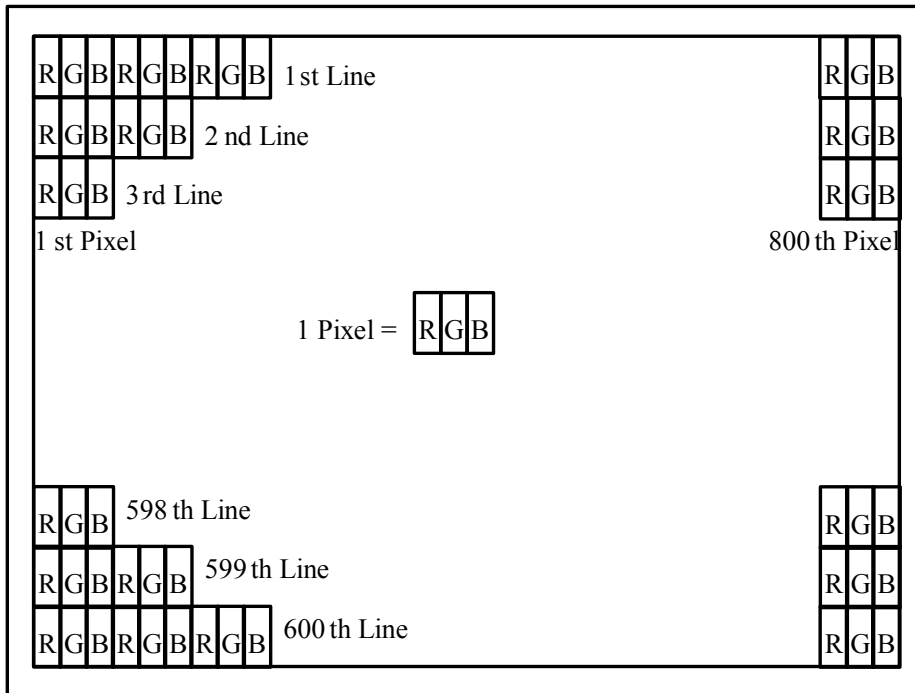

8. Power On Sequence

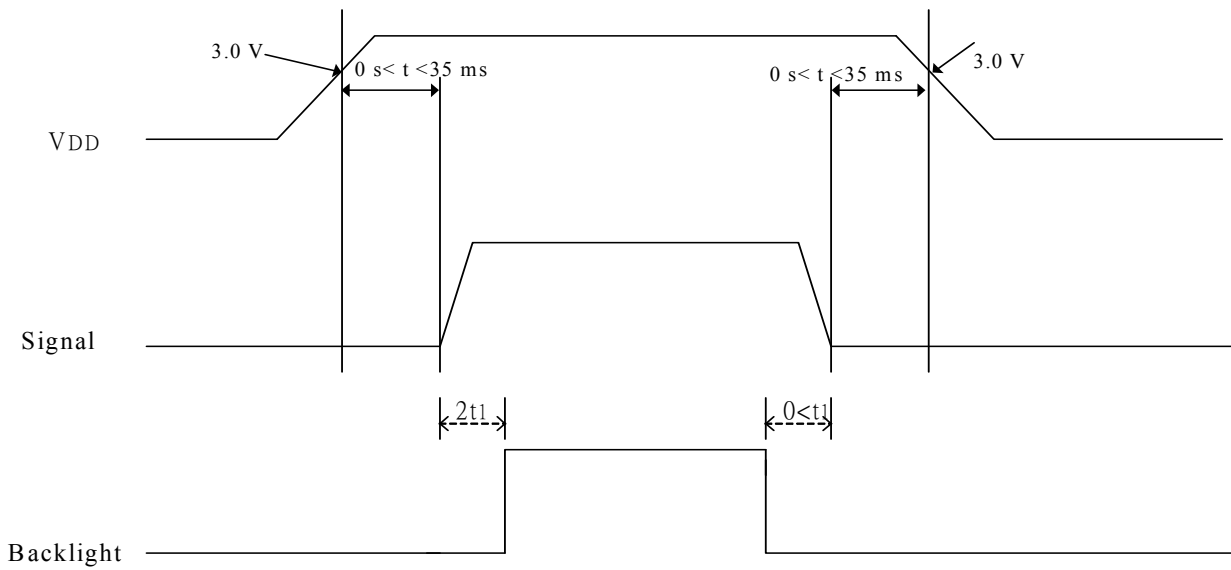

1. The supply voltage for input signals should be same as V_{DD} .
2. When the power is off , please keep whole signals (Hsync,Vsync,DENB,CLK, Data) low level or high impedance.

9. Optical Characteristics

9-1) Specification:

Ta = +25°C

Parameter	Symbol	Condition	MIN.	TYP.	MAX.	Unit	Remarks
Viewing Angle	Horizontal	θ	55	60	-	deg	
	Vertical	θ (to 12 o'clock)	35	40	-	deg	Note 9-1
		θ (to 6 o'clock)	50	55	-	deg	
Contrast Ratio	CR	Optimum direction	200	400	-	-	Note 9-2
Response time	Rise	Tr	-	15	50	ms	Note 9-4
	Fall	Tf	-	25	50	ms	
Luminance	L	$\theta = 0^\circ / \varphi = 0^\circ$	180	230	-	cd/m ²	I _{FL} =5mA, Note 9-3
			210	260	-		I _{FL} =7mA, Note 9-3
Luminance Uniformity	U		55	80	-	%	Note 9-5
White Chromaticity	x		0.29	0.32	0.35	-	
	y		0.32	0.35	0.38	-	
Lamp Life Time			20000	-	-	hr	I _{FL} =5mA
			14000	-	-	hr	I _{FL} =7mA
Cross Talk Ratio	CTK		-	-	3.5	%	Note 9-6

All the optical measurement shall be executed 30 minutes after backlight being turn-on. The optical characteristics shall be measured in dark room (ambient illumination on panel surface less than 1 Lux). The measuring configuration shows as following figure.

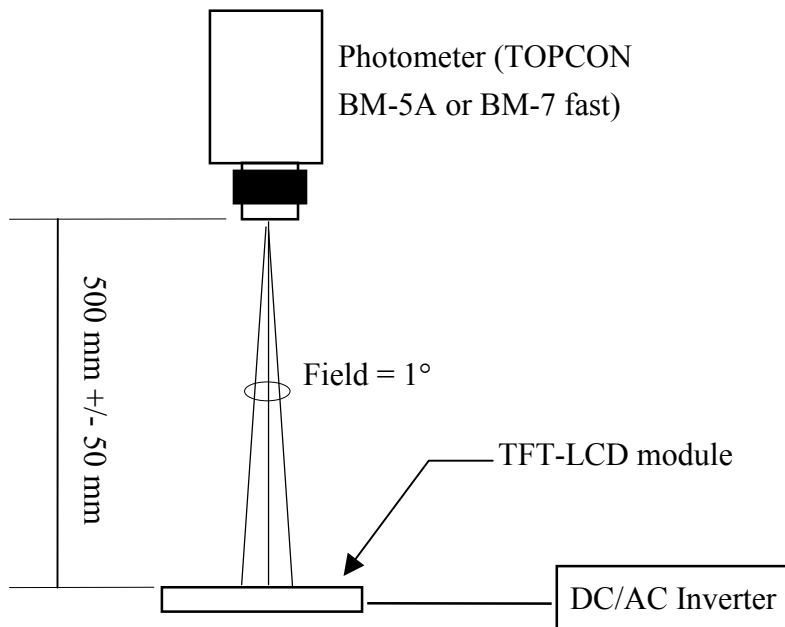

Optical characteristics measuring configuration

Note 9-1` : The definitions of viewing angles are as follows.

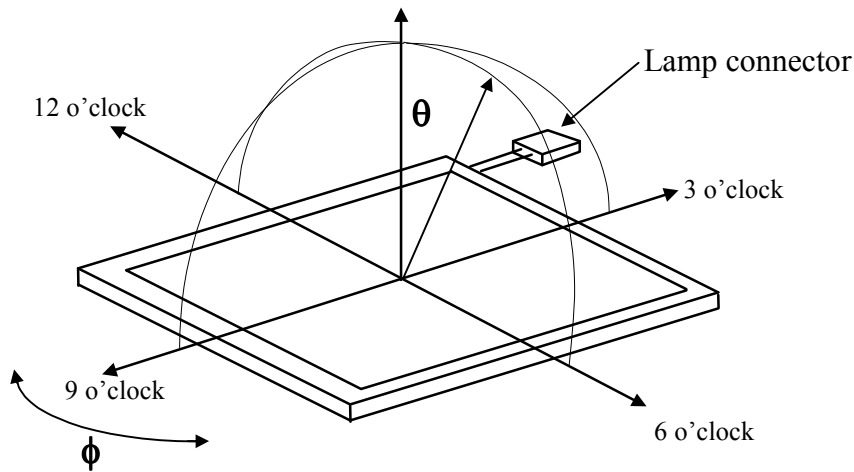

Note 9-2 : The definition of contrast ratio $CR = \frac{\text{Luminance at gray level 63}}{\text{Luminance at gray level 0}}$

Note 9-3 : The typical luminance value is measured at lamp current 5.0&7.0 mA. The max luminance value is measured at lamp current 7.0 mA.

Note 9-4: Definition of Response Time T_r and T_f :

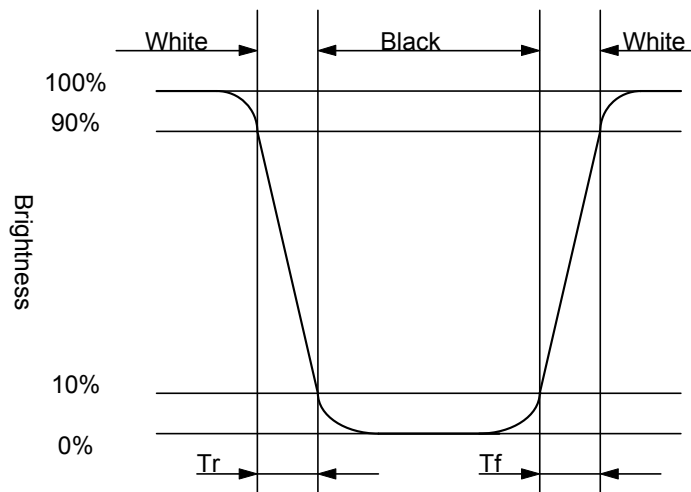

Note 9-5: The uniformity of LCD is defined as

$$U = \frac{\text{The Minimum Brightness of the 9 testing Points}}{\text{The Maximum Brightness of the 9 testing Points}}$$

Luminance meter : BM-5A or BM-7 fast(TOPCON)

Measurement distance : 500 mm +/- 50 mm

Ambient illumination : < 1 Lux

Measuring direction : Perpendicular to the surface of module

The test pattern is white (Gray Level 63).

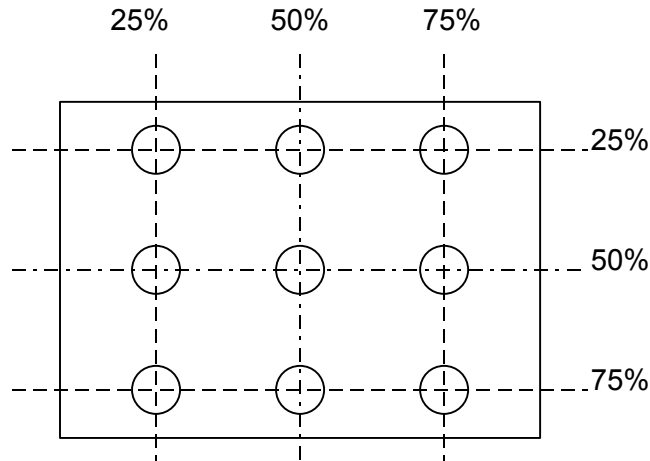

Note 9-6: Cross Talk (CTK) = $\frac{|YA-YB|}{YA} \times 100\%$

YA: Brightness of Pattern A

YB: Brightness of Pattern B

Luminance meter : BM 5A (TOPCON)

Measurement distance : 500 mm +/- 50 mm

Ambient illumination : < 1 Lux

Measuring direction : Perpendicular to the surface of module

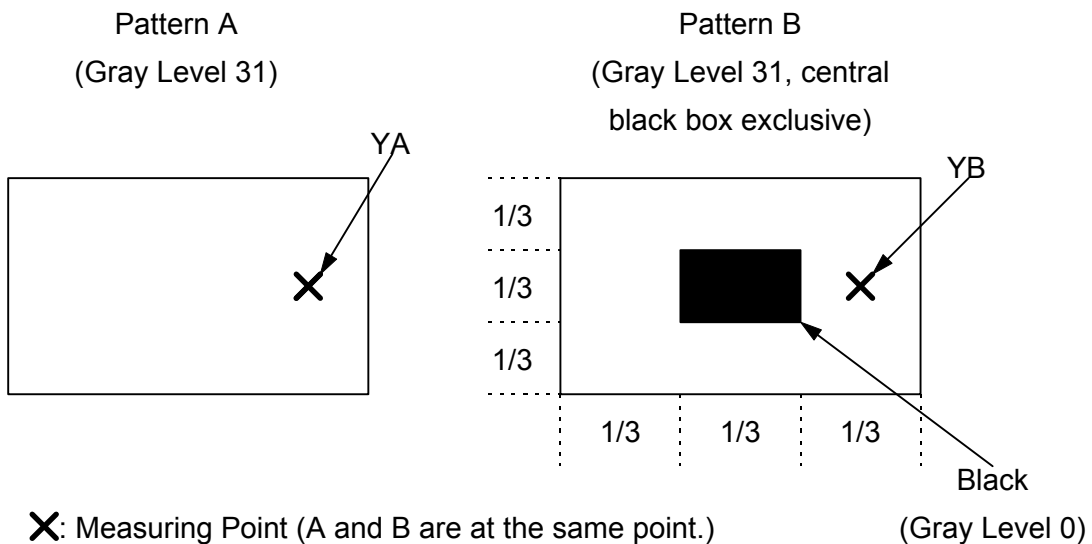

10. Handling Cautions

10-1) Mounting of module

- a) Please power off the module when you connect the input/output connector.
- b) Please connect the ground pattern of the inverter circuit surely. If the connection is not perfect, some following problems may happen possibly.
 1. The noise from the backlight unit will increase.
 2. The output from inverter circuit will be unstable.
 3. In some cases a part of module will heat.
- c) Polarizer which is made of soft material and susceptible to flaw must be handled carefully.
- d) Protective film (Laminator) is applied on surface to protect it against scratches and dirt. It is recommended to peel off the laminator before use and taking care of static electricity.

10-2) Precautions in mounting

- a) When metal part of the TFT-LCD module (shielding lid and rear case) is soiled, wipe it with soft dry cloth.
- b) Wipe off water drops or finger grease immediately. Long contact with water may cause discoloration or spots.
- c) TFT-LCD module uses glass which breaks or cracks easily if dropped or bumped on hard surface. Please handle with care.
- d) Since CMOS LSI is used in the module. So take care of static electricity and earth yourself when handling.

10-3) Adjusting module

- a) Adjusting volumes on the rear face of the module have been set optimally before shipment.
- b) Therefore, do not change any adjusted values. If adjusted values are changed, the specifications described may not be satisfied.

10-4) Others

- a) Do not expose the module to direct sunlight or intensive ultraviolet rays for many hours.
- b) Store the module at a room temperature place.
- c) The voltage of beginning electric discharge may over the normal voltage because of leakage current from approach conductor by to draw lump read lead line around.
- d) If LCD panel breaks, it is possibly that the liquid crystal escapes from the panel. Avoid putting it into eyes or mouth. When liquid crystal sticks on hands, clothes or feet. Wash it out immediately with soap.
- e) Observe all other precautionary requirements in handling general electronic components.
- f) Please adjust the voltage of common electrode as material of attachment by 1 module.

11. Reliability Test

No	Test Item	Test Condition	Remark
1	High Temperature Storage Test	Ta = +70°C, 240 hrs	
2	Low Temperature Storage Test	Ta = -30°C, 240 hrs	
3	High Temperature Operation Test	Ta = +70°C, 240 hrs	
4	Low Temperature Operation Test	Ta = -20°C, 240 hrs	
5	High Temperature & High Humidity Operation Test	Ta = +60°C, 90%RH, 240 hrs (No Condensation)	
6	Thermal Cycling Test (non-operating)	-20°C ←→ +70°C, 100 Cycles 1Hr 1Hr	
7	Vibration Test (non-operating)	Frequency : 10 ~ 57 Hz, Amplitude : 0.15 mm, 58~500Hz, 1G Sweep time: 11 min Test Period: 3 hrs (1 hr for each direction of X, Y, Z)	
8	Shock Test (non-operating)	80G, 6ms, X, Y, Z 1 times for each direction	
9	Electron Static Discharge	C=150pF, R=330Ω Contact=±8KV Air=±15KV 10 times/terminal	

Ta: ambient temperature

[Criteria]

In the standard conditions, there is not display function NG issue occurred. (including : line defect ,no image). All the cosmetic specification is judged before the reliability stress.

12. Block Diagram

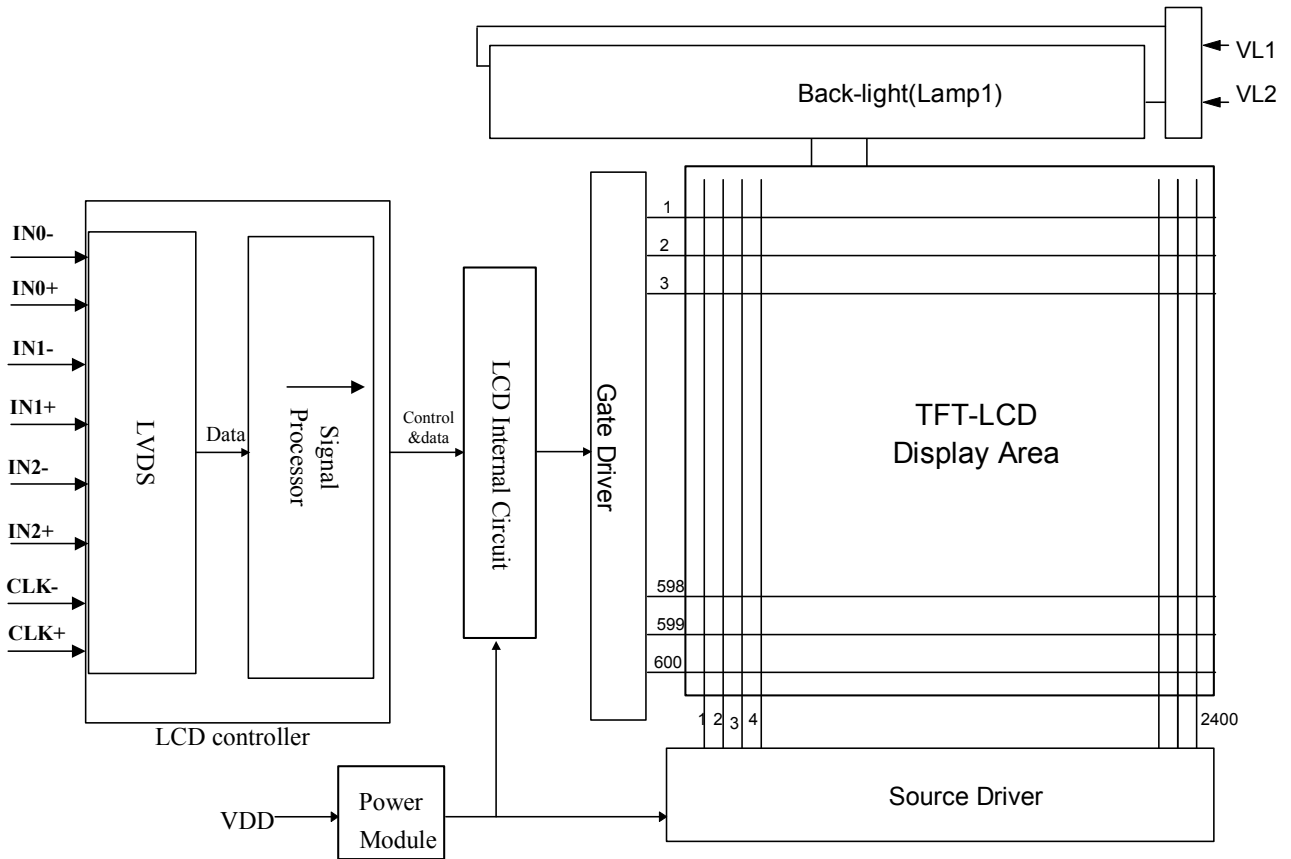

13. Packing

ZONE	REV.	DOCUMENT NO.	DESCRIPTION	DATE	REV.BY																									
<p>NOTE:</p> <p>1.Q'TY: 10 pcs module/carton. 2.Dimension: 530*295*230mm 3.Weight: 5.4 Kg</p>																														
<table border="1" style="width:100%; border-collapse: collapse;"> <thead> <tr> <th>ITEM</th> <th>PART NO.</th> <th>DESCRIPTION</th> <th>QTY</th> <th>REMARK</th> </tr> </thead> <tbody> <tr> <td>4</td> <td>50-0100111</td> <td>CARTON</td> <td>1</td> <td></td> </tr> <tr> <td>3</td> <td>50-0500291</td> <td>防静电气泡袋 Pink</td> <td>10</td> <td>防静电</td> </tr> <tr> <td>2</td> <td>PD104SLA</td> <td>10.4"COG module</td> <td>10</td> <td></td> </tr> <tr> <td>1</td> <td>50-0301281</td> <td>瓦楞隔板缓冲材(10u)</td> <td>1</td> <td>上盖+底座</td> </tr> </tbody> </table>						ITEM	PART NO.	DESCRIPTION	QTY	REMARK	4	50-0100111	CARTON	1		3	50-0500291	防静电气泡袋 Pink	10	防静电	2	PD104SLA	10.4"COG module	10		1	50-0301281	瓦楞隔板缓冲材(10u)	1	上盖+底座
ITEM	PART NO.	DESCRIPTION	QTY	REMARK																										
4	50-0100111	CARTON	1																											
3	50-0500291	防静电气泡袋 Pink	10	防静电																										
2	PD104SLA	10.4"COG module	10																											
1	50-0301281	瓦楞隔板缓冲材(10u)	1	上盖+底座																										
MTL.SPEC.		UNSPECIFIED TOL'S		REMARK																										
		ANGLE																												
		ROUGHNESS																												
APPROVE	Frank	'07.01.05	SCALE	UNIT	SHEET																									
CHECK	Frank	'07.01.05			1 of 1																									
DRAWN	Joseph	'07.01.05	MTL.NO.		DWG FILE:																									
					REV. 02																									
					A4 SIZE																									

元太科技工業股份有限公司
Prime View International Co., Ltd.

DWG.TITLE
PD104SLA MODULE PACKING