

TECHNICAL SPECIFICATION
MODEL NO : PD104SLE

The content of this information is subject to be changed without notice.
Please contact PVI or its agent for further information.

Customer's Confirmation

Customer _____

Date _____

By _____

PVI's Confirmation

Dep	FAE	Panel Design	Electronic Design	Mechanical Design	Product Verification	Prepared by
SIGN						

TECHNICAL SPECIFICATION**CONTENTS**

<i>NO.</i>	<i>ITEM</i>	<i>PAGE</i>
-	Cover	1
-	Contents	2
1	Application	3
2	Features	3
3	Mechanical Specifications	3
4	Mechanical Drawing of TFT-LCD module	4
5	Input Terminals	5
6	Absolute Maximum Ratings	7
7	Electrical Characteristics	7
8	Power On Sequence	15
9	Optical Characteristics	16
10	Handling Cautions	19
11	Reliability Test	20
12	Block Diagram	21
13	Packing	22
-	Revision History	-

1.Application

This data sheet applies to a color TFT LCD module, PD104SLE.

PD104SLE module applies to notebook PC, sub-note-book PC and other OA product, which require high quality flat panel display. **This module is not designed for aerospace, avionics, medical, F/A, transportation, car or any other products, which require extreme level of reliability.**

Prime View assume no responsibility for any damage resulting from the use of the device which dose not comply with the instructions and the precautions in these specification sheet.

2. Features

- . Amorphous silicon TFT LCD panel with LED back-light unit
- . Pixel in stripe configuration
- . Slim and compact, designed for O/A application
- . Display Colors : 262,144 colors
- . Optimum Viewing Direction : 6 o'clock
- . 3.3V LVDS interface standard: THC63LVDF64A as receiver
- . +3.3V DC supply voltage for TFT LCD panel driving

3.Mechanical Specifications

Parameter	Specifications	Unit
Screen Size	26.4(diagonal)	cm
	10.4 (diagonal)	inch
Display Format	800×(R, G, B)×600	dot
Display Colors	262,144	
Active Area	211.2(H)×158.4 (V)	mm
Pixel Pitch	0.264 (H)×0.264 (V)	mm
Pixel Configuration	Stripe	
Outline Dimension	238.6 (w)×171.0(H)×6.0(typ.) (D)	mm
Weight	TBD	g
LED Back-light	36-LED	
Surface treatment	Anti-glare	
Display mode	Normally white	

4. Mechanical Drawing of TFT-LCD Module

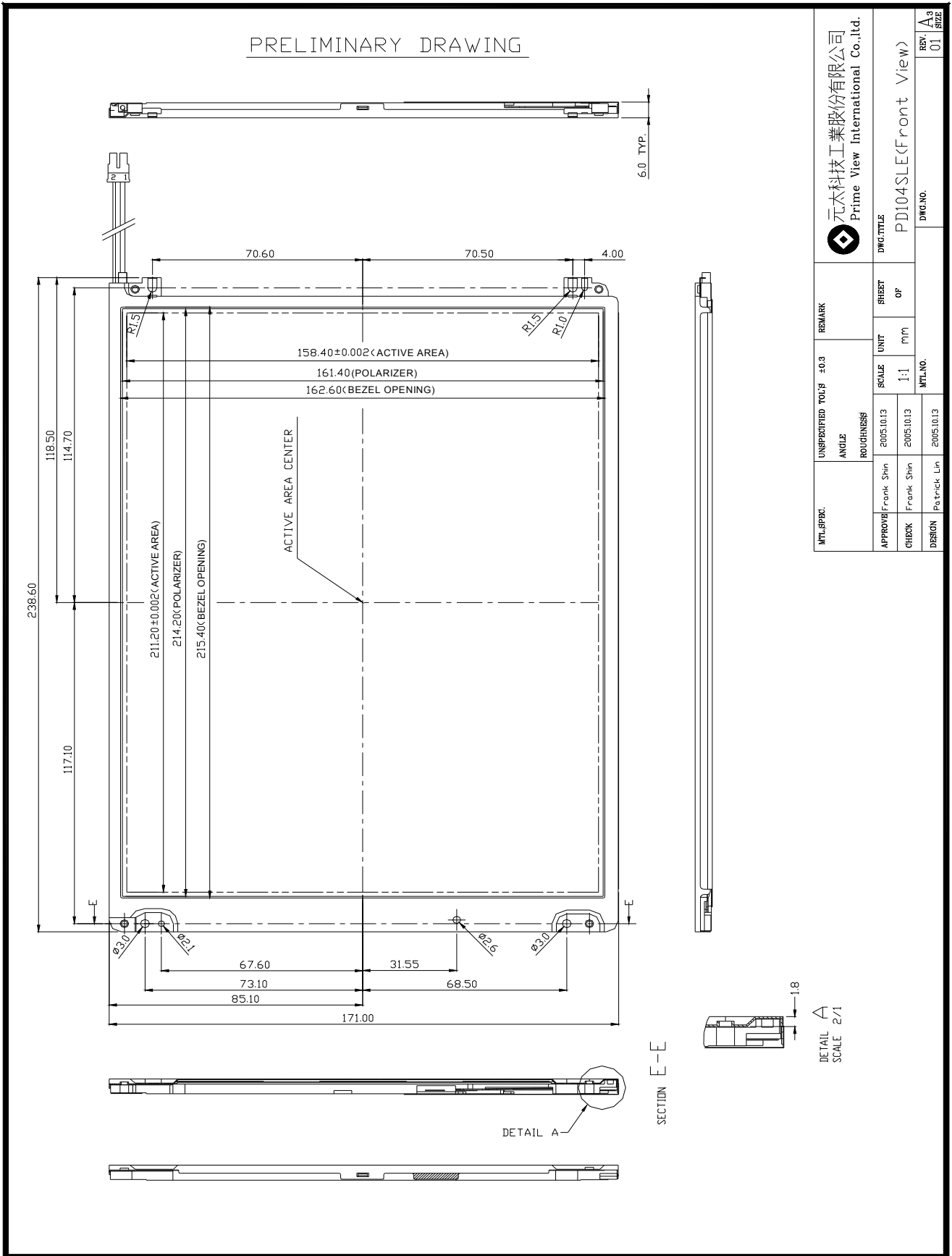

 元太科技工業股份有限公司 Prime View International Co., Ltd.		DWG. TITLE PD104SLE(Front View)		REV. A 01
MTL. SPEC.	UNPROOFED TOL. ± 0.3	REMARK	SHEET OF	DWG. NO.
APPROV. Frank Shin	ANGLE	SCALE 1:1	UNIT mm	MTL. NO.
CHECK Frank Shin	ROUGHNESS	2005.10.13	2005.10.13	2005.10.13
DESIGN Patrick Lin	2005.10.13	2005.10.13	2005.10.13	2005.10.13

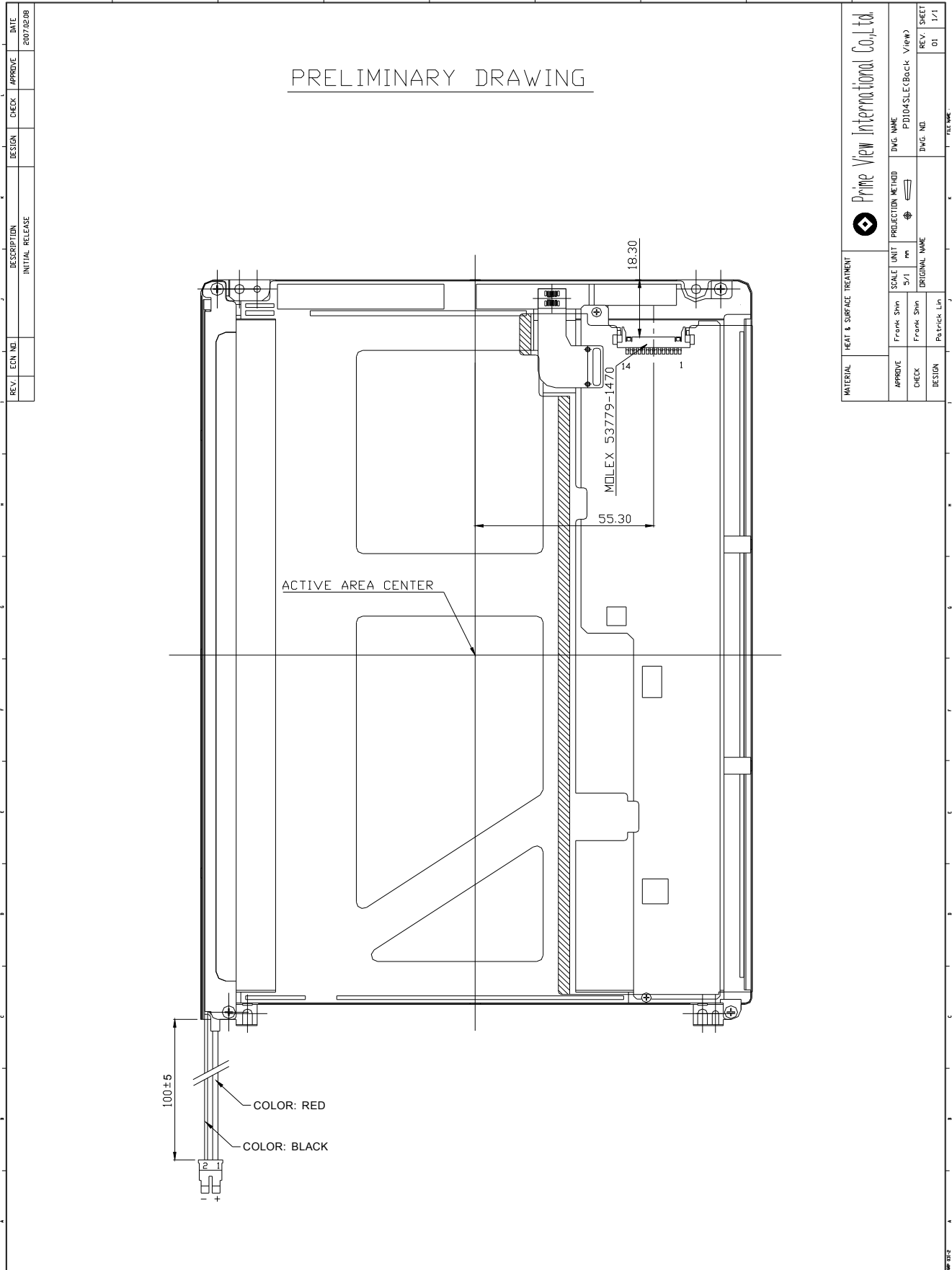

5. Input Terminals

5-1) TFT-LCD Panel Driving

Connector type: Molex 53779-1470

Pin No.	Symbol	Function	Remark
1	VDD	Power supply : +3.3V	
2	VDD	Power supply : +3.3V	
3	GND	Ground	
4	GND	Ground	
5	IN0-	Pixel data Transmission pair 0 (negative -)	
6	IN0+	Pixel data Transmission pair 0 (positive +)	
7	IN1-	Pixel data Transmission pair 1 (negative -)	
8	IN1+	Pixel data Transmission pair 1 (positive +)	
9	IN2-	Pixel data Transmission pair 2 (negative -)	
10	IN2+	Pixel data Transmission pair 2 (positive +)	
11	CLK-	Sampling Clock (negative -)	
12	CLK+	Sampling Clock (positive +)	
13	GND	Ground	
14	GND	Ground	

Recommended Transmitter (THC63LVDM63A Thine) to PD104SLE interface Assignment:

Input terminal of THC63LVDM63A		Graphic controller output signal		Output signal symbol	To PD104SLE interface terminal(Symbol)
Symbol	No.	Symbol	Function		
TIN0	44	R0	Red pixel data (LSB)	Tout0- Tout0+	No.5 : IN0-
TIN1	45	R1	Red pixel data		
TIN2	47	R2	Red pixel data		
TIN3	48	R3	Red pixel data		
TIN4	1	R4	Red pixel data		
TIN5	3	R5	Red pixel data(MSB)		No.6 : IN0+
TIN6	4	G0	Green pixel data (LSB)	Tout1- Tout1+	No.7 : IN1-
TIN7	6	G1	Green pixel data		
TIN8	7	G2	Green pixel data		
TIN9	9	G3	Green pixel data		
TIN10	10	G4	Green pixel data		
TIN11	12	G5	Green pixel data(MSB)		No.8 : IN1+
TIN12	13	B0	Blue pixel data(LSB)	Tout2- Tout2+	No.9 : IN2-
TIN13	15	B1	Blue pixel data		
TIN14	16	B2	Blue pixel data		
TIN15	18	B3	Blue pixel data		
TIN16	19	B4	Blue pixel data		
TIN17	20	B5	Blue pixel data(MSB)		No.10 : IN2+
TIN18	22	HSYNC	Horizontal sync signal	TCLK out- TCLK out+	No.11 : CLK - No.12 : CLK +
TIN19	23	VSYNC	Vertical sync signal		
TIN20	25	DENB	Compound Synchronization signal		
TCLK in	26	CLK	Data sampling clock		

LVDS Interface Block Diagram

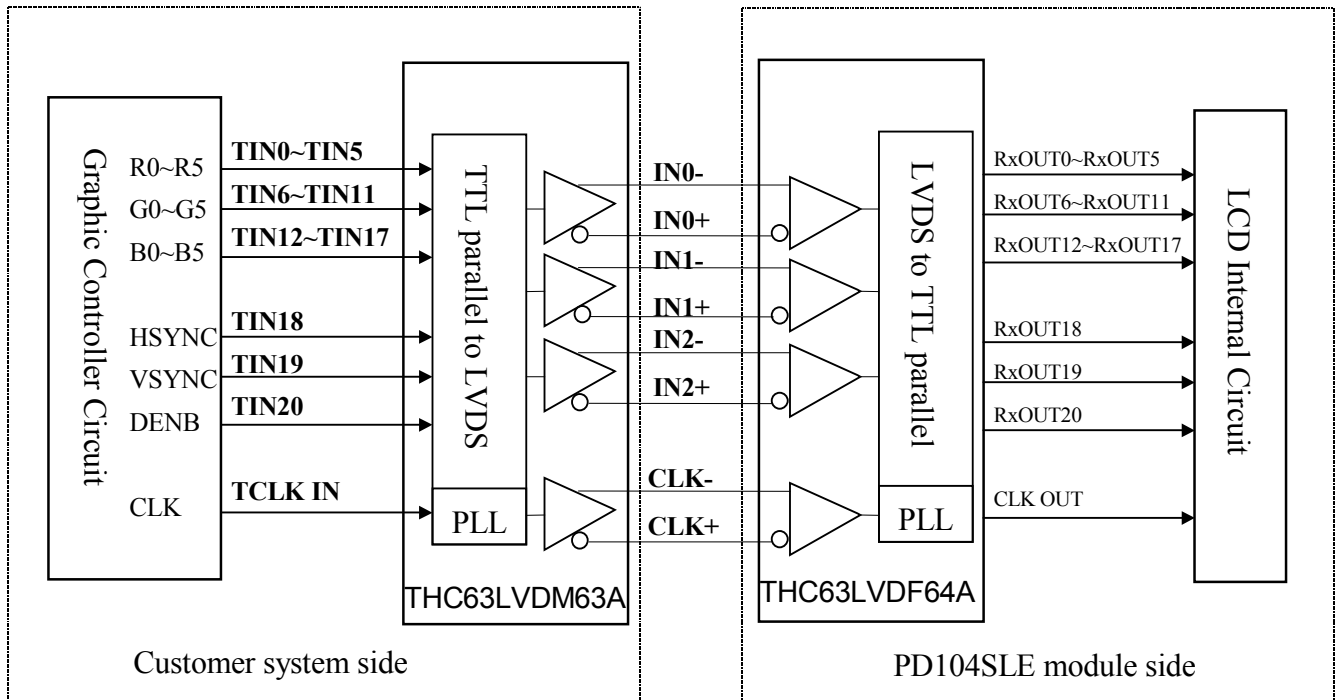

5-2) Backlight driving

Connector type : “B8R- 02VS-1” of Japan Solderless Terminal MFG Co. LTD

Pin No	Symbol	Description	Remark
1	+	Input terminal (Positive electrode side)	Wire color : Red
2	-	Input terminal (Ground side)	Wire color : Black

6. Absolute Maximum Ratings:

GND=0V, Ta=25°C

Parameters	Symbol	MIN.	MAX.	Unit	Remark
Supply Voltage	V _{DD}	-0.3	+4.0	V	
Input Signals Voltage	V _{IN}	-0.3	VDD+0.3	V	Note 61

Note 6-1: LVDS signal.

7. Electrical Characteristics

7-1) Recommended Operating Conditions:

GND = 0V , Ta = 25°C

Item	Symbol	Min.	Typ.	Max.	Unit	Remark
Supply Voltage	VDD	3.0	3.3	3.6	V	
Current Dissipation	I _{DD}	-	350	450	mA	Note 71
LVDS Differential input high threshold	V _{TH}	-	-	100	mV	Note 72
LVDS Differential input low threshold	V _{TL}	-100	-	-	-	

Note 7-1 : To test the current dissipation of VDD, using the “color bars” testing pattern shown as below.

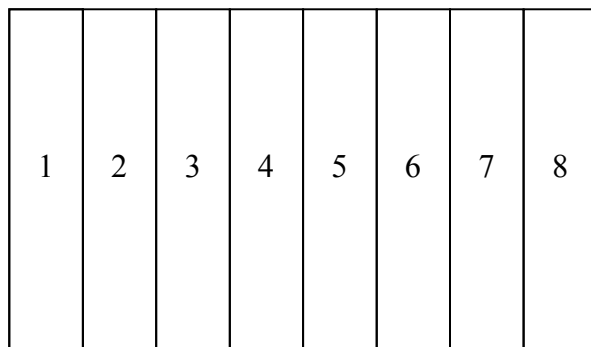

1. White
2. Yellow
3. Cyan
4. Green
5. Magenta
6. Red
7. Blue
8. Black

Idd current dissipation testing pattern

Note 7-2 :Please refers to THC63LVDF63A specification by THINE Corporation. This LCD module conforms to LVDS standard.

7-2) Recommended driving condition for LED back light

GND = 0 V , Ta = 25°C

Parameter	Symbol	Min	TYP	MAX	Unit	Remark
Supply voltage of LED backlight	V _{LED}	-	TBD	TBD	V	I _{LED} = 20 mA
Supply current of LED backlight	I _{LED}	-	20	-	mA	Note 7-3
Backlight Power Consumption	P _{LED}	-	TBD	TBD	W	Note 7-4

Note 7-3 : The LED driving condition is defined for each LED module. (3 LED Serial)

Note 7-4 : $P_{LED} = V_{LED-1} * I_{LED-1} + V_{LED-2} * I_{LED-2} \dots + V_{LED-11} * I_{LED-11} + V_{LED-12} * I_{LED-12}$

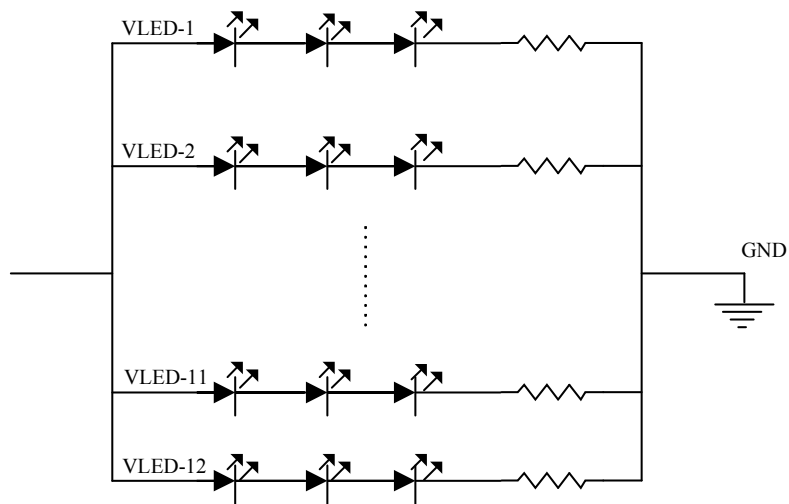

7-3) Input signal timing :

(A) Timing Specifications (DENB Mode):

Item	Symbol	Min.	Typ.	Max.	Unit	Remark
Frame Cycling Period	t1	604 X t3	628X t3	800 X t3	-	
		14	16.58	20	ms	
Vertical Display Period	t2	600 X t3	600 X t3	600 X t3	-	
Horizontal Scanning Time	t3	920 X t5	1056 X t5	1064 X t5	-	
		24	26.4	33	μ s	
Horizontal Display Period	t4	800 X t5	800 X t5	800 X t5	-	
Clock Cycle	t5	20	25.0	31.25	ns	
Clock High Level Time	t6	9.0	-	-	ns	
Clock Low Level Time	t7	9.0	-	-	ns	
Hold time	t8	4.0	-	-	ns	
Set-up time	t9	5.0	-	-	ns	

(B). Timing Specifications (SYNC Mode)

	Item	Symbol	Min.	Typ.	Max.	Unit	Remark	
HSYNC	Period	Hp	24	26.4	33	us		
			920	1056	1064	tc		
	Display period	Hdp	800	800	800	tc		
	Pulse width	Hpw	12	128	202	tc		
	Back-porch	Hbp	12	86	202	tc		
	Front-porch	Hfp	42	42	42	tc		
	Hpw+Hbp			214	214	214	tc	
	Hsync-CLK	Hhc	10	-	Tc-10	ns		
Vsync-Hsync	Hvh	0	0	200	tc			
VSYNC	Period (Frame cycling period)	Vp	14	16.58	20	ms	Note 7-5	
			604	628	800	Hp		
	Display period	Vdp	600	600	600	Hp		
	Pulse width	Vpw	2	4	27	Hp		
	Back-porch	Vbp	0	23	25	Hp		
	Front-porch	Vfp	1	1	1	Hp		
	Vpw+Vbp			27	27	27	Hp	

Note 7-5 : Frame cycling period is optimum in 16.58ms.(60Hz)

Note 7-6: DENB pin have high priority than SYNC mode(HSVC+VSYNC). When IC only use SYNC pin, DENB pin have to connect to ground.

(C)Timing Chart:

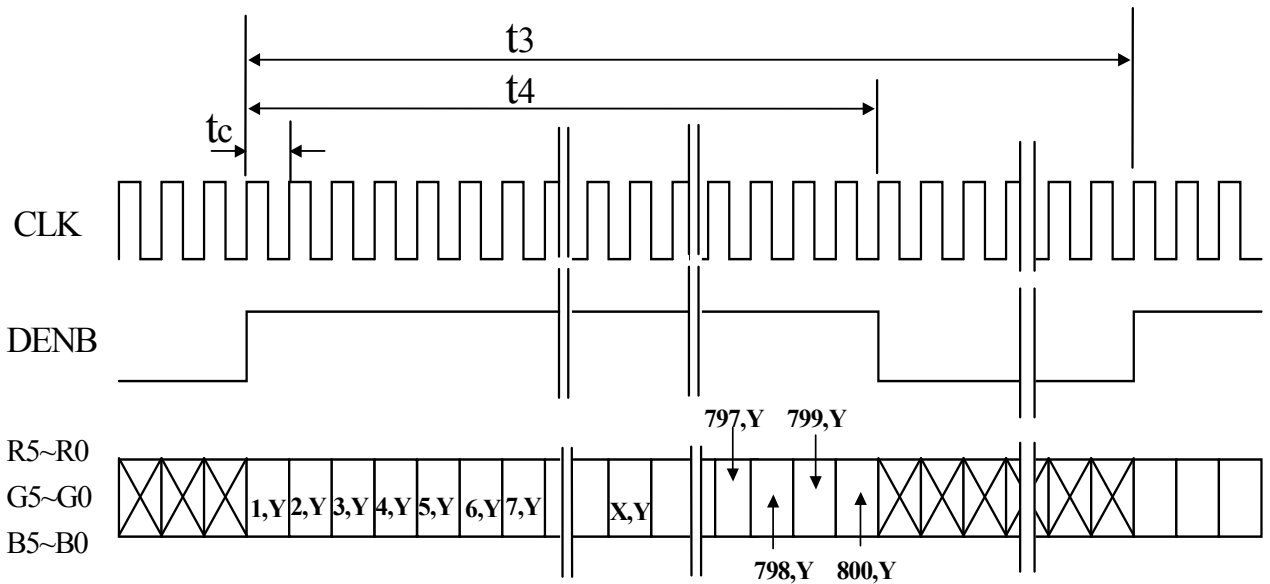
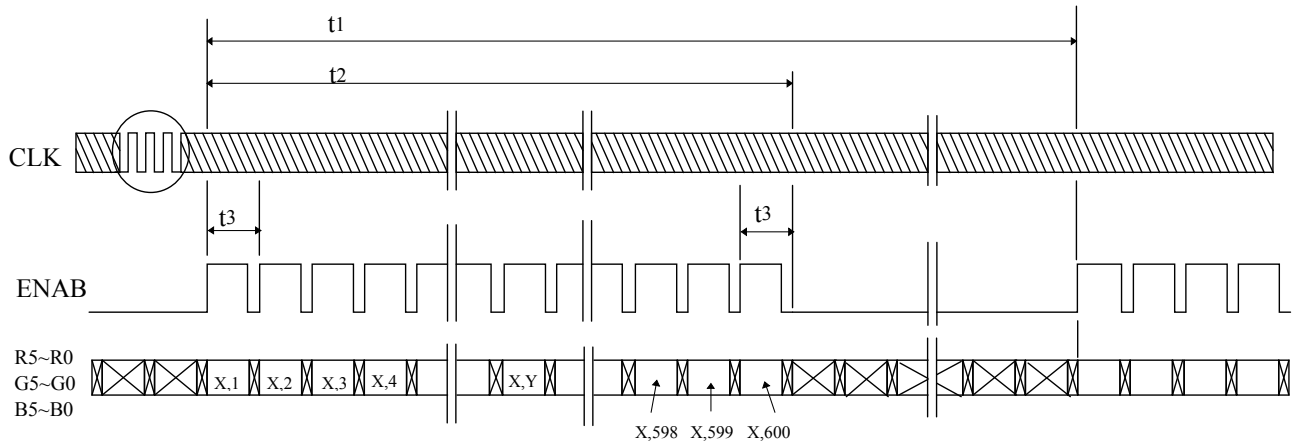

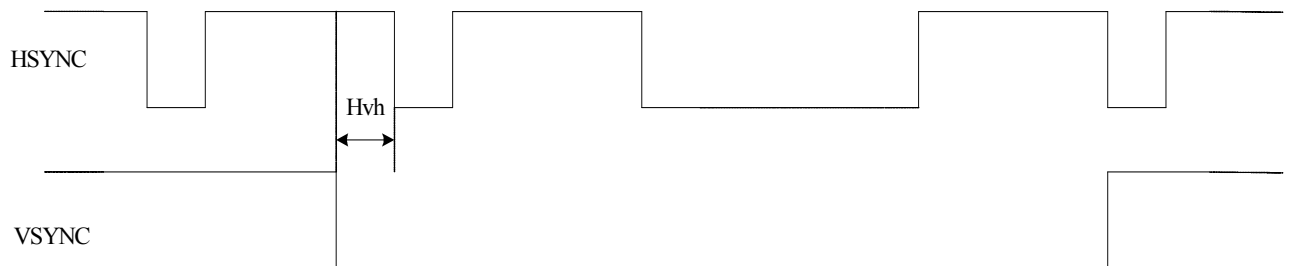
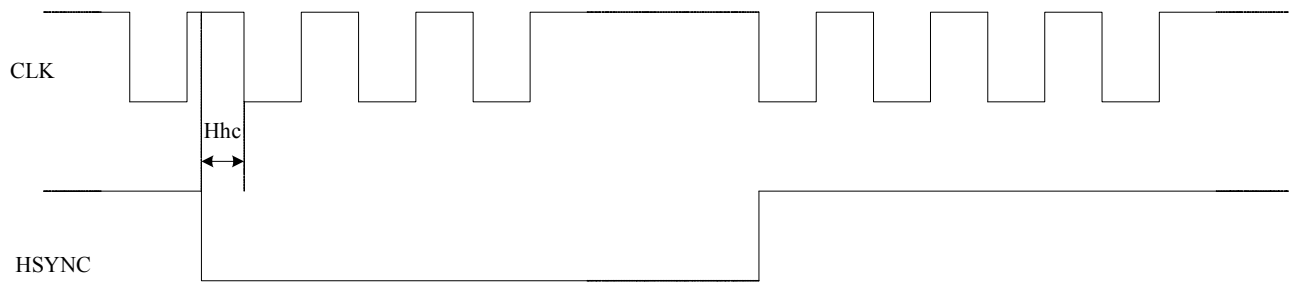
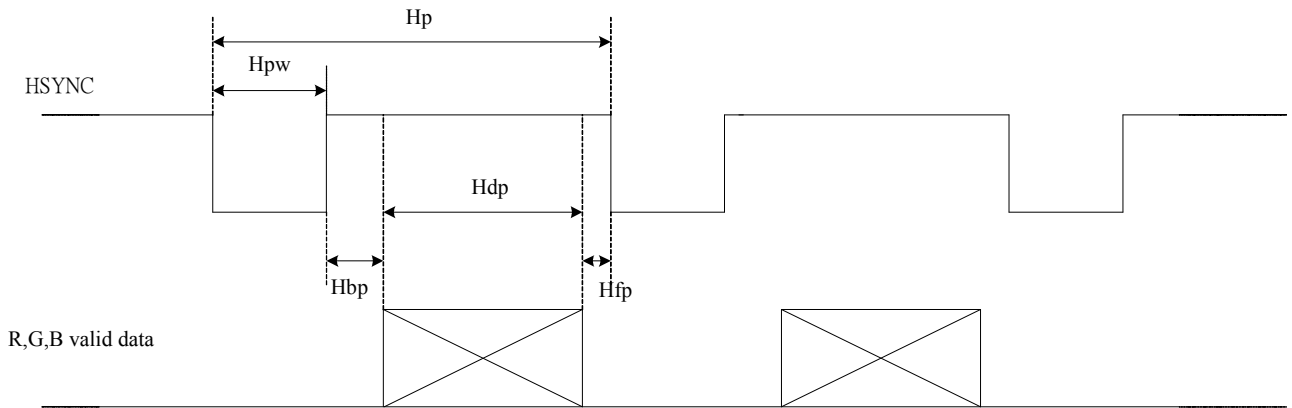

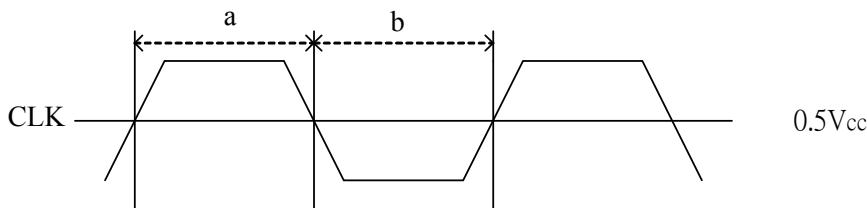
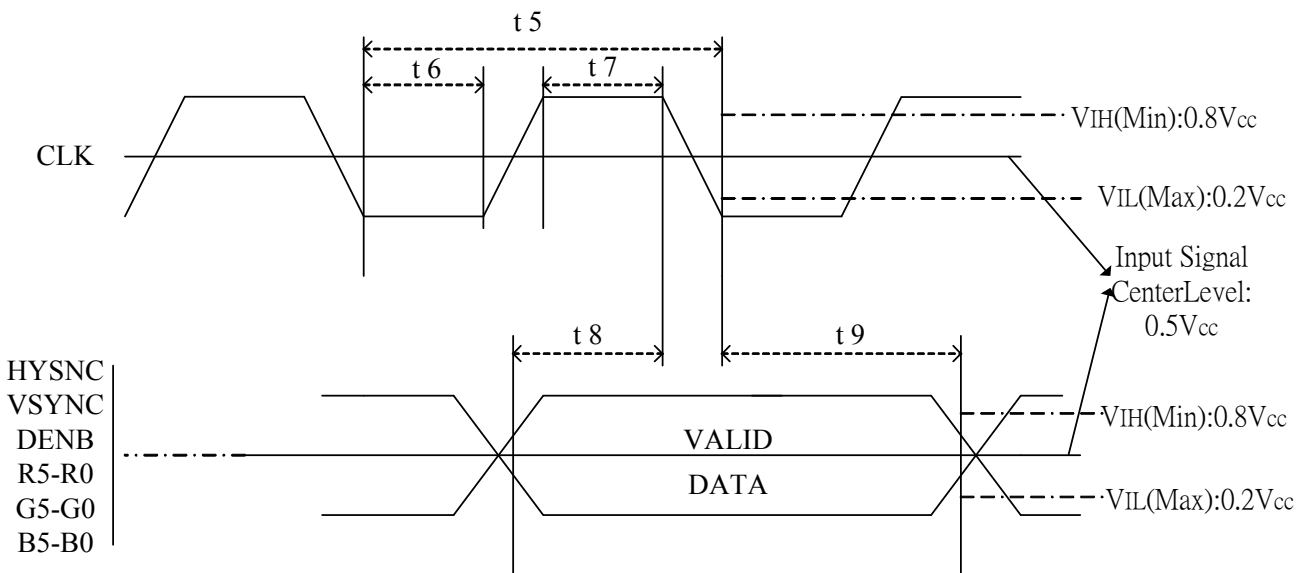
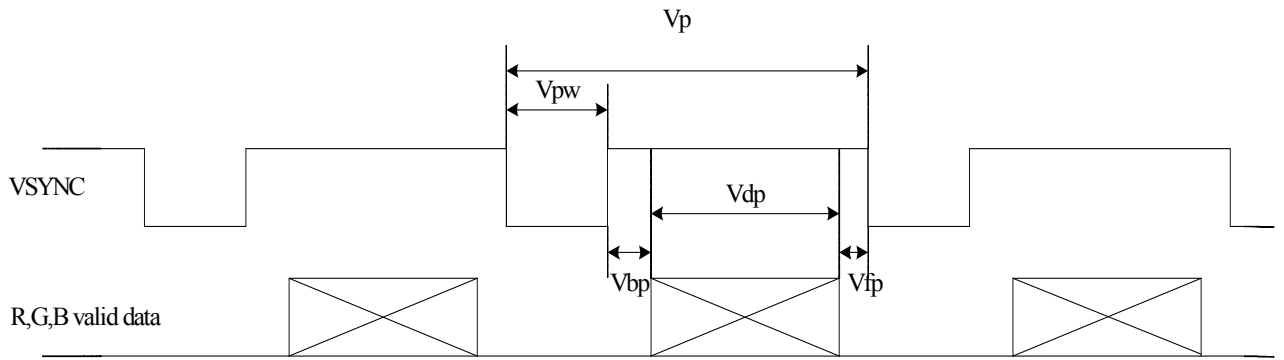

Duty (a ,b) : $50 \pm 10\%$

7-3) Display Color and Gray Scale Reference

Color		Input Color Data																	
		Red						Green						Blue					
		R5	R4	R3	R2	R1	R0	G5	G4	G3	G2	G1	G0	B5	B4	B3	B2	B1	B0
Basic Colors	Black	0	0	0	0	0	0	0	0	0	0	0	0	0	0	0	0	0	0
	Red (63)	1	1	1	1	1	1	0	0	0	0	0	0	0	0	0	0	0	0
	Green (63)	0	0	0	0	0	0	1	1	1	1	1	1	0	0	0	0	0	0
	Blue (63)	0	0	0	0	0	0	0	0	0	0	0	0	1	1	1	1	1	1
	Cyan	0	0	0	0	0	0	1	1	1	1	1	1	1	1	1	1	1	1
	Magenta	1	1	1	1	1	1	0	0	0	0	0	0	1	1	1	1	1	1
	Yellow	1	1	1	1	1	1	1	1	1	1	1	1	0	0	0	0	0	0
	White	1	1	1	1	1	1	1	1	1	1	1	1	1	1	1	1	1	1
Red	Red (00)	0	0	0	0	0	0	0	0	0	0	0	0	0	0	0	0	0	0
	Red (01)	0	0	0	0	0	1	0	0	0	0	0	0	0	0	0	0	0	0
	Red (02)	0	0	0	0	1	0	0	0	0	0	0	0	0	0	0	0	0	0
	Darker																		
	↓	↓	↓	↓	↓	↓	↓	↓	↓	↓	↓	↓	↓	↓	↓	↓	↓	↓	↓
	Brighter																		
	Red (61)	1	1	1	1	0	1	0	0	0	0	0	0	0	0	0	0	0	0
	Red (62)	1	1	1	1	1	0	0	0	0	0	0	0	0	0	0	0	0	0
	Red (63)	1	1	1	1	1	1	0	0	0	0	0	0	0	0	0	0	0	0
Green	Green (00)	0	0	0	0	0	0	0	0	0	0	0	0	0	0	0	0	0	0
	Green (01)	0	0	0	0	0	0	0	0	0	0	0	1	0	0	0	0	0	0
	Green (02)	0	0	0	0	0	0	0	0	0	0	1	0	0	0	0	0	0	0
	Darker																		
	↓	↓	↓	↓	↓	↓	↓	↓	↓	↓	↓	↓	↓	↓	↓	↓	↓	↓	↓
	Brighter																		
	Green (61)	0	0	0	0	0	0	1	1	1	1	0	1	0	0	0	0	0	0
	Green (62)	0	0	0	0	0	0	1	1	1	1	1	0	0	0	0	0	0	0
	Green (63)	0	0	0	0	0	0	1	1	1	1	1	1	0	0	0	0	0	0
Blue	Blue (00)	0	0	0	0	0	0	0	0	0	0	0	0	0	0	0	0	0	0
	Blue (01)	0	0	0	0	0	0	0	0	0	0	0	0	0	0	0	0	0	1
	Blue (02)	0	0	0	0	0	0	0	0	0	0	0	0	0	0	0	0	1	0
	Darker																		
	↓	↓	↓	↓	↓	↓	↓	↓	↓	↓	↓	↓	↓	↓	↓	↓	↓	↓	↓
	Brighter																		
	Blue (61)	0	0	0	0	0	0	0	0	0	0	0	0	1	1	1	1	0	1
	Blue (62)	0	0	0	0	0	0	0	0	0	0	0	0	1	1	1	1	1	0
	Blue (63)	0	0	0	0	0	0	0	0	0	0	0	0	1	1	1	1	1	1

7-4) Pixel Arrangement

The LCD module pixel arrangement is the stripe.

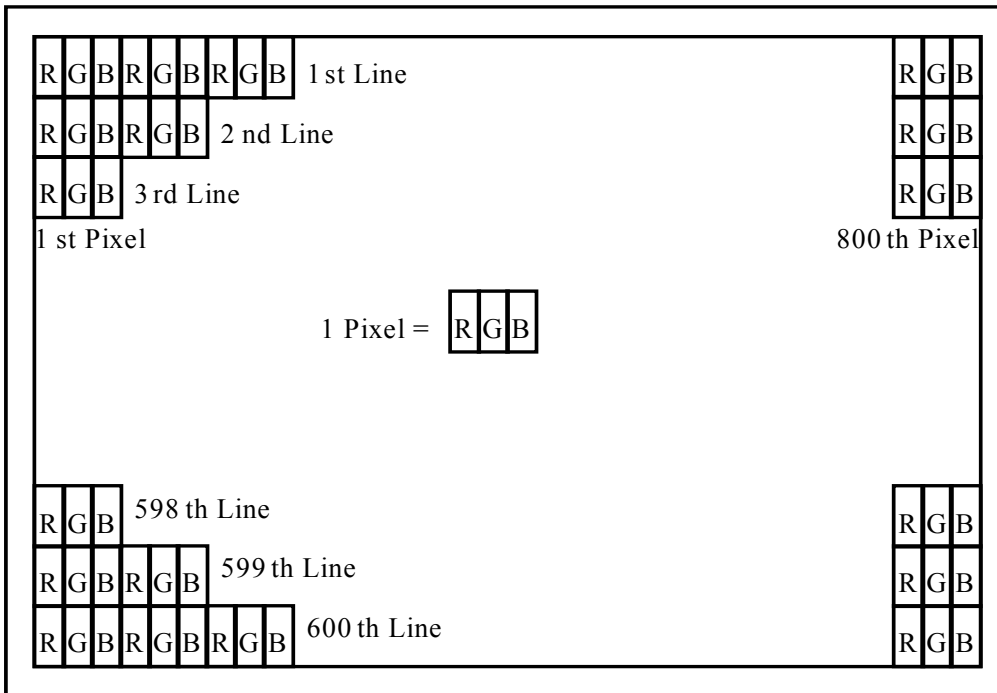

8 .Power On Sequence

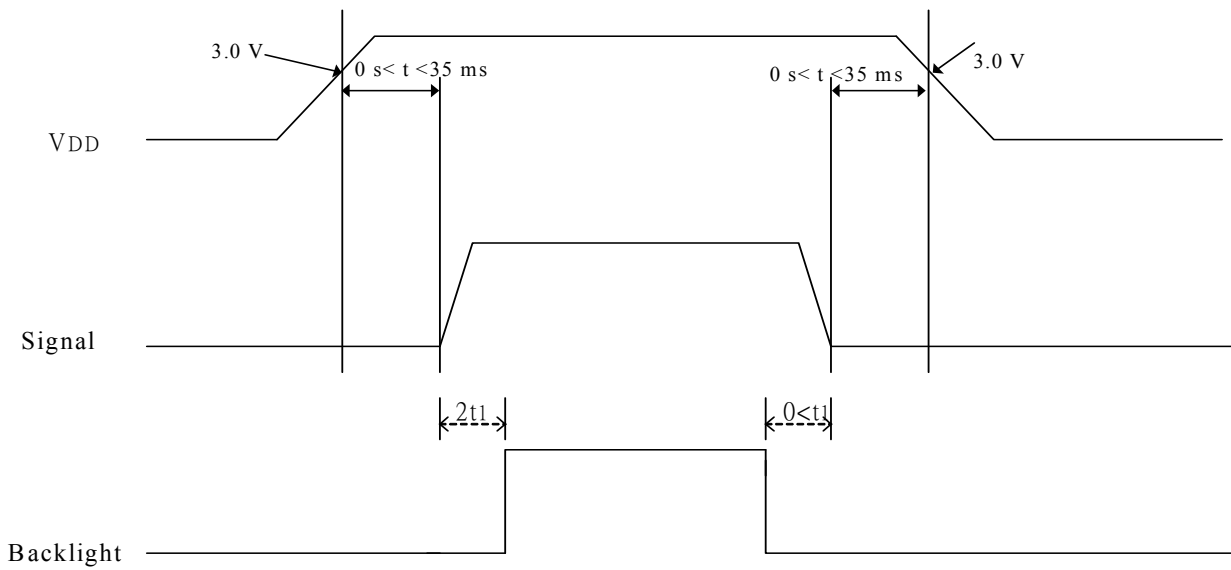

1. The supply voltage for input signals should be same as V_{DD} .
2. When the power is off , please keep whole signals (Hsync,Vsync,DENB,CLK, Data) low level or high impedance.

9. Optical Characteristics

9-1) Specification:

Ta = 25°C

Parameter	Symbol	Condition	MIN.	TYP.	MAX.	Unit	Remarks
Viewing Angle	Horizontal	θ	40	45	-	deg	
	Vertical	θ (to 12 o'clock)	10	15	-	deg	Note 91
		θ (to 6 o'clock)	35	40	-	deg	
Contrast Ratio	CR	Optimum direction	200	400	-	-	Note 92
Response time	Rise	Tr	-	15	50	ms	Note 94
	Fall	Tf	-	25	50	ms	
Luminance	L	$\theta = 0^\circ / \varphi = 0^\circ$	200	230	-	cd/m ²	Note 93
Luminance Uniformity	U	-	TBD	TBD	-	%	Note 95
White Chromaticity	x	$\theta = 0^\circ / \varphi = 0^\circ$	TBD	TBD	TBD	-	
	y	$\theta = 0^\circ / \varphi = 0^\circ$	TBD	TBD	TBD	-	
LED Life Time	-	25°C	20000	-	-	hr	Note 97
Cross Talk Ratio	CTK	-	-	-	3.5	%	Note 96
NTSC%	-	-	-	TBD	-	-	

All the optical measurement shall be executed 30 minutes after backlight being turn-on. The optical characteristics shall be measured in dark room (ambient illumination on panel surface less than 1 Lux). The measuring configuration shows as following figure.

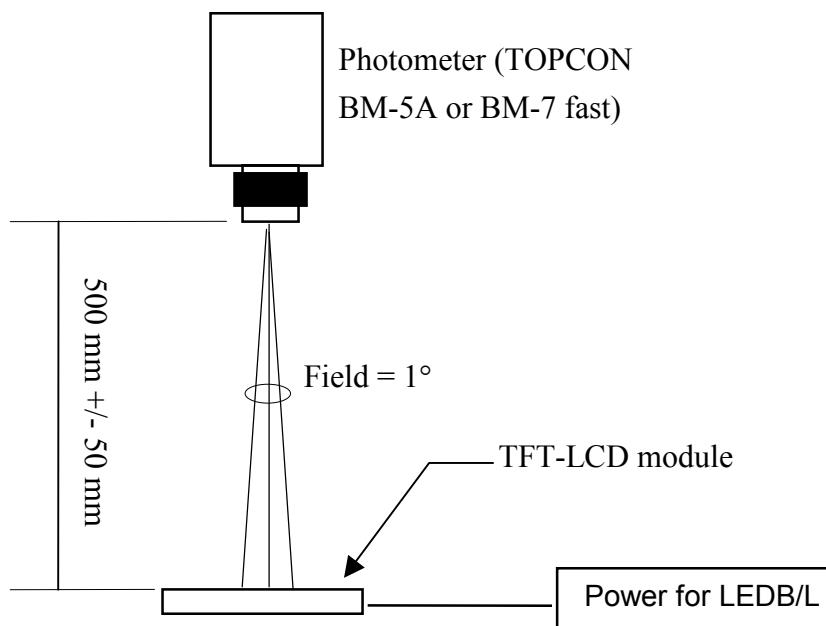

Optical characteristics measuring configuration

Note 91 : The definitions of viewing angles are as follows.

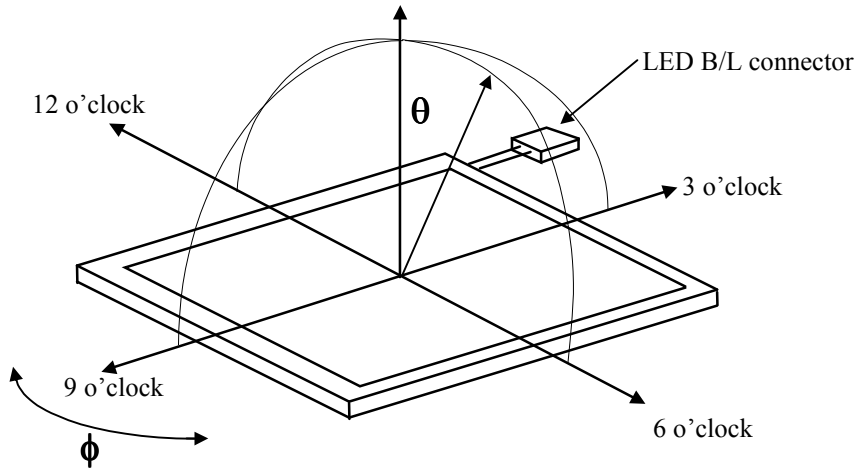

Note 9-2 : The definition of contrast ratio $CR = \frac{\text{Luminance at gray level 63}}{\text{Luminance at gray level 0}}$

Note 9-3: Topcon BM-5A or BM-7 fast luminance meter 1° field of view is used in the testing (after 30 minutes' operation). The typical luminance value is measured at LED current 20mA

Note 9-4: Definition of Response Time T_r and T_f :

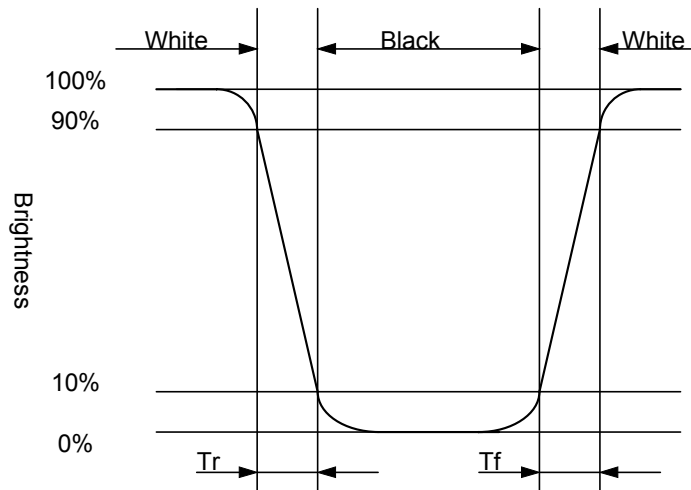

Note 9-5: The uniformity of LCD is defined as

$$U = \frac{\text{The Minimum Brightness of the 9 testing Points}}{\text{The Maximum Brightness of the 9 testing Points}}$$

Luminance meter : BM-5A or BM-7 fast(TOPCON)

Measurement distance : 500 mm +/- 50 mm

Ambient illumination : < 1 Lux

Measuring direction : Perpendicular to the surface of module

The test pattern is white (Gray Level 63).

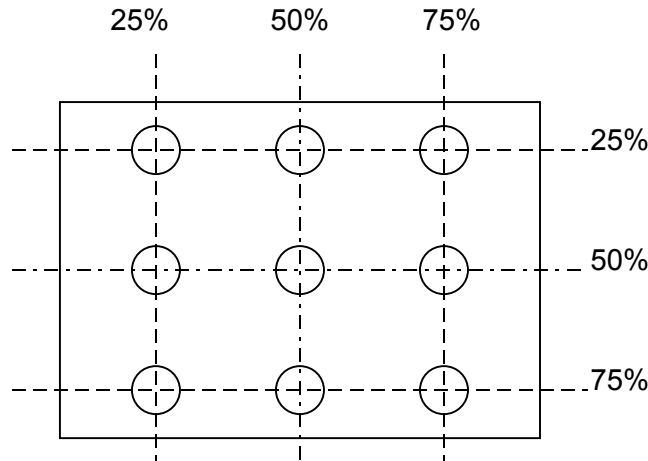

Note 9-6: Cross Talk (CTK) = $\frac{|YA-YB|}{YA} \times 100\%$

YA: Brightness of Pattern A

YB: Brightness of Pattern B

Luminance meter : BM 5A (TOPCON)

Measurement distance : 500 mm +/- 50 mm

Ambient illumination : < 1 Lux

Measuring direction : Perpendicular to the surface of module

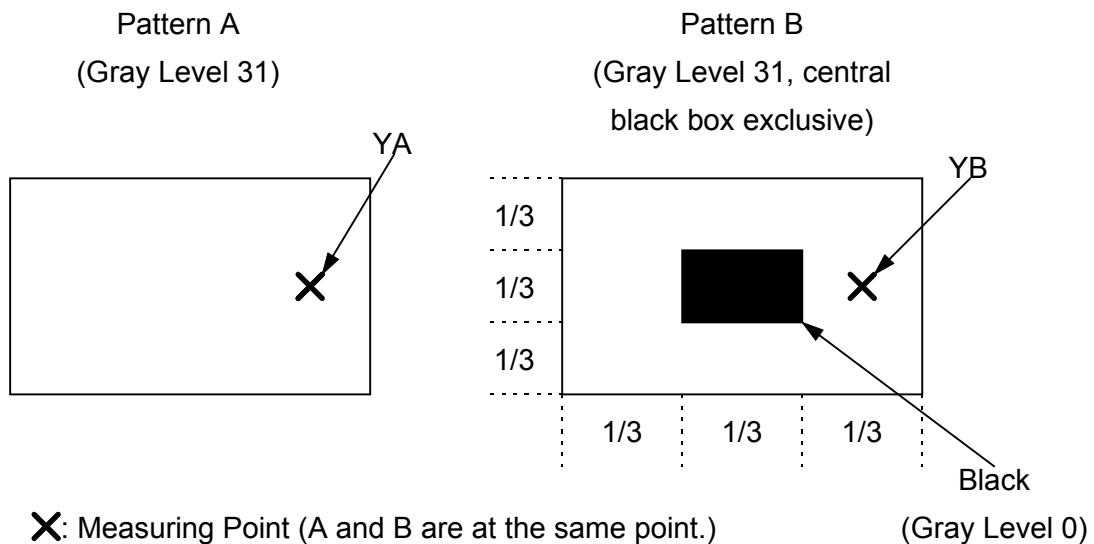

Note 9-7: The "LED Life time " is defined as the module brightness decrease to 50% original Brightness that the ambient temperature is 25°C and I_{LED} =20mA.

10. Handling Cautions**10-1) Mounting of module**

- a) Please power off the module when you connect the input/output connector.
- b) Please connect the ground pattern of the inverter circuit surely. If the connection is not perfect, some following problems may happen possibly.
 - 1. The noise from the backlight unit will increase.
 - 2. The output from inverter circuit will be unstable.
 - 3. In some cases a part of module will heat.
- c) Polarizer which is made of soft material and susceptible to flaw must be handled carefully.
- d) Protective film (Laminator) is applied on surface to protect it against scratches and dirt. It is recommended to peel off the laminator before use and taking care of static electricity.

10-2) Precautions in mounting

- a) When metal part of the TFT-LCD module (shielding lid and rear case) is soiled, wipe it with soft dry cloth.
- b) Wipe off water drops or finger grease immediately. Long contact with water may cause discoloration or spots.
- c) TFT-LCD module uses glass which breaks or cracks easily if dropped or bumped on hard surface. Please handle with care.
- d) Since CMOS LSI is used in the module. So take care of static electricity and earth yourself when handling.

10-3) Adjusting module

- a) Adjusting volumes on the rear face of the module have been set optimally before shipment.
- b) Therefore, do not change any adjusted values. If adjusted values are changed, the specifications described may not be satisfied.

10-4) Others

- a) Do not expose the module to direct sunlight or intensive ultraviolet rays for many hours.
- b) Store the module at a room temperature place.
- c) The voltage of beginning electric discharge may over the normal voltage because of leakage current from approach conductor by to draw lump read lead line around.
- d) If LCD panel breaks, it is possibly that the liquid crystal escapes from the panel. Avoid putting it into eyes or mouth. When liquid crystal sticks on hands, clothes or feet. Wash it out immediately with soap.
- e) Observe all other precautionary requirements in handling general electronic components.
- f) Please adjust the voltage of common electrode as material of attachment by 1 module.

11. Reliability Test

No	Test Item	Test Condition	Remark
1	High Temperature Storage Test	Ta = +70°C, 240 hrs	
2	Low Temperature Storage Test	Ta = -20°C, 240 hrs	
3	High Temperature Operation Test	Ta = +60°C, 240 hrs	
4	Low Temperature Operation Test	Ta = 0°C, 240 hrs	
5	High Temperature & High Humidity Operation Test	Ta = +50°C, 80%RH, 240 hrs (No Condensation)	
6	Thermal Cycling Test (non-operating)	0°C ←→ +60°C, 100 Cycles 1Hr 1Hr	
7	Vibration Test (non-operating)	Frequency : 10 ~ 57 Hz, Amplitude : 0.15 mm 58~500Hz, 1G Sweep time: 11 min Test Period: 3 hrs (1 hr for each direction of X, Y, Z)	
8	Shock Test (non-operating)	80G, 6ms, X,Y, Z 1 times for each direction	
9	Electron Static Discharge	C=150pF,R=330Ω Contact=±8KV Air=±15KV 10 times/terminal	

Ta: ambient temperature

[Criteria]

In the standard conditions, there is not display function NG issue occurred.

(including : line defect ,no image). All the cosmetic specification is judged before the reliability stress.

12. Block Diagram

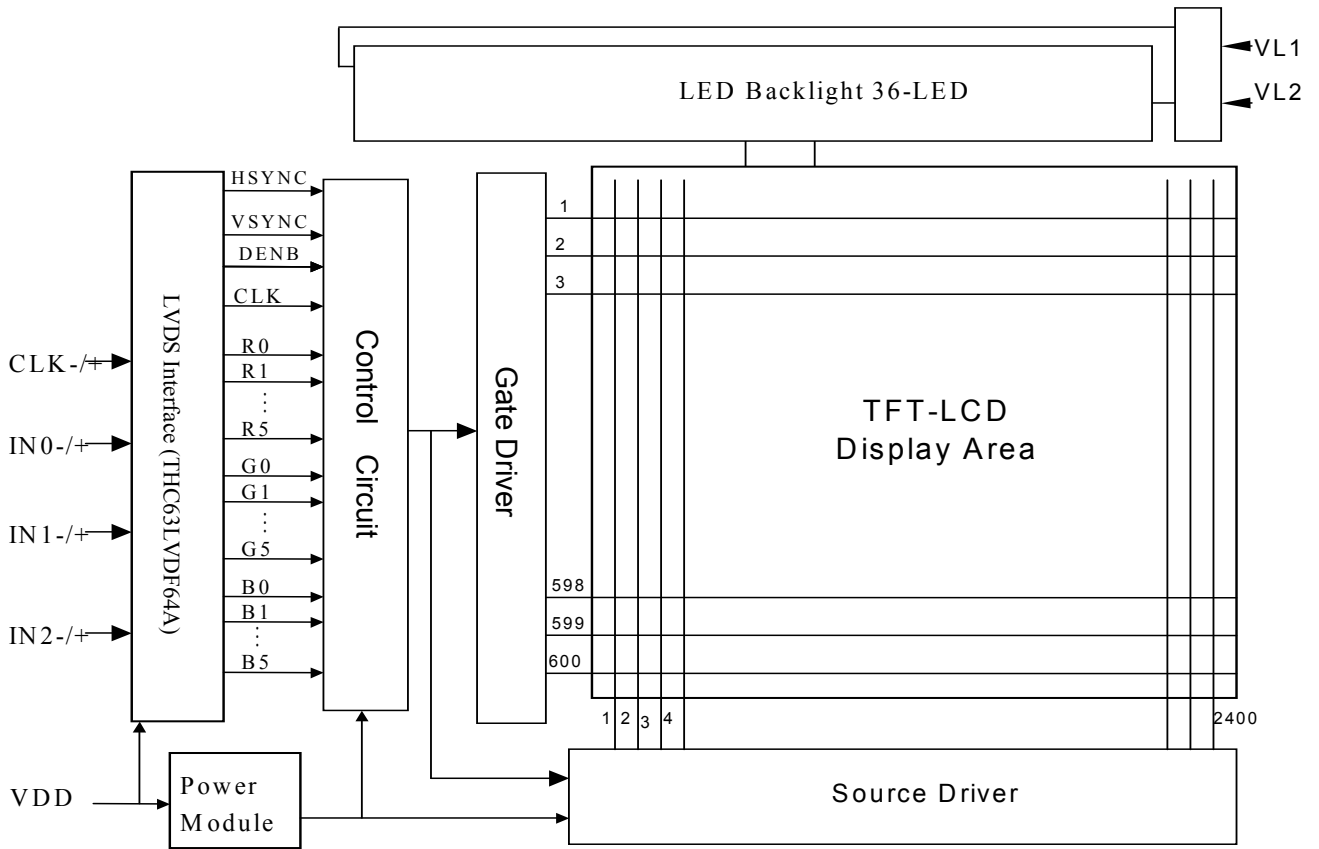

13.Packing

TBD

Revision History

Rev.	Issued Date	Eng.	Revised Content
0.1	Feb.08. 2007	蔡弘毅	New