

MOSFET 70A 450~500V

PD10M441L PD10M440L
P2H10M441L P2H10M440L

PD10M441L/440L

P2H10M441L/440L

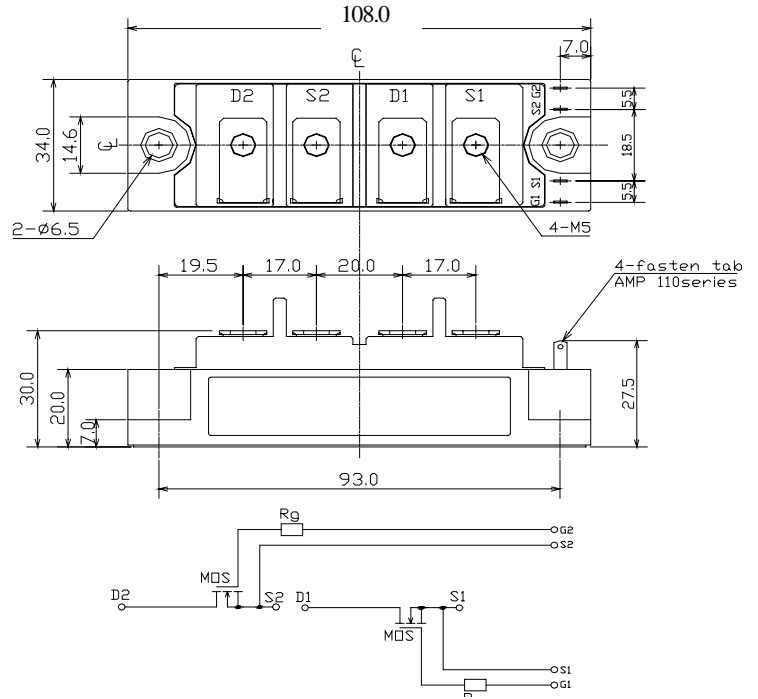
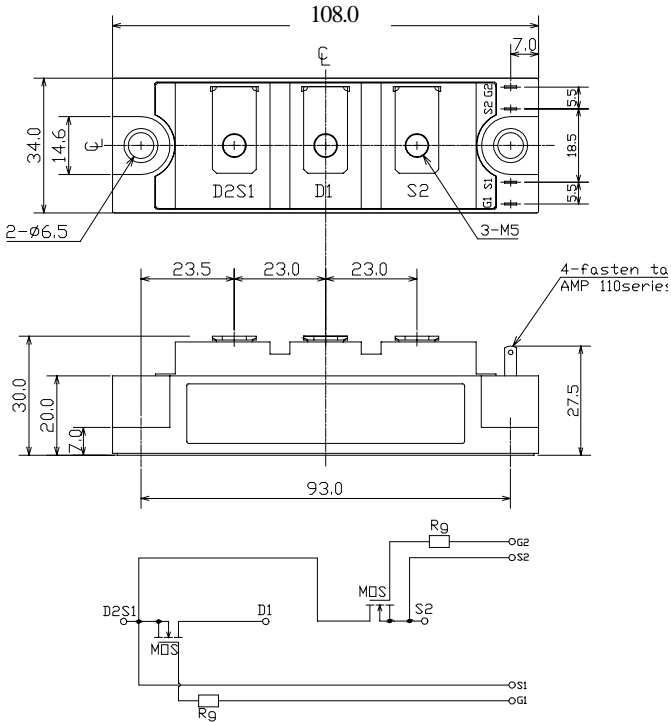

質量 Approximate Weight :220g

質量 Approximate Weight :220g

最大定格 Maximum Ratings

項目 Rating	目	記号 Symbol	耐压・クラス Grade		単位 Unit
			PD10M441L/P2H10M441L	PD10M440L/P2H10M440L	
ドレイン・ソース間電圧 Drain-Source Voltage		V_{DSS}	450	500	V
			$V_{GS}=0V$		
ゲート・ソース間電圧 Gate-Source Voltage		V_{GSS}	± 20		V
ドレイン電流 (連続) Continuous Drain Current	Duty=50%	I_D	70 ($T_c=25$)		A
	D.C.		50 ($T_c=25$)		
パルスドレイン電流 Pulsed Drain Current		I_{DM}	140 ($T_c=25$)		A
全損失 Total Power Dissipation		P_D	500 ($T_c=25$)		W
動作接合温度範囲 Operating Junction Temperature Range		T_{jw}	- 40 ~ +150		
保存温度範囲 Storage Temperature Range		T_{stg}	- 40 ~ +125		
絶縁耐圧 RMS Isolation Voltage		V_{iso}	2000		V
			端子 - ベース間, AC1 分間 Terminals to Base, AC 1 min.		
締付トルク Mounting Torque		F_{tor}	3.0 (本体取付 Module Base to Heat sink)		N・m
			2.0 (ネジ端子部 Bus bar to Main Terminals)		

電気的特性 Electrical Characteristics (@Tc = 25 unless otherwise noted)

項目 Characteristic	記号 Symbol	条件 Condition	特性値 (最大) Maximum Value			単位 Unit
			最小 Min.	標準 Typ.	最大 Max.	
ドレイン遮断電流 Zero Gate Voltage Drain Current	IDSS	VDS = VDSs, VGS = 0V			1	mA
		Tj = 125, VDS = VDSs, VGS = 0V			4	
ゲート・ソース間しきい値電圧 Gate-Source Threshold Voltage	VGS(th)	VDS = VGS, ID = 1mA	2	3.1	4	V
ゲート・ソース間漏れ電流 Gate-Source Leakage Current	IGSS	VGS = ±20V, VDS = 0V			1	μA
ドレイン・ソース間オン抵抗 (MOSFET部) Static Drain-Source On-Resistance	rDS(on)	VGS = 10V, ID = 40A		75	85	m
順伝達コンダクタンス Forward Transconductance	gfg	VDS = 15V, ID = 40A		65		S
入力容量 Input Capacitance	Ciss	VGS = 0V VDS = 25V f = 1MHz		13		nF
出力容量 Output Capacitance	Coss			2.2		nF
帰還容量 Reverse Transfer Capacitance	Crss			0.45		nF
ターン・オン遅延時間 Turn-On Delay Time	t(on)			140		ns
上昇時間 Rise Time	tr	VDD = 1/2VDSs ID = 25A		110		ns
ターン・オフ遅延時間 Turn-Off Delay Time	t(off)	VGS = -5V, +10V RG = 7		300		ns
下降時間 Fall Time	tf			50		ns

内部ダイオード定格・特性 Source-Drain Diode Ratings and Characteristics (@Tc = 25 unless otherwise noted)

項目 Characteristic	記号 Symbol	条件 Condition	特性値 (最大) Maximum Value			単位 Unit
			最小 Min.	標準 Typ.	最大 Max.	
ソース電流 (連続) Continuous Source Current	IS	D. C.			50	A
パルスソース電流 Pulsed Source Current	ISM				140	A
ダイオード順電圧 Diode Forward Voltage	VSD	IS = 70A			2.0	V
逆回復時間 Reverse Recovery Time	trr	IS = 70A		1100		ns
逆回復電荷 Reverse Recovery Charge	QR	- dis/dt = 100A/μs		36		μC

熱抵抗特性 Thermal Characteristics

項目 Characteristic	記号 Symbol	条件 Condition	特性値 (最大) Maximum Value			単位 Unit
			最小 Min.	標準 Typ.	最大 Max.	
熱抵抗 (接合部 - ケース間) Thermal Resistance, Junction to Case	Rth(j-c)	MOSFET			0.25	/W
		Diode			0.25	
接触熱抵抗 (ケース - 冷却フィン間) Thermal Resistance, Case to Heatsink	Rth(c-f)	サーマルコンパウンド塗布 Mounting surface flat, smooth, and greased			0.1	

Fig. 1 Typical Output Characteristics

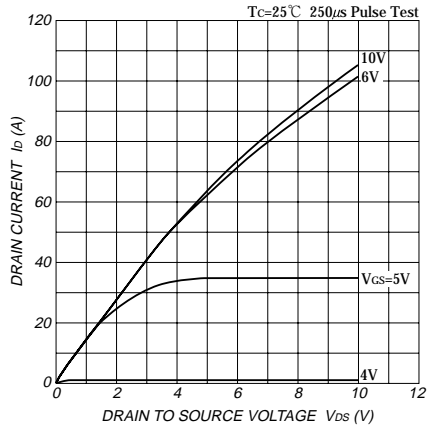

Fig. 4 Typical Capacitance Vs. Drain-Source Voltage

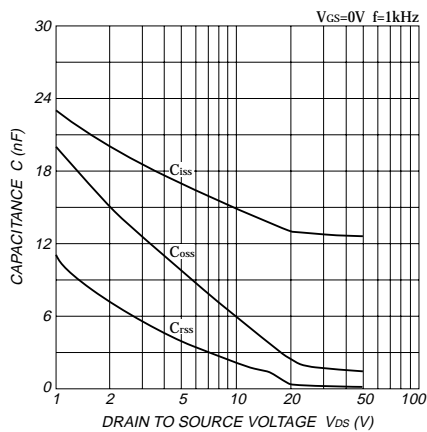

Fig. 7 Typical Switching Time Vs. Drain Current

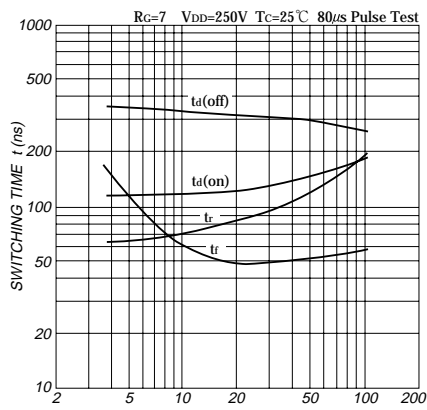

Fig. 10 Maximum Safe Operating Area

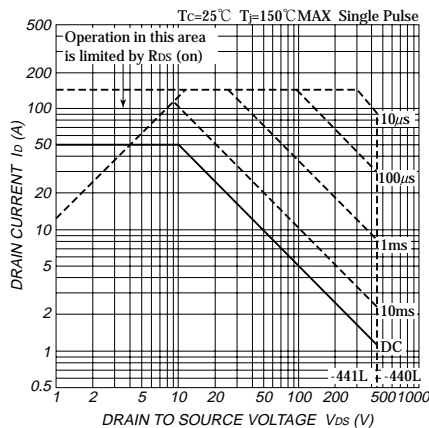

Fig. 2 Typical Drain-Source On-Voltage Vs. Gate-Source Voltage

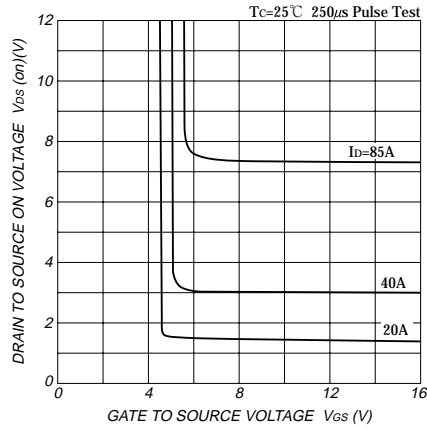

Fig. 5 Typical Gate Charge Vs. Gate-Source Voltage

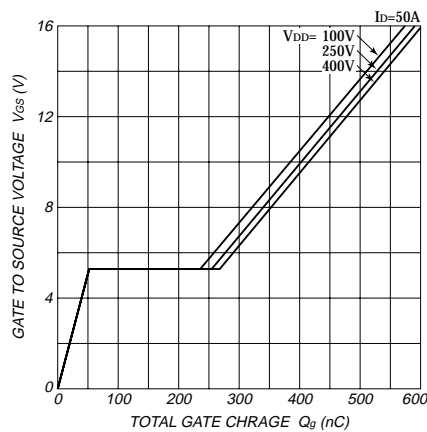

Fig. 8 Typical Source-Drain Diode Forward Characteristics

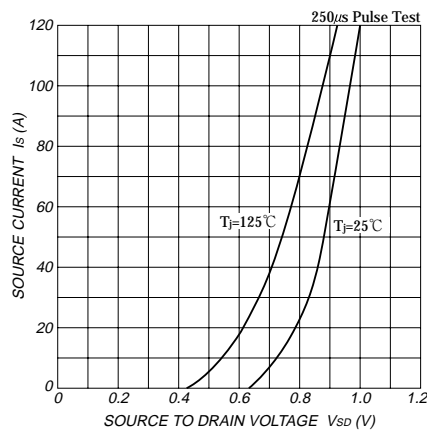

Fig. 11 Normalized Transient Thermal impedance(MOSFET)

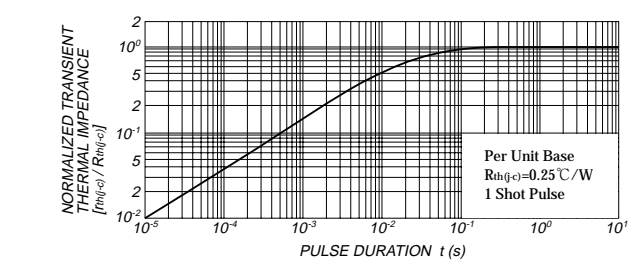

Fig. 3 Typical Drain-Source On Voltage Vs. Junction Temperature

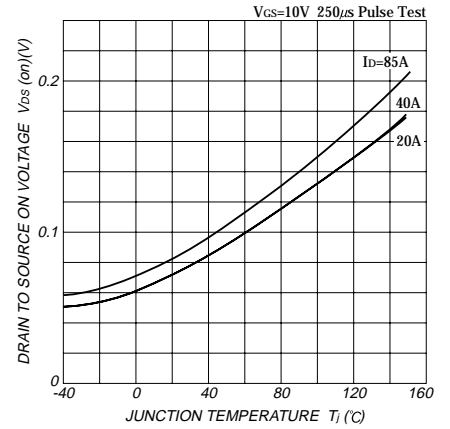

Fig. 6 Typical Switching Time Vs. Series Gate impedance

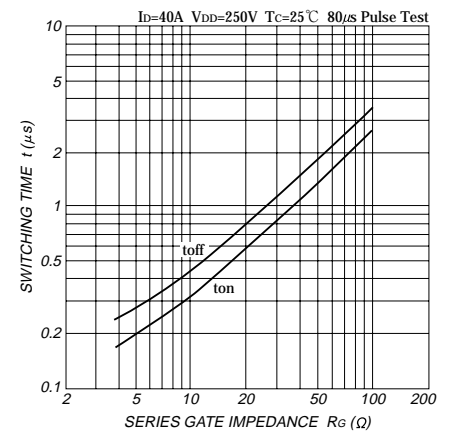

Fig. 9 Typical Reverse Recovery Characteristics

