

Version : 1.0

TECHNICAL SPECIFICATION
MODEL NO : PD121SL1

The content of this information is subject to be changed without notice.
Please contact PVI or its agent for further information.

Customer's Confirmation

Customer _____

Date _____

By _____

PVI's Confirmation

Confirmed By _____

Prepared By _____

Revision History

Rev.	Eng.	Issued Date	Revised Contents
0.1	蔡弘毅	June,23,2006	Preliminary SPEC
0.2	蔡弘毅	July,25,2006	Add 4.Mechanical Drawing of TFT-LCD Module 13. Optical Characteristics: White Variation (typ=1.25 Max=1.4)
0.3	蔡弘毅	Dec.06,2006	Modify outline drawing./RA test condition./ White Chromaticity./Block Diagram
1.0	黃秀晶	June 21,2007	New

TECHNICAL SPECIFICATION

CONTENTS

NO.	ITEM	PAGE
-	Cover	1
-	Revision History	2
-	Contents	3
1	Application	4
2	Features	4
3	Mechanical Specifications	4
4	Mechanical Drawing of TFT-LCD Module	5
5	Input / Output Terminals	7
6	Absolute Maximum Ratings	8
7	Electrical Characteristics	8
8	Pixel Arrangement	10
9	Display Color and Gray Scale Reference	11
10	Block Diagram	12
11	Interface Timing	13
12	Power On Sequence	14
13	Optical Characteristics	15
14	Handling Cautions	18
15	Reliability Test	19
16	Packing Diagram	20

1.Application

The PD121SL1 model is a 12.1" TFT-LCD module with a 2-CCFL Backlight Unit and a 20-pin 1ch-LVDS interface. This module supports 800 x 600 SVGA mode and displays 262,144 colors. The inverter module for the Backlight Unit is not built in.

This module can apply TFT-LCD monitor, TV, Factory application, Amusement Vehicle, and so on.

2. Features

- Wide viewing angle
- High contrast ratio
- Fast response time
- High color saturation
- SVGA (800 x600 pixels) resolution
- Wide operating temperature
- DE (Data Enable) mode
- LVDS (Low Voltage Differential Signaling) interface
- RoHS Compliance
- Reversible-Scan Function

3.Mechanical Specifications

Parameter	Specifications	Unit
Screen Size	12.1 (diagonal)	inch
Display Format	800 ×R, G, B) ×600	dot
Display Colors	262,144	
Active Area	246.00(H) ×184.50(V)	mm
Pixel Pitch	0.3075(H) ×0.3075(V)	mm
Pixel Configuration	Stripe	
Outline Dimension	260.5(W) ×204.0(H) ×12.17(typ.) (D)	mm
Weight	660 ±20	g
Back-light	CCFL, 2 tube	
Surface treatment	Anti-glare & Hard Coating	
Display mode	Normally Black	

4.Mechanical Drawing of TFT-LCD Module

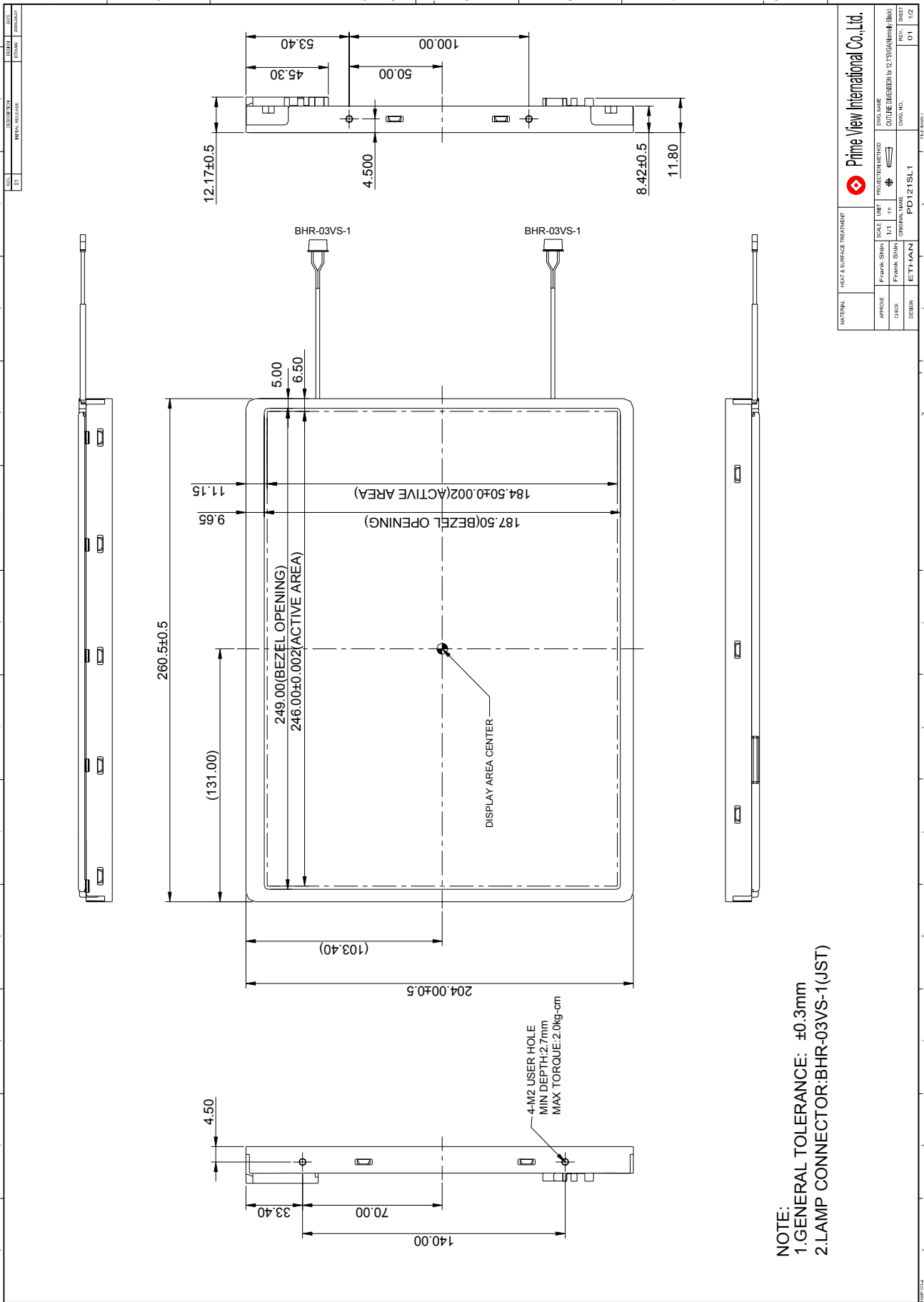

MATERIAL		HEAT & SURFACE TREATMENT		Prime View International Co., Ltd.		DRAW NAME		CUTLINE DIMENSION (UNIT)		PROJ. SHEET	
PROJECT NAME		PROJECT NUMBER		SCALE		UNIT		DRAW NO.		REV. / SHEET	
APPROVE		CHECK		DESIGN		DRAWN		DATE		PAGE	
FRANK SHIN		FRANK SHIN		FRANK SHIN		FRANK SHIN		FRANK SHIN		FRANK SHIN	
1/1		1/1		1/1		1/1		1/1		1/1	
PD121SL1		PD121SL1		PD121SL1		PD121SL1		PD121SL1		PD121SL1	
01		01		01		01		01		01	

NOTE:
 1.GENERAL TOLERANCE: ±0.3mm
 2.LAMP CONNECTOR:BHR-03VS-1(JST)

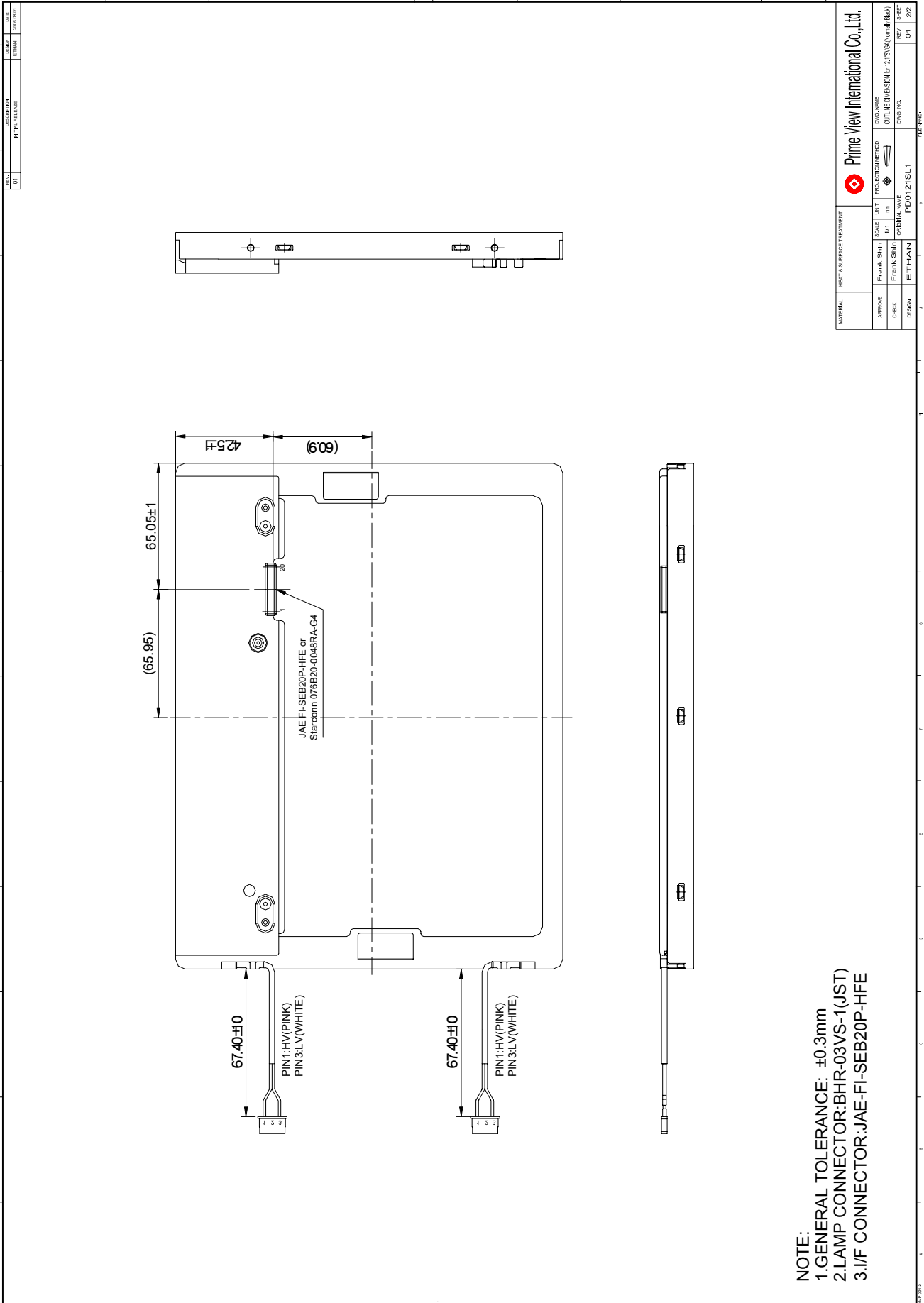

NOTE:
 1. GENERAL TOLERANCE: ±0.3mm
 2. LAMP CONNECTOR: BHR-03VS-1 (JST)
 3. I/F CONNECTOR: JAE-FI-SEB20P-HFE

REV. 01	DATE	BY	CHKD.
01			

MATERIAL		FINISH & SURFACE TREATMENT		Prime View International Co., Ltd.	
APPROVE	FRANK SHIN	SCALE	UNIT	PROJECTION METHOD	DWG. NAME
CHECK	FRANK SHIN	1/1	mm	1st	OUTLINE DRAWING OF JST VS (Bottom) REEL
DESIGN	BETHANN	CORRECTION			DWG. NO.
					PD0121SL1
					REV. SHEET
					01 / 22

5.Input / Output Terminals

5-1) TFT-LCD Panel Driving

Connector type: JAE-FI-SEB20P-HFE or STARCONN 076B20-0048RA-G4

Pin No.	Symbol	Function	Remark
1	Vcc_IN	Power Supply(5.0V/ 3.3V)	
2	Vcc_IN	Power Supply(5.0V/ 3.3V)	
3	GND	Ground	
4	GND	Ground	
5	RXO-	Differential Data Input, CH0 (Negative)	R0~R5,G0
6	RXO+	Differential Data Input, CH0 (Positive)	
7	GND	Ground	
8	RX1-	Differential Data Input, CH1 (Negative)	G1~G5,B0,B1
9	RX1+	Differential Data Input , CH1 (Positive)	
10	GND	Ground	
11	RX2-	Differential Data Input , CH2 (Negative)	B2~B5,DE
12	RX2+	Differential Data Input , CH2 (Positive)	
13	GND	Ground	
14	CLK-	Differential Clock Input (Negative)	LVDS Level clock
15	CLK+	Differential Clock Input (Positive)	
16	GND	Ground	
17	L/R	Horizontal Display Mode Select Signal	Note 5-1
18	U/D	Vertical Display Mode Select Signal	Note 5-1
19	GND	Ground	
20	GND	Ground	

Note 5-1 The definitions U/D & R/L

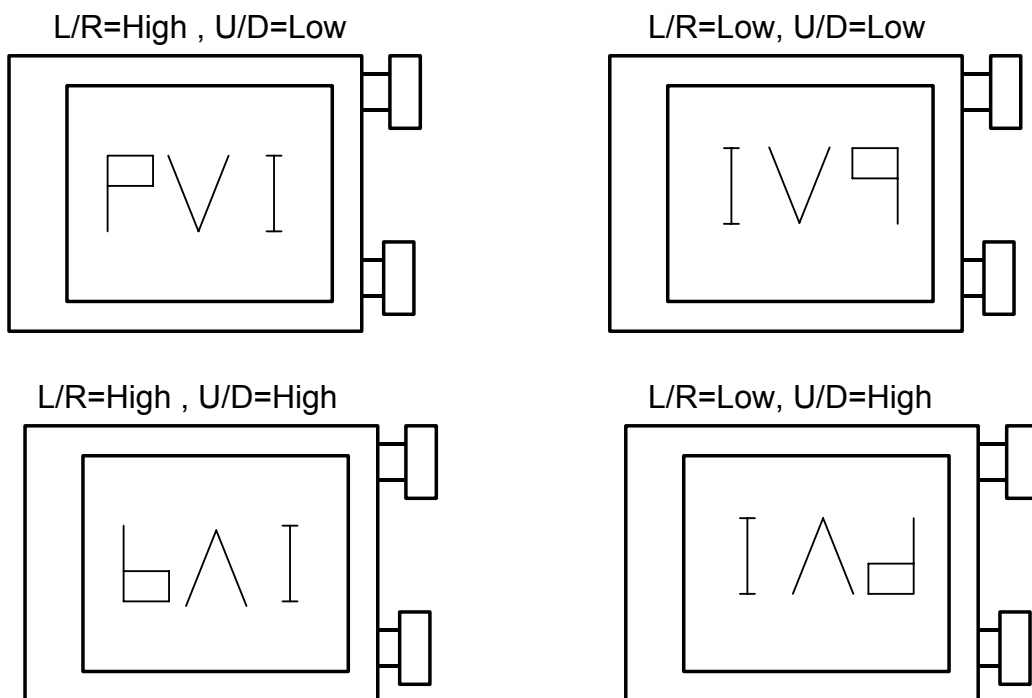

5-2) Backlight driving

Connector Part No.: JST BHR-03VS-1 or equivalent

Pin No	Symbol	Description	Remark
1	HV	Input terminal (Hi voltage side)	Wire color : Pink
2	NA	NA	
3	LV	Input terminal (Low voltage side)	Wire Color : White ,Note 5-2

Note 5-2 : Low voltage side of backlight inverter connects with ground of inverter circuits.

6.Absolute Maximum Ratings:

The followings are maximum values, which if exceeded, may cause faulty operation or damage to the unit.

GND=0V, Ta=25°C

Parameters	Symbol	MIN.	MAX.	Unit	Remark
Supply Voltage	V _{CC}	-0.3	+6.0	V	
Logic input Voltage	V _{in}	-0.3	+2.7	V	Note 6-1

Note 6-1: Permanent damage to the device may occur if maximum values are exceeded. Function operation should be restricted to the conditions described under Normal Operating Conditions.

7.Electrical Characteristics

7-1) Recommended Operating Conditions:

Ta=25 ± 2°C

Parameter	Symbol	Value			Unit	Note
		Min.	Typ.	Max.		
Power Supply Voltage	V _{CC}	3.0	3.3 / 5.0	5.5	V	-
Ripple Voltage	V _{RP}	-	-	100	mV	-
Rush Current	I _{RUSH}	-	-	Note 6-1	A	Note 7-2
Power Supply Current	White	-	800	-	mA	Note 7-3
	Black	-	440	-	mA	Note 7-3
LVDS differential voltage	V _{id}	-100	-	+100	mV	
LVDS common input voltage	V _{ic}	-	1.2	-	V	

Note 7-1 The module is recommended to operate within specification ranges listed above for normal function.

Note 7-2 Measurement Conditions:

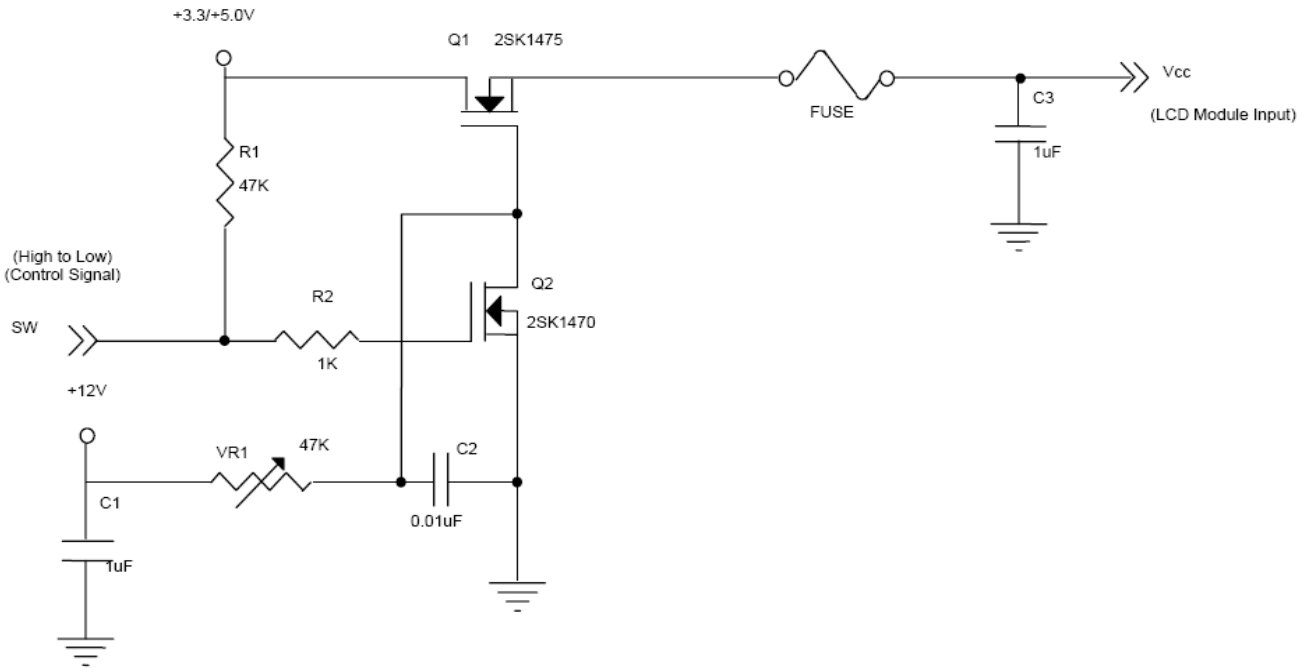

Vcc rising time is 470s

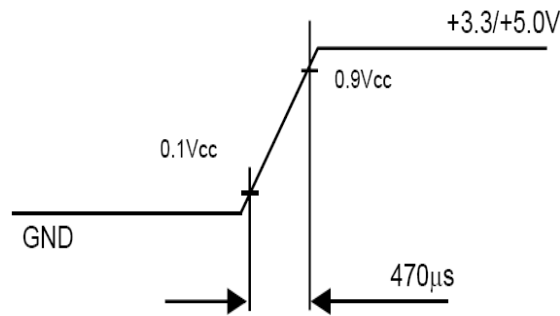

Note 7-3 : The specified power supply current is under the conditions at $V_{cc} = 5.0 \text{ V}$, $T_a = 25 \pm 2^\circ\text{C}$, $f_v = 60 \text{ Hz}$, where as a power dissipation check pattern below is displayed.

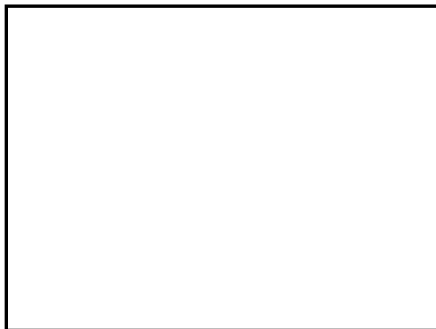

a. White Pattern

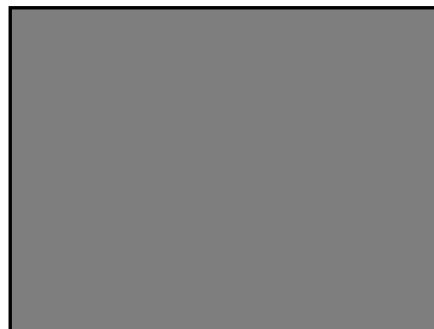

b. Black Pattern

PD121SL1

7-2) Recommended Driver Condition for Backlight

Ta=25°C

Item	Symbol	Min.	Typ.	Max.	Unit	Remark
Lamp Current	I_L	2.0	8.0	8.5	mA	Note 7-4
Lamp Voltage	V_L	450	500	550	Vrms	$I_L=8mA$
Lamp frequency	F	45	-	80	KHz	Note 7-5
Power Consumption	P_L	-	4.0	-	W	Note 7-6
Starting voltage(25°C) (Reference Value)	V_S	-	-	1010	Vrms	Note 7-7
Starting voltage(0°C) (Reference Value)	V_S	-	-	1200	Vrms	Note 7-7

Note 7-4 : In order to satisfy the quality of B/L , no matter use what kind of inverter , the output lamp current must between Min. and Max. to avoid the abnormal display image caused by B/L.

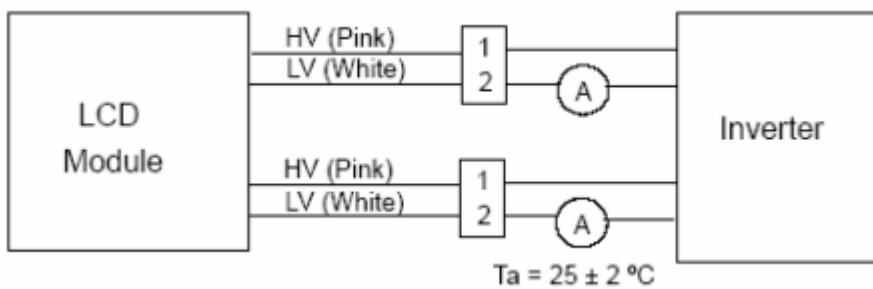

Note 7-5: The lamp frequency may produce interference with horizontal synchronization frequency from the display, which might cause line flow on the display. In order to avoid interference, the lamp frequency should be detached from the horizontal synchronization frequency and its harmonics as far as possible.

Note 7-6 :Backlight lamp power consumption is calculated by $I_L \times V_L$.

Note 7-7 : The " Max of starting voltage " means the minimum voltage of inverter to turn on the CCFL. and it should be applied to the lamp for more than 1 second to start up. Otherwise the lamp may not be turned on.

8. Pixel Arrangement

The LCD module pixel arrangement is the stripe.

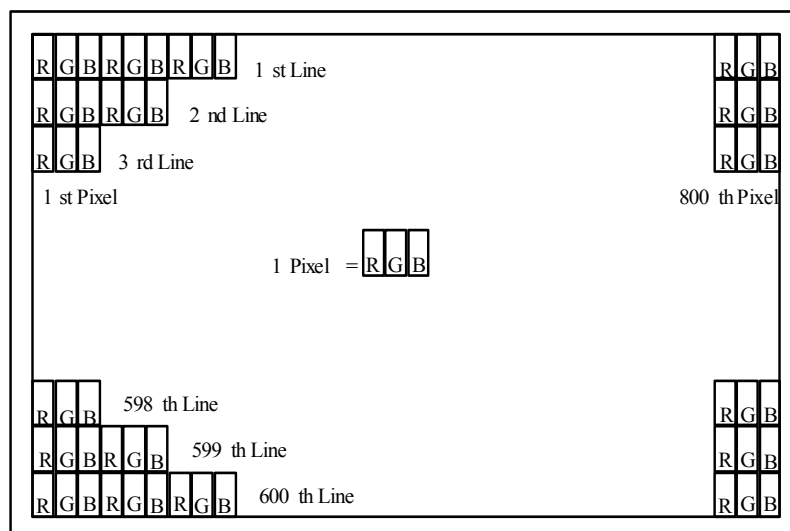

9. Display Color and Gray Scale Reference

Color		Data Signal																	
		Red						Green						Blue					
		R5	R4	R3	R2	R1	R0	G5	G4	G3	G2	G1	G0	B5	B4	B3	B2	B1	B0
Basic Colors	Black	0	0	0	0	0	0	0	0	0	0	0	0	0	0	0	0	0	0
	Red	1	1	1	1	1	1	0	0	0	0	0	0	0	0	0	0	0	0
	Green	0	0	0	0	0	0	1	1	1	1	1	1	0	0	0	0	0	0
	Blue	0	0	0	0	0	0	0	0	0	0	0	0	1	1	1	1	1	1
	Cyan	0	0	0	0	0	0	1	1	1	1	1	1	1	1	1	1	1	1
	Magenta	1	1	1	1	1	1	0	0	0	0	0	0	1	1	1	1	1	1
	Yellow	1	1	1	1	1	1	1	1	1	1	1	1	0	0	0	0	0	0
	White	1	1	1	1	1	1	1	1	1	1	1	1	1	1	1	1	1	1
Gray Scale Of Red	Red(0)/Dark	0	0	0	0	0	0	0	0	0	0	0	0	0	0	0	0	0	0
	Red(1)	0	0	0	0	0	1	0	0	0	0	0	0	0	0	0	0	0	0
	Red(2)	0	0	0	0	1	0	0	0	0	0	0	0	0	0	0	0	0	0
	:	:	:	:	:	:	:	:	:	:	:	:	:	:	:	:	:	:	:
	:	:	:	:	:	:	:	:	:	:	:	:	:	:	:	:	:	:	:
	:	:	:	:	:	:	:	:	:	:	:	:	:	:	:	:	:	:	:
	Red(61)	1	1	1	1	0	1	0	0	0	0	0	0	0	0	0	0	0	0
	Red(62)	1	1	1	1	1	0	0	0	0	0	0	0	0	0	0	0	0	0
Red(63)	1	1	1	1	1	1	0	0	0	0	0	0	0	0	0	0	0	0	
Gray Scale Of Green	Green(0)/Dark	0	0	0	0	0	0	0	0	0	0	0	0	0	0	0	0	0	0
	Green(1)	0	0	0	0	0	0	0	0	0	0	1	0	0	0	0	0	0	0
	Green(2)	0	0	0	0	0	0	0	0	0	0	1	0	0	0	0	0	0	0
	:	:	:	:	:	:	:	:	:	:	:	:	:	:	:	:	:	:	:
	:	:	:	:	:	:	:	:	:	:	:	:	:	:	:	:	:	:	:
	:	:	:	:	:	:	:	:	:	:	:	:	:	:	:	:	:	:	:
	Green(61)	0	0	0	0	0	0	1	1	1	1	0	1	0	0	0	0	0	0
	Green(62)	0	0	0	0	0	0	1	1	1	1	1	0	0	0	0	0	0	0
Green(63)	0	0	0	0	0	0	1	1	1	1	1	1	0	0	0	0	0	0	
Gray Scale Of Blue	Blue(0)/Dark	0	0	0	0	0	0	0	0	0	0	0	0	0	0	0	0	0	0
	Blue(1)	0	0	0	0	0	0	0	0	0	0	0	0	0	0	0	0	0	1
	Blue(2)	0	0	0	0	0	0	0	0	0	0	0	0	0	0	0	0	1	0
	:	:	:	:	:	:	:	:	:	:	:	:	:	:	:	:	:	:	:
	:	:	:	:	:	:	:	:	:	:	:	:	:	:	:	:	:	:	:
	:	:	:	:	:	:	:	:	:	:	:	:	:	:	:	:	:	:	:
	Blue(61)	0	0	0	0	0	0	0	0	0	0	0	0	1	1	1	1	0	1
	Blue(62)	0	0	0	0	0	0	0	0	0	0	0	0	1	1	1	1	1	0
Blue(63)	0	0	0	0	0	0	0	0	0	0	0	0	1	1	1	1	1	1	

Note 9-1: 0: Low Level Voltage, 1: High Level Voltage

10. Block Diagram

10-1) TFT-module Block Diagram

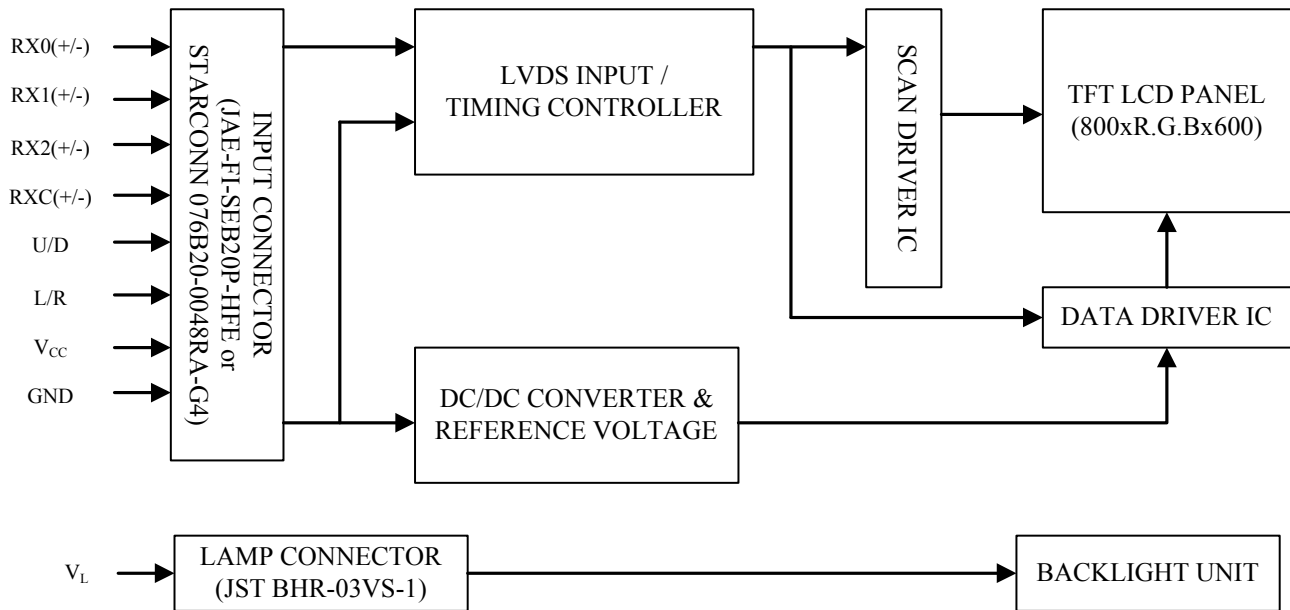

11 Interface Timing

11-1) Timing Parameters

Signal	Item	Symbol	Min.	Typ.	Max.	Unit	Note
LVDS Clock	Frequency	Fc	33.4	39.7	48.3	MHz	-
	Period	Tc	20.7	25.1	29.9	ns	
Vertical Active Display Term	Frame Rate	Fr	56	60	75	Hz	Tv=Tvd+Tvb
	Total	Tv	606	628	650	Th	-
	Display	Tvd	600	600	600	Th	-
	Blank	Tvb	Tv-Tvd	28	Tv-Tvd	Th	-
Horizontal Active Display Term	Total	Th	920	1056	1240	Tc	Th=Thd+Thb
	Display	Thd	800	800	800	Tc	-
	Blank	Thb	Th-Thd	256	Th-Thd	Tc	-

Note11-1 : Because this module is operated by DE only mode, Hsync and Vsync input signals should be set to low logic level or ground. Otherwise, this module would operate abnormally.

INPUT SIGNAL TIMING DIAGRAM

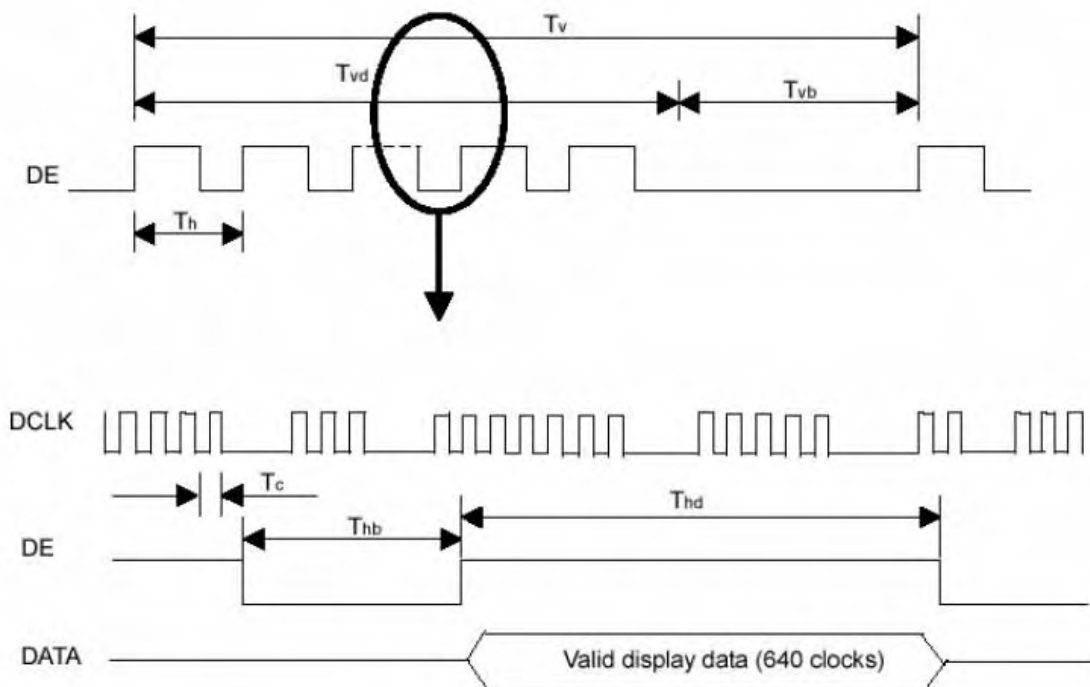

12. Power On Sequence

To prevent a latch-up or DC operation of LCD module, the power on/off sequence should follow the conditions shown in the following diagram.

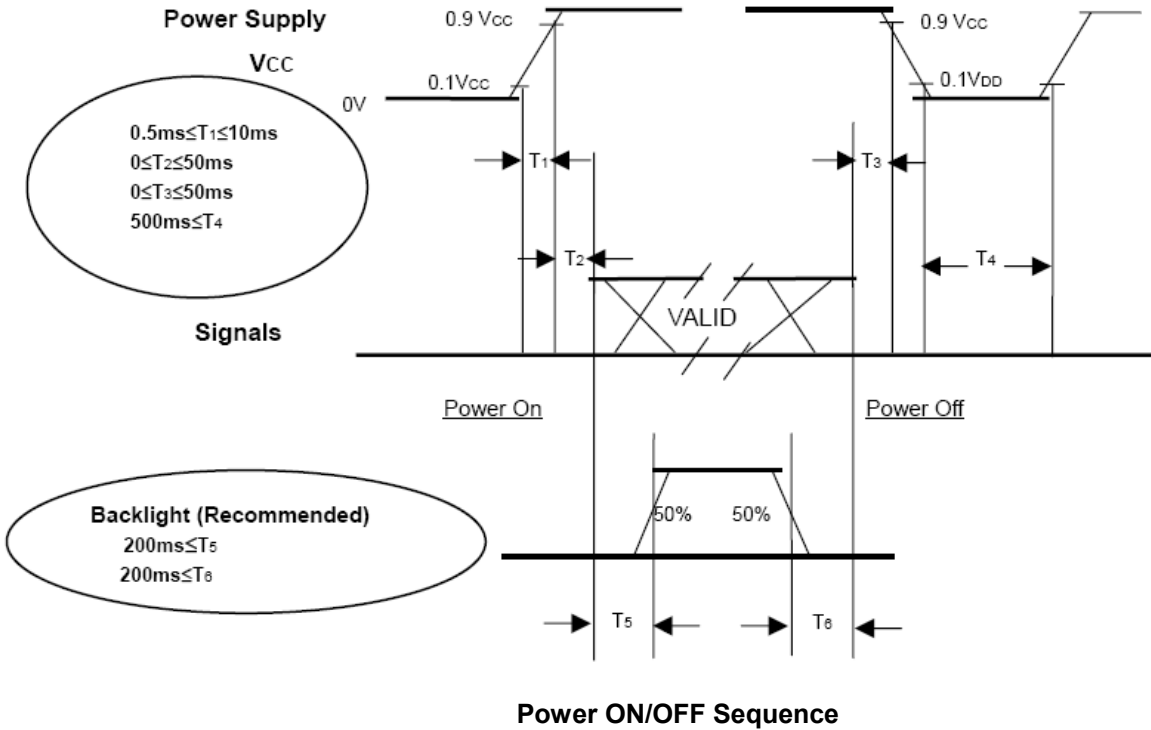

Note 12-1 Please avoid floating state of interface signal at invalid period.

Note 12-2 When the interface signal is invalid, be sure to pull down the power supply of LCD Vcc to 0 V.

Note 12-3 The Backlight inverter power must be turned on after the power supply for the logic and the interface signal is valid. The Backlight inverter power must be turned off before the power supply for the logic and the interface signal is invalid.

13. Optical Characteristics

13-1) Specification:

Ta=25°C

Parameter	Symbol	Condition	MIN.	TYP.	MAX.	Unit	Remarks
Viewing Angle	Horizontal	θ 21.22	80	89	-	deg	Note 13-2
	Vertical	θ 12 (12 o'clock)	80	89	-	deg	
		θ 11 (6 o'clock)	80	89	-	deg	
Contrast Ratio	CR	$\theta = 0^\circ$	700	1000	-	-	Note 13-4
Response time	Rise	Tr	-	13	18	ms	Note 13-3
	Fall	Tf	-	12	17	ms	
Brightness	L	$\theta = 0^\circ / \phi = 0$	380	450	-	cd/m ²	Note 13-1
Lamp Life Time	-	-	50000	-	-	hr	At 8mA
White Chromaticity	x	$\theta = 0^\circ / \phi = 0$	0.296	0.326	0.356	-	
	y	$\theta = 0^\circ / \phi = 0$	0.31	0.340	0.37	-	
White Variation	W	-	-	1.25	1.4	-	Note 13-5

All the optical measurement shall be executed 30 minutes after backlight being turn-on. The optical characteristics shall be measured in dark room (ambient illumination on panel surface less than 1 Lux). The measuring configuration shows as following figure.

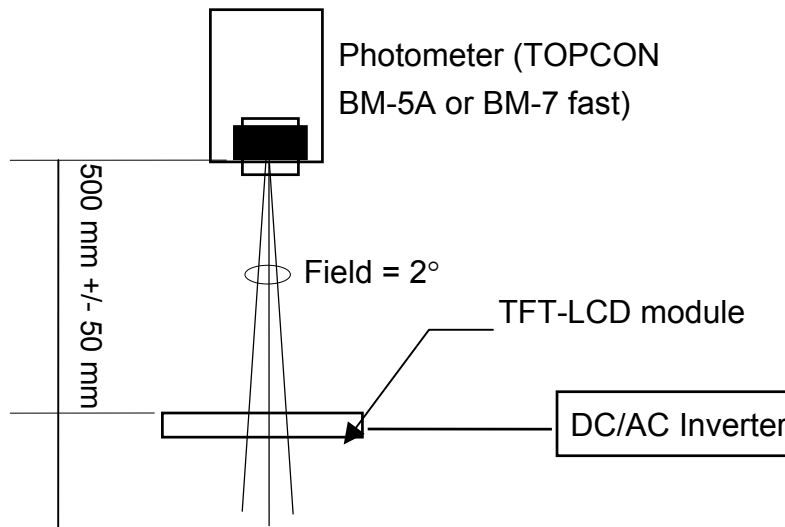

Optical characteristics measuring configuration

Note 13-1: Topcon BM-5A or BM-7 fast luminance meter 2° field of view is used in the testing (after 30 minutes' operation). The typical luminance value is measured at lamp current 8.0 mA.

Note 13-2: The definitions of viewing angles are as follow

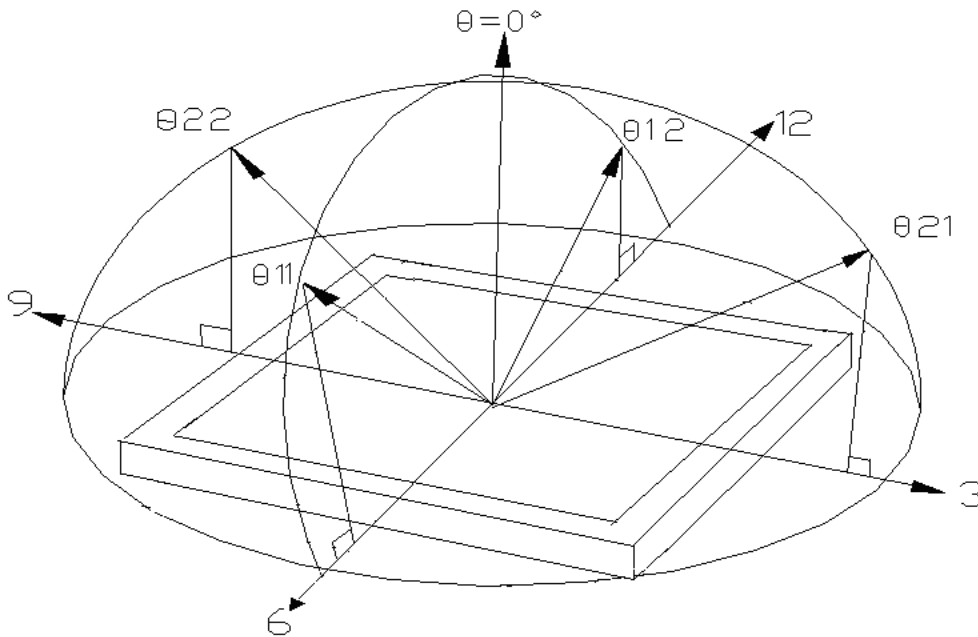

Note 13-3: Definition of Response Time Tr and Tf

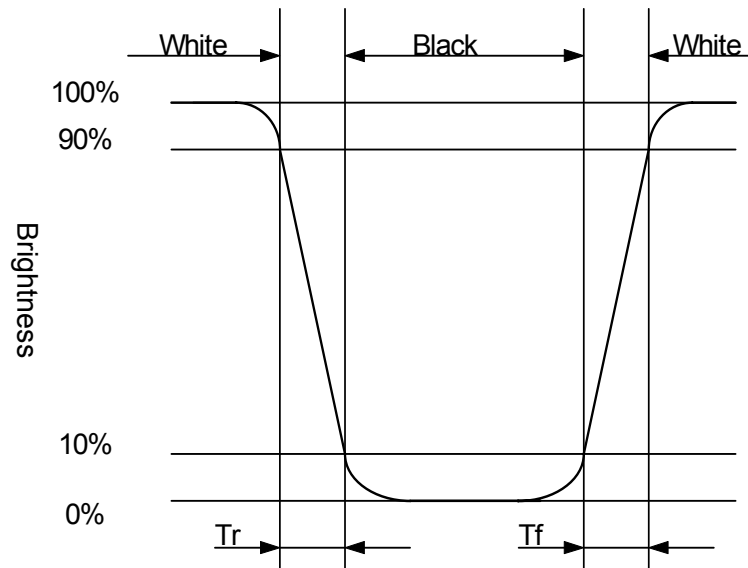

Note 13-4: The definition of contrast ratio $CR = \frac{\text{Luminance at gray level 63}}{\text{Luminance at gray level 0}}$

Note 13-5: Definition of White Variation (W):

Measure the luminance of gray level 63 at 5 points

$$W = \frac{\text{Maximum [L (1), L (2), L (3), L (4), L (5)]}}{\text{Minimum [L (1), L (2), L (3), L (4), L (5)]}}$$

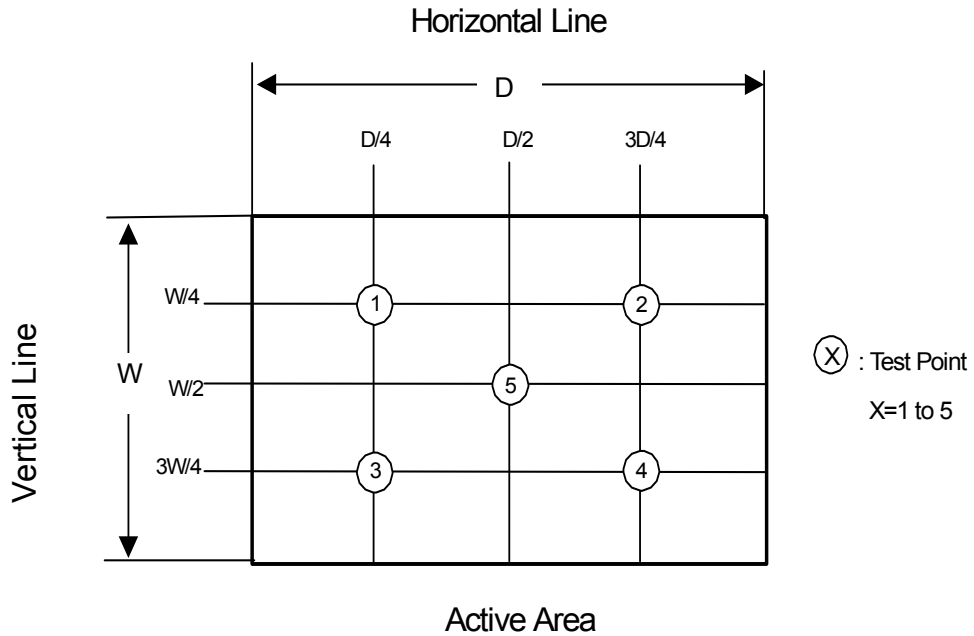

14. Handling Cautions

14-1) Mounting of module

- a) Please power off the module when you connect the input/output connector.
- b) Please connect the ground pattern of the inverter circuit surely. If the connection is not perfect, some following problems may happen possibly.
 - 1.The noise from the backlight unit will increase.
 - 2.The output from inverter circuit will be unstable.
 - 3.In some cases a part of module will heat.
- c) Polarizer which is made of soft material and susceptible to flaw must be handled carefully.
- d) Protective film (Laminator) is applied on surface to protect it against scratches and dirt. It is recommended to peel off the laminator before use and taking care of static electricity.

14-2) Precautions in mounting

- a) When metal part of the TFT-LCD module (shielding lid and rear case) is soiled, wipe it with soft dry cloth.
- b) Wipe off water drops or finger grease immediately. Long contact with water may cause discoloration or spots.
- c) TFT-LCD module uses glass which breaks or cracks easily if dropped or bumped on hard surface. Please handle with care.
- d) Since CMOS LSI is used in the module. So take care of static electricity and earth yourself when handling.

14-3) Adjusting module

- a) Adjusting volumes on the rear face of the module have been set optimally before shipment.
- b) Therefore, do not change any adjusted values. If adjusted values are changed, the specifications described may not be satisfied.

14-4) Others

- a) Do not expose the module to direct sunlight or intensive ultraviolet rays for many hours.
- b) Store the module at a room temperature place.
- c) The voltage of beginning electric discharge may over the normal voltage because of leakage current from approach conductor by to draw lump read lead line around.
- d) If LCD panel breaks, it is possibly that the liquid crystal escapes from the panel. Avoid putting it into eyes or mouth. When liquid crystal sticks on hands, clothes or feet. Wash it out immediately with soap.
- e) Observe all other precautionary requirements in handling general electronic components.
- f) Please adjust the voltage of common electrode as material of attachment by 1 module.

15. Reliability Test

No	Test Item	Test Condition
1	High Temperature Storage Test	Ta = +80°C, 240 hrs
2	Low Temperature Storage Test	Ta = -40°C, 240 hrs
3	High Temperature Operation Test	Ta = +70°C, 240 hrs
4	Low Temperature Operation Test	Ta = -30°C, 240 hrs
5	High Temperature & High Humidity Operation Test	Ta = 60°C, 90%RH, 240 hrs
6	Thermal Cycling Test (non-operating)	-40°C, 0.5hour→+80°C, 0.5hour, 100Cycles,1hr/cycle
7	Vibration Test (non-operating)	5G,10 ~ 300 Hz, 10min/cycle , 3cycles each X, Y, Z
8	Shock Test (non-operating)	200G, 2ms, half sine wave Direction: $\pm X$, $\pm Y$, $\pm Z$ Cycle: 1 time
9	Electrostatic Discharge Test (Operation)	150pF, 330Ω, 1sec/cycle Panel contact $\pm 8KV$ Panel non-contact $\pm 15KV$

Ta: ambient temperature

[Criteria]

In the standard conditions, there is not display function NG issue occurred. (including : line defect ,no image). All the cosmetic specification is judged before the reliability stress.

16. Packing Diagram

ZONE	REV.	DOCUMENT NO.	DESCRIPTION	DATE	REV. BY																														
<p>NOTE:</p> <p>1. Q'TY: 15 pcs panel/carton. 2. Dimension: 465*362*314 mm 3. Weight: 12 Kg</p>																																			
			<table border="1" style="width:100%; border-collapse: collapse;"> <thead> <tr> <th>ITEM</th> <th>PART NO.</th> <th>DESCRIPTION</th> <th>QTY</th> <th>REMARK</th> </tr> </thead> <tbody> <tr> <td>5</td> <td>50-0100291</td> <td>CARTON</td> <td>1</td> <td></td> </tr> <tr> <td>4</td> <td>50-0500301</td> <td>Anti-static Bag</td> <td>15</td> <td>抗靜電</td> </tr> <tr> <td>3</td> <td></td> <td>PD121SL1</td> <td>15</td> <td></td> </tr> <tr> <td>2</td> <td>50-0200100</td> <td>PE FOAM</td> <td>1</td> <td>底座</td> </tr> <tr> <td>1</td> <td>50-0200099</td> <td>PE FOAM</td> <td>2</td> <td>上蓋</td> </tr> </tbody> </table>			ITEM	PART NO.	DESCRIPTION	QTY	REMARK	5	50-0100291	CARTON	1		4	50-0500301	Anti-static Bag	15	抗靜電	3		PD121SL1	15		2	50-0200100	PE FOAM	1	底座	1	50-0200099	PE FOAM	2	上蓋
ITEM	PART NO.	DESCRIPTION	QTY	REMARK																															
5	50-0100291	CARTON	1																																
4	50-0500301	Anti-static Bag	15	抗靜電																															
3		PD121SL1	15																																
2	50-0200100	PE FOAM	1	底座																															
1	50-0200099	PE FOAM	2	上蓋																															
MTL.SPEC.		UNSPECIFIED TOL'S ANGLE ROUGHNESS		REMARK																															
APPROVE	Frank	'06.08.18	SCALE	UNIT	SHEET 1 OF 1																														
CHECK	Frank	'06.08.18	MTL.NO.		DWG.TITLE PD121SL1 Packing Draw																														
DRAWN	Ethan	'06.08.18	DWG FILE:		REV. 01																														
					A4 SIZE																														