

# SUPER INTENSITY VISIBLE LED / INFRARED LED / PHOTO DETECTOR



Stanley super-intensity visible and infrared LEDs (660 nm to 925 nm) are suitable as light sources for optical communications, bar-code readers and sensors. The package of the □□-311, □□-511 and □□-1011 series used for light sourcing and reception can be easily combined with lenses since the position determination accuracy is very high.

## ▼INFRARED LED FOR OPTICAL COMMUNICATIONS USE

Ta=25°C

Type No.	Absolute Maximum Ratings							Electro-Optical Characteristics											fig.
	Power Dissipation	Forward Current	Derating	Peak Forward Current	Reverse Voltage	Operating Temperature	Storage Temperature	Radiant Intensity I <sub>e</sub>			Forward Voltage V <sub>f</sub>		Reverse Current I <sub>r</sub>		Cur-Off Frequency	Wavelength			
	P <sub>d</sub>	I <sub>f</sub>	ΔI <sub>f</sub>	I <sub>fM</sub>	V <sub>r</sub>	T <sub>opr</sub>	T <sub>stg</sub>	MIN.	TYP.	I <sub>e</sub>	TYP.	MAX.	I <sub>r</sub>	MAX.	V <sub>r</sub>	F <sub>c</sub> TYP.	λ <sub>p</sub> TYP.	λ <sub>1/2</sub> TYP.	
FH1011	140	70	0.93	300	4	-30~+85	-30~+100	0.6	1.2	30	2	2.5	30	100	4	7	660	30	
FH511	140	70	0.93	300	4	-30~+85	-30~+100	0.3	0.6	30	1.75	20	30	100	4	7	660	30	
BN511	150	100	1.33	1000	4	-30~+85	-30~+100	0.4	0.8	20	1.2	1.5	20	100	4	1.8	925	50	
DN511	150	100	1.33	1000	5	-30~+85	-30~+100	5	9	50	1.55	2	50	100	5	30	850	40	
KR311	140	70	0.93	300	5	-30~+85	-30~+100	1	1.7	50	2.1	2.5	50	100	5	7	660	30	
DN311	150	100	1.33	1000	5	-30~+85	-30~+100	1	3.5	50	1.55	2	50	100	5	30	850	40	
Units	mW	mA	mA/°C	mA	V	°C	°C	mW/sr	mA	V	mA	μA	V	MHz	nm				

※I<sub>fM</sub> condition: t<sub>w</sub> ≤ 100 μs and duty ≤ 1/100 ※F<sub>c</sub> condition: I<sub>f</sub>=50 mA DC + 10 mAp-p

## ▼PHOTO DETECTOR

•Phototransistor

Ta=25°C

Type No.	Absolute Maximum Ratings						Electro-Optical Characteristics											fig.		
	Collector Dissipation	Collector Breakdown Voltage	Emitter Breakdown Voltage	Collector Current	Operating Temp.	Storage Temp.	Photo Current I <sub>c</sub>				Response Time				Dark Current I <sub>CEO</sub>		Collector Saturation Voltage V <sub>CE</sub>		Peak Sensitive Wavelength λ <sub>p</sub>	
	P <sub>c</sub>	V <sub>CEO</sub>	V <sub>ECO</sub>	I <sub>c</sub>	T <sub>opr</sub>	T <sub>stg</sub>	MIN.	TYP.	V <sub>CE</sub>	E <sub>e</sub>	T <sub>r</sub>	T <sub>f</sub>	V <sub>CE</sub>	I <sub>c</sub>	R <sub>L</sub>	MAX.	V <sub>CEO</sub>		TYP.	I <sub>c</sub>
PS5132	100	30	5	30	-30~+85	-30~+100	2.1	6.3	5	10	5	5	10	2	100	0.2	10	0.1	0.5	880
Units	mW	V	V	mA	°C	°C	mA	V	mW/cm <sup>2</sup>	μsec	V	mA	Ω	μA	V	V	V	mA	nm	

•PIN Photodiode

Type No.	Absolute Maximum Ratings				Electro-Optical Characteristics											fig.		
	Power Dissipation	Reverse Voltage	Operating Temperature	Storage Temperature	Photo Current I <sub>e</sub>			Response Time T <sub>r</sub> -T <sub>f</sub>			Capacitance C <sub>T</sub>			Dark Current I <sub>D</sub>			Peak Sensitive Wavelength λ <sub>p</sub>	
	P <sub>d</sub>	V <sub>r</sub>	T <sub>opr</sub>	T <sub>stg</sub>	TYP.	V <sub>r</sub>	E <sub>e</sub>	TYP.	V <sub>r</sub>	R <sub>L</sub>	TYP.	V <sub>r</sub>	f	MAX.	V <sub>r</sub>		TYP.	V <sub>r</sub>
PP513F	30	30	-30~+85	-30~+100	2.9	5	5	1.4	30	50	20	10	1	10	10	950	0	3
Units	mW	V	°C	°C	μA	V	mW/cm <sup>2</sup>	nsec	V	Ω	pF	V	MHz	μA	V	nm	V	

※A standard tungsten filament lamp with 2.856K is used for the color temperature.

## ▼PACKAGE DIMENSIONS Unit : mm

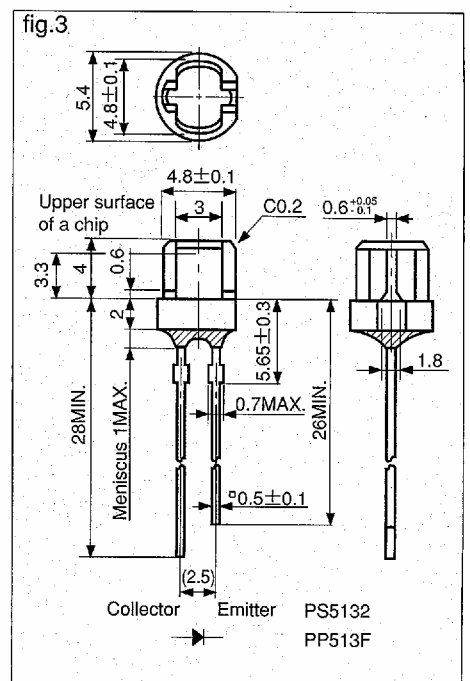
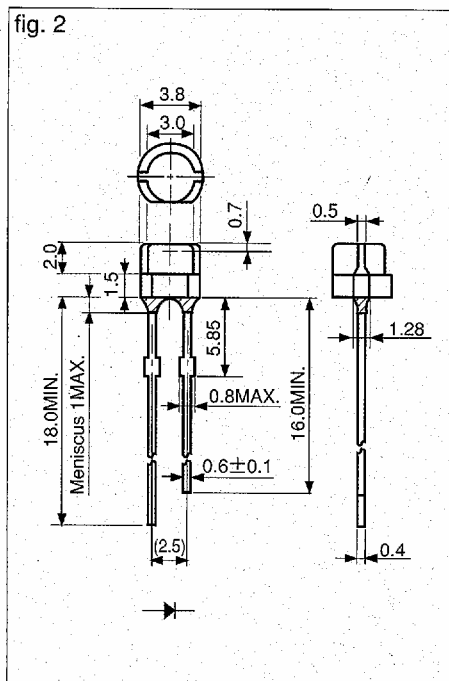
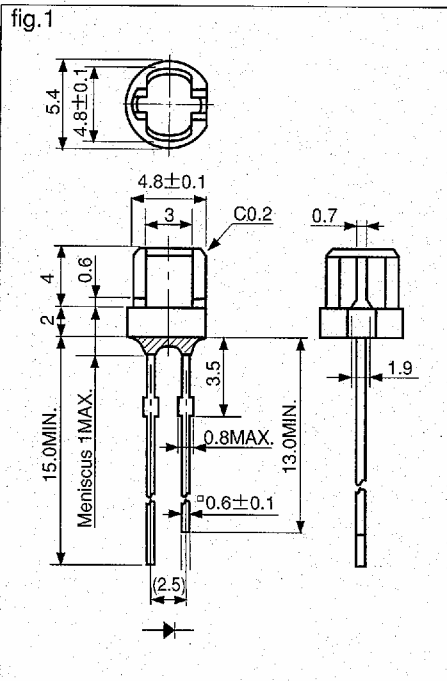

# SUPER INTENSITY INFRARED LED

Stanley's infrared LEDs feature the high intensity / high speed DN series. Four wavelengths(850, 880, 925 and 950) are available in a variety of package sizes to accommodate any design requirement matched with one of our phototransistors or pin photodiodes the ideal source-receiver combination can be achieved.

## ▼CHARACTERISTICS BY MATERIAL

Ta=25°C

Type No.	Shape	Material	Absolute Maximum Ratings						Operating Temperature	Storage Temperature
			Power Dissipation	Forward Current	Derating	Peak Forward Current	Reverse Voltage	Operating Temperature		
	Type		Pd	If	IF	Ifm *	Vr	Topr	Tstg	
AN	501	GaAs	75	50	0.67	500	5	-30~+85	-30~+100	
	TO-18		150	100	1.0	1000		-40~+125	-55~+125	
BN	501	GaAs	60	40	0.53	500	4	-30~+85	-30~+100	
	TO-18		100	50	0.67	1000		-40~+125	-55~+125	
CN	501	GaAlAs	75	50	0.67	500	5	-30~+85	-30~+100	
	TO-18		150	100	1.0	1000		-40~+125	-55~+125	
DN	501	GaAlAs	150	50	0.67	500	5	-30~+85	-30~+100	
	TO-18		150	100	1.0	1000		-40~+125	-55~+125	
Units			mW	mA	mA/°C	mA	V	°C	°C	

Ta=25°C

Type No.	Electro-Optical Characteristics											
	Forward Voltage V <sub>f</sub>		Reverse Current I <sub>r</sub>			Peak Wavelength λ <sub>p</sub> TYP	Wavelength Spectral Half Width Δλ TYP		Cut-Off Frequency F <sub>c</sub> *		Response Time T <sub>r</sub> , T <sub>f</sub>	
	TYP	MAX	I <sub>r</sub>	MAX	V <sub>R</sub>		I <sub>r</sub>	I <sub>r</sub>	TYP	I <sub>r</sub>	TYP	I <sub>r</sub>
AN	1.3	1.5	50	10	5	950	45	50	0.5	50	700	50
BN	1.2	1.5	20	10	4	925	50	20	1.8	20	200	20
CN	1.45	1.8	50	10	5	880	65	50	0.65	50	500	50
DN	1.55	2.0	50	100	5	850	40	50	30	50	10	50
Units		V	mA	μA	V	nm	nm	mA	MHz	mA	nsec	nA

\*I<sub>FM</sub> condition tw ≤ 100 μs, Duty ≤ 1/100

\*F<sub>c</sub> condition I<sub>r</sub> = 50 mAdc + 10 mAp-p (AN, CN, DN), I<sub>r</sub> = 20 mAdc + 4 mAp-p (BN)

## ▼SPECTRAL DISTRIBUTION

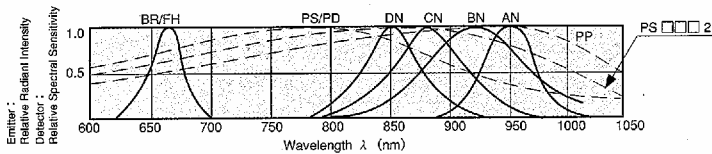

Note for infrared LEDs

Among infrared LEDs, those with CN, DN and NR emit in visible range.

## ▼PACKAGE DIMENSIONS Unit : mm

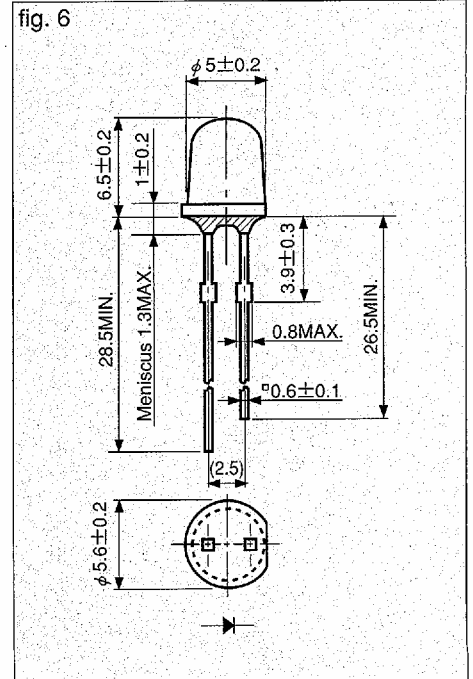
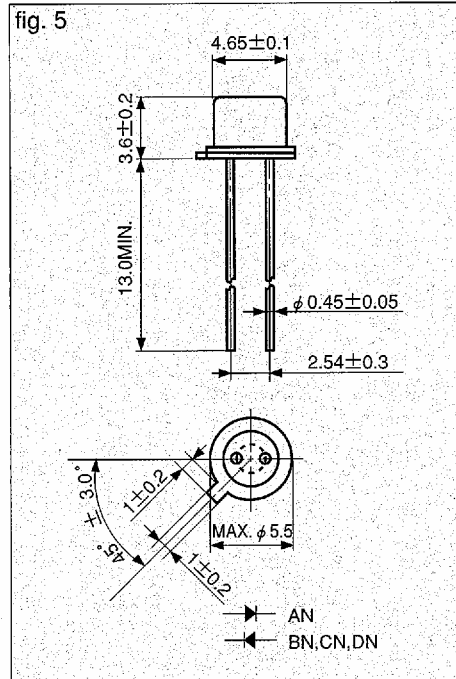
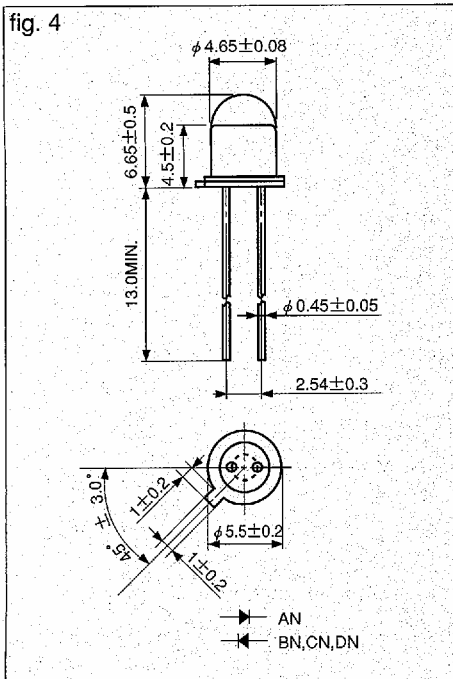

### ▼CHARACTERISTICS BY SHAPE

Ta=25°C

Shape	Type No.	Peak Wavelength λp		Radiant Intensity Ie			Output Power Po		Cut-Off Frequency Fc		Spatial Distribution	fig.
		TYP.	If	MIN.	TYP.	If	TYP.	If	TYP.	If		
	AN106	950	50	15	25	50	3.5	50	0.5	50		4
	BN106	925	20	2.0	4.0	20	—	—	1.8	20		
	CN106	880	50	20	30	50	4.5	50	0.65	50		
	DN106	850	50	25	70	50	7	50	30	50		
	AN202	950	50	1.5	2.5	50	4	50	0.5	50		5
	BN202	925	20	0.15	0.3	20	—	—	1.8	20		
	CN202	880	50	2.0	3.0	50	5	50	0.65	50		
	DN202	850	50	2.5	4.0	50	8	50	30	50		
	AN304	950	50	6	15	50	9	50	0.5	50		6
	CN304	880	50	10	20	50	9	50	0.65	50		
	DN304	850	50	15	30	50	15	50	30	50		
	AN305	950	50	10	25	50	8	50	0.5	50		7
	BN301	925	20	3	7	20	—	—	1.8	20		8
	CN305	880	50	15	30	50	8	50	0.65	50		7
	DN305	850	50	25	80	50	12	50	30	50		
Unit		nm	mA	mW/sr	mA	mW	mA	MHz	mA			

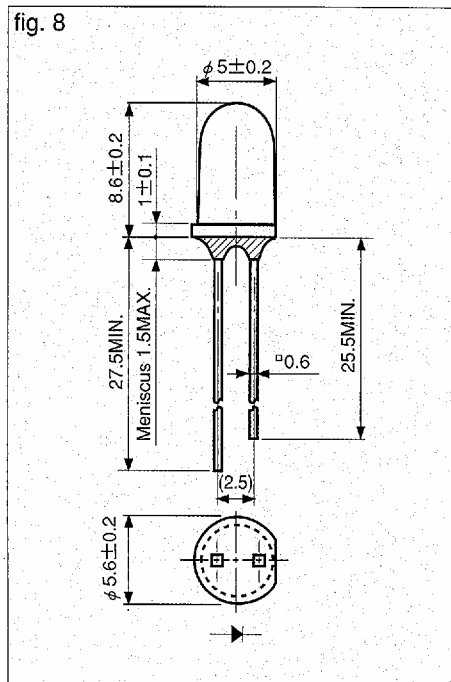
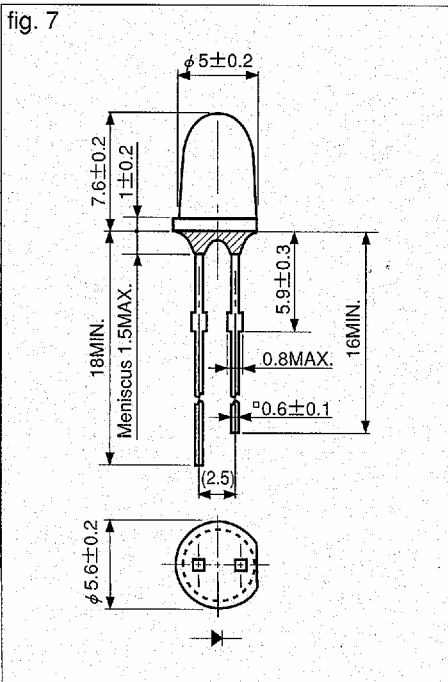

### ▼PACKAGE DIMENSIONS Unit : mm



# SUPER INTENSITY INFRARED LED

## ▼CHARACTERISTICS BY SHAPE

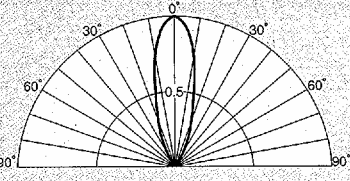
Ta=25°C

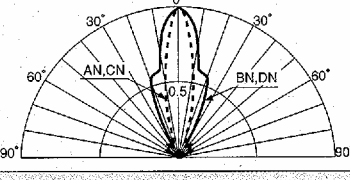
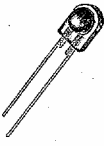
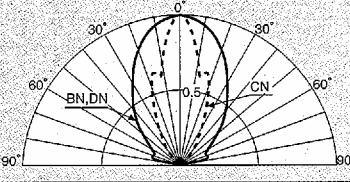
Shape	Type No	Peak Wavelength $\lambda_p$		Radiant intensity $I_E$			Output Power $P_o$		Cut-off Frequency $F_c$		Spatial Distribution	fig.
		TYP	IF	MIN	TYP	IF	TYP	IF	TYP	IF		
	AN306	950	50	7	14	50	5	50	0.5	50		9
	BN306	925	20	1.3	2.6	20	1	20	1.8	20		
	CN306	880	50	9	18	50	7	50	0.65	50		
	DN319	850	50	10	20	50	8	50	30	50		
	AN501	950	50	3	5	50	6	50	0.5	50		11
	BN501	925	20	0.5	1.5	20	—	—	1.8	20		
	CN501	880	50	3	6	50	9	50	0.65	50		
	DN501	850	50	5.2	10.4	50	10	50	30	50		
	BN504	925	20	0.5	1	20	—	—	1.8	20		12
	CN504	880	50	3	5	50	7	50	0.65	50		
	DN504	850	50	4	8	50	12	50	30	50		
Units		nm	nA	mW/sr	mA	mW	mA	MHz	mA			

## ▼PACKAGE DIMENSIONS Unit : mm

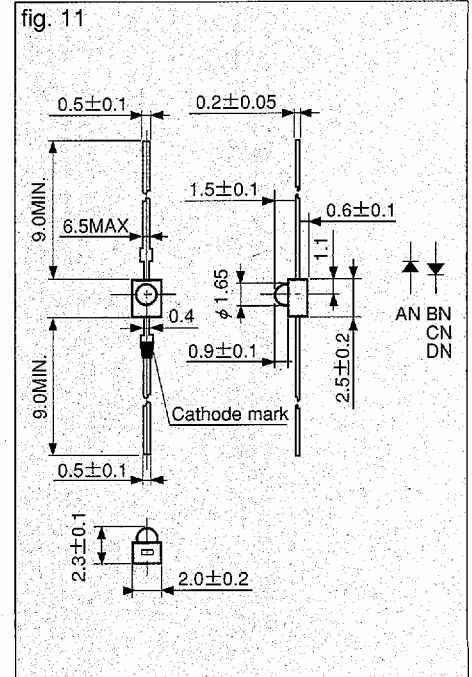
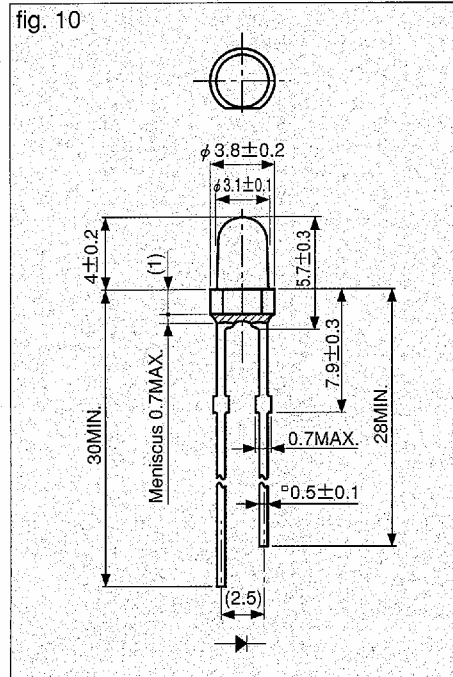
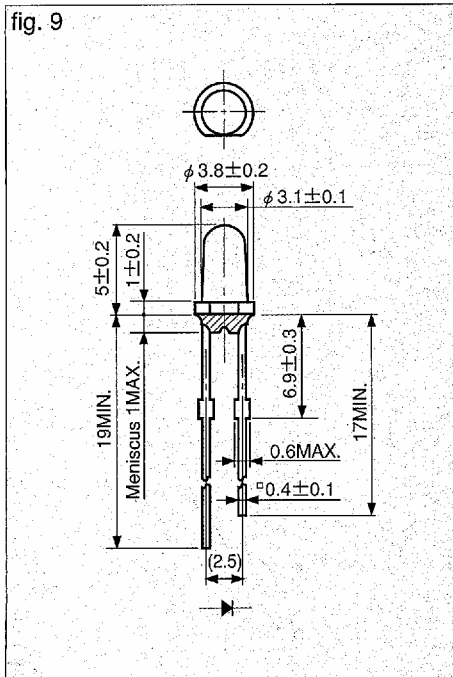

### ▼CHARACTERISTICS BY SHAPE

Ta=25°C

Shape	Type No.	Peak Wavelength λp		Radiant Intensity Ie			Output Power Po			Cut-Off Frequency Fc		Spatial Distribution	fig.
		TYP	IF	MIN	TYP	IF	TYP	IF	TYP	IF			
	AN505	950	50	2	4	50	6	50	0.5	50		13	
	BN505	925	20	0.5	1.5	20	—	—	1.8	20			
	CN505	880	50	2.5	5	50	7	50	0.65	50			
	DN505	850	50	4	8	50	12	50	30	50			
	BN511	925	20	0.4	0.8	20	—	—	1.8	20		1	
	DN511	850	50	5	9	50	12	50	30	50			
	DN311	850	50	1	3.5	50	10	50	30	50		2	
	AN1102W	950	20	0.5	2	20	0.8	20	0.5	20		14	
	DN1102W	850	20	0.8	4	20	1.6	20	30	20			
Units		nm	mA		mW/sr	mA	mW	mA	MHz	mA			

### ▼PACKAGE DIMENSIONS Unit : mm

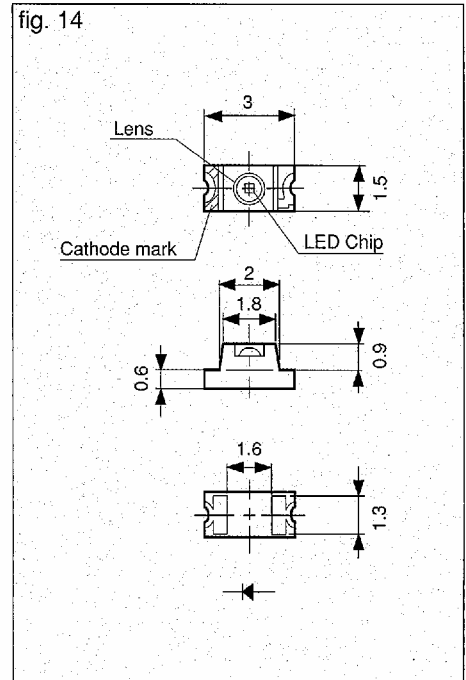
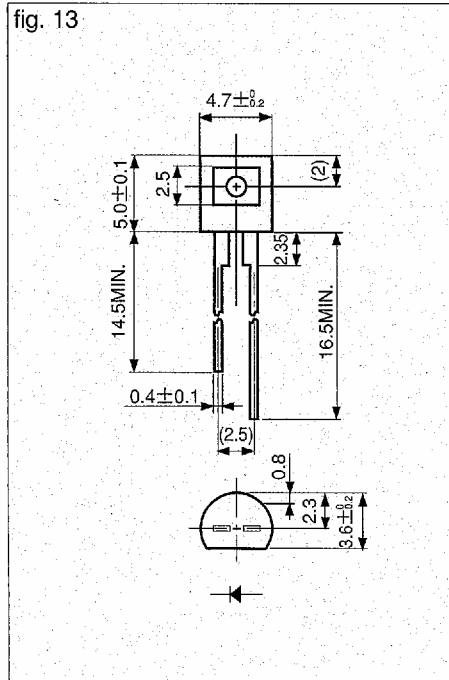
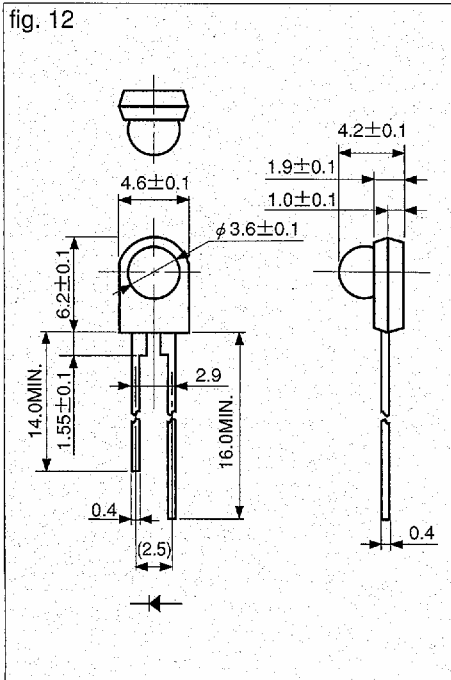



# PHOTOTRANSISTOR

## ▼CHARACTERISTICS BY MATERIAL

Ta=25°C

Type No.	Absolute Maximum Ratings							Electro-Optical Characteristics						
	Collector Dissipation		Collector-Emitter Voltage	Emitter-Base Breakdown Voltage	Collector Current	Operating Temp.	Storage Temp.	Dark Current I <sub>co</sub>		Response Time T <sub>r</sub> , T <sub>f</sub>				Peak Sensitive Wavelength λ <sub>p</sub>
	Type	P <sub>d</sub>	V <sub>ce0</sub>	V <sub>eb0</sub>	I <sub>c</sub>	T <sub>op</sub>	T <sub>stg</sub>	MAX	V <sub>ceF</sub>	TYP	V <sub>ce</sub>	I <sub>c</sub>	R <sub>L</sub>	TYP
PS	TO-18	150	30	5	50	-30~+125	-30~+150	0.2	10	5	10	2	100	800
	502	60			20	-30~+85	-30~+100							
		100			30	-30~+85	-30~+100							
PS	TO-18	150	30	5	50	-30~+125	-30~+150	0.2	10	5	10	2	100	880
	502	60			20	-30~+85	-30~+100							
	□□□ 2	100			30	-30~+85	-30~+100							
PD	TO-18	150	30	5	50	-30~+125	-30~+150	0.2	10	400	10	2	100	800
	502	60			20	-30~+85	-30~+100							
		100			30	-30~+85	-30~+100							
Units		mW	V	V	mA	°C	°C	μA	V	μsec	V	mA	Ω	nm

## ▼CHARACTERISTICS BY SHAPE

Ta=25°C

Shape	Type No.	Features	Peak Sensitive Wavelength λ <sub>p</sub> (TYP)	Photo Current I <sub>c</sub>				Spatial Distribution	fig
				MIN	TYP	V <sub>ce</sub>	E <sub>e</sub>		
	PS202	TO-18 can type, flat lens	800	0.6	3	5	10		15
	PS2022		880	0.1	2.5	5	1		
	PD202		800	2	6	5	0.01		
	PS302	φ 5 molded epoxy type, high-directivity lens	800	1	5	5	1		16
	PS3022		880	1.5	7	5	1		
	PD302		800	2	12	5	0.01		
	PS3062	φ 3 molded epoxy type, high-directivity lens	880	1.2	6	5	1		17
	PD306		800	0.5	2	5	0.01		
	PS3072	φ 3 molded epoxy type	880	2	7	5	1		18
	PD307		800	0.8	3	5	0.01		
	PS4032	φ 3 molded epoxy type, flat lens	880	1.5	5	5	10		19
	PD403		800	0.5	2	5	0.1		
Units			nm		mA	V	mw/cm <sup>2</sup>		

## ▼PACKAGE DIMENSIONS Unit : mm

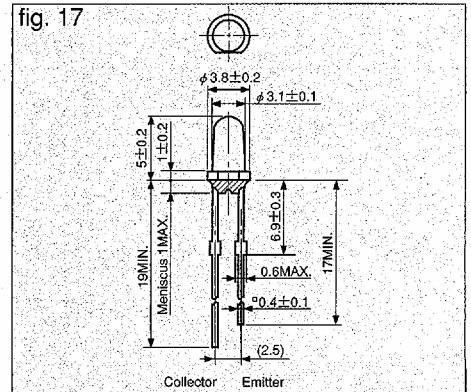
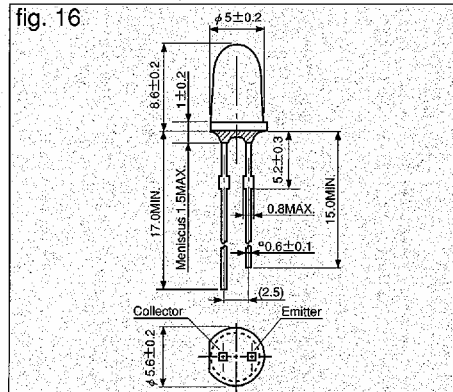
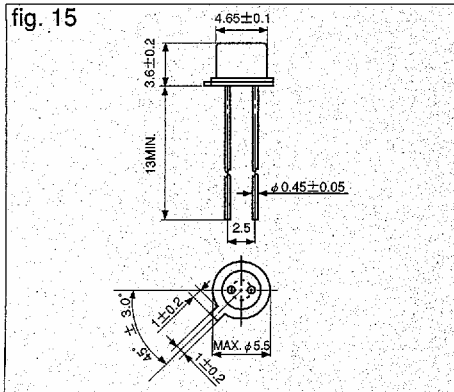

# ▼CHARACTERISTICS BY SHAPE

Ta=25°C

Shape	Type No.	Features	Peak Sensitive Wavelength		Photo Current I <sub>c</sub>			Spatial Distribution	fig.
			λ <sub>p</sub> TYP.	MIN.	TYP.	V <sub>CE</sub>	E <sub>e</sub>		
	PS502	φ 3.4 axial-lead type	800	3	15	5	10		20
	PS5022		880	0.4	2	5	1		
	PD502		800	1	4	5	0.01		
	PS504	φ 3.6 side-view type	800	2	10	5	10		21
	PS5042		880	0.4	1.4	5	1		
	PD504		800	0.5	2	5	0.1		
	PS505	Side-view type, high directivity	800	3	14	5	10		22
	PS5052		880	0.3	1.4	5	1		
	PS5132	φ 5 molded epoxy type with high precise flat lens	880	2.1	6.3	5	10		3
	PS1101W	Chip type	880	0.7	3.5	5	5		23
Units			nm		mA	V	mW/cm <sup>2</sup>		

# ▼PACKAGE DIMENSIONS Unit : mm

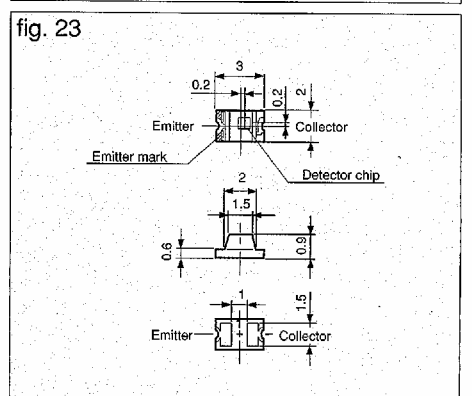
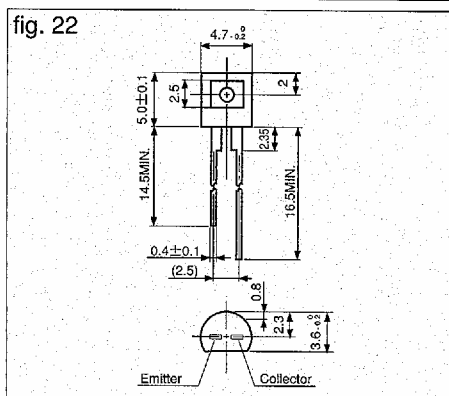
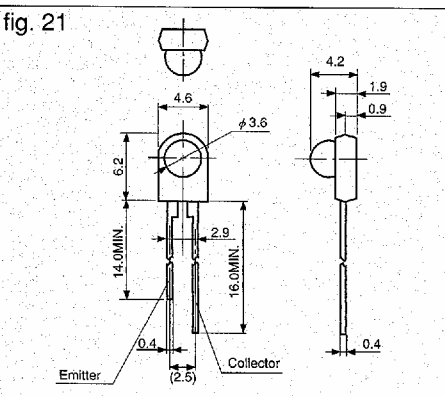
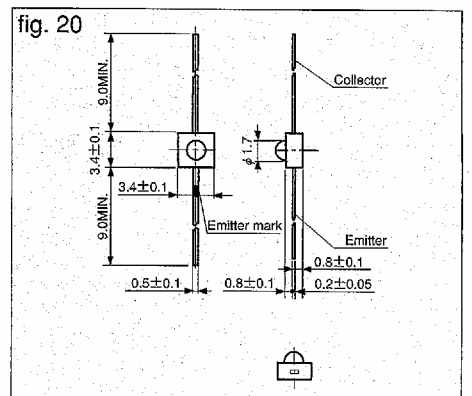
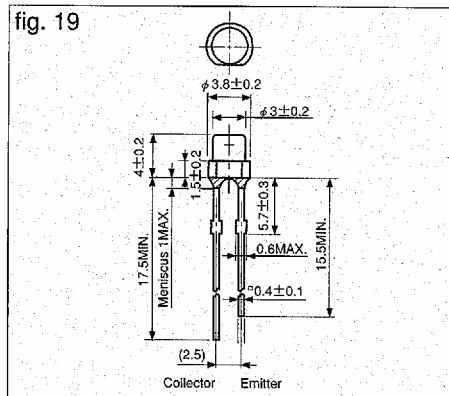
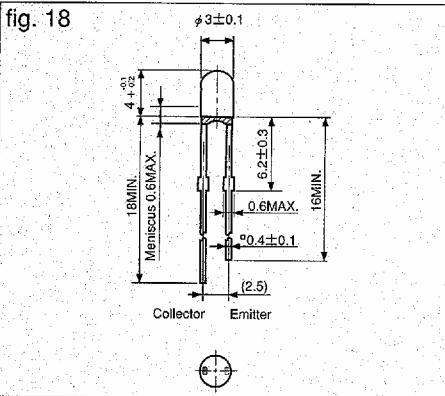

# PIN PHOTODIODE

## ▼CHARACTERISTICS

Ta=25°C

Type No.	Absolute Maximum Ratings				Electro-Optical Characteristics														fig.
	Power Dissipation Pd	Reverse Voltage Vr	Operating Temp Topr	Storage Temp Tstg	Photo Current I <sub>p</sub>			Response Time T <sub>r-11</sub>			Capacitance C <sub>t</sub>			Dark Current I <sub>d</sub>		Peak Sensitive Wavelength λ <sub>p</sub>			
					TYP	V <sub>r</sub>	E <sub>e</sub> ※	TYP	V <sub>r</sub>	R <sub>L</sub>	TYP	V <sub>r</sub>	f	MAX	V <sub>r</sub>	TYP	V <sub>r</sub>		
PP202	50	80	-30~+100	-30~+125	13	5	5	50	10	1,000	8	10	1	10	10	950	0	24	
PP403	75	30	-30~+85	-30~+100	1.5	5	0.5	20	10	1,000	7	10	1	10	10	950	0	25	
PP513F	30	30	-30~+85	-30~+100	2.9	5	5	1.4	30	50	20	10	1	10	10	950	0	3	
PP506	150	30	-30~+85	-30~+100	6.5	5	0.5	100	10	1,000	13	10	1	30	10	950	0	26	
PP506-1	150	30	-30~+85	-30~+100	5.5	5	0.5	100	10	1,000	13	10	1	30	10	950	0		
PP506-2	150	30	-30~+85	-30~+100	3.5	5	0.5	100	10	1,000	13	10	1	30	10	950	0		
PP601	100	30	-30~+85	-30~+100	6	5	0.5	100	10	1,000	25	10	1	30	10	950	0	27	
PP601-1	100	30	-30~+85	-30~+100	4.8	5	0.5	100	10	1,000	25	10	1	30	10	950	0		
PP601-2	100	30	-30~+85	-30~+100	3	5	0.5	100	10	1,000	25	10	1	30	10	950	0		
PP602	500	30	-20~+70	-20~+70	440	12	5	200	12	1,000	60	12	1	100	12	950	0	28	
PP701	500	30	-20~+70	-20~+70	1100	12	5	200	12	1,000	60	12	1	100	12	950	0	29	
PP801	300	12	-20~+70	-20~+70	190	12	5	150	12	1,000	35	12	1	20	12	950	0	30	
Units	mW	V	°C	°C	μA	V	mW/cm <sup>2</sup>	nsec	V	Ω	pF	V	MHz	nA	V	nm	V		

※A standard tungsten filament lamp with 2,856K is used for the color temperature.

## ▼SPECTRAL SENSITIVITY CHARACTERISTICS

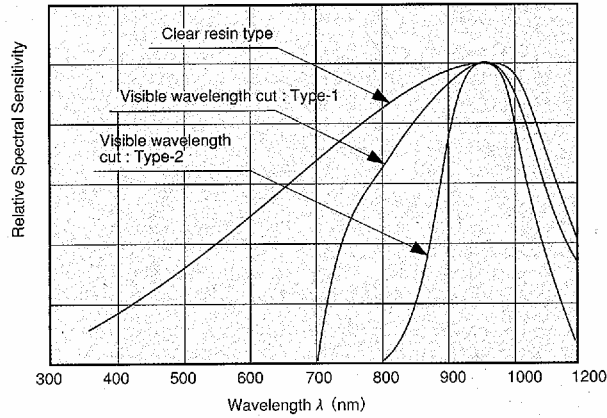

## ▼PACKAGE DIMENSIONS Unit : mm

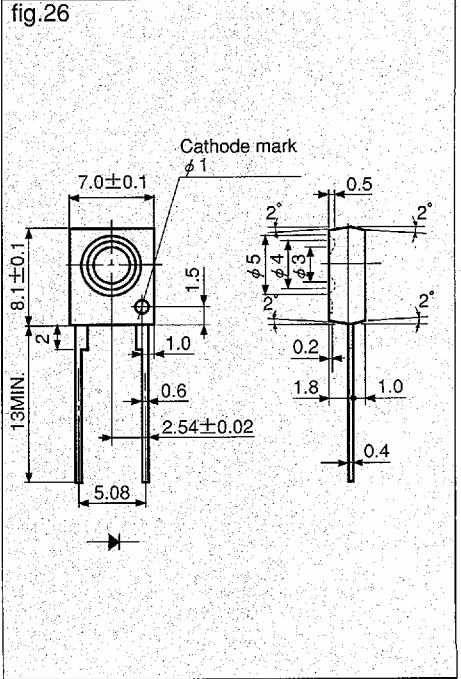
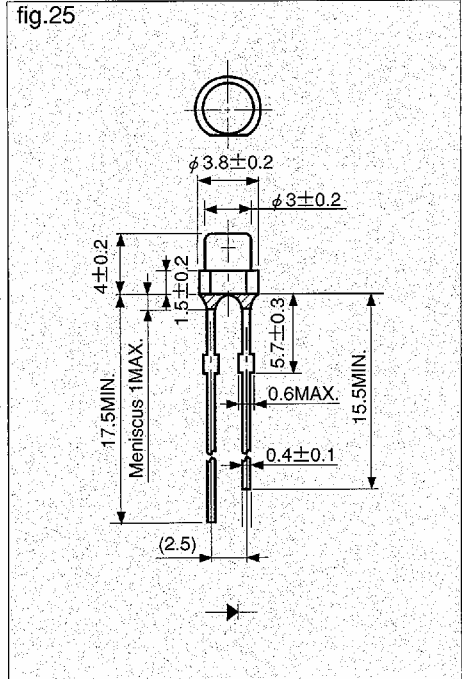
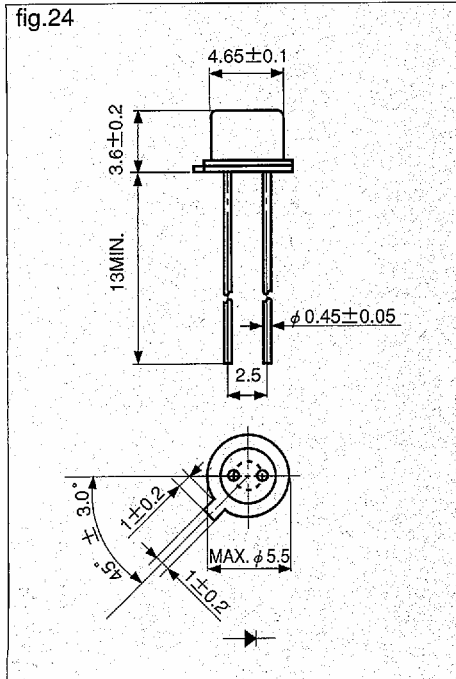



▼PACKAGE DIMENSIONS Unit : mm

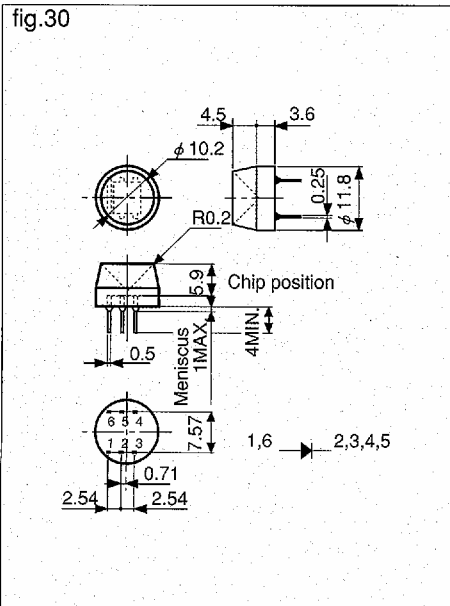
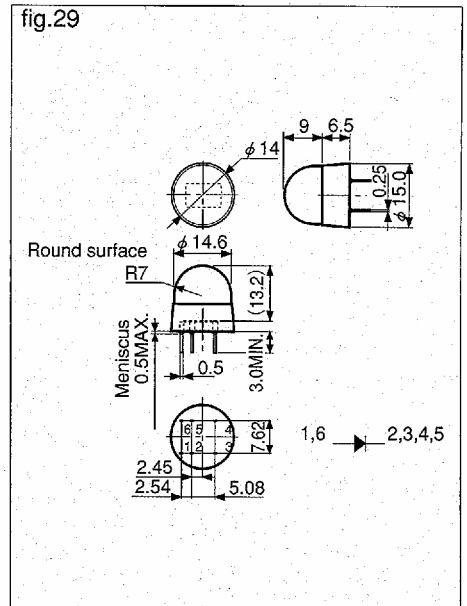
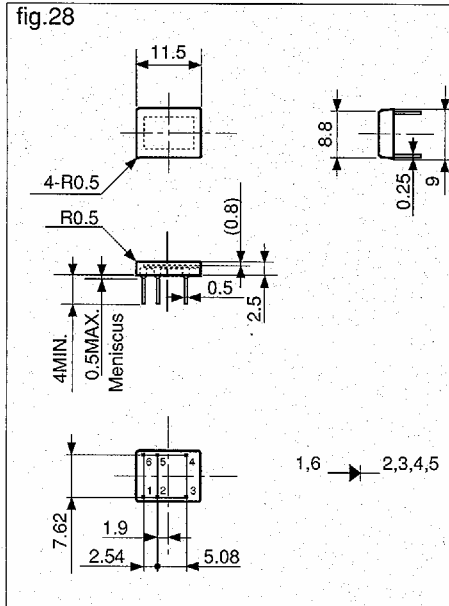
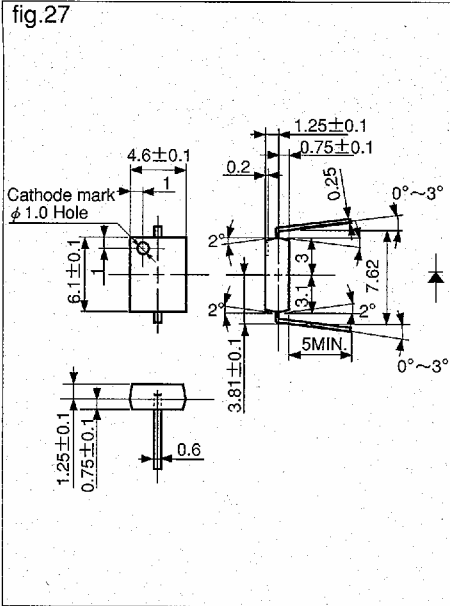

▼SPATIAL DISTRIBUTION

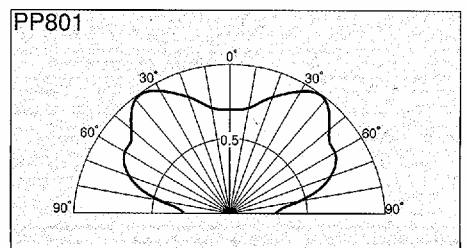
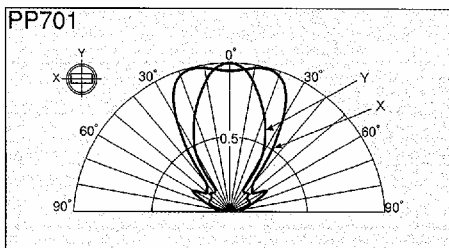
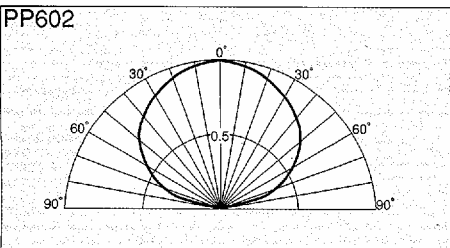
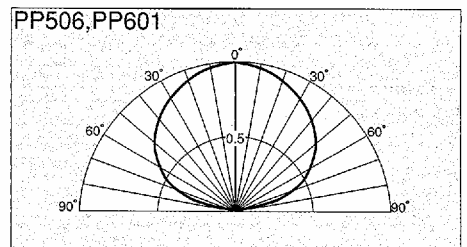
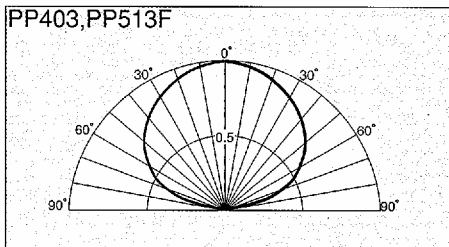
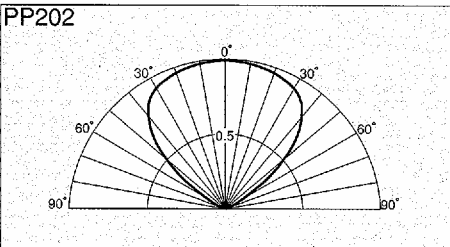

# LED USED FOR CAMERAS



LEDs used for cameras have a peak emission wavelength of 720 nm with high-intensity output. Because the LEDs are driven by a high pulse current, they can reach such high outputs. These LEDs are most suitable for auto-focus light sources or auxiliary light sources in the dark or in low ambient lighting conditions.

## ▼CHARACTERISTICS

Ta=25°C

Type No.	Material	Absolute Maximum Ratings						
		Power Dissipation Pd	Forward Current IF	×1 Derating IF	Peak Forward Current IFM	Reverse Voltage VR	Operating Temp. Topr	Storage Temp. Tstg
NR312	GaAlAs	200	100	1.33	150	3	-30~+85	-30~+100
NR403AF	GaAlAs	200	100	1.33	450	5	-30~+70	-30~+100
NR513	GaAlAs	200	100	1.33	450	5	-30~+70	-30~+100
Units		mW	mA	mA/C	mA	V	°C	°C

## ▼SPECTRAL SENSITIVITY CHARACTERISTICS

Ta=25°C

Type No.	Electro-Optical Characteristics													fig.
	Radiant Intensity IF		Photo output Po			Forward Voltage VF			Reverse Current IR		Wavelength			
	MIN	TYP	IF	TYP	IF	TYP	MIN	IF	MAX	VR	λp TYP	Δλ TYP	IF	
NR312	9.5	19.0	50	15	50	1.9	2.1	50	100	3	695	30	50	31
NR403AF	1.25	1.55	50	17	50	1.75	2.0	50	100	5	720	30	50	32
NR513	1.6	2.0	50	14	50	1.75	2.0	50	100	5	720	30	50	33
Units		mW/sr	mA	mW	mA	V	mA	μA	V	nm	nm	mA		

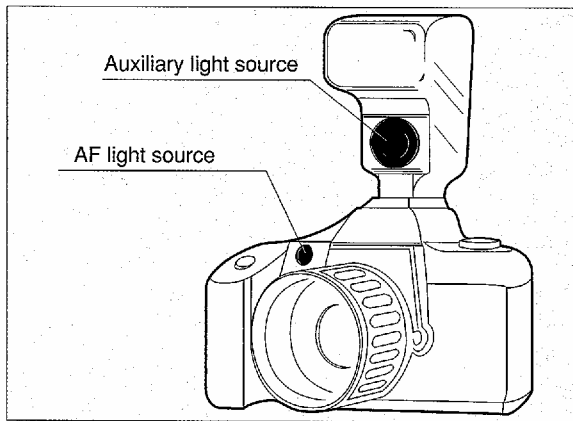

## ▼PACKAGE DIMENSIONS Unit : mm

