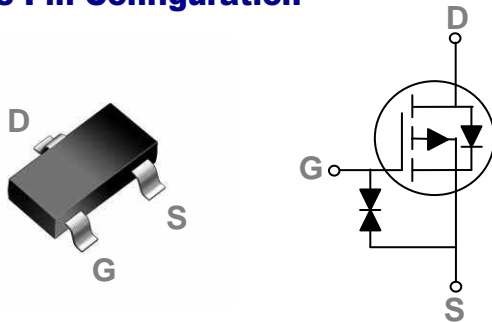


### General Description

These P-Channel enhancement mode power field effect transistors are using trench DMOS technology. This advanced technology has been especially tailored to minimize on-state resistance, provide superior switching performance, and withstand high energy pulse in the avalanche and commutation mode. These devices are well suited for high efficiency fast switching applications.

### SOT523 Pin Configuration



BVDSS	RDSON	ID
-20V	600mΩ	-400mA

### Features

- -20V,-400mA,  $R_{DS(ON)} = 600m\Omega @ V_{GS} = -4.5V$
- Improved  $dv/dt$  capability
- Fast switching
- Green Device Available
- Suit for -1.5V Gate Drive Applications

### Applications

- Notebook
- Load Switch
- Battery Protection
- Hand-held Instruments

### Absolute Maximum Ratings $T_C=25^\circ C$ unless otherwise noted

Symbol	Parameter	Rating	Units
$V_{DS}$	Drain-Source Voltage	-20	V
$V_{GS}$	Gate-Source Voltage	$\pm 8$	V
$I_D$	Drain Current – Continuous ( $T_C=25^\circ C$ )	-400	mA
	Drain Current – Continuous ( $T_C=100^\circ C$ )	-250	mA
$I_{DM}$	Drain Current – Pulsed <sup>1</sup>	-1.6	A
$P_D$	Power Dissipation ( $T_C=25^\circ C$ )	312	mW
	Power Dissipation – Derate above $25^\circ C$	2.5	mW/ $^\circ C$
$T_{STG}$	Storage Temperature Range	-55 to 150	$^\circ C$
$T_J$	Operating Junction Temperature Range	-55 to 150	$^\circ C$

### Thermal Characteristics

Symbol	Parameter	Typ.	Max.	Unit
$R_{\theta JA}$	Thermal Resistance Junction to ambient	---	400	$^\circ C/W$

**Electrical Characteristics ( $T_J=25^\circ\text{C}$ , unless otherwise noted)**
**Off Characteristics**

Symbol	Parameter	Conditions	Min.	Typ.	Max.	Unit
$BV_{DSS}$	Drain-Source Breakdown Voltage	$V_{GS}=0V, I_D=-250\mu A$	-20	---	---	V
$\Delta BV_{DSS}/\Delta T_J$	$BV_{DSS}$ Temperature Coefficient	Reference to $25^\circ\text{C}$ , $I_D=-1\text{mA}$	---	-0.01	---	$V/^\circ\text{C}$
$I_{DSS}$	Drain-Source Leakage Current	$V_{DS}=-20V, V_{GS}=0V, T_J=25^\circ\text{C}$	---	---	-1	$\mu A$
		$V_{DS}=-16V, V_{GS}=0V, T_J=125^\circ\text{C}$	---	---	-10	$\mu A$
$I_{GSS}$	Gate-Source Leakage Current	$V_{GS}=\pm 8V, V_{DS}=0V$	---	---	$\pm 20$	$\mu A$

**On Characteristics**

$R_{DS(ON)}$	Static Drain-Source On-Resistance	$V_{GS}=-4.5V, I_D=-0.3A$	---	440	600	m $\Omega$
		$V_{GS}=-2.5V, I_D=-0.2A$	---	610	850	
		$V_{GS}=-1.8V, I_D=-0.1A$	---	810	1200	
		$V_{GS}=-1.5V, I_D=-0.1A$	---	1020	1600	
		$V_{GS}=-1.2V, I_D=-0.1A$	---	1800	3000	
$V_{GS(th)}$	Gate Threshold Voltage	$V_{GS}=V_{DS}, I_D=-250\mu A$	-0.3	-0.6	-1.0	V
$\Delta V_{GS(th)}$	$V_{GS(th)}$ Temperature Coefficient		---	3	---	$\text{mV}/^\circ\text{C}$

**Dynamic and switching Characteristics**

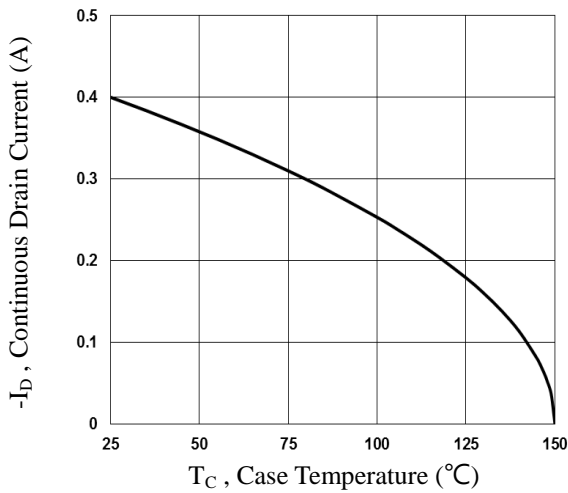
$Q_g$	Total Gate Charge <sup>2,3</sup>	$V_{DS}=-10V, V_{GS}=-4.5V, I_D=-0.2A$	---	1	2	nC
$Q_{gs}$	Gate-Source Charge <sup>2,3</sup>		---	0.28	0.5	
$Q_{gd}$	Gate-Drain Charge <sup>2,3</sup>		---	0.18	0.4	
$T_{d(on)}$	Turn-On Delay Time <sup>2,3</sup>	$V_{DD}=-10V, V_{GS}=-4.5V, R_G=10\Omega, I_D=-0.2A$	---	8	16	ns
$T_r$	Rise Time <sup>2,3</sup>		---	5.2	10	
$T_{d(off)}$	Turn-Off Delay Time <sup>2,3</sup>		---	30	60	
$T_f$	Fall Time <sup>2,3</sup>		---	18	36	
$C_{iss}$	Input Capacitance	$V_{DS}=-10V, V_{GS}=0V, F=1\text{MHz}$	---	40	78	pF
$C_{oss}$	Output Capacitance		---	15	30	
$C_{rss}$	Reverse Transfer Capacitance		---	6.5	13	

**Drain-Source Diode Characteristics and Maximum Ratings**

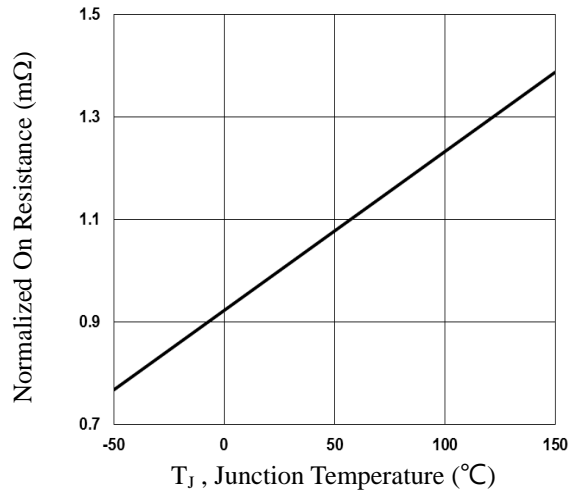
Symbol	Parameter	Conditions	Min.	Typ.	Max.	Unit
$I_S$	Continuous Source Current	$V_G=V_D=0V, \text{Force Current}$	---	---	-0.4	A
$I_{SM}$	Pulsed Source Current		---	---	-0.8	A
$V_{SD}$	Diode Forward Voltage	$V_{GS}=0V, I_S=-0.2A, T_J=25^\circ\text{C}$	---	---	-1	V

Note :

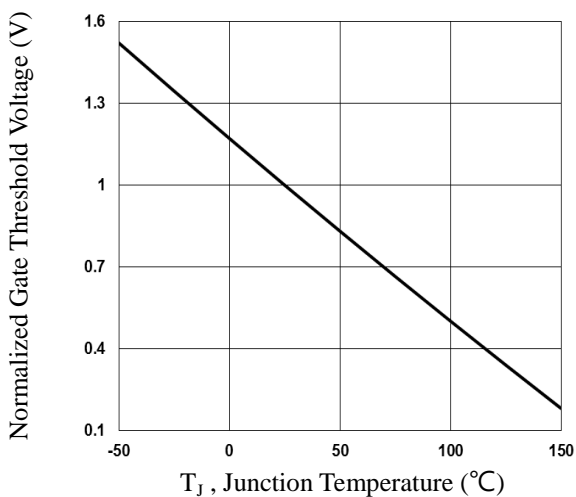
1. Repetitive Rating : Pulsed width limited by maximum junction temperature.
2. The data tested by pulsed , pulse width  $\leq 300\mu s$  , duty cycle  $\leq 2\%$ .
3. Essentially independent of operating temperature.



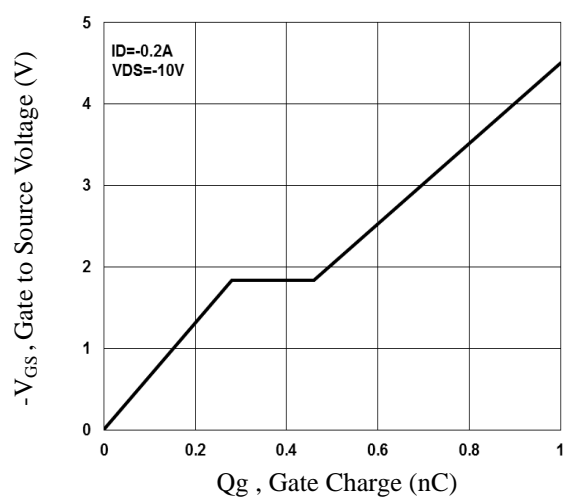
**Fig.1 Continuous Drain Current vs.  $T_c$**



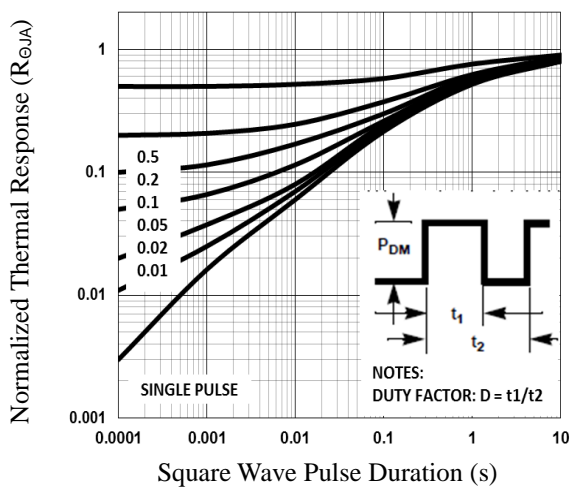
**Fig.2 Normalized  $R_{DS(on)}$  vs.  $T_j$**



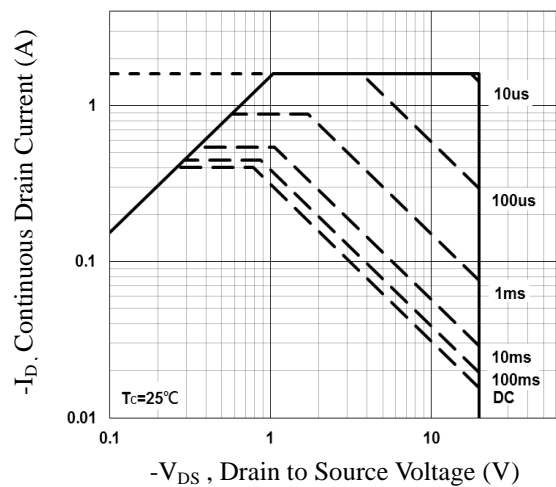
**Fig.3 Normalized  $V_{th}$  vs.  $T_j$**



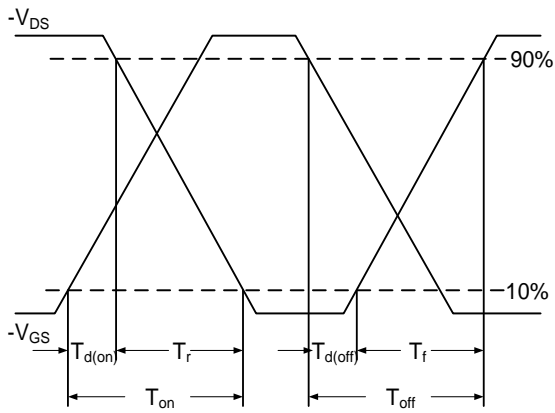
**Fig.4 Gate Charge Waveform**



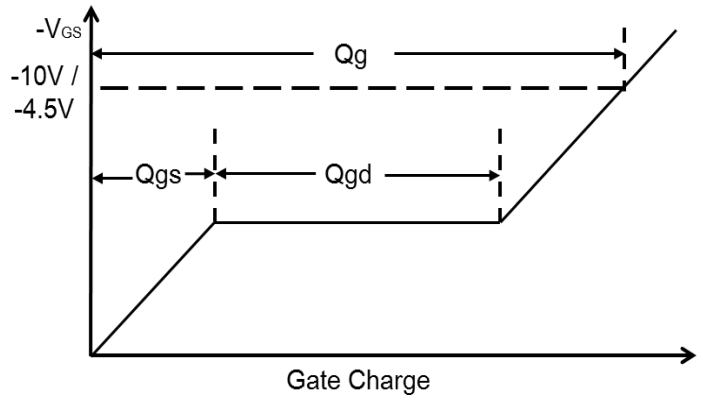
**Fig.5 Normalized Transient Response**



**Fig.6 Maximum Safe Operation Area**

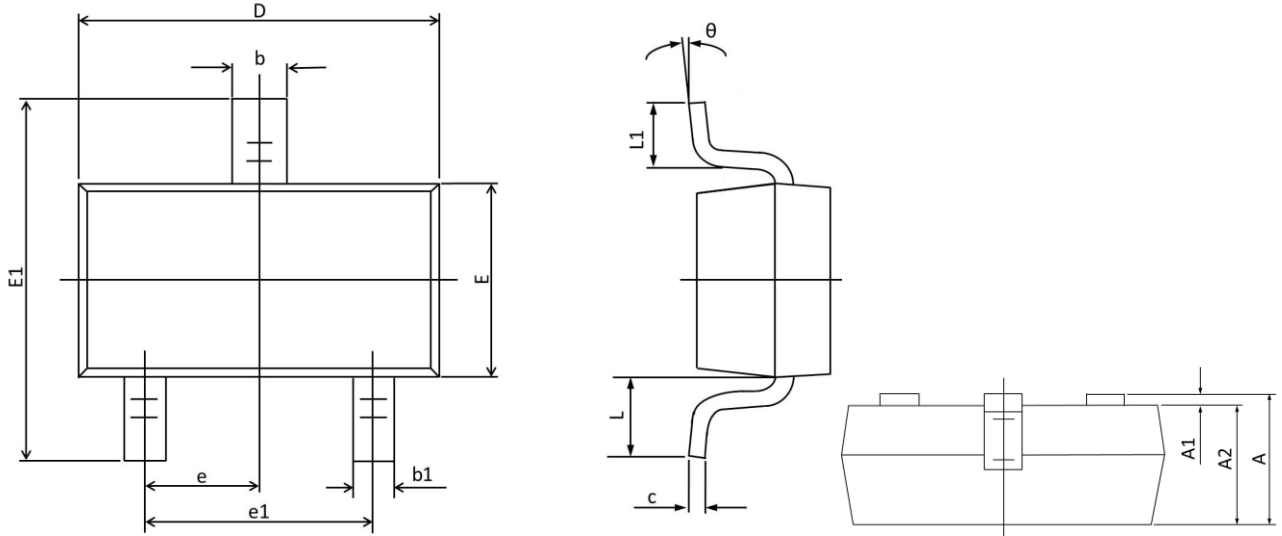


**Fig.7 Switching Time Waveform**



**Fig.8 Gate Charge Waveform**

## SOT523 PACKAGE INFORMATION



Symbol	Dimensions In Millimeters		Dimensions In Inches	
	MAX	MIN	MAX	MIN
A	0.900	0.700	0.035	0.028
A1	0.100	0.000	0.004	0.000
A2	0.800	0.700	0.031	0.028
b	0.350	0.250	0.014	0.010
b1	0.250	0.150	0.010	0.006
c	0.200	0.100	0.008	0.004
D	1.750	1.500	0.069	0.059
E	0.900	0.700	0.035	0.028
E1	1.750	1.400	0.069	0.055
e	0.5TYP.		0.02TYP.	
e1	1.100	0.900	0.043	0.035
L	0.460	0.300	0.018	0.012
L1	0.460	0.260	0.018	0.010
$\theta$	8°	0°	8°	0°