

### General Description

These N-Channel enhancement mode power field effect transistors are using advanced super junction technology. This advanced technology has been especially tailored to minimize on-state resistance, provide superior switching performance, and withstand high energy pulse in the avalanche and commutation mode. These devices are well suited for high efficiency switch mode power supply

BVDSS	RDSON	ID
650V	5.2Ω	3A

### Features

- Improved dv/dt capability
- Fast switching
- 100% EAS Guaranteed
- Green Device Available

### TO220F Pin Configuration

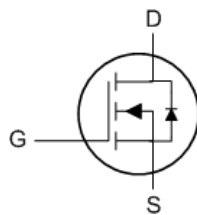

### Applications

- High efficient switched mode power supplies
- TV Power
- Adapter/charger
- LED Lighting

### Absolute Maximum Ratings $T_c=25^\circ\text{C}$ unless otherwise noted

Symbol	Parameter	Rating	Units
$V_{DS}$	Drain-Source Voltage	650	V
$V_{GS}$	Gate-Source Voltage	$\pm 30$	V
$I_D$	Drain Current – Continuous ( $T_C=25^\circ\text{C}$ )	3	A
	Drain Current – Continuous ( $T_C=100^\circ\text{C}$ )	1.9	A
$I_{DM}$	Drain Current – Pulsed <sup>1</sup>	12	A
EAS	Single Pulse Avalanche Energy <sup>2</sup>	65	mJ
IAS	Single Pulse Avalanche Current <sup>2</sup>	3.6	A
$P_D$	Power Dissipation ( $T_C=25^\circ\text{C}$ )	22	W
	Power Dissipation – Derate above $25^\circ\text{C}$	0.18	W/ $^\circ\text{C}$
$T_{STG}$	Storage Temperature Range	-55 to 150	$^\circ\text{C}$
$T_J$	Operating Junction Temperature Range	-55 to 150	$^\circ\text{C}$

### Thermal Characteristics

Symbol	Parameter	Typ.	Max.	Unit
$R_{\theta JA}$	Thermal Resistance Junction to ambient	---	62	$^\circ\text{C}/\text{W}$
$R_{\theta JC}$	Thermal Resistance Junction to Case	---	5.6	$^\circ\text{C}/\text{W}$

**Electrical Characteristics ( $T_J=25^\circ\text{C}$ , unless otherwise noted)**
**Off Characteristics**

Symbol	Parameter	Conditions	Min.	Typ.	Max.	Unit
$BV_{DSS}$	Drain-Source Breakdown Voltage	$V_{GS}=0V, I_D=250\mu A$	650	---	---	V
$\Delta BV_{DSS}/\Delta T_J$	$BV_{DSS}$ Temperature Coefficient	Reference to $25^\circ\text{C}$ , $I_D=1\text{mA}$	---	0.6	---	$V/^\circ\text{C}$
$I_{DSS}$	Drain-Source Leakage Current	$V_{DS}=650V, V_{GS}=0V, T_J=25^\circ\text{C}$	---	---	1	$\mu A$
		$V_{DS}=520V, V_{GS}=0V, T_J=125^\circ\text{C}$	---	---	10	$\mu A$
$I_{GSS}$	Gate-Source Leakage Current	$V_{GS}=\pm 30V, V_{DS}=0V$	---	---	$\pm 100$	nA

**On Characteristics**

$R_{DS(ON)}$	Static Drain-Source On-Resistance	$V_{GS}=10V, I_D=1A$	---	4	5.2	$\Omega$
$V_{GS(th)}$	Gate Threshold Voltage	$V_{GS}=V_{DS}, I_D=250\mu A$	3	---	5	V
$\Delta V_{GS(th)}$	$V_{GS(th)}$ Temperature Coefficient		---	-7	---	$\text{mV}/^\circ\text{C}$
$g_{fs}$	Forward Transconductance	$V_{DS}=10V, I_S=1A$	---	2.8	---	S

**Dynamic and switching Characteristics**

$Q_g$	Total Gate Charge <sup>3,4</sup>	$V_{DS}=520V, V_{GS}=10V, I_D=2A$	---	10.2	---	nC
$Q_{gs}$	Gate-Source Charge <sup>3,4</sup>		---	2.1	---	
$Q_{gd}$	Gate-Drain Charge <sup>3,4</sup>		---	5.5	---	
$T_{d(on)}$	Turn-On Delay Time <sup>3,4</sup>	$V_{DD}=300V, V_{GS}=10V, R_G=25\Omega$ $I_D=2A$	---	17.2	35	ns
$T_r$	Rise Time <sup>3,4</sup>		---	7.2	14	
$T_{d(off)}$	Turn-Off Delay Time <sup>3,4</sup>		---	23.5	47	
$T_f$	Fall Time <sup>3,4</sup>		---	17.4	35	
$C_{iss}$	Input Capacitance	$V_{DS}=25V, V_{GS}=0V, F=1\text{MHz}$	---	430	600	pF
$C_{oss}$	Output Capacitance		---	32	50	
$C_{rss}$	Reverse Transfer Capacitance		---	3.7	7	
$R_g$	Gate resistance	$V_{GS}=0V, V_{DS}=0V, F=1\text{MHz}$	---	2.4	---	$\Omega$

**Drain-Source Diode Characteristics and Maximum Ratings**

Symbol	Parameter	Conditions	Min.	Typ.	Max.	Unit
$I_S$	Continuous Source Current	$V_G=V_D=0V$ , Force Current	---	---	3	A
$I_{SM}$	Pulsed Source Current		---	---	12	A
$V_{SD}$	Diode Forward Voltage	$V_{GS}=0V, I_S=1A, T_J=25^\circ\text{C}$	---	0.5	1	V
$t_{rr}$	Reverse Recovery Time <sup>3</sup>	$V_{GS}=0V, I_S=1A, dI/dt=100A/\mu s$	---	---	---	ns
$Q_{rr}$	Reverse Recovery Charge <sup>3</sup>	$T_J=25^\circ\text{C}$	---	---	---	$\mu C$

**Note :**

1. Repetitive Rating : Pulsed width limited by maximum junction temperature.
2.  $V_{DD}=50V, V_{GS}=10V, L=10\text{mH}, I_{AS}=3.6A, R_G=25\Omega$ , Starting  $T_J=25^\circ\text{C}$ .
3. The data tested by pulsed, pulse width  $\leq 300\mu s$ , duty cycle  $\leq 2\%$ .
4. Essentially independent of operating temperature.

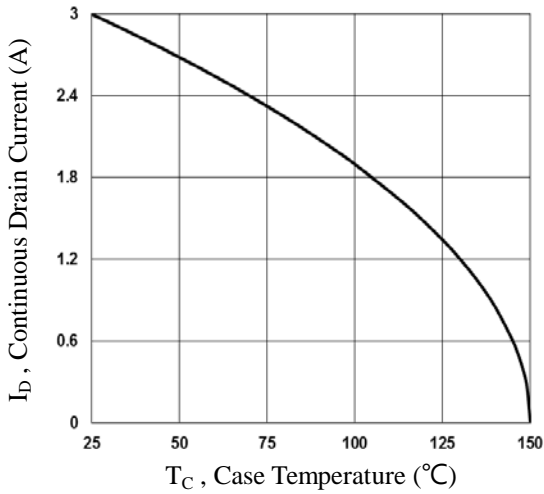

Fig.1 Continuous Drain Current vs.  $T_c$

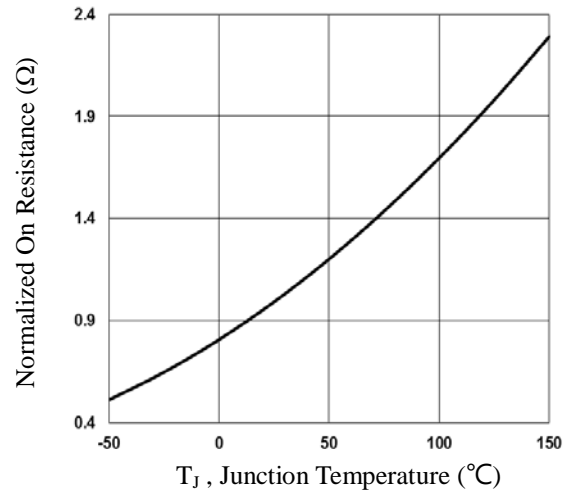

Fig.2 Normalized  $R_{DSon}$  vs.  $T_j$

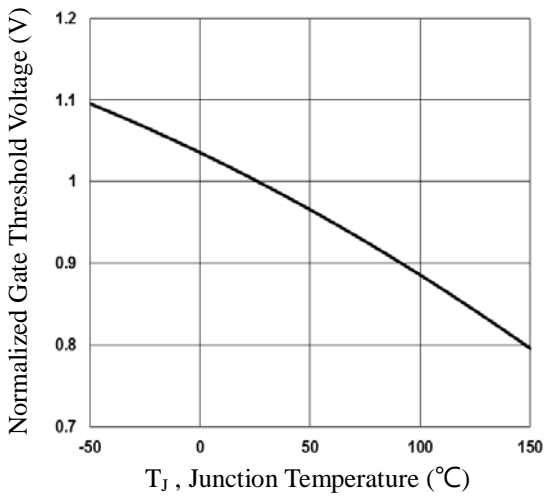

Fig.3 Normalized  $V_{th}$  vs.  $T_j$

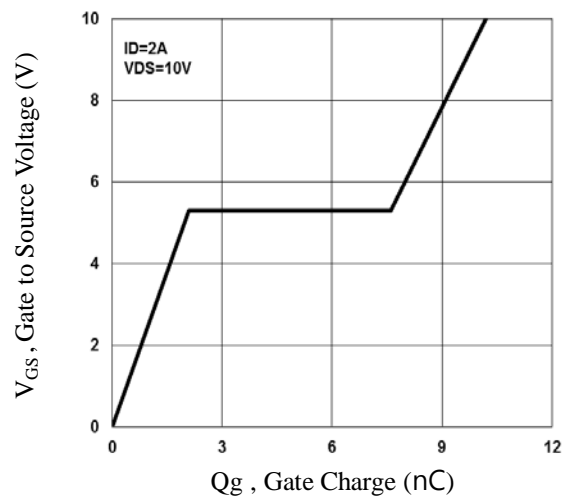

Fig.4 Gate Charge Waveform

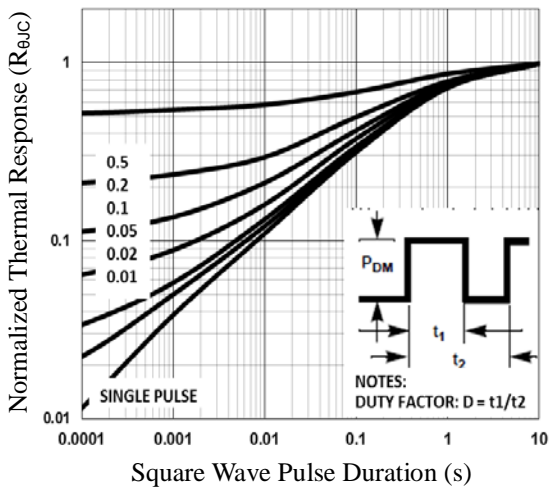

Fig.5 Normalized Transient Impedance

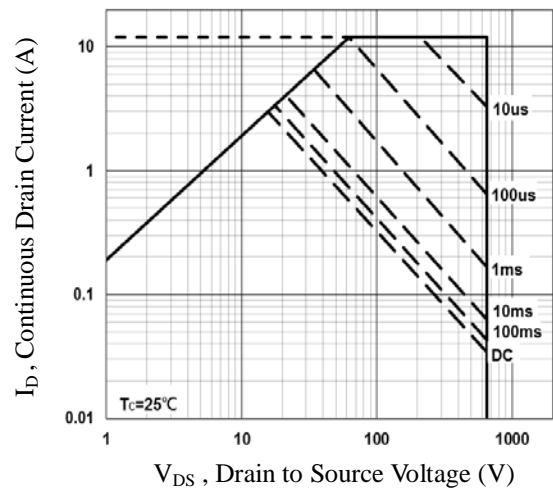

Fig.6 Maximum Safe Operation Area

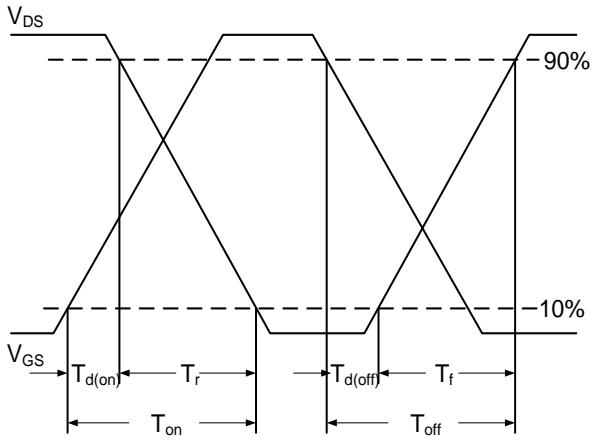

Fig.7 Switching Time Waveform

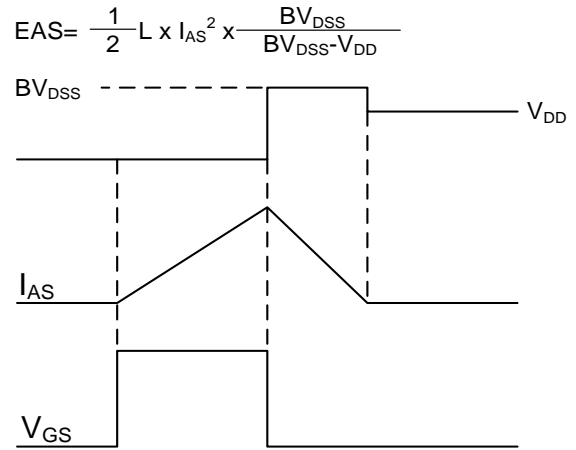
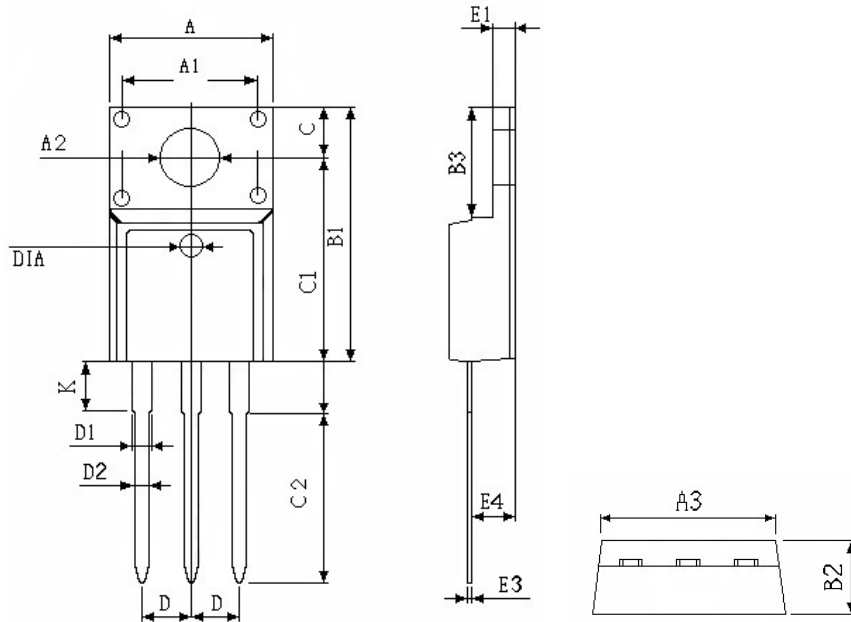

Fig.8 EAS Waveform

## TO220F PACKAGE INFORMATION



Symbol	Dimensions In Millimeters		Dimensions In Inches	
	Min	Max	Min	Max
A	9.860	10.460	0.389	0.411
A1	6.900	7.100	0.272	0.279
A2	3.100	3.500	0.123	0.137
B1	9.500	9.900	0.375	0.389
B2	4.500	4.900	0.178	0.192
B3	6.480	6.880	0.256	0.271
C	3.100	3.500	0.123	0.137
C1	12.270	12.870	0.484	0.506
C2	12.580	13.380	0.496	0.526
D	2.490	2.590	0.099	0.101
D1	1.070	1.470	0.043	0.057
D2	0.700	0.900	0.028	0.035
K	2.900	3.300	0.115	0.129
E1	2.340	2.740	0.093	0.107
E3	0.400	0.600	0.016	0.023
E4	2.560	2.960	0.101	0.116
DIA	1.45	1.55	0.058	0.061