

PE

General Purpose

www.DataSheet4U.com

RFI Power Line Filters

Electrical schematics

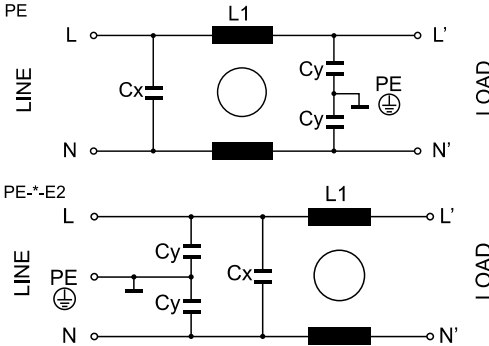

General Specifications

Maximum operating voltage: 250Vac.
 Operating frequency: DC - 60Hz.
 Hipot test voltage: L/N->PE: 1800Vac 2s.
 L->N: 1700 Vdc 2s.
 Application class: HPF Acc. TO DIN 40040
 (-25°C/+85°C/95% RH, 30d).
 Flammability class: UL 94 V2.

General Purpose

Plastic case filter for PCB mounting.
 Low cost and space saving filter.
 Good attenuation for wide frequency range.
 Low leakage current < 0,25 mA.
 For digital logic circuits.

Product List

TYPE	I	L1	CX	CY	HOUSING	L.CURRENT	CONNECTION	WEIGHT ±g
PE-05V	0,5 Amp	20 mH	10 nF	2,2 nF	201	0,21 mA	PIN 0,8mm	27
PE-05V-E2					202		PIN 0,8mm	
PE-1V	1 Amp	10 mH	10 nF	2,2 nF	201	0,21 mA	PIN 0,8mm	28
PE-1V-E2					202		PIN 0,8mm	
PE-3V	3 Amp	1,3 mH	10 nF	2,2 nF	201	0,21 mA	PIN 0,8mm	28
PE-3V-E2					202		PIN 0,8mm	
PE-6V	6 Amp	0,8 mH	10 nF	2,2 nF	201	0,21 mA	PIN 0,8mm	27
PE-6V-E2					202		PIN 0,8mm	

Insertion Loss

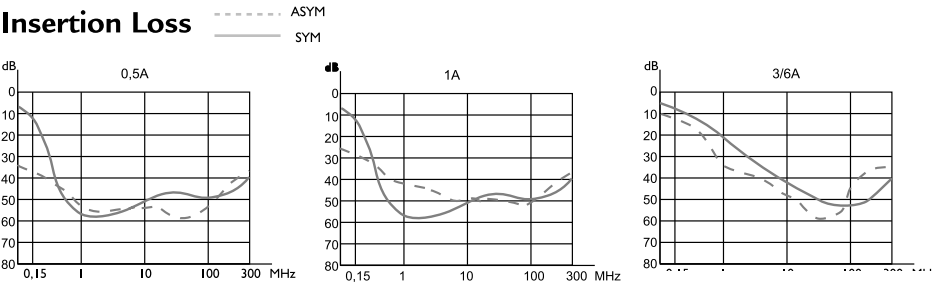

www.DataSheet4U.com