

SPECIFICATIONS

CUSTOMER	.	CKR001
SAMPLE CODE	:	SE12864LRU-022-H-Q
MASS PRODUCTION CODE	:	PE12864LRU-022-H-Q
SAMPLE VERSION	:	01
SPECIFICATIONS EDITION	:	001
DRAWING NO. (Ver.)	:	JLMD- PE12864LRU-022-H-Q_002
PACKAGING NO. (Ver.)	:	JPKG- PE12864LRU-022-H-Q_002

Customer Approved

Date:



Approved	Checked	Designer
閔偉	劉進	譚超敏

- Preliminary specification for design input
- Specification for sample approval

POWER TIP TECH. CORP.

Headquarters: No.8, 6 th Road, Taichung Industrial Park, Taichung, Taiwan 台中市 407 工業區六路 8 號	TEL: 886-4-2355-8168 FAX: 886-4-2355-8166	E-mail: sales@powertip.com.tw Http://www.powertip.com.tw
--	--	--

Contents

1. SPECIFICATIONS

- 1.1 Features
- 1.2 Mechanical Specifications
- 1.3 Absolute Maximum Ratings
- 1.4 DC Electrical Characteristics
- 1.5 Optical Characteristics
- 1.6 Backlight Characteristics

2. MODULE STRUCTURE

- 2.1 Counter Drawing
- 2.2 Interface Pin Description
- 2.3 Timing Characteristics
- 2.4 Display Command

3. QUALITY ASSURANCE SYSTEM

- 3.1 Quality Assurance Flow Chart
- 3.2 Inspection Specification

4. RELIABILITY TEST

- 4.1 Reliability Test Condition

5. PRECAUTION RELATING PRODUCT HANDLING

- 5.1 Safety
- 5.2 Handling
- 5.3 Storage
- 5.4 Terms of Warranty

- Appendix :
- 1. LCM Drawing
 - 2. Packaging

1. SPECIFICATIONS

1.1 Features

Item	Standard Value
Display Type	128 * 64 Dots
LCD Type	STN Y/G, Positive, Transflective
Driver Condition	LCD Module : 1/65 Duty, 1/9 Bias
Viewing Direction	6 O'clock
Backlight Type	LED B/L
Weight	27.3g
Interface	8 bits parallel data input
Controller / Driver IC	ST7565S-G
ROHS	THIS PRODUCT CONFORMS THE ROHS OF PTC Detail information please refer web site : http://www.powertip.com.tw/news.php?area_id_view=1085560481/

1.2 Mechanical Specifications

Item	Standard Value	Unit
Outline Dimension	93.7 (W) * 53.0 (L) * 4.7(H)MAX	mm
Viewing Area	70.7 (L) * 38.8 (W)	mm
Active Area	66.52 (L) * 33.24 (W)	mm
Dot Size	0.48 (L) * 0.48 (W)	mm
Dot Pitch	0.52 (L) * 0.52 (W)	mm

Note : For detailed information please refer to LCM drawing

1.3 Absolute Maximum Ratings

Item	Symbol	Condition	Min.	Max.	Unit
Power Supply Voltage	V _{DD}	-	-0.3	+5.0	V
LCD Driver Supply Voltage	V _{DD-V5}	-	-0.3	+18.0	V
Input Voltage	V _{IN}	-	-0.3	V _{DD} +0.3	
Operating Temperature	T _{OP}	-	-20	+70	°C
Storage Temperature	T _{ST}	-	-30	+80	°C
Storage Humidity	H _D	Ta < 40 °C	20	90	%RH

1.4 DC Electrical Characteristics

VDD = 3.3V, VSS = 0V, Ta = 25°C

Item	Symbol	Condition	Min.	Typ.	Max.	Unit
Logic Supply Voltage	V _{DD}	-	3.0	3.3	3.6	V
“H” Input Voltage	V _{IH}	-	0.8V _{DD}	-	V _{DD}	V
“L” Input Voltage	V _{IL}	-	V _{SS}	-	0.2V _{DD}	V
“H” Output Voltage	V _{OH}	-	0.8V _{DD}	-	V _{DD}	V
“L” Output Voltage	V _{OL}	-	V _{SS}	-	0.2V _{DD}	V
Supply Current	IDD	VDD= 3.3V; V _{OP} = 10.0 V; Pattern= Horizontal line*1	-	0.2	1.0	mA
LCM Driver Voltage	V _{op}	-20°C	10.2	10.4	10.6	V
		+25°C	9.8	10.0	10.2	
		+70°C	9.0	9.2	9.4	

Note : *1. The Maximum current display.

*2. The V_{OP} test point is V_{DD}-V₅.

1.5 Optical Characteristics

LCD Panel: 1/65 Duty, 1/9 Bias, VLCD = 10.0V, Ta = 25°C

Item		Symbol	Conditions	Min.	Typ.	Max.	Unit	Reference
Response Time	Rise	tr	-	-	150	-	ms	Note 2
	Fall	tf		-	300	-		
Viewing angle range	Rear	$\Theta+$	$C \geq 2.0$	40	-	-	-	Notes 1
	Front	$\Theta-$		40	-	-		
	Left	ΘL		45	-	-		
	Right	ΘR		45	-	-		
Contrast Ratio		CR	-	5	7	-	-	Note 3
Average Brightness (With LCD&B/L) *2		IV	If=100mA	3	7	-	cd/m ²	Note 4
Wave Length (With LCD&B/L) *2		λ_D		569	572	575	nm	
Uniformity *1		ΔB	-	70	-	-	%	-

Note 4 :

1 : $\Delta B = B(\text{min}) / B(\text{max}) * 100\%$

2 : Measurement Condition for Optical Characteristics:

a : Environment: $25^\circ\text{C} \pm 5^\circ\text{C}$ / $60 \pm 20\%$ R.H , no wind , dark room below 10 Lux at typical lamp current and typical operating frequency.

b : Measurement Distance: 500 ± 50 mm , ($\theta = 0^\circ$)

c : Equipment: TOPCON BM-7 fast , (field 0.2°) , after 10 minutes operation.

d : The uncertainty of the C.I.E coordinate measurement ± 0.01 , Average Brightness $\pm 4\%$

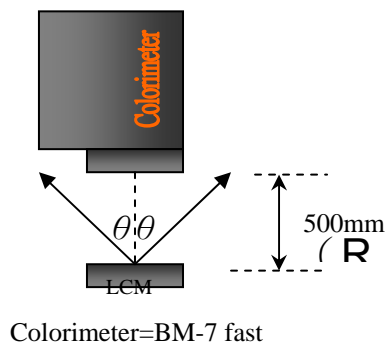
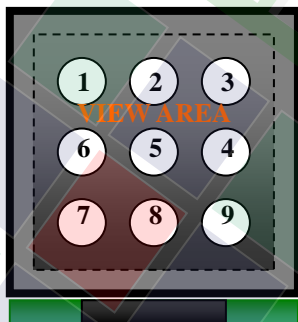

3 : This value will be changed while mass production.

Note 1.

Optical characteristics-2

Viewing angle

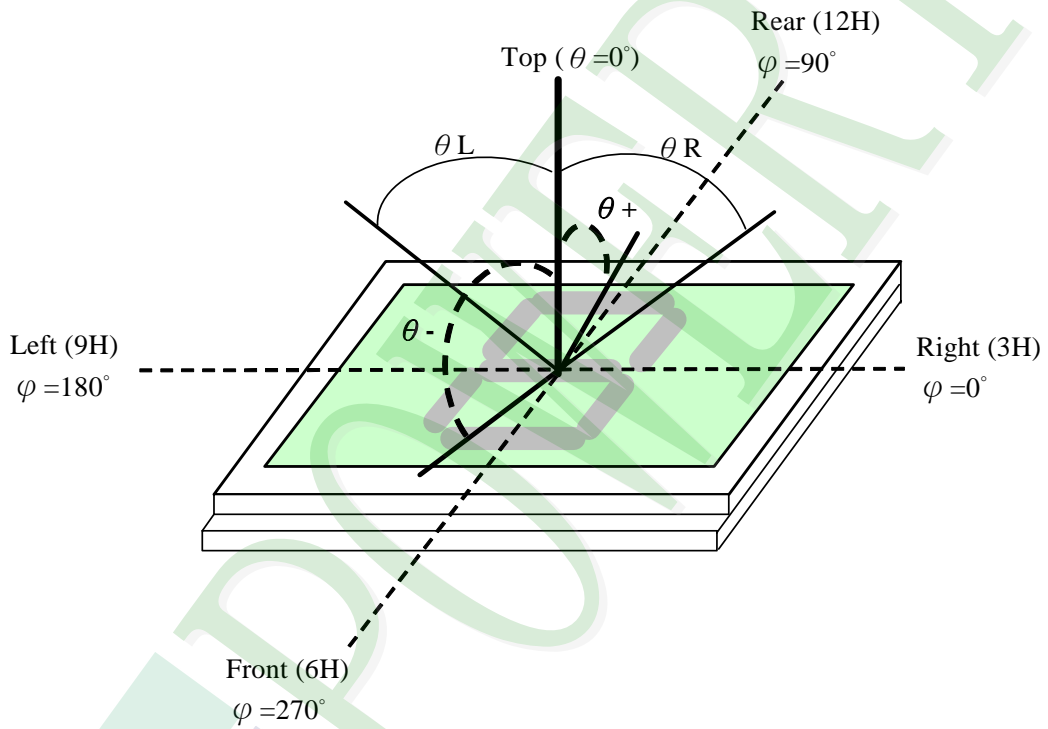

Viewing angle

Note 2.

Optical characteristics-3

Fig.2 Definition of response time

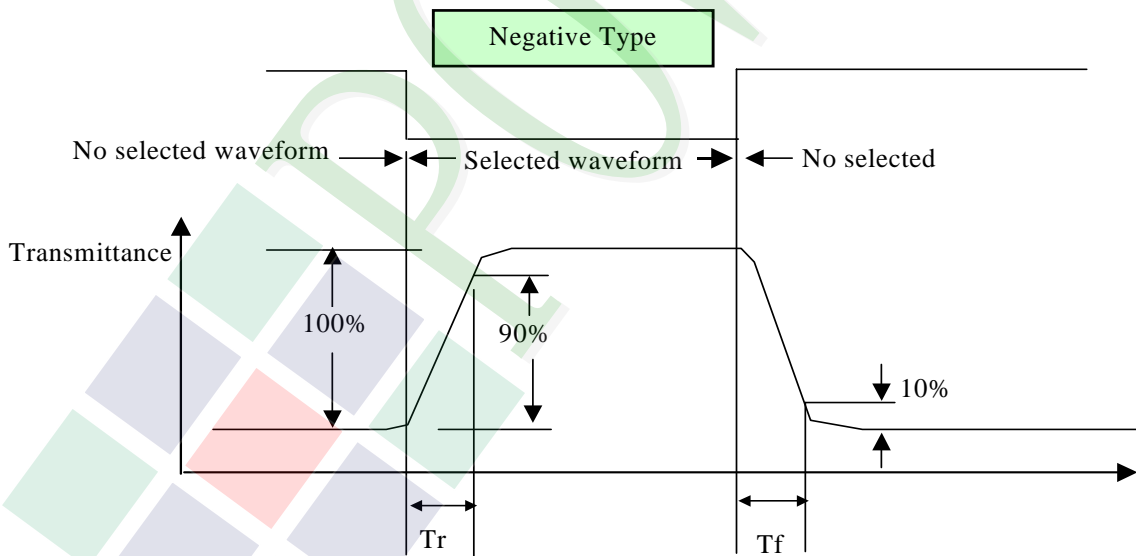
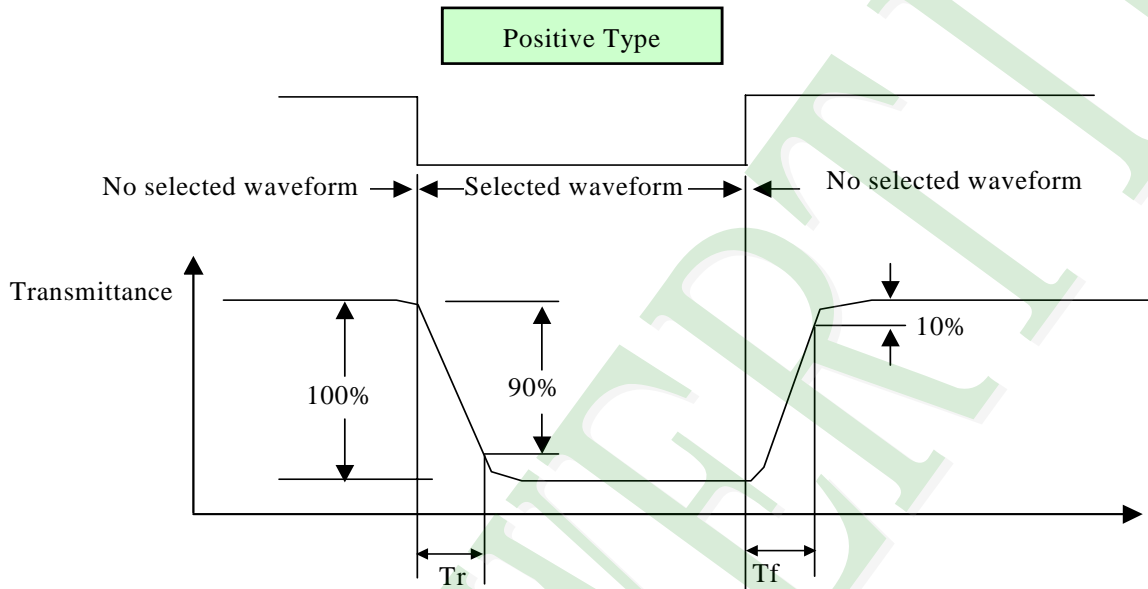

Electrical characteristics-2

※2 Drive waveform

V_{op} : Drive voltage

$1/B$: Bias

N : Duty

fF : Frame frequency

fD : Drive frequency

(1) Selected waveform

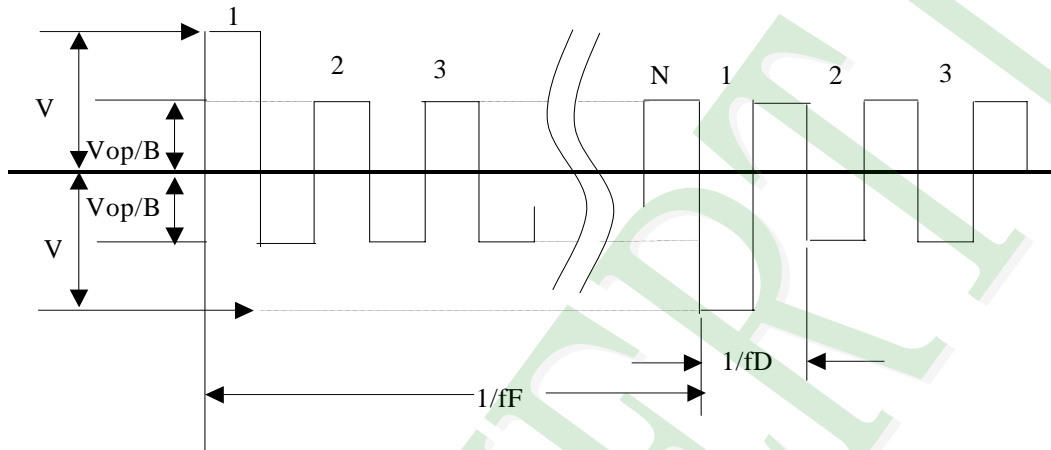

(2) Non- Selected wave form

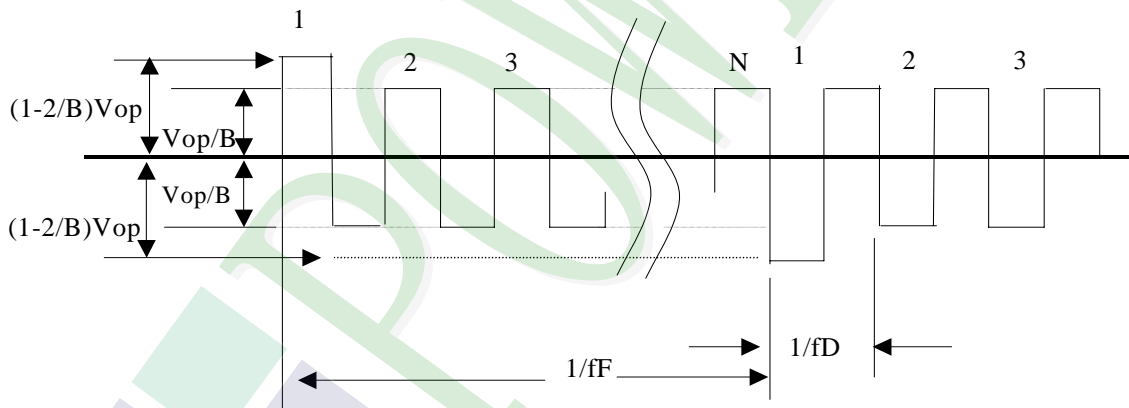

Note:

Frame frequency is defined as follows: Common side supply voltage peak - to - peak / 2 = 1 period

Note 3. : Definition of Vth

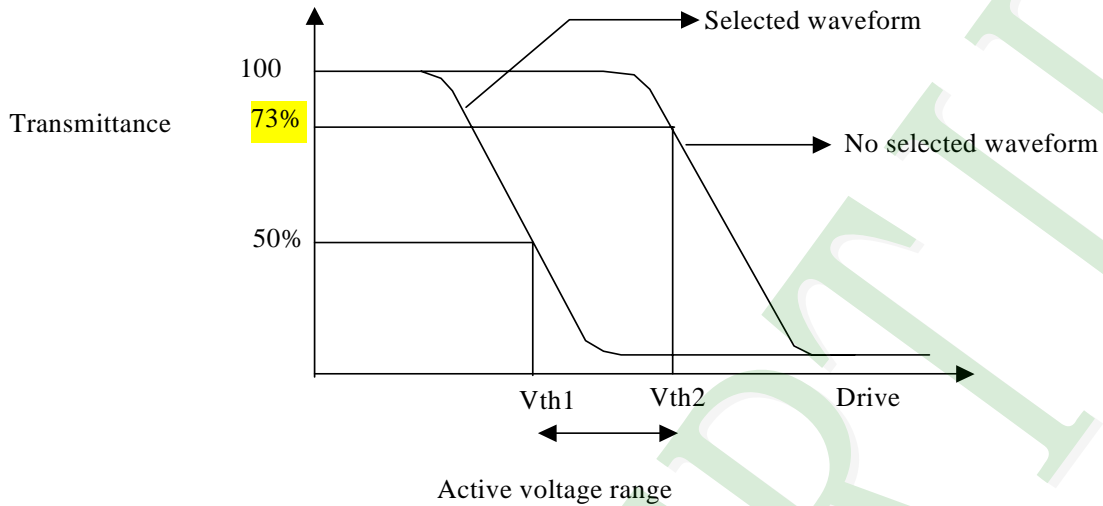

	Vth1	Vth2
View direction	10°	40°
Drive waveform	(Selected waveform)	(No selected waveform)
Transmittance	50%	73%

※ 1 Contrast ratio
= (Brightness in OFF state) / (Brightness in ON state)

Outline of Electro-Optical Characteristics Measuring System

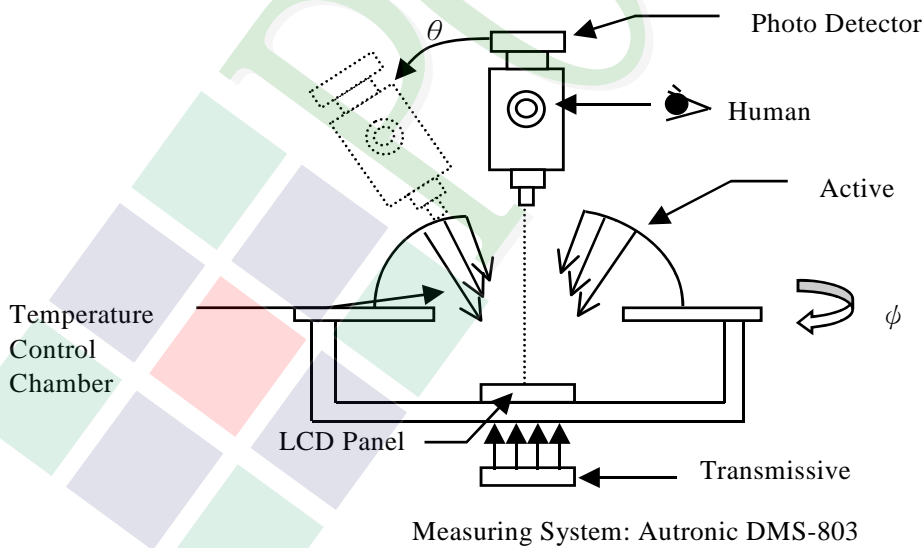

1.6 Backlight Characteristics

Maximum Ratings

Item	Symbol	Conditions	Min.	Max.	Unit
Peak forward current	IF	Ta =25°C	-	160	mA
Reverse Voltage	VR		-	5	V
Power dissipation	Pd		-	400	mW

Electrical / Optical Characteristics

Ta =25°C

Item	Symbol	Conditions	Min.	Typ.	Max.	Unit
Forward Voltage	VF	IF= 100 mA	1.9	2.2	2.4	V
Peak Wave Length (Without LCD)*1	λ_P		569	572	575	nm
Spectral Line Half Width (Without LCD) *1	$\Delta\lambda$		-	30	-	nm
Average Brightness (Without LCD) *1	IV		52	70	-	cd/m ²
Uniformity *2	ΔB		65	-	-	
Color	Yellow -Green					

*1 This value will be changed while mass production.

*2 : $\Delta B = B(\min) / B(\max) * 100\%$

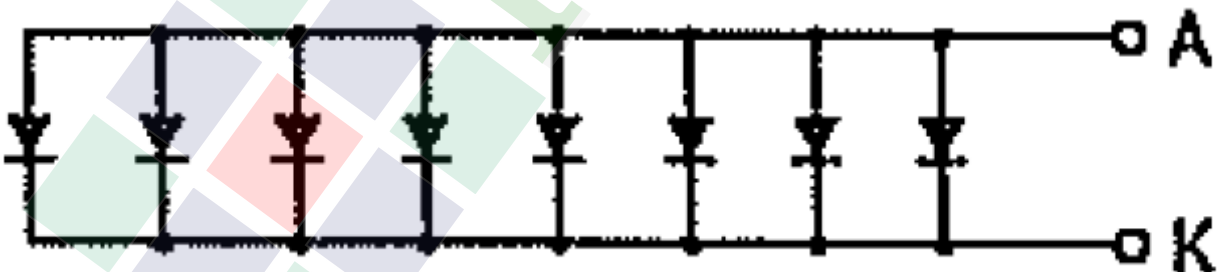

2. MODULE STRUCTURE

2.1 Counter Drawing

2.1.1 LCM Mechanical Diagram

* See Appendix

2.1.2 Block Diagram

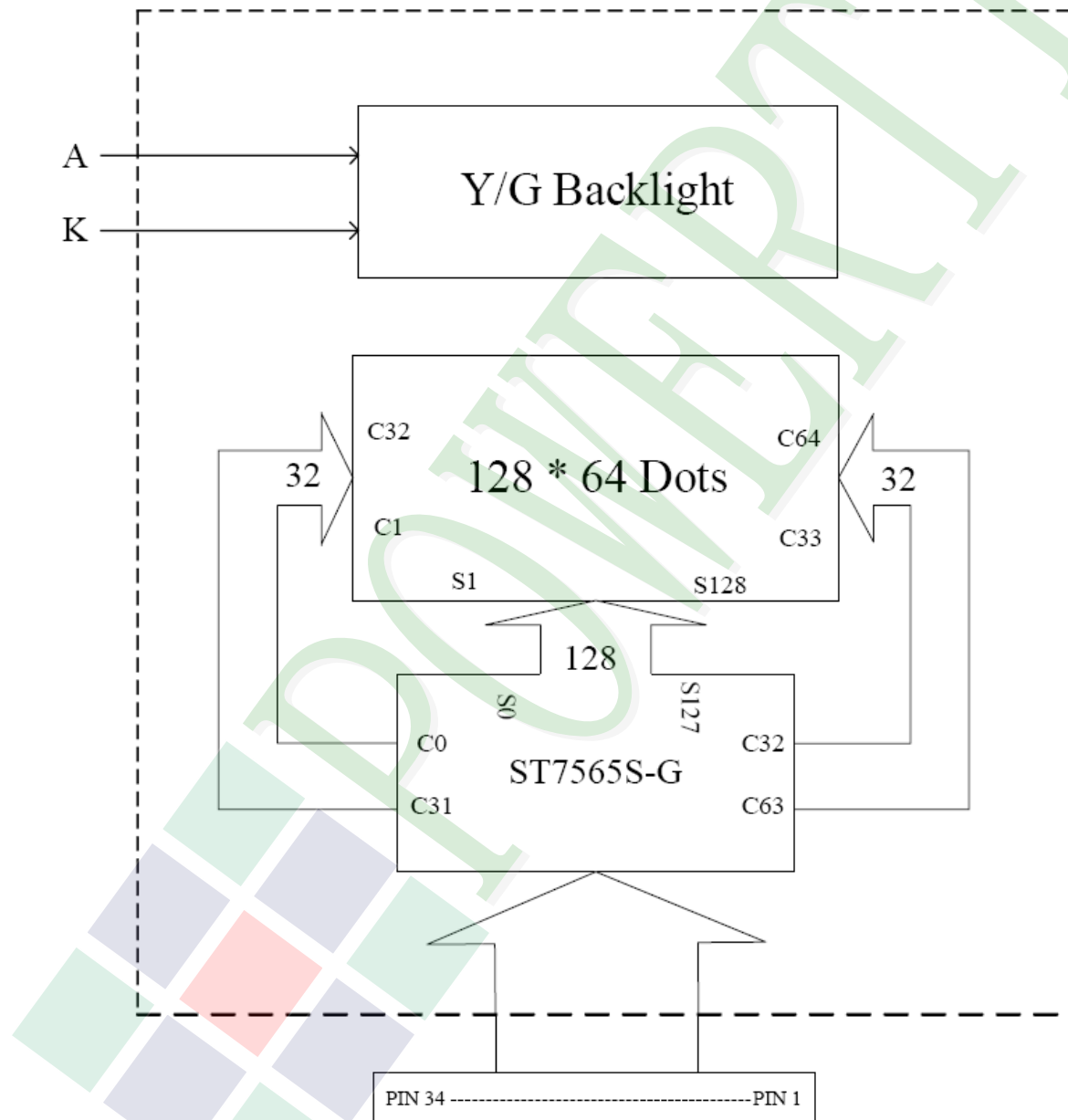

Please refer interface pin description for detail

2.2 Interface Pin Description

Pin No.	Symbol	Function
1	/CS1	This is the chip select signal. When /CS1 = "L", then the chip select becomes active, and data/command I/O is enabled.
2	/RES	When /RES is set to "L," the settings are initialized.
3	A0	This is connect to the least significant bit of the normal MPU address bus, and it determines whether the data bits are data or a command. A0 = "H": Indicates that D0 to D7 are display data. A0 = "L": Indicates that D0 to D7 are control data.
4	/WR (R/W)	When connected to an 8080 MPU, this is active LOW. (R/W) This terminal connects to the 8080 MPU /WR signal. The signals on the data bus are latched at the rising edge of the /WR signal. When connected to a 6800 Series MPU: This is the read/write control signal input terminal. When R/W = "H": Read. When R/W = "L": Write.
5	/RD (E)	When connected to an 8080 MPU, this is active LOW. (E) This pin is connected to the /RD signal of the 8080 MPU, and the ST7565S series data bus is in an output status when this signal is "L". When connected to a 6800 Series MPU, this is active HIGH. This is the 6800 Series MPU enable clock input terminal.
6	D0	This is an 8-bit bi-directional data bus that connects to an 8-bit or 16-bit standard MPU data bus.
7	D1	
8	D2	
9	D3	
10	D4	
11	D5	
12	D6	
13	D7	
14	VDD	Shared with the MPU power supply terminal VDD. (3.3 V)
15	VSS	This is a 0V terminal connected to the system GND.
16	VOUT	DC/DC voltage converter. Connect a capacitor between this terminal and VSS.

Pin No.	Symbol	Function										
17	CAP5-	DC/DC voltage converter. Connect a capacitor between this terminal and the CAP1+ terminal.										
18	CAP3-	DC/DC voltage converter. Connect a capacitor between this terminal and the CAP1+ terminal.										
19	CAP1+	DC/DC voltage converter. Connect a capacitor between this terminal and the CAP1+ terminal.										
20	CAP1-	DC/DC voltage converter. Connect a capacitor between this terminal and the CAP1+ terminal.										
21	CAP2-	DC/DC voltage converter. Connect a capacitor between this terminal and the CAP2+ terminal.										
22	CAP2+	DC/DC voltage converter. Connect a capacitor between this terminal and the CAP2+ terminal.										
23	CAP4-	DC/DC voltage converter. Connect a capacitor between this terminal and the CAP2+ terminal.										
24	VRS	This is the externally-input VREG power supply for the LCD power supply voltage regulator. These are only enabled for the models with the VREG external input option.										
25	V1	<p>Power This is a multi-level power supply for the liquid crystal drive. The voltage Supply applied is determined by the liquid crystal cell, and is changed through the use of a resistive voltage divided or through changing the impedance using an op. amp. Voltage levels are determined based on VDD, and must maintain the relative magnitudes shown below.</p> <p>$VDD (= V0) \geq V1 \geq V2 \geq V3 \geq V4 \geq V5$</p> <p>When the power supply turns ON, the internal power supply circuits produce the V1 to V4 voltages shown below. The voltagesettings are selected using the LCD bias set command.</p> <table border="1" data-bbox="531 1563 1147 1805"> <thead> <tr> <th></th> <th>1/65 DUTY</th> </tr> </thead> <tbody> <tr> <td>V1</td> <td>$1/9 * V5, 1/7 * V5$</td> </tr> <tr> <td>V2</td> <td>$2/9 * V5, 2/7 * V5$</td> </tr> <tr> <td>V3</td> <td>$7/9 * V5, 5/7 * V5$</td> </tr> <tr> <td>V4</td> <td>$8/9 * V5, 6/7 * V5$</td> </tr> </tbody> </table>		1/65 DUTY	V1	$1/9 * V5, 1/7 * V5$	V2	$2/9 * V5, 2/7 * V5$	V3	$7/9 * V5, 5/7 * V5$	V4	$8/9 * V5, 6/7 * V5$
	1/65 DUTY											
V1	$1/9 * V5, 1/7 * V5$											
V2	$2/9 * V5, 2/7 * V5$											
V3	$7/9 * V5, 5/7 * V5$											
V4	$8/9 * V5, 6/7 * V5$											
26	V2											
27	V3											
28	V4											
29	V5											

Pin No.	Symbol	Function															
30	VR	Output voltage regulator terminal. Provides the voltage between VDD and V5 through a resistive voltage divider. IRS = "L" : the V5 voltage regulator internal resistors are not used . IRS = "H" : the V5 voltage regulator internal resistors are used .															
31	C86	This is the MPU interface switch terminal. C86 = "H": 6800 Series MPU interface. C86 = "L": 8080 MPU interface.															
32	P/S	This is the parallel data input/serial data input switch terminal. P/S = "H": Parallel data input. P/S = "L": Serial data input. The following applies depending on the P/S status: <table border="1" data-bbox="507 831 1369 1025"> <thead> <tr> <th>P/S</th> <th>Data/Command</th> <th>Data</th> <th>Read/Write</th> <th>Serial Clock</th> </tr> </thead> <tbody> <tr> <td>"H"</td> <td>A0</td> <td>D0 to D7</td> <td>\overline{RD}, \overline{WR}</td> <td>X</td> </tr> <tr> <td>"L"</td> <td>A0</td> <td>SI (D7)</td> <td>Write only</td> <td>SCL (D6)</td> </tr> </tbody> </table> When P/S = "L", D0 to D5 may be "H", "L" or Open. RD (E) and WR (R/W) are fixed to either "H" or "L". With serial data input, It is impossible read data from RAM .	P/S	Data/Command	Data	Read/Write	Serial Clock	"H"	A0	D0 to D7	\overline{RD} , \overline{WR}	X	"L"	A0	SI (D7)	Write only	SCL (D6)
P/S	Data/Command	Data	Read/Write	Serial Clock													
"H"	A0	D0 to D7	\overline{RD} , \overline{WR}	X													
"L"	A0	SI (D7)	Write only	SCL (D6)													
33	/HPM	This is the power control terminal for the power supply circuit for liquid crystal drive. HPM = "H": Normal mode HPM = "L": High power mode															
34	IRS	This terminal selects the resistors for the V5 voltage level adjustment. IRS = "H": Use the internal resistors IRS = "L": Do not use the internal resistors. The V5 voltage level is regulated by an external resistive voltage divider attached to the VR terminal															

BL Pin No.	Symbol	Function
	A	Power supply for LED Backlight Anode input (VF=2.2V , IF=100 mA)
	K	Power supply for LED Backlight Cathode input (0 V)

2.3 Timing Characteristics

FOR 8080 Series MPU

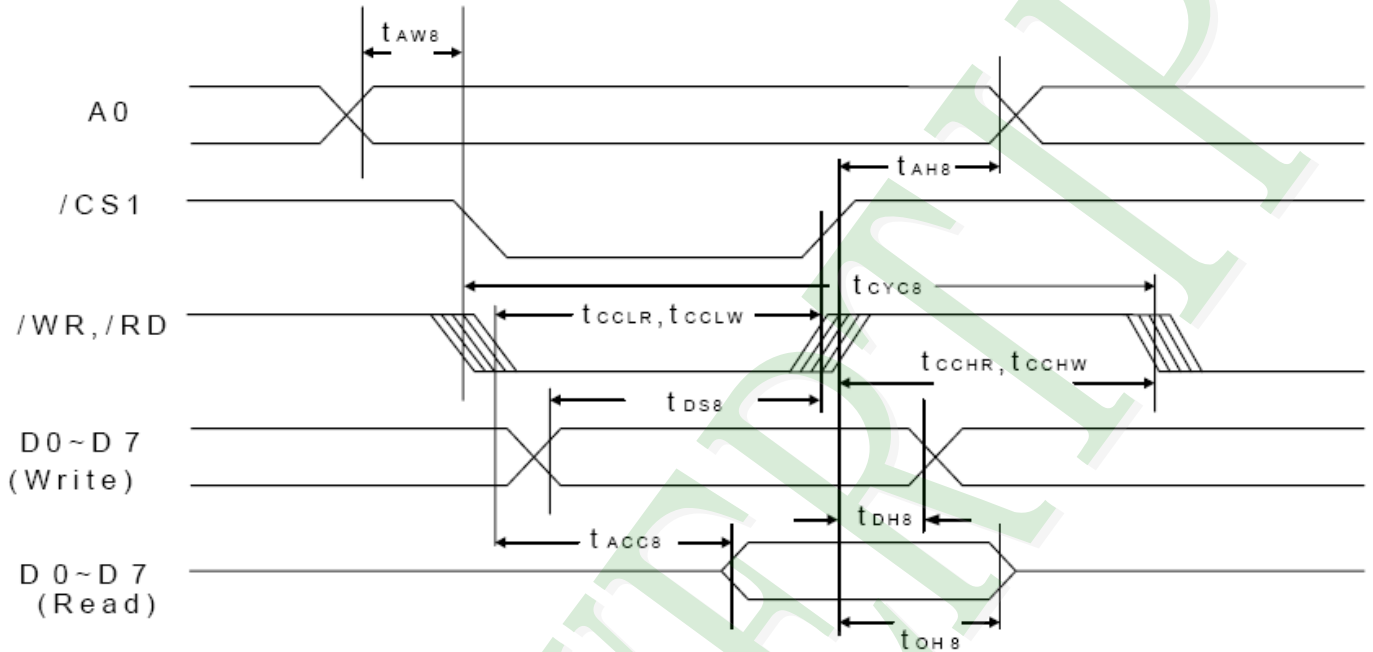

Item	Signal	Symbol	Condition	Rating		Units
				Min.	Max.	
Address hold time	A0	t_{AH8}		0	-	ns
Address setup time	A0	t_{AW8}		0	-	
System cycle time		t_{CYC8}		240	-	
Enable L pulse width (WRITE)	WR	t_{CCLW8}		80	-	
Enable H pulse width (WRITE)	WR	t_{CCHW8}		80	-	
Enable L pulse width (READ)	RD	t_{CCLR8}		140	-	
Enable H pulse width (READ)	RD	t_{CCHR8}		80	-	
WRITE Data setup time	D0	t_{DS8}		40	-	
WRITE Address hold time	to D7	t_{DH8}		0	-	
READ access time	D7	t_{ACC8}	$C_L=100\text{pF}$	-	70	
READ Output disable time		t_{OH8}	$C_L=100\text{pF}$	5	50	

FOR 6800Series MPU

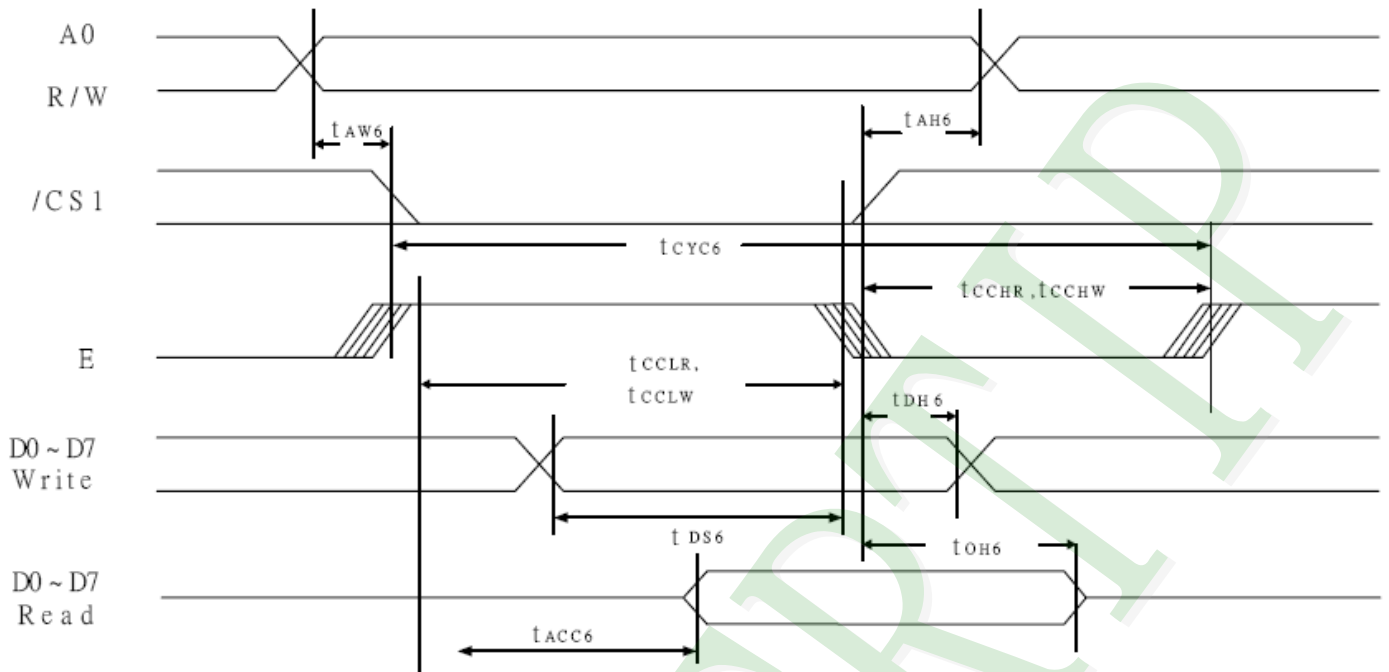

Item	Signal	Symbol	Condition	Rating		Units
				Min.	Max.	
Address hold time	A0	t_{AH6}		0	-	ns
Address setup time		t_{AW6}		0	-	
System cycle time		t_{CYC6}		240	-	
Enable L pulse width (WRITE)	WR	t_{EWLW}		80	-	
Enable H pulse width (WRITE)		t_{EWHW8}		80	-	
Enable L pulse width (READ)	RD	t_{EWLR8}		80	-	
Enable H pulse width (READ)		t_{EWHR}		140	-	
WRITE Data setup time	D0 to D7	t_{DS6}		40	-	
WRITE Address hold time		t_{DH6}		0	-	
READ access time		t_{ACC6}	$C_L=100pF$	-	70	
READ Output disable time		t_{OH6}	$C_L=100pF$	5	50	

Serial Interface

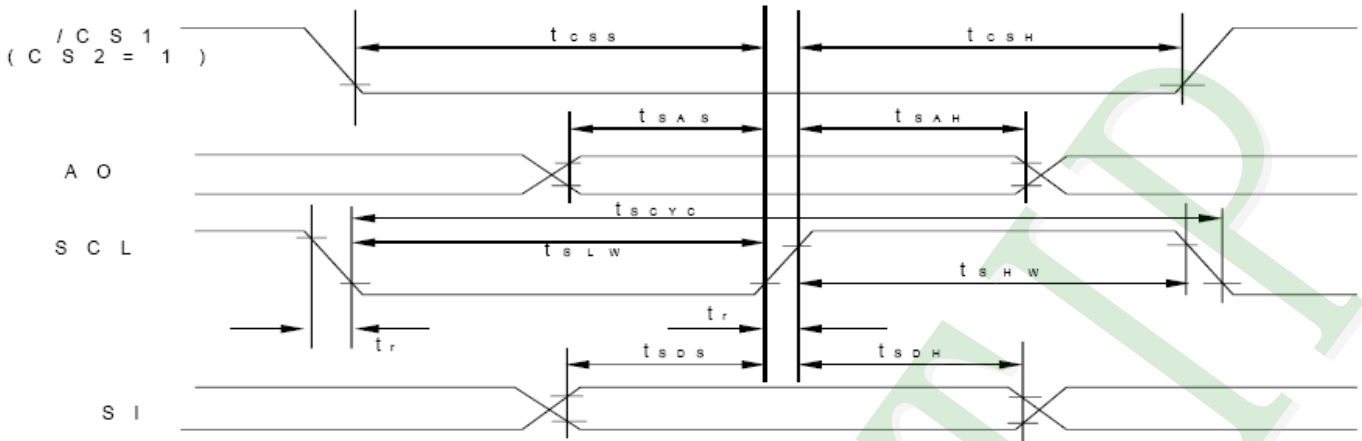

Item	Signal	Symbol	Condition	Rating		Units
				Min	Max	
Serial Clock Period	SCL	T_{SCYC}	-	100	-	ns
SCL "H" pulse with		T_{SHW}	-	50	-	
SCL "L" pulse with		T_{SLW}	-	50	-	
Address setup time	A0	T_{SAS}	-	20	-	
Address hold time		T_{SAH}	-	10	-	
Data setup time	SI	T_{SDS}	-	20	-	
Data hold time		T_{SDH}	-	10	-	
CS-SCL time	CS	T_{CSS}	-	40	-	
CS-SCL time		T_{CSH}	-	40	-	

Reset Timing

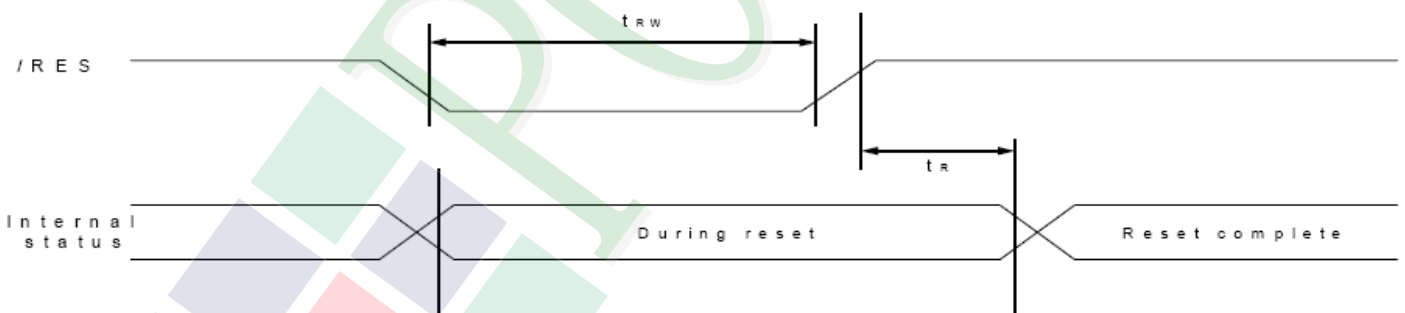

Item	Signal	Symbol	Condition	Rating			Units
				Min	Typ	Max	
Reset time	-	t_R	-	-	-	1.0	μs
Reset "L" pulse width	RES	t_{RW}	-	1.0	-	-	μs

2.4 Display Command

Instruction	RS	RW	D7	D6	D5	D4	D3	D2	D1	D0	Description	
Display ON/OFF	0	0	1	0	1	0	1	1	1	0/1	Turn on/off LCD panel.	
Display start line set	0	0	0	1	Display start address						Specify DDRAM line for COM0	
Page address set	0	0	1	0	1	1	Page address				Set page address	
Set column address MSB	0	0	0	0	0	1	Y7	Y6	Y5	Y4	Set column address MSB	
Set column address LSB	0	0	0	0	0	0	Y3	Y2	Y1	Y0	Set column address LSB	
Read status	0	1	BUSY	ADC	ON/OFF	RESET	0	0	0	0	Read the internal status	
Write display data	1	0	Write data									Write data into DDRAM
Read display data	1	1	Read data									Read data from DDRAM
ADC select	0	0	1	0	1	0	0	0	0	0/1	Select SEG output directional	
Display normal/reverse	0	0	1	0	1	0	0	1	1	0/1	Select normal/reverse display	
Display all points ON/OFF	0	0	1	0	1	0	0	1	0	0/1	Select normal/entire display ON	
LCD bias select	0	0	1	0	1	0	0	0	1	0/1	Select LCD bias	
Read/modify/write	0	0	1	1	1	0	0	0	0	0	Column address Increment	
End	0	0	1	1	1	0	1	1	1	0	Clear read/modify/write	
Reset	0	0	1	1	1	0	0	0	1	0	Initialize the internal functions	
Common output Mode select	0	0	1	1	0	0	0/1	x	x	x	Select COM output scan direction	
Power control	0	0	0	0	1	0	1	0/1	0/1	0/1	Control power circuit operation	
V5 voltage regulator internal resistor ratio set	0	0	0	0	1	0	0	Resistor ratio			Select internal resistance ratio of the regulator resistor	

Instruction	RS	RW	D7	D6	D5	D4	D3	D2	D1	D0	Description
Electronic volume mode set	0	0	1	0	0	0	0	0	0	1	Set reference voltage mode
Electronic volume regulator set	0	0	x	x	Electronic volume value						Set reference voltage register
Static indicator ON/OFF	0	0	1	0	1	0	1	1	0	0/1	Set static indicator mode
Static indicator register set	0	0	x	x	x	x	x	x	Mode		Set the flashing mode
Boosting ratio set	0	0	1	1	1	1	1	0	0	0	Select boosting ratio
	0	0	*	*	*	*	*	*	Mode		
Power save	-	-	-	-	-	-	-	-	-	-	Display OFF and Display all point ON compound command
NOP	0	0	1	1	1	0	0	0	1	1	N0n operation command

3. QUALITY ASSURANCE SYSTEM

3.1 Quality Assurance Flow Chart

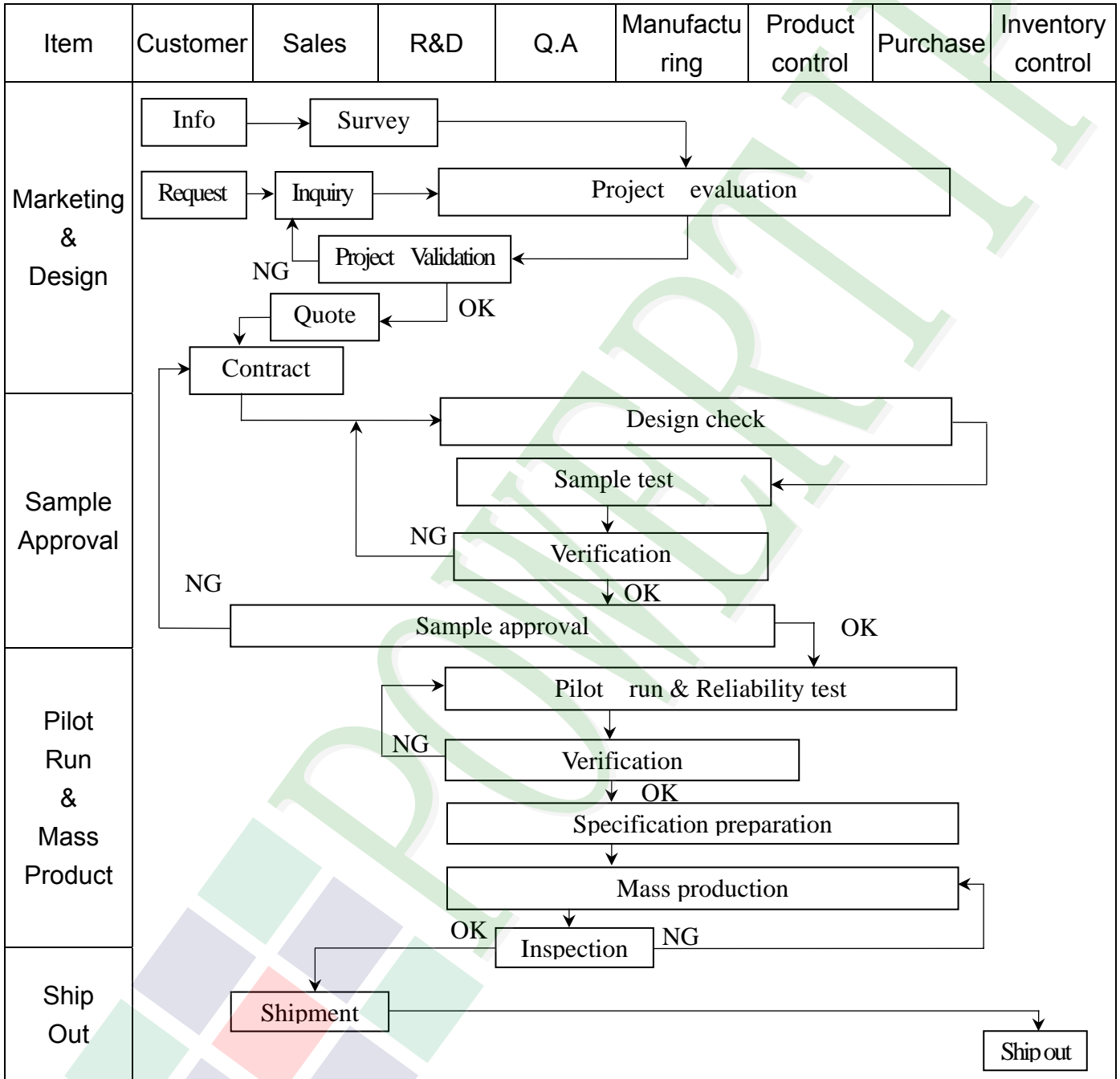

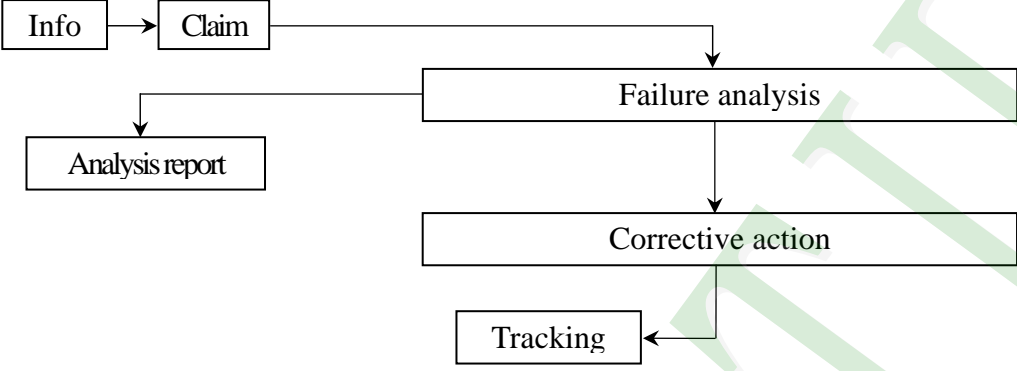
Item	Customer	Sales	R&D	Q.A	Manufacturing	Product control	Purchase	Inventory control
Sales Service	 <pre> graph TD Info[Info] --> Claim[Claim] Claim --> FA[Failure analysis] FA --> AR[Analysis report] FA --> CA[Corrective action] CA --> Tracking[Tracking] </pre>							
Q.A Activity	1. ISO 9001 Maintenance Activities 3. Equipment calibration 5. Standardization Management				2. Process improvement proposal 4. Education And Training Activities			

3.2. Inspection Specification

◆ Scope : The document shall be applied to LCD Module for Monotype and Color STN(Ver. B01).

◆ Inspection Standard : MIL-STD-105E Table Normal Inspection Single Sampling Level II .

◆ Equipment : Gauge 、 MIL-STD 、 Powertip Tester 、 Sample

◆ Defect Level : Major Defect AQL : 0.4 ; Minor Defect : AQL : 1.5 .

◆ OUT Going Defect Level : Sampling .

◆ Manner of appearance test :

(1). The test be under 20W×2 fluorescent light ' and distance of view must be at 30 cm.

(2). Standard of inspection : (Unit : mm)

(3). The test direction is base on about around 45° of vertical line. (Fig. 1)

(4). Definition of area . (Fig. 2)

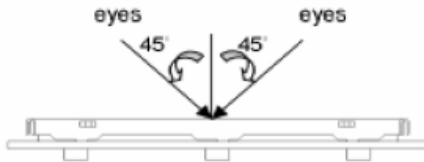

Fig.1

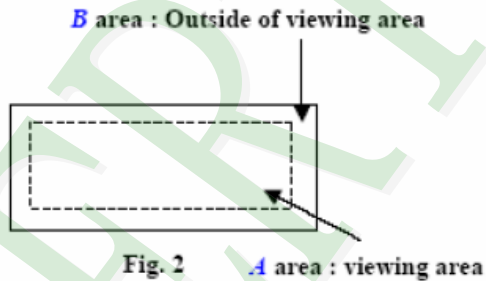
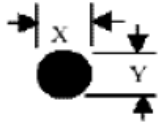
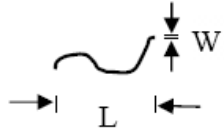
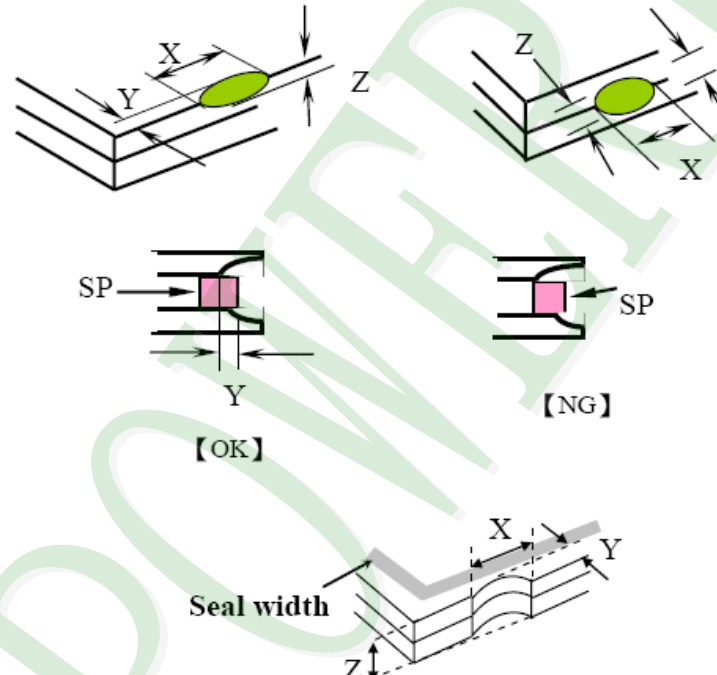

Fig. 2

◆ Specification:

NO	Item	Criterion	Level
01	Product condition	1. 1 The part number is inconsistent with work order of Production.	Major
		1. 2 Mixed production types.	Major
		1. 3 Assembled in inverse direction.	Major
02	Quantity	2. 1 The quantity is inconsistent with work order of production.	Major
03	Outline dimension	3. 1 Product dimension and structure must conform to Structure diagram.	Major
04	Electrical Testing	4. 1 Missing line character and icon.	Major
		4. 2 No function or no display.	Major
		4. 3 Output data is error.	Major
		4. 4 LCD viewing angle defect.	Major
		4. 5 Current consumption exceeds product specifications.	Major

NO	Item	Criterion	Level																																					
05	<p>Black or white dot、scratch、contamination</p> <p>Round type</p>  <p>$\Phi = (x+y)/2$</p> <p>Line type</p> 	<p>5. 1 Round type:</p> <p>5. 1. 1 display only :</p> <ul style="list-style-type: none"> • White and black spots on display ≤ 0.30 mm , no more than 4 white or black spots present. • Densely spaced : NO more than two spots or lines within 3 mm. <p>5. 1. 2 Non-display :</p> <table border="1"> <thead> <tr> <th rowspan="2">Dimension (diameter : Φ)</th> <th colspan="2">Acceptance (Q'ty)</th> </tr> <tr> <th>A area</th> <th>B area</th> </tr> </thead> <tbody> <tr> <td>$\Phi \leq 0.10$</td> <td colspan="2">Accept no dense</td> </tr> <tr> <td>$0.10 < \Phi \leq 0.20$</td> <td>3</td> <td rowspan="2">Ignore</td> </tr> <tr> <td>$0.20 < \Phi \leq 0.30$</td> <td>2</td> </tr> <tr> <td>Total quantity</td> <td colspan="2">4</td> </tr> </tbody> </table> <p>5. 1. 3 Line type:</p> <table border="1"> <thead> <tr> <th colspan="2">Dimension</th> <th colspan="2">Acceptance (Q'ty)</th> </tr> <tr> <th>Length (L)</th> <th>Width (W)</th> <th>A area</th> <th>B area</th> </tr> </thead> <tbody> <tr> <td>---</td> <td>$W \leq 0.03$</td> <td>Accept no dense</td> <td rowspan="3">Ignore</td> </tr> <tr> <td>$L \leq 3.0$</td> <td>$0.03 < W \leq 0.05$</td> <td rowspan="2">4</td> </tr> <tr> <td>$L \leq 2.5$</td> <td>$0.05 < W \leq 0.075$</td> </tr> <tr> <td>---</td> <td>$W > 0.075$</td> <td colspan="2">As round type</td> </tr> </tbody> </table>	Dimension (diameter : Φ)	Acceptance (Q'ty)		A area	B area	$\Phi \leq 0.10$	Accept no dense		$0.10 < \Phi \leq 0.20$	3	Ignore	$0.20 < \Phi \leq 0.30$	2	Total quantity	4		Dimension		Acceptance (Q'ty)		Length (L)	Width (W)	A area	B area	---	$W \leq 0.03$	Accept no dense	Ignore	$L \leq 3.0$	$0.03 < W \leq 0.05$	4	$L \leq 2.5$	$0.05 < W \leq 0.075$	---	$W > 0.075$	As round type		Minor
Dimension (diameter : Φ)	Acceptance (Q'ty)																																							
	A area	B area																																						
$\Phi \leq 0.10$	Accept no dense																																							
$0.10 < \Phi \leq 0.20$	3	Ignore																																						
$0.20 < \Phi \leq 0.30$	2																																							
Total quantity	4																																							
Dimension		Acceptance (Q'ty)																																						
Length (L)	Width (W)	A area	B area																																					
---	$W \leq 0.03$	Accept no dense	Ignore																																					
$L \leq 3.0$	$0.03 < W \leq 0.05$	4																																						
$L \leq 2.5$	$0.05 < W \leq 0.075$																																							
---	$W > 0.075$	As round type																																						
06	Polarizer Bubble	<table border="1"> <thead> <tr> <th rowspan="2">Dimension (diameter : Φ)</th> <th colspan="2">Acceptance (Q'ty)</th> </tr> <tr> <th>A area</th> <th>B area</th> </tr> </thead> <tbody> <tr> <td>$\Phi \leq 0.20$</td> <td colspan="2">Accept no dense</td> </tr> <tr> <td>$0.20 < \Phi \leq 0.50$</td> <td>3</td> <td rowspan="3">Ignore</td> </tr> <tr> <td>$0.50 < \Phi \leq 1.00$</td> <td>2</td> </tr> <tr> <td>$\Phi > 1.00$</td> <td>0</td> </tr> <tr> <td>Total quantity</td> <td colspan="2">4</td> </tr> </tbody> </table>	Dimension (diameter : Φ)	Acceptance (Q'ty)		A area	B area	$\Phi \leq 0.20$	Accept no dense		$0.20 < \Phi \leq 0.50$	3	Ignore	$0.50 < \Phi \leq 1.00$	2	$\Phi > 1.00$	0	Total quantity	4		Minor																			
Dimension (diameter : Φ)	Acceptance (Q'ty)																																							
	A area	B area																																						
$\Phi \leq 0.20$	Accept no dense																																							
$0.20 < \Phi \leq 0.50$	3	Ignore																																						
$0.50 < \Phi \leq 1.00$	2																																							
$\Phi > 1.00$	0																																							
Total quantity	4																																							

NO	Item	Criterion	Level						
07	The crack of glass	<p>Symbols :</p> <p>X : The length of crack Z : The thickness of crack t : The thickness of glass</p> <p>Y : The width of crack. W : terminal length a : LCD side length</p>	Minor						
		<p>7.1 General glass chip :</p> <p>7.1.1 Chip on panel surface and crack between panels:</p>  <table border="1" data-bbox="502 1500 1300 1792"> <thead> <tr> <th>X</th> <th>Y</th> <th>Z</th> </tr> </thead> <tbody> <tr> <td>$\leq a$</td> <td>Crack can't enter viewing area</td> <td>$\leq 1/2 t$</td> </tr> <tr> <td>$\leq a$</td> <td>Crack can't exceed the half of SP width.</td> <td>$1/2 t < Z \leq 2 t$</td> </tr> </tbody> </table>		X	Y	Z	$\leq a$	Crack can't enter viewing area	$\leq 1/2 t$
X	Y	Z							
$\leq a$	Crack can't enter viewing area	$\leq 1/2 t$							
$\leq a$	Crack can't exceed the half of SP width.	$1/2 t < Z \leq 2 t$							

◆ Specification For Monotype and Color STN :

(Ver. B01)

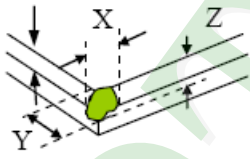
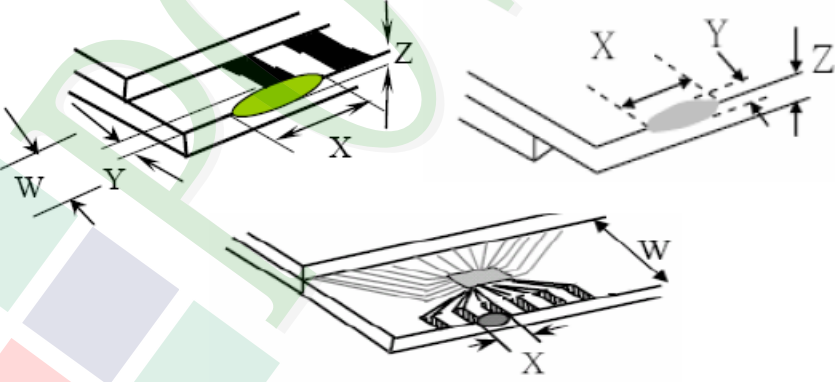
NO	Item	Criterion	Level									
07	The crack of glass	<p>Symbols :</p> <p>X : The length of crack Z : The thickness of crack t : The thickness of glass</p> <p>Y : The width of crack. W : terminal length a : LCD side length</p> <hr/> <p>7.1.2 Corner crack :</p>  <table border="1" data-bbox="502 817 1316 1108"> <thead> <tr> <th>X</th> <th>Y</th> <th>Z</th> </tr> </thead> <tbody> <tr> <td>$\leq 1/5 a$</td> <td>Crack can't enter viewing area</td> <td>$Z \leq 1/2 t$</td> </tr> <tr> <td>$\leq 1/5 a$</td> <td>Crack can't exceed the half of SP width.</td> <td>$1/2 t < Z \leq 2 t$</td> </tr> </tbody> </table>	X	Y	Z	$\leq 1/5 a$	Crack can't enter viewing area	$Z \leq 1/2 t$	$\leq 1/5 a$	Crack can't exceed the half of SP width.	$1/2 t < Z \leq 2 t$	Minor
		X	Y	Z								
$\leq 1/5 a$	Crack can't enter viewing area	$Z \leq 1/2 t$										
$\leq 1/5 a$	Crack can't exceed the half of SP width.	$1/2 t < Z \leq 2 t$										
<p>7.2 Protrusion over terminal :</p> <p>7.2.1 Chip on electrode pad :</p>  <table border="1" data-bbox="470 1691 1252 1870"> <thead> <tr> <th></th> <th>X</th> <th>Y</th> <th>Z</th> </tr> </thead> <tbody> <tr> <td>Front</td> <td>$\leq a$</td> <td>$\leq 1/2 W$</td> <td>$\leq t$</td> </tr> <tr> <td>Back</td> <td colspan="3">Neglect</td> </tr> </tbody> </table>		X	Y	Z	Front	$\leq a$	$\leq 1/2 W$	$\leq t$	Back	Neglect		
	X	Y	Z									
Front	$\leq a$	$\leq 1/2 W$	$\leq t$									
Back	Neglect											

◆ Specification For Monotype and Color STN :

(Ver. B01)

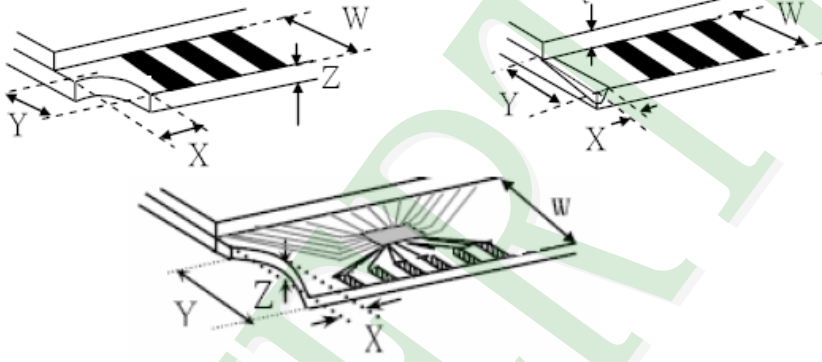
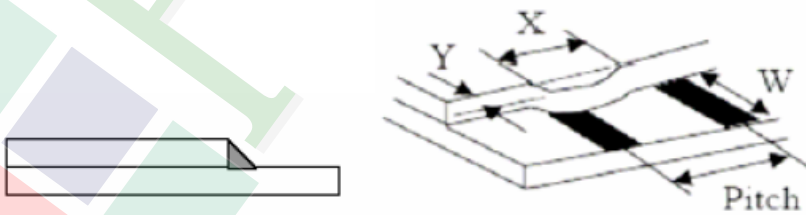
NO	Item	Criterion	Level									
07	The crack of glass	<p>Symbols :</p> <p>X : The length of crack Z : The thickness of crack t : The thickness of glass</p> <p>Y : The width of crack. W : terminal length a : LCD side length</p>	Minor									
		<p>7.2.2 Non-conductive portion :</p>  <table border="1" data-bbox="582 1052 1204 1205"> <thead> <tr> <th>X</th> <th>Y</th> <th>Z</th> </tr> </thead> <tbody> <tr> <td>$\leq 1/3 a$</td> <td>$\leq W$</td> <td>$\leq t$</td> </tr> </tbody> </table> <p>⊙ If the chipped area touches the ITO terminal, over 2/3 of the ITO must remain and be inspected according to electrode terminal specifications.</p> <p>7.2.3 Glass remain :</p>  <table border="1" data-bbox="502 1736 1189 1870"> <thead> <tr> <th>X</th> <th>Y</th> <th>Z</th> </tr> </thead> <tbody> <tr> <td>$\leq a$</td> <td>$\leq 1/3 W$</td> <td>$\leq t$</td> </tr> </tbody> </table>		X	Y	Z	$\leq 1/3 a$	$\leq W$	$\leq t$	X	Y	Z
X	Y	Z										
$\leq 1/3 a$	$\leq W$	$\leq t$										
X	Y	Z										
$\leq a$	$\leq 1/3 W$	$\leq t$										

◆ Specification For Monotype and Color STN :

(Ver. B01)

NO	Item	Criterion	Level
08	Backlight elements	8. 1 Backlight can't work normally.	Major
		8. 2 Backlight doesn't light or color is wrong.	Major
		8. 3 Illumination source flickers when lit.	Major
09	General appearance	9. 1 Pin type must match type in specification sheet.	Major
		9. 2 No short circuits in components on PCB or FPC.	Major
		9. 3 Product packaging must the same as specified on packaging specification sheet.	Minor
		9. 4 The folding and peeled off in polarizer are not acceptable.	Minor
		9. 5 The PCB or FPC between B/L assembled distance (PCB or FPC) is ≤ 1.5 mm.	Minor

4. RELIABILITY TEST

4.1 Reliability Test Condition

(Ver.B01)

NO.	TEST ITEM	TEST CONDITION										
1	High Temperature Storage Test	Keep in +80 ±2°C 96 hrs Surrounding temperature, then storage at normal condition 4hrs.										
2	Low Temperature Storage Test	Keep in -30 ±2°C 96 hrs Surrounding temperature, then storage at normal condition 4hrs.										
3	High Temperature / High Humidity Storage Test	Keep in +60 °C / 90% R.H duration for 96 hrs Surrounding temperature, then storage at normal condition 4hrs. (Excluding the polarizer)										
4	Temperature Cycling Storage Test	<p style="text-align: center;"> $-30^{\circ}\text{C} \rightarrow +25^{\circ}\text{C} \rightarrow +80^{\circ}\text{C} \rightarrow +25^{\circ}\text{C}$ (30mins) (5mins) (30mins) (5mins) \longleftarrow 10 Cycle \longrightarrow </p> Surrounding temperature, then storage at normal condition 4hrs.										
5	ESD Test	Air Discharge: Apply 2 KV with 5 times Discharge for each polarity +/-										
		Contact Discharge: Apply 250 V with 5 times discharge for each polarity +/-										
		1. Temperature ambience : 15°C ~ 35°C 2. Humidity relative : 30% ~ 60% 3. Energy Storage Capacitance(Cs+Cd) : 150pF±10% 4. Discharge Resistance(Rd) : 330Ω±10% 5. Discharge, mode of operation : Single Discharge (time between successive discharges at least 1 sec) (Tolerance if the output voltage indication : ±5%)										
6	Vibration Test (Packaged)	1. Sine wave 10~55 Hz frequency (1 min/sweep) 2. The amplitude of vibration : 1.5 mm 3. Each direction (X、Y、Z) duration for 2 Hrs										
7	Drop Test (Packaged)	<table border="1" style="width: 100%; text-align: center;"> <thead> <tr> <th>Packing Weight (Kg)</th> <th>Drop Height (cm)</th> </tr> </thead> <tbody> <tr> <td>0 ~ 45.4</td> <td>122</td> </tr> <tr> <td>45.4 ~ 90.8</td> <td>76</td> </tr> <tr> <td>90.8 ~ 454</td> <td>61</td> </tr> <tr> <td>Over 454</td> <td>46</td> </tr> </tbody> </table>	Packing Weight (Kg)	Drop Height (cm)	0 ~ 45.4	122	45.4 ~ 90.8	76	90.8 ~ 454	61	Over 454	46
		Packing Weight (Kg)	Drop Height (cm)									
0 ~ 45.4	122											
45.4 ~ 90.8	76											
90.8 ~ 454	61											
Over 454	46											
	Drop Direction : ※1 corner / 3 edges / 6 sides each 1time											

5. PRECAUTION RELATING PRODUCT HANDLING

5.1 SAFETY

- 5.1.1 If the LCD panel breaks , be careful not to get the liquid crystal to touch your skin.
- 5.1.2 If the liquid crystal touches your skin or clothes , please wash it off immediately by using soap and water.

5.2 HANDLING

- 5.2.1 Avoid any strong mechanical shock which can break the glass.
- 5.2.2 Avoid static electricity which can damage the CMOS LSI—When working with the module , be sure to ground your body and any electrical equipment you may be using.
- 5.2.3 Do not remove the panel or frame from the module.
- 5.2.4 The polarizing plate of the display is very fragile. So , please handle it very carefully ,do not touch , push or rub the exposed polarizing with anything harder than an HB pencil lead (glass , tweezers , etc.)
- 5.2.5 Do not wipe the polarizing plate with a dry cloth , as it may easily scratch the surface of plate.
- 5.2.6 Do not touch the display area with bare hands , this will stain the display area.
- 5.2.7 Do not use ketonics solvent & aromatic solvent. Use with a soft cloth soaked with a cleaning naphtha solvent.
- 5.2.8 To control temperature and time of soldering is $320\pm 10^{\circ}\text{C}$ and 3-5 sec.
- 5.2.9 To avoid liquid (include organic solvent) stained on LCM .

5.3 STORAGE

- 5.3.1 Store the panel or module in a dark place where the temperature is $25^{\circ}\text{C} \pm 5^{\circ}\text{C}$ and the humidity is below 65% RH.
- 5.3.2 Do not place the module near organics solvents or corrosive gases.
- 5.3.3 Do not crush , shake , or jolt the module.

5.4 TERMS OF WARRANTY

- 5.4.1 Applicable warrant period
The period is within thirteen months since the date of shipping out under normal using and storage conditions.
- 5.4.2 Unaccepted responsibility
This product has been manufactured to your company's specification as a part for use in your company's general electronic products. It is guaranteed to perform according to delivery specifications. For any other use apart from general electronic equipment , we cannot take responsibility if the product is used in nuclear power control equipment , aerospace equipment , fire and security systems or any other applications in which there is a direct risk to human life

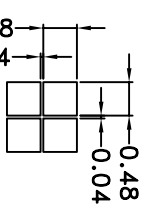
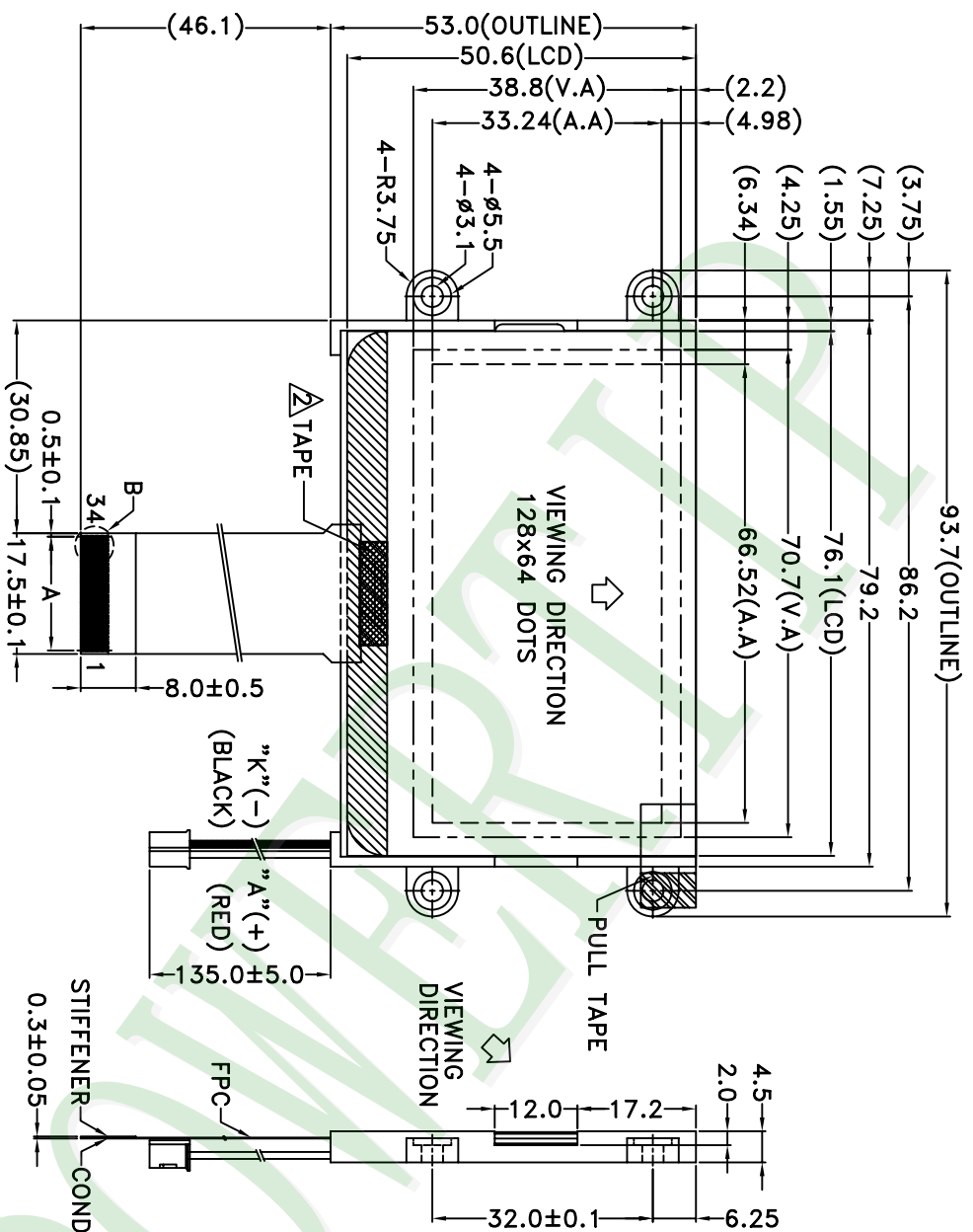

DETAIL DOTS
SCALE: 10/1

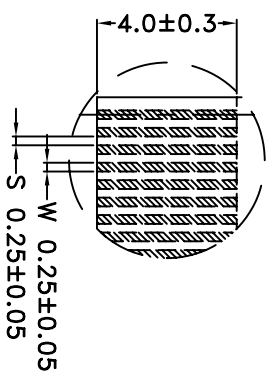

DETAIL B
SCALE: 5/1

NOTE:

1. THE TOLERANCE UNLESS CLASSIFIED ±0.2mm
2. LCD TYPE : STN (YELLOW GREEN)
3. VIEWING DIRECTION : 6 O'CLOCK
4. DISPLAY MODE : POSITIVE / TRANSPARENT
5. Top: -20°~70° , Tst: -30°~80°
6. A=P0.5x33=16.5±0.05
7. IC=ST7565S-G

007		PART NO:	PE12864LRU-022-H-Q	久正光電股份有限公司 POWER TIP TECHNOLOGY CORPORATION	Design	Sally	(3)	Surface	公差標準 (mm)	精細
006		DRAWING NAME:	JLMD-PE12864LRU-022-H-Q		Check	Terry		Unit		
005		TITLE:	LCD Module Drawing	Approve	Ryan	Scale	1:1	Thickness	4 ~ 4	-
004						Page	1/1	Quantity	16 ~ 16	-
003									63 ~ 63	-
002									250 ~ 250	-
001									250 ~ 1000	-

REV	REV BY	REVISER	DATE
001	NEW DRAWING		

Ver.002

Documents NO. JPKG-PE12864LRU-022-H-Q

LCM包裝規格書

LCM Packaging Specifications

(For Tray)

Approve	Check	Contact
Ryan	Terry	Sally

1.包裝材料規格表 (Packaging Material) : (per carton)

No.	Item	Model	Dimensions (mm)	1Pcs Weight	Quantity	Total Weight
1	成品 (LCM)	PE12864LRU-022-H-Q	93.7 X 53.0	0.027	144	3.888
2	多層薄膜(1)POF	OTFILM0BA03ABA	19"X350X0.015	—	6	—
3	TRAY 盤 (2)Tray	TY12806422TZBA	352 X 260 X 16.8	0.1	24	2.4
4	內盒(3)Product Box	BX36627063ABBA	366 X 270 X 66	0.2692	6	1.6152
5	保利龍板(4)Polylon board	OTPLB00PL08ABA	550 X 393 X 20	0.0284	2	0.0568
6	外紙箱(5)Carton	BX57041027CCBA	570 X 410 X 265	1.4208	1	1.4208
7						
8						
9						

2. 一 整箱總重量 (Total LCD Weight in carton) : 9.38 Kg±10%
3. 單箱數量規格表 (Packaging Specifications and Quantity) :
- | | | | | | |
|---|----|---------------|---|---|-----|
| (1) LCM quantity per box : no per tray | 8 | x no of tray | 3 | = | 24 |
| (2) Total LCM quantity in carton : quantity per box | 24 | x no of boxes | 6 | | 144 |

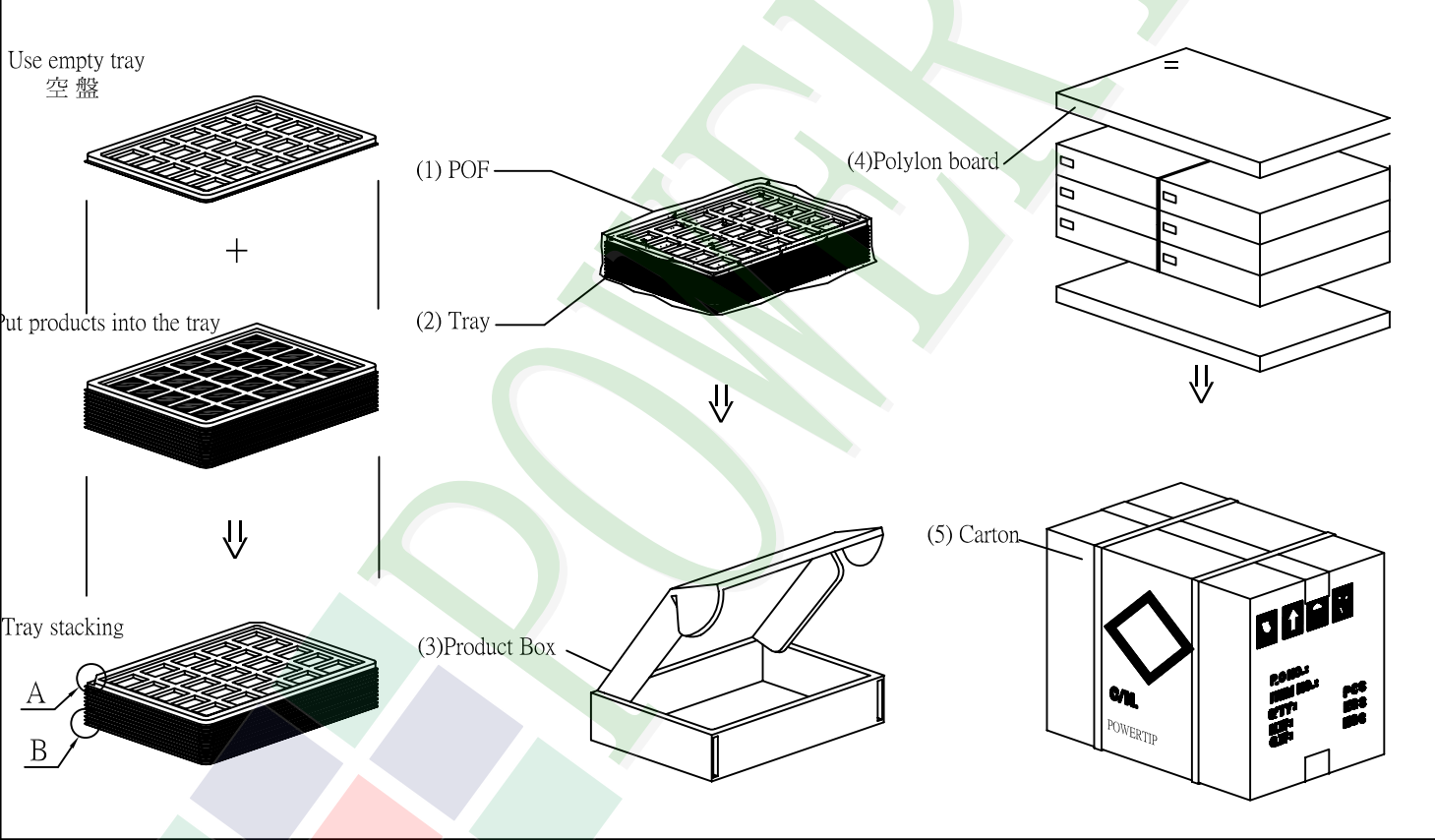

特 記 事 項 (REMARK)

4. Label Specifications :
依廠內標準作業

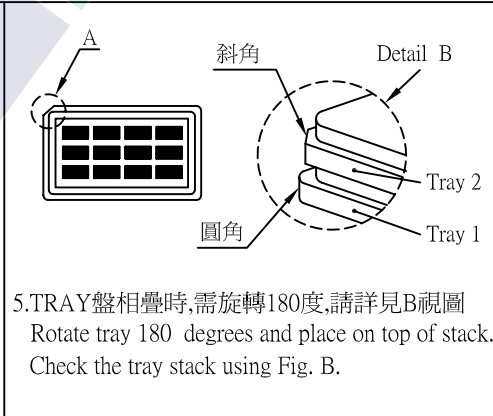

6. 可適用於單品包裝
It's also suitable to Panel