

SPECIFICATIONS

CUSTOMER	:	CES008
SAMPLE CODE	:	SE12864WRF-042HL4Q
MASS PRODUCTION CODE	:	PE12864WRF-042HL4Q
SAMPLE VERSION	:	01
SPECIFICATIONS EDITION	:	003
DRAWING NO. (Ver.)	:	JLMD-PE12864WRF-042HL4Q_001
PACKAGING NO. (Ver.)	:	JPKG-PE12864WRF-042HL4Q_001

Customer Approved

Date:

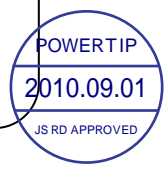

Approved	Checked	Designer
閔偉 Ryan	戴進霞 Una	劉進 Lori

- Preliminary specification for design input
- Specification for sample approval

POWERTIP TECH. CORP.

Headquarters: No.8, 6 th Road, Taichung Industrial Park, Taichung, Taiwan 台中市 407 工業區六路 8 號	TEL: 886-4-2355-8168 FAX: 886-4-2355-8166	E-mail: sales@powertip.com.tw Http:// www.powertip.com.tw
--	--	--



Contents

1. SPECIFICATIONS

- 1.1 Features
- 1.2 Mechanical Specifications
- 1.3 Absolute Maximum Ratings
- 1.4 DC Electrical Characteristics
- 1.5 Optical Characteristics
- 1.6 Backlight Characteristics

2. MODULE STRUCTURE

- 2.1 Counter Drawing
- 2.2 Interface Pin Description
- 2.3 Timing Characteristics
- 2.4 Display command
- 2.5 Jumper

3. QUALITY ASSURANCE SYSTEM

- 3.1 Quality Assurance Flow Chart
- 3.2 Inspection Specification

4. RELIABILITY TEST

- 4.1 Reliability Test Condition

5. PRECAUTION RELATING PRODUCT HANDLING

- 5.1 Safety
- 5.2 Handling
- 5.3 Storage
- 5.4 Terms of Warranty

- Appendix: 1. LCM Drawing
2. Packaging

1. SPECIFICATIONS

1.1 Features

Item	Standard Value
Display Type	128*64 Dots
LCD Type	FSTN, Positive, Transflective
Driver Condition	LCD Module : 1/65 Duty , 1/9 Bias
Viewing Direction	6 O'clock
Backlight	White LED B/L
Weight	29.7g
Interface	Parallel 8080 Series MPU Interface
Other(controller / driver IC)	ST7567
ROHS	THIS PRODUCT CONFORMS THE ROHS OF PTC Detail information please refer web side : http://www.powertip.com.tw/news/LatestNews.asp

1.2 Mechanical Specifications

Item	Standard Value	Unit
Outline Dimension	80.0(L) *54.0(w) (except FPC length) * 9.7(H)	mm
Viewing Area	70.7 (W) * 38.8 (L)	mm
Active Area	66.545(W) *33.265 (L)	mm
Dot Size	0.505 (W) * 0.505 (L)	mm
Dot Pitch	0.52(W) * 0.52 (L)	mm

Note : For detailed information please refer to LCM drawing

1.3 Absolute Maximum Ratings

Item	Symbol	Condition	Min.	Max.	Unit
Power Supply Voltage	V _{DD}	-	-0.3	3.6	V
LCD Driver Supply Voltage	VEE-VSS	-	-0.3	16	V
Operating Temperature	T _{OP}	-	-20	+70	°C
Storage Temperature	T _{ST}	-	-30	+80	°C
Storage Humidity	H _D	Ta < 60 °C	-	90	%RH

1.4 DC Electrical Characterist

VDD = 3.0±0.3V, VSS = 0V, Ta = 25°C

Item	Symbol	Condition	Min.	Typ.	Max.	Unit
Logic Supply Voltage	VDD	-	2.7	3.0	3.3	V
“H” Input Voltage	VIH	-	0.7 VDD	-	VDD	V
“L” Input Voltage	VIL	-	Vss	-	0.3VDD	V
“H” Output Voltage	VOH	-	0.8 VDD	-	VDD	V
“L” Output Voltage	VOL	-	Vss	-	0.2VDD	V
Supply Current	IDD	VDD=3.0V; VOP= 8.5V; Pattern= Horizontal line *1	-	1.0	1.5	
LCM Driver Voltage	Vop	-20°C	8.5	8.7	8.9	V
		25°C *2	8.2	8.5	8.8	
		+70°C	7.8	8.0	8.2	

NOTE: *1 The Maximum current display;

*2 The VOP is C10's voltage

1.5 Optical Characteristics

LCD Panel: $V_{LCD}=8.5V$, 1/65Duty, 1/9Bias, $T_a=25^{\circ}C$

Item	Symbol	Conditions	Min.	Typ.	Max.	Unit	Reference
Response Time	Rise	tr	-	100	150	ms	Note2
	Fall	tf	-	250	375		
Viewing angle range	Top	$\Theta Y+$	-	40	-	Deg.	Notes 1
	Bottom	$\Theta Y-$	-	40	-		
	Left	$\Theta X-$	-	45	-		
	Right	$\Theta X+$	-	45	-		
Contrast Ratio	C	$\theta = 0^{\circ}$, $\varnothing = 270^{\circ}$	4	5	-	-	Note 3
Average Brightness (with LCD) *2	IV	IF= 160mA	50	100	-	cd/m2	Note 4
CIE Color Coordinate (With LCD) *2	X		0.23	0.28	0.33	-	
	Y		0.26	0.31	0.36		
Uniformity *1	ΔB		70	-	-	%	

Note 4 :

1 : $\Delta B = B(\min) / B(\max) * 100\%$

2 : Measurement Condition for Optical Characteristics:

a : Environment: $25^{\circ}C \pm 5^{\circ}C$ / $60 \pm 20\%R.H$, no wind, dark room below 10 Lux at typical lamp current and typical operating frequency.

b : Measurement Distance: 500 ± 50 mm, ($\theta = 0^{\circ}$)

c : Equipment: TOPCON BM-7 fast, (field 1°), after 10 minutes operation.

d : The uncertainty of the C.I.E coordinate measurement ± 0.01 , Average Brightness $\pm 4\%$

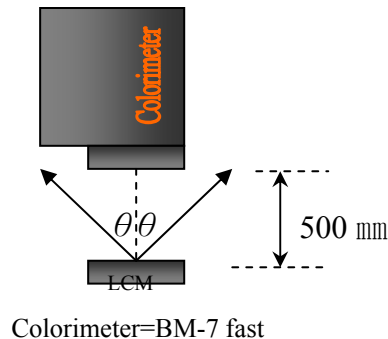
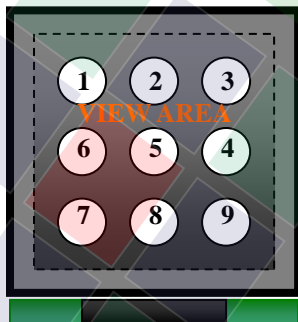

Note 1.

Optical characteristics-2

Viewing angle

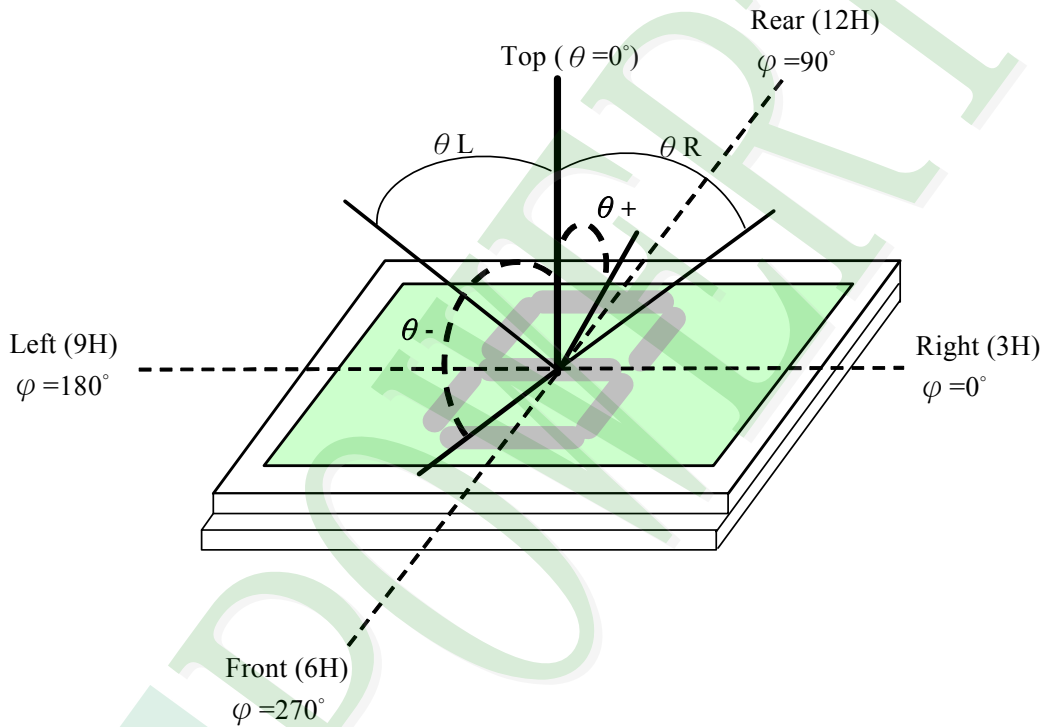

Viewing angle

Note 2.

Optical characteristics-3

Fig.2 Definition of response time

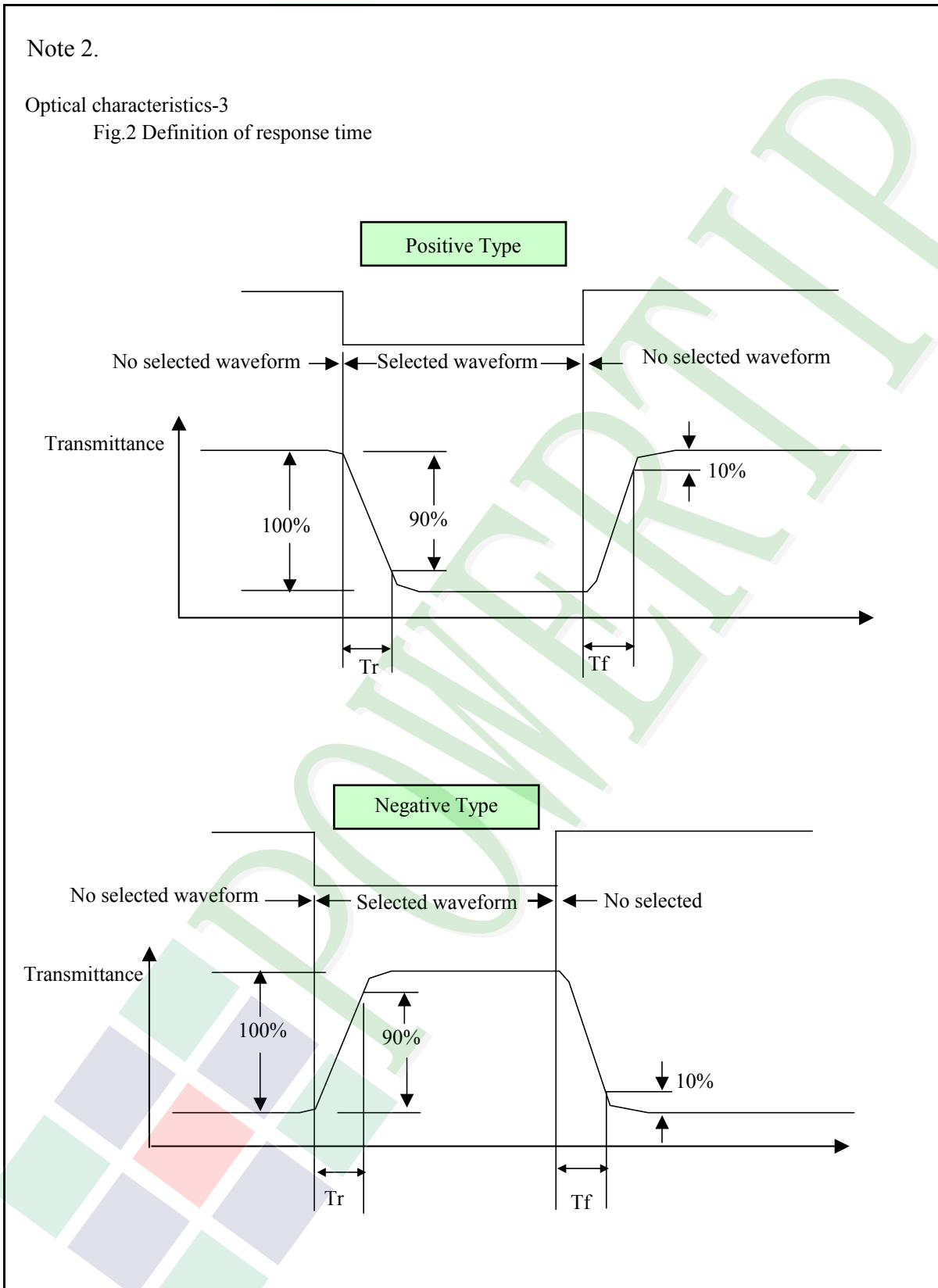

Electrical characteristics-2

※2 Drive waveform

V_{op} : Drive voltage

f_F : Frame frequency

$1/B$: Bias

f_D : Drive frequency

N : Duty

(1) Selected waveform

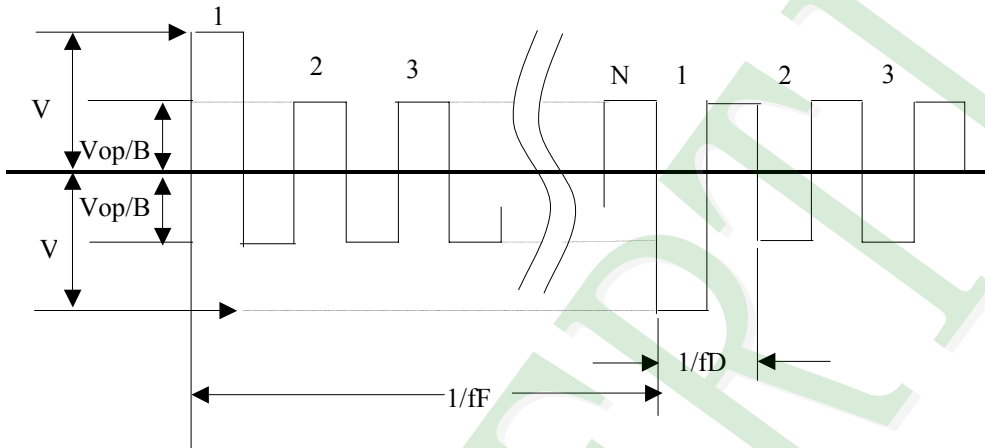

(2) Non- Selected wave form

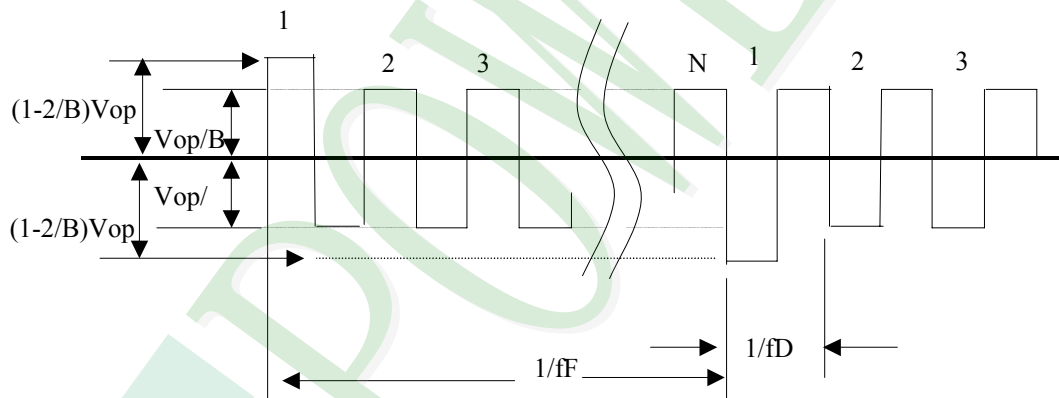

Note:

Frame frequency is defined as follows: Common side supply voltage peak - to - peak / 2 = 1 period

Note 3. : Definition of Vth

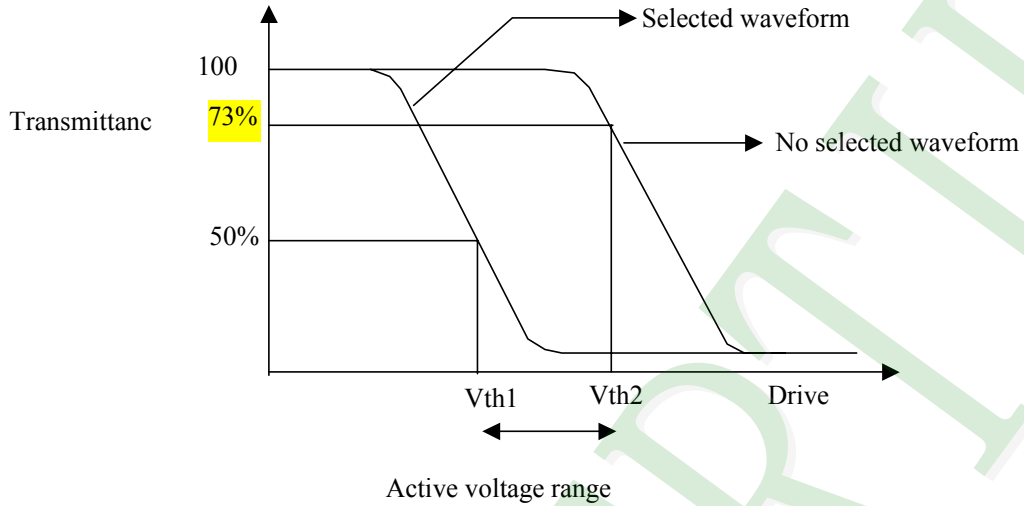

	Vth1	Vth2
View direction	10°	40°
Drive waveform	(Selected waveform)	(No selected waveform)
Transmittance	50%	73%

※1 Contrast ratio
= (Brightness in OFF state) / (Brightness in ON state)

Outline of Electro-Optical Characteristics Measuring System

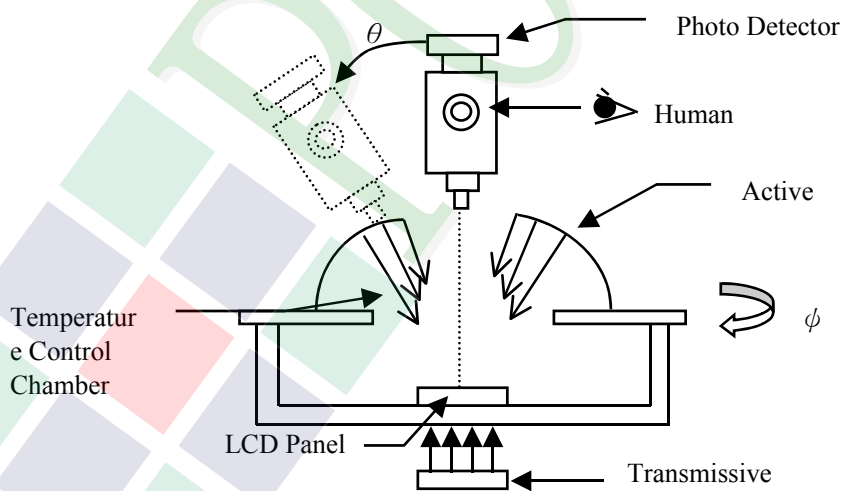

1.6 Backlight Characteristics

LCD Module with LED Backlight

Maximum Ratings

Item	Symbol	Conditions	Min.	Max.	Unit
Forward Current	IF	Ta =25°C	-	240	mA
Reverse Voltage	VR	Ta =25°C	-	5	V
Power Dissipation	PD	Ta =25°C	-	1.25	W

Electrical / Optical Characteristics

Ta =25°C

Item	Symbol	Conditions	Min.	Typ.	Max.	Unit
Forward Voltage	VF	IF= 160mA	-	5.0	5.2	V
Reverse Current	IR	VR= 5 V	-	-	16	uA
Average Brightness	IV	IF= 160mA	300	370	-	cd/m2
CIE Color Coordinate	X	IF= 160mA	0.255	-	0.340	-
	Y		0.265	-	0.350	
Uniformity*1	△B	IF= 160 mA	70	-	-	%
Color	WHITE					

2. MODULE STRUCTURE

2.1 Counter Drawing

2.1.1 LCM Mechanical Diagram

* See Appendix

2.1.2 Block Diagram

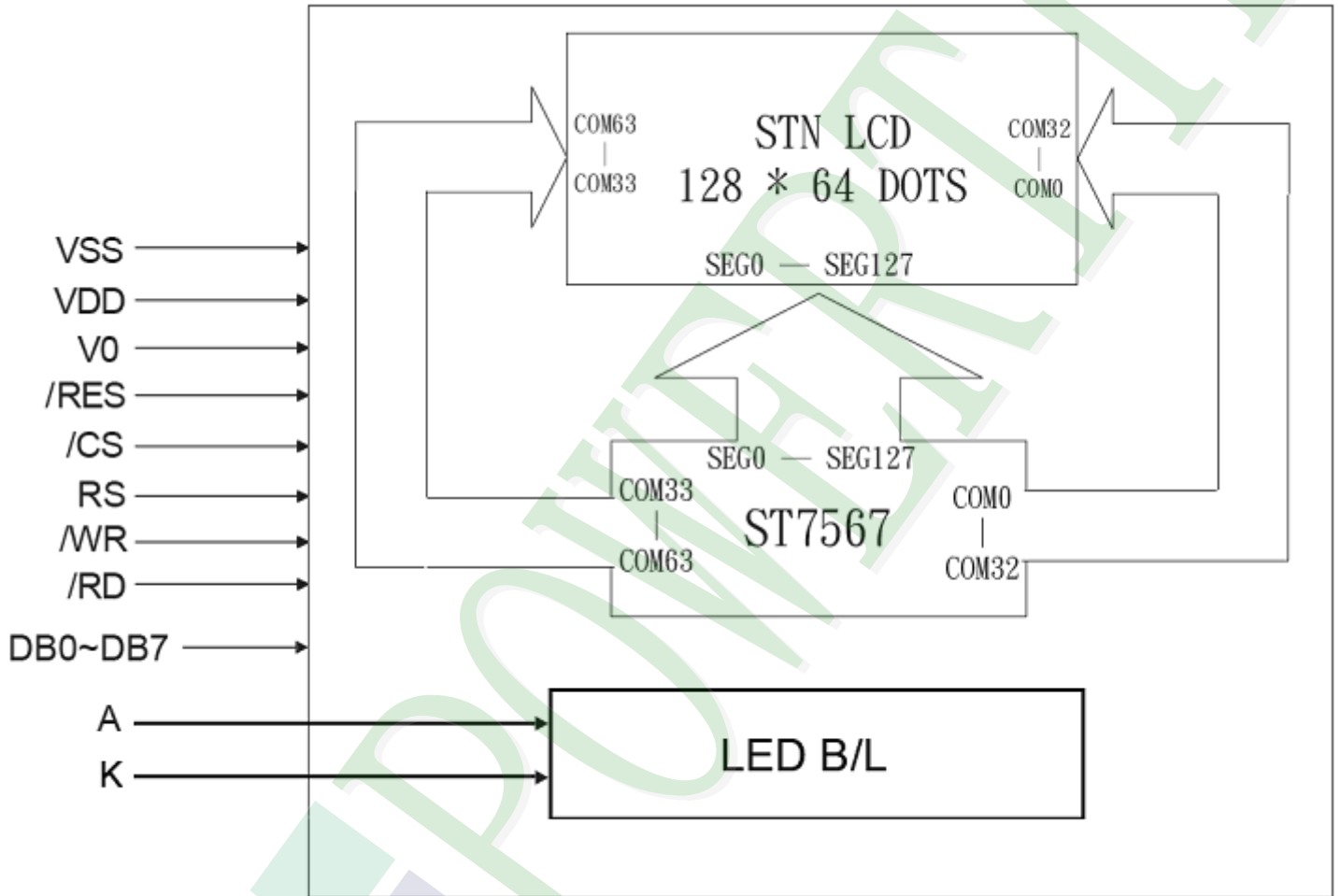

2.2 Interface Pin Description

Pin No.	Symbol	Function
1	VSS	Power Supply (VSS=0)
2	VDD	Power Supply (VDD>VSS)
3	V0	NO Connection
4	/RES	Controller reset (module reset)
5	/CS	Used to enter chip select signal
6	RS	Select control data or display data for read/write operation “L”=control data “H”=display data
7	/WR	Write signal input pin , active “L”.
8	/RD	Read signal input pin , active “L”
9	DB0	Data bus bit 0.
10	DB1	Data bus bit 1.
11	DB2	Data bus bit 2.
12	DB3	Data bus bit 3.
13	DB4	Data bus bit 4.
14	DB5	Data bus bit 5.
15	DB6	Data bus bit 6.
16	DB7	Data bus bit 7.
17	A	Power supply LED backlight(+)
18	K	Power supply LED backlight(-)

2.3 Timing Characteristics

System Bus Timing for 8080 Series MPU

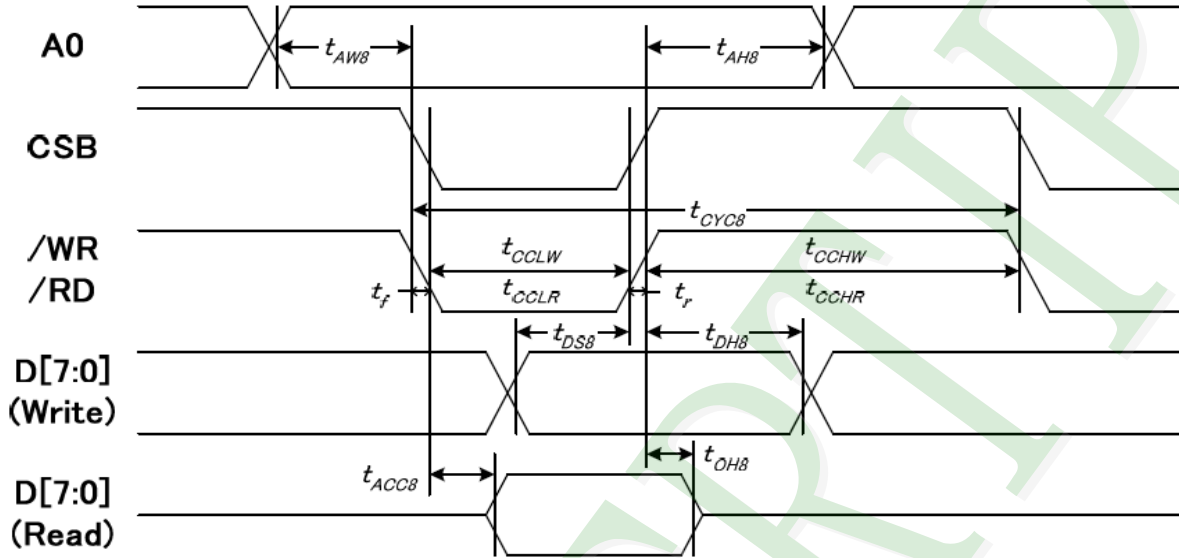

(VDD = 3.3V, Ta = -30~85°C)

Item	Signal	Symbol	Condition	Min.	Max.	Unit
Address setup time	A0	tAW8		0	—	ns
Address hold time		tAH8		10	—	
System cycle time	/WR	tCYC8		240	—	
Enable L pulse width (WRITE)		tCCLW		80	—	
Enable H pulse width (WRITE)		tCCHW		80	—	
Enable L pulse width (READ)		RD	tCCLR		140	
Enable H pulse width (READ)	tCCHR			80	—	
WRITE Data setup time	D[7:0]	tDS8		40	—	
WRITE Data hold time		tDH8		20	—	
READ access time	D[7:0]	tACC8	CL = 16 pF	—	70	
READ Output disable time		tOH8	CL = 16 pF	5	50	

(VDD = 2.8V, Ta = -30~85°C)

Item	Signal	Symbol	Condition	Min.	Max.	Unit
Address setup time	A0	tAW8		0	—	ns
Address hold time		tAH8		0	—	
System cycle time	/WR	tCYC8		400	—	
Enable L pulse width (WRITE)		tCCLW		220	—	
Enable H pulse width (WRITE)		tCCHW		180	—	
Enable L pulse width (READ)		RD	tCCLR		220	
Enable H pulse width (READ)	tCCHR			180	—	
WRITE Data setup time	D[7:0]	tDS8		40	—	
WRITE Data hold time		tDH8		20	—	
READ access time	D[7:0]	tACC8	CL = 16 pF	—	140	
READ Output disable time		tOH8	CL = 16 pF	10	100	

(VDD = 1.8V , Ta = -30~85°C)

Item	Signal	Symbol	Condition	Min.	Max.	Unit
Address setup time	A0	tAW8		0	—	ns
Address hold time		tAH8		0	—	
System cycle time	/WR	tCYC8		640	—	
Enable L pulse width (WRITE)		tCCLW		360	—	
Enable H pulse width (WRITE)		tCCHW		280	—	
Enable L pulse width (READ)	RD	tCCLR		360	—	
Enable H pulse width (READ)		tCCHR		280	—	
WRITE Data setup time	D[7:0]	tDS8		80	—	
WRITE Data hold time		tDH8		20	—	
READ access time		tACC8	CL = 16 pF	—	240	
READ Output disable time		tOH8	CL = 16 pF	10	200	

*1 The input signal rise time and fall time (t_r , t_f) is specified at 15 ns or less. When the system cycle time is extremely fast, $(t_r + t_f) \leq (t_{CYC8} - t_{CCLW} - t_{CCHW})$ for $(t_r + t_f) \leq (t_{CYC8} - t_{CCLR} - t_{CCHR})$ are specified.

*2 All timing is specified using 20% and 80% of VDD1 as the reference.

*3 tCCLW and tCCLR are specified as the overlap between CSB being "L" and WR and RD being at the "L" level.

Hardware Reset Timing

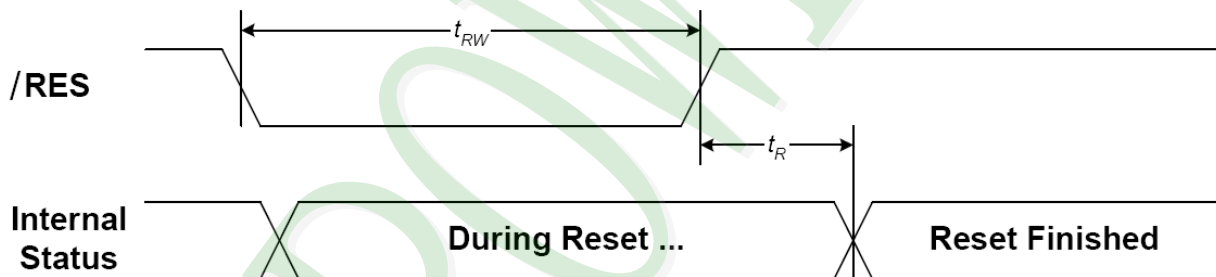

(VDD = 3.3V , Ta = -30~85°C)

Item	Symbol	Condition	Min.	Max.	Unit
Reset time	tR		—	1.0	us
Reset "L" pulse width	tRW		1.0	—	

(VDD = 2.8V , Ta = -30~85°C)

Item	Symbol	Condition	Min.	Max.	Unit
Reset time	tR		—	2.0	us
Reset "L" pulse width	tRW		2.0	—	

2.4 Display command

INSTRUCTION	A0	R/W (RWR)	COMMAND BYTE								DESCRIPTION
			D7	D6	D5	D4	D3	D2	D1	D0	
(1) Display ON/OFF	0	0	1	0	1	0	1	1	1	D	D=1, display ON D=0, display OFF
(2) Set Start Line	0	0	0	1	S5	S4	S3	S2	S1	S0	Set display start line
(3) Set Page Address	0	0	1	0	1	1	Y3	Y2	Y1	Y0	Set page address
(4) Set Column Address	0	0	0	0	0	1	X7	X6	X5	X4	Set column address (MSB)
	0	0	0	0	0	0	X3	X2	X1	X0	Set column address (LSB)
(5) Read Status	0	1	0	MX	D	RST	0	0	0	0	Read IC Status
(6) Write Data	1	0	D7	D6	D5	D4	D3	D2	D1	D0	Write display data to RAM
(7) Read Data	1	1	D7	D6	D5	D4	D3	D2	D1	D0	Read display data from RAM
(8) SEG Direction	0	0	1	0	1	0	0	0	0	MX	Set scan direction of SEG MX=1, reverse direction MX=0, normal direction
(9) Inverse Display	0	0	1	0	1	0	0	1	1	INV	INV =1, inverse display INV =0, normal display
(10) All Pixel ON	0	0	1	0	1	0	0	1	0	AP	AP=1, set all pixel ON AP=0, normal display
(11) Bias Select	0	0	1	0	1	0	0	0	1	BS	Select bias setting 0=1/9; 1=1/7 (at 1/65 duty)
(12) Read-modify-Write	0	0	1	1	1	0	0	0	0	0	Column address increment: Read:+0, Write:+1
(13) END	0	0	1	1	1	0	1	1	1	0	Exit Read-modify-Write mode
(14) RESET	0	0	1	1	1	0	0	0	1	0	Software reset
(15) COM Direction	0	0	1	1	0	0	MY	-	-	-	Set output direction of COM MY=1, reverse direction MY=0, normal direction
(16) Power Control	0	0	0	0	1	0	1	VB	VR	VF	Control built-in power circuit ON/OFF
(17) Regulation Ratio	0	0	0	0	1	0	0	RR2	RR1	RR0	Select regulation resistor ratio
(18) Set EV	0	0	1	0	0	0	0	0	0	1	Double command!! Set electronic volume (EV) level
	0	0	0	0	EV5	EV4	EV3	EV2	EV1	EV0	
(19) Set Booster	0	0	1	1	1	1	1	0	0	0	Double command!! Set booster level: 00=4X, 01=5X, 10=6X
	0	0	0	0	0	0	0	0	BL1	BL0	
(20) Power Save	0	0	Compound Command								Display OFF + All Pixel ON
(21) NOP	0	0	1	1	1	0	0	0	1	1	No operation
(22) Test	0	0	1	1	1	1	1	1	1	-	Do NOT use. Reserved for testing.

Note: Symbol “-” means this bit can be “H” or “L”.

2.5 Jumper

8080 MPU I/F:

J1(2.3)/J2(1.3)/J3(2.3)/J6 : SHORT;

OTHER : OPEN

3. QUALITY ASSURANCE SYSTEM

3.1 Quality Assurance Flow Chart

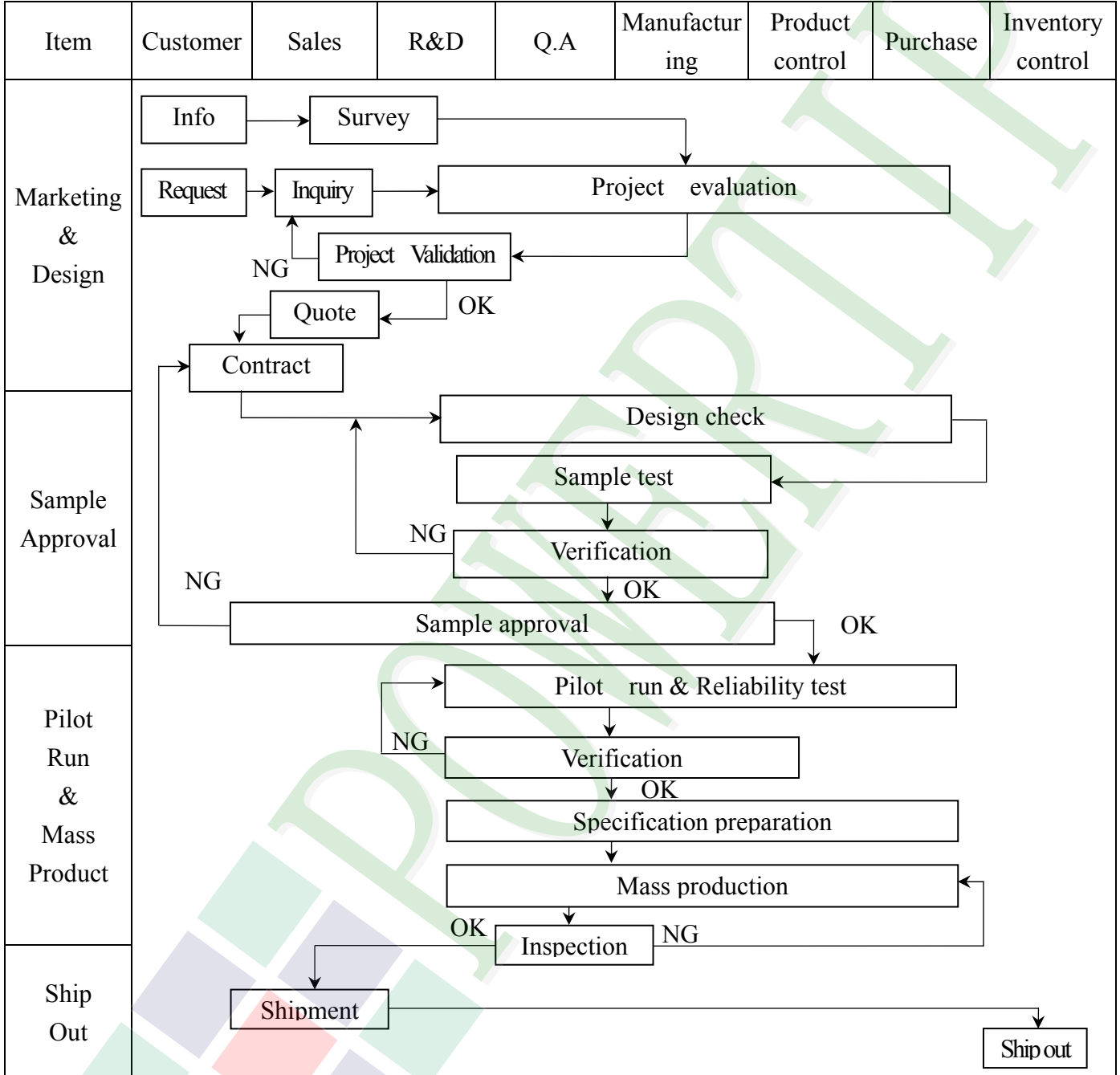

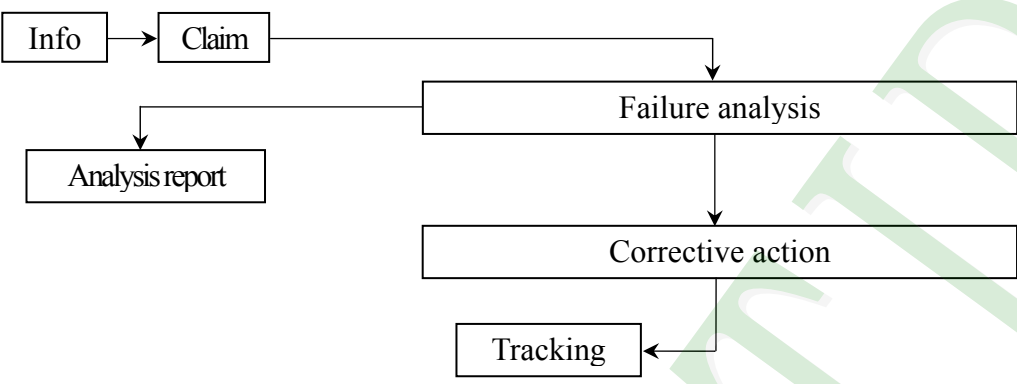
Item	Customer	Sales	R&D	Q.A	Manufacturing	Product control	Purchase	Inventory control
Sales Service	 <pre> graph TD Info[Info] --> Claim[Claim] Claim --> Failure[Failure analysis] Claim --> Report[Analysis report] Failure --> Action[Corrective action] Action --> Tracking[Tracking] </pre>							
Q.A Activity	1. ISO 9001 Maintenance Activities 3. Equipment calibration 5. Standardization Management				2. Process improvement proposal 4. Education And Training Activities			

3.2. Inspection Specification

◆ Scope : The document shall be applied to LCD Module for Monotype and Color STN(Ver. B01).

◆ Inspection Standard : MIL-STD-105E Table Normal Inspection Single Sampling Level II .

◆ Equipment : Gauge 、 MIL-STD 、 Powertip Tester 、 Sample

◆ Defect Level : Major Defect AQL : 0.4 ; Minor Defect : AQL : 1.5 .

◆ OUT Going Defect Level : Sampling .

◆ Manner of appearance test :

- (1). The test be under 20W×2 fluorescent light ' and distance of view must be at 30 cm.
- (2). Standard of inspection : (Unit : mm)
- (3). The test direction is base on about around 45° of vertical line. (Fig. 1)
- (4). Definition of area . (Fig. 2)

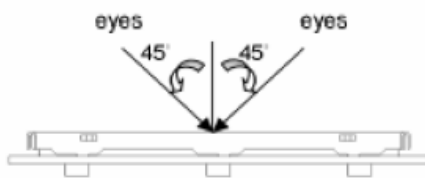

Fig.1

B area : Outside of viewing area



Fig. 2

A area : viewing area

◆ Specification:

NO	Item	Criterion	Level
01	Product condition	1. 1 The part number is inconsistent with work order of Production.	Major
		1. 2 Mixed production types.	Major
		1. 3 Assembled in inverse direction.	Major
02	Quantity	2. 1 The quantity is inconsistent with work order of production.	Major
03	Outline dimension	3. 1 Product dimension and structure must conform to Structure diagram.	Major
04	Electrical Testing	4. 1 Missing line character and icon.	Major
		4. 2 No function or no display.	Major
		4. 3 Output data is error.	Major
		4. 4 LCD viewing angle defect.	Major
		4. 5 Current consumption exceeds product specifications.	Major

◆ Specification For Monotype and Color STN :

(Ver. B01)

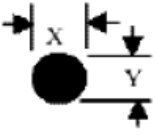
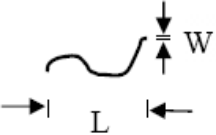
NO	Item	Criterion	Level																																					
05	<p>Black or white dot、scratch、contamination</p> <p>Round type</p>  <p>$\Phi = (x+y)/2$</p> <p>Line type</p> 	<p>5. 1 Round type:</p> <p>5. 1. 1 display only :</p> <ul style="list-style-type: none"> • White and black spots on display ≤ 0.30 mm , no more than 4 white or black spots present. • Densely spaced : NO more than two spots or lines within 3 mm. <p>5. 1. 2 Non-display :</p> <table border="1"> <thead> <tr> <th rowspan="2">Dimension (diameter : Φ)</th> <th colspan="2">Acceptance (Q'ty)</th> </tr> <tr> <th>A area</th> <th>B area</th> </tr> </thead> <tbody> <tr> <td>$\Phi \leq 0.10$</td> <td colspan="2">Accept no dense</td> </tr> <tr> <td>$0.10 < \Phi \leq 0.20$</td> <td>3</td> <td rowspan="2">Ignore</td> </tr> <tr> <td>$0.20 < \Phi \leq 0.30$</td> <td>2</td> </tr> <tr> <td>Total quantity</td> <td colspan="2">4</td> </tr> </tbody> </table> <p>5. 1. 3 Line type:</p> <table border="1"> <thead> <tr> <th colspan="2">Dimension</th> <th colspan="2">Acceptance (Q'ty)</th> </tr> <tr> <th>Length (L)</th> <th>Width (W)</th> <th>A area</th> <th>B area</th> </tr> </thead> <tbody> <tr> <td>---</td> <td>$W \leq 0.03$</td> <td>Accept no dense</td> <td rowspan="3">Ignore</td> </tr> <tr> <td>$L \leq 3.0$</td> <td>$0.03 < W \leq 0.05$</td> <td rowspan="2">4</td> </tr> <tr> <td>$L \leq 2.5$</td> <td>$0.05 < W \leq 0.075$</td> </tr> <tr> <td>---</td> <td>$W > 0.075$</td> <td colspan="2">As round type</td> </tr> </tbody> </table>	Dimension (diameter : Φ)	Acceptance (Q'ty)		A area	B area	$\Phi \leq 0.10$	Accept no dense		$0.10 < \Phi \leq 0.20$	3	Ignore	$0.20 < \Phi \leq 0.30$	2	Total quantity	4		Dimension		Acceptance (Q'ty)		Length (L)	Width (W)	A area	B area	---	$W \leq 0.03$	Accept no dense	Ignore	$L \leq 3.0$	$0.03 < W \leq 0.05$	4	$L \leq 2.5$	$0.05 < W \leq 0.075$	---	$W > 0.075$	As round type		Minor
Dimension (diameter : Φ)	Acceptance (Q'ty)																																							
	A area	B area																																						
$\Phi \leq 0.10$	Accept no dense																																							
$0.10 < \Phi \leq 0.20$	3	Ignore																																						
$0.20 < \Phi \leq 0.30$	2																																							
Total quantity	4																																							
Dimension		Acceptance (Q'ty)																																						
Length (L)	Width (W)	A area	B area																																					
---	$W \leq 0.03$	Accept no dense	Ignore																																					
$L \leq 3.0$	$0.03 < W \leq 0.05$	4																																						
$L \leq 2.5$	$0.05 < W \leq 0.075$																																							
---	$W > 0.075$	As round type																																						
06	<p>Polarizer Bubble</p>	<table border="1"> <thead> <tr> <th rowspan="2">Dimension (diameter : Φ)</th> <th colspan="2">Acceptance (Q'ty)</th> </tr> <tr> <th>A area</th> <th>B area</th> </tr> </thead> <tbody> <tr> <td>$\Phi \leq 0.20$</td> <td colspan="2">Accept no dense</td> </tr> <tr> <td>$0.20 < \Phi \leq 0.50$</td> <td>3</td> <td rowspan="3">Ignore</td> </tr> <tr> <td>$0.50 < \Phi \leq 1.00$</td> <td>2</td> </tr> <tr> <td>$\Phi > 1.00$</td> <td>0</td> </tr> <tr> <td>Total quantity</td> <td colspan="2">4</td> </tr> </tbody> </table>	Dimension (diameter : Φ)	Acceptance (Q'ty)		A area	B area	$\Phi \leq 0.20$	Accept no dense		$0.20 < \Phi \leq 0.50$	3	Ignore	$0.50 < \Phi \leq 1.00$	2	$\Phi > 1.00$	0	Total quantity	4		Minor																			
Dimension (diameter : Φ)	Acceptance (Q'ty)																																							
	A area	B area																																						
$\Phi \leq 0.20$	Accept no dense																																							
$0.20 < \Phi \leq 0.50$	3	Ignore																																						
$0.50 < \Phi \leq 1.00$	2																																							
$\Phi > 1.00$	0																																							
Total quantity	4																																							

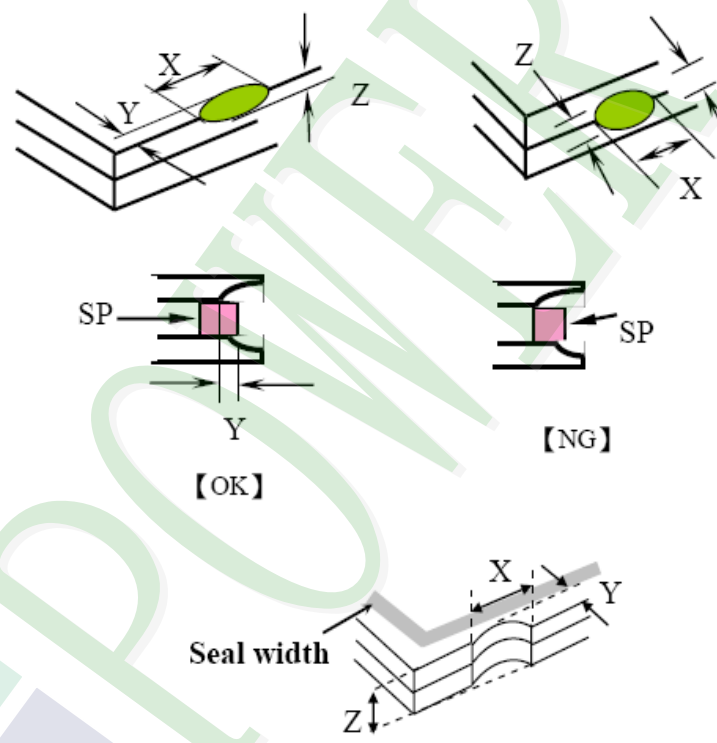
NO	Item	Criterion	Level									
07	The crack of glass	<p>Symbols :</p> <p>X : The length of crack Z : The thickness of crack t : The thickness of glass</p> <p>Y : The width of crack. W : terminal length a : LCD side length</p> <hr/> <p>7.1 General glass chip : 7.1.1 Chip on panel surface and crack between panels:</p>  <table border="1" data-bbox="502 1601 1300 1915"> <thead> <tr> <th>X</th> <th>Y</th> <th>Z</th> </tr> </thead> <tbody> <tr> <td>$\leq a$</td> <td>Crack can't enter viewing area</td> <td>$\leq 1/2 t$</td> </tr> <tr> <td>$\leq a$</td> <td>Crack can't exceed the half of SP width.</td> <td>$1/2 t < Z \leq 2 t$</td> </tr> </tbody> </table>	X	Y	Z	$\leq a$	Crack can't enter viewing area	$\leq 1/2 t$	$\leq a$	Crack can't exceed the half of SP width.	$1/2 t < Z \leq 2 t$	Minor
		X	Y	Z								
$\leq a$	Crack can't enter viewing area	$\leq 1/2 t$										
$\leq a$	Crack can't exceed the half of SP width.	$1/2 t < Z \leq 2 t$										

◆ Specification For Monotype and Color STN :

(Ver. B01)

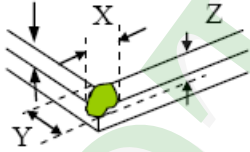
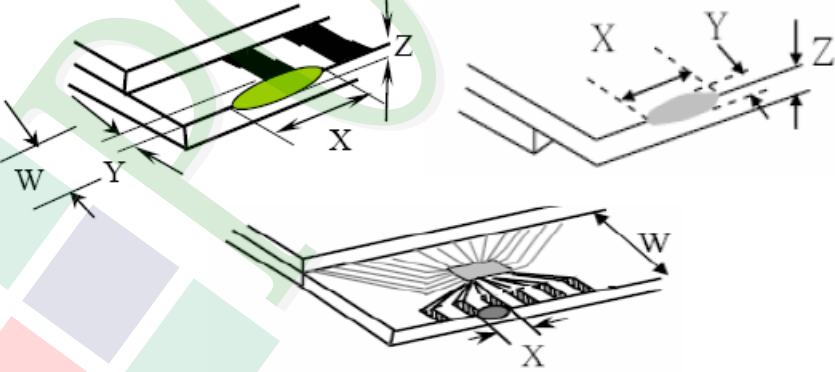
NO	Item	Criterion	Level										
07	The crack of glass	<p>Symbols :</p> <p>X : The length of crack Z : The thickness of crack t : The thickness of glass</p> <p>Y : The width of crack. W : terminal length a : LCD side length</p> <hr/> <p>7.1.2 Corner crack :</p>  <table border="1" data-bbox="501 833 1316 1124"> <thead> <tr> <th>X</th> <th>Y</th> <th>Z</th> </tr> </thead> <tbody> <tr> <td>$\leq 1/5 a$</td> <td>Crack can't enter viewing area</td> <td>$Z \leq 1/2 t$</td> </tr> <tr> <td>$\leq 1/5 a$</td> <td>Crack can't exceed the half of SP width.</td> <td>$1/2 t < Z \leq 2 t$</td> </tr> </tbody> </table>	X	Y	Z	$\leq 1/5 a$	Crack can't enter viewing area	$Z \leq 1/2 t$	$\leq 1/5 a$	Crack can't exceed the half of SP width.	$1/2 t < Z \leq 2 t$	Minor	
		X	Y	Z									
$\leq 1/5 a$	Crack can't enter viewing area	$Z \leq 1/2 t$											
$\leq 1/5 a$	Crack can't exceed the half of SP width.	$1/2 t < Z \leq 2 t$											
<p>7.2 Protrusion over terminal :</p> <p>7.2.1 Chip on electrode pad :</p>  <table border="1" data-bbox="466 1706 1254 1881"> <thead> <tr> <th></th> <th>X</th> <th>Y</th> <th>Z</th> </tr> </thead> <tbody> <tr> <td>Front</td> <td>$\leq a$</td> <td>$\leq 1/2 W$</td> <td>$\leq t$</td> </tr> <tr> <td>Back</td> <td colspan="3">Neglect</td> </tr> </tbody> </table>		X	Y	Z	Front	$\leq a$	$\leq 1/2 W$	$\leq t$	Back	Neglect			
	X	Y	Z										
Front	$\leq a$	$\leq 1/2 W$	$\leq t$										
Back	Neglect												

◆ Specification For Monotype and Color STN :

(Ver. B01)

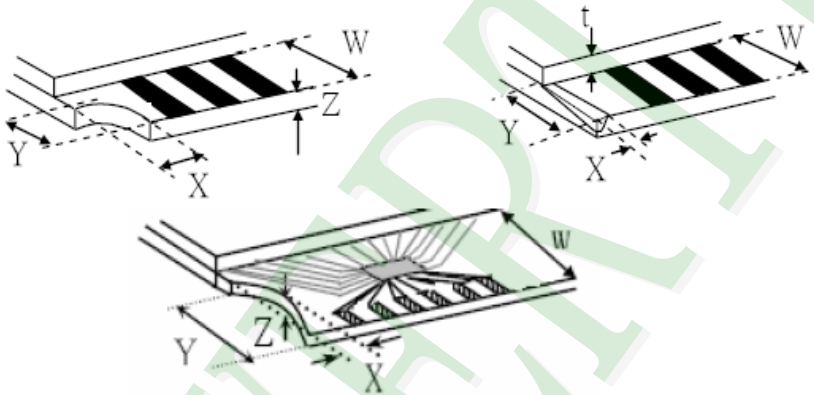
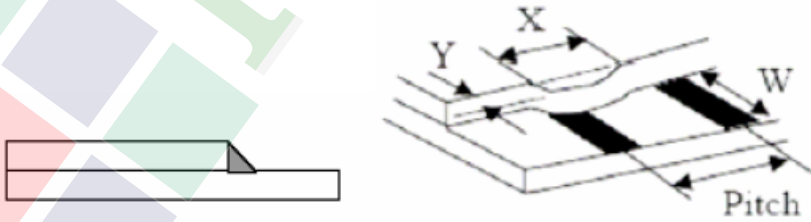
NO	Item	Criterion	Level									
07	The crack of glass	<p>Symbols :</p> <p>X : The length of crack Y : The width of crack. Z : The thickness of crack W : terminal length t : The thickness of glass a : LCD side length</p>	Minor									
		<p>7.2.2 Non-conductive portion :</p>  <table border="1" data-bbox="580 1106 1206 1265"> <thead> <tr> <th>X</th> <th>Y</th> <th>Z</th> </tr> </thead> <tbody> <tr> <td>$\leq 1/3 a$</td> <td>$\leq W$</td> <td>$\leq t$</td> </tr> </tbody> </table> <p>⊙ If the chipped area touches the ITO terminal, over 2/3 of the ITO must remain and be inspected according to electrode terminal specifications.</p> <p>7.2.3 Glass remain :</p>  <table border="1" data-bbox="501 1816 1189 1964"> <thead> <tr> <th>X</th> <th>Y</th> <th>Z</th> </tr> </thead> <tbody> <tr> <td>$\leq a$</td> <td>$\leq 1/3 W$</td> <td>$\leq t$</td> </tr> </tbody> </table>		X	Y	Z	$\leq 1/3 a$	$\leq W$	$\leq t$	X	Y	Z
X	Y	Z										
$\leq 1/3 a$	$\leq W$	$\leq t$										
X	Y	Z										
$\leq a$	$\leq 1/3 W$	$\leq t$										



◆ Specification For Monotype and Color STN :

(Ver. B01)

NO	Item	Criterion	Level
08	Backlight elements	8. 1 Backlight can't work normally.	Major
		8. 2 Backlight doesn't light or color is wrong.	Major
		8. 3 Illumination source flickers when lit.	Major
09	General appearance	9. 1 Pin type must match type in specification sheet.	Major
		9. 2 No short circuits in components on PCB or FPC.	Major
		9. 3 Product packaging must the same as specified on packaging specification sheet.	Minor
		9. 4 The folding and peeled off in polarizer are not acceptable.	Minor
		9. 5 The PCB or FPC between B/L assembled distance (PCB or FPC) is ≤ 1.5 mm.	Minor

5. PRECAUTION RELATING PRODUCT HANDLING

5.1 SAFETY

- 5.1.1 If the LCD panel breaks , be careful not to get the liquid crystal to touch your skin.
- 5.1.2 If the liquid crystal touches your skin or clothes , please wash it off immediately by using soap and water.

5.2 HANDLING

- 5.2.1 Avoid any strong mechanical shock which can break the glass.
- 5.2.2 Avoid static electricity which can damage the CMOS LSI—When working with the module , be sure to ground your body and any electrical equipment you may be using.
- 5.2.3 Do not remove the panel or frame from the module.
- 5.2.4 The polarizing plate of the display is very fragile. So , please handle it very carefully ,do not touch , push or rub the exposed polarizing with anything harder than an HB pencil lead (glass , tweezers , etc.)
- 5.2.5 Do not wipe the polarizing plate with a dry cloth , as it may easily scratch the surface of plate.
- 5.2.6 Do not touch the display area with bare hands , this will stain the display area.
- 5.2.7 Do not use ketonics solvent & aromatic solvent. Use with a soft cloth soaked with a cleaning naphtha solvent.
- 5.2.8 To control temperature and time of soldering is $320\pm 10^{\circ}\text{C}$ and 3-5 sec.
- 5.2.9 To avoid liquid (include organic solvent) stained on LCM .

5.3 STORAGE

- 5.3.1 Store the panel or module in a dark place where the temperature is $25^{\circ}\text{C} \pm 5^{\circ}\text{C}$ and the humidity is below 65% RH.
- 5.3.2 Do not place the module near organics solvents or corrosive gases.
- 5.3.3 Do not crush , shake , or jolt the module.

5.4 TERMS OF WARRANTY

- 5.4.1 Applicable warrant period
The period is within thirteen months since the date of shipping out under normal using and storage conditions.
- 5.4.2 Unaccepted responsibility
This product has been manufactured to your company's specification as a part for use in your company's general electronic products. It is guaranteed to perform according to delivery specifications. For any other use apart from general electronic equipment , we cannot take responsibility if the product is used in nuclear power control equipment , aerospace equipment , fire and security systems or any other applications in which there is a direct risk to human life and where extremely high levels of reliability are required.

Ver.001

LCM包裝規格書

LCM Packaging Specifications

Approve

Check

Contact

Ryan

Zhouaimei

Terry

Documents NO.

JPKG-PE12864WRF-042HL4Q

1. 包裝材料規格表 (Packaging Material) : (per carton)

No.	Item	Model	Dimensions (mm)	1Pcs Weight	Quantity	Total Weight
1	成品 LCM	PE12864WRF-042HL4Q	80.0*54.0*9.7	0.03	288	8.64
2	靜電袋 (1)BAG	BAG150100ARABA	150*120*0.05	0.002	288	0.576
3	氣泡袋(2)BAG	BAG100080BWABA	100*80	0.0015	288	0.432
4	氣泡墊(3)BAG	BAG290240BRBBA	240*290*5	0.0029	16	0.0464
5	刀卡A2(4)BX	BX29500072BZBA	295*72*3	0.011	104	1.144
6	刀卡B2(5)BX	BX24500072BZBA	245*72*3	0.01	32	0.32
7	C2內盒(6)Product Box	BX31025580AABA	310*255*86	0.221	8	1.768
8	外紙箱(7)Carton	BX52532536CCBA	525*325*360	1.092	1	1.092
9						

2. 一整箱總重量 (Total LCD Weight in carton) : 14.02 Kg±10%

3. 單箱數量規格表 (Packaging Specifications and Quantity) :

(1)LCM quantity per box : no. per box	12	x no. of box	3	=	36
(2)Total LCM quantity in carton : quantity per box	36	x no. of boxes	8	=	288

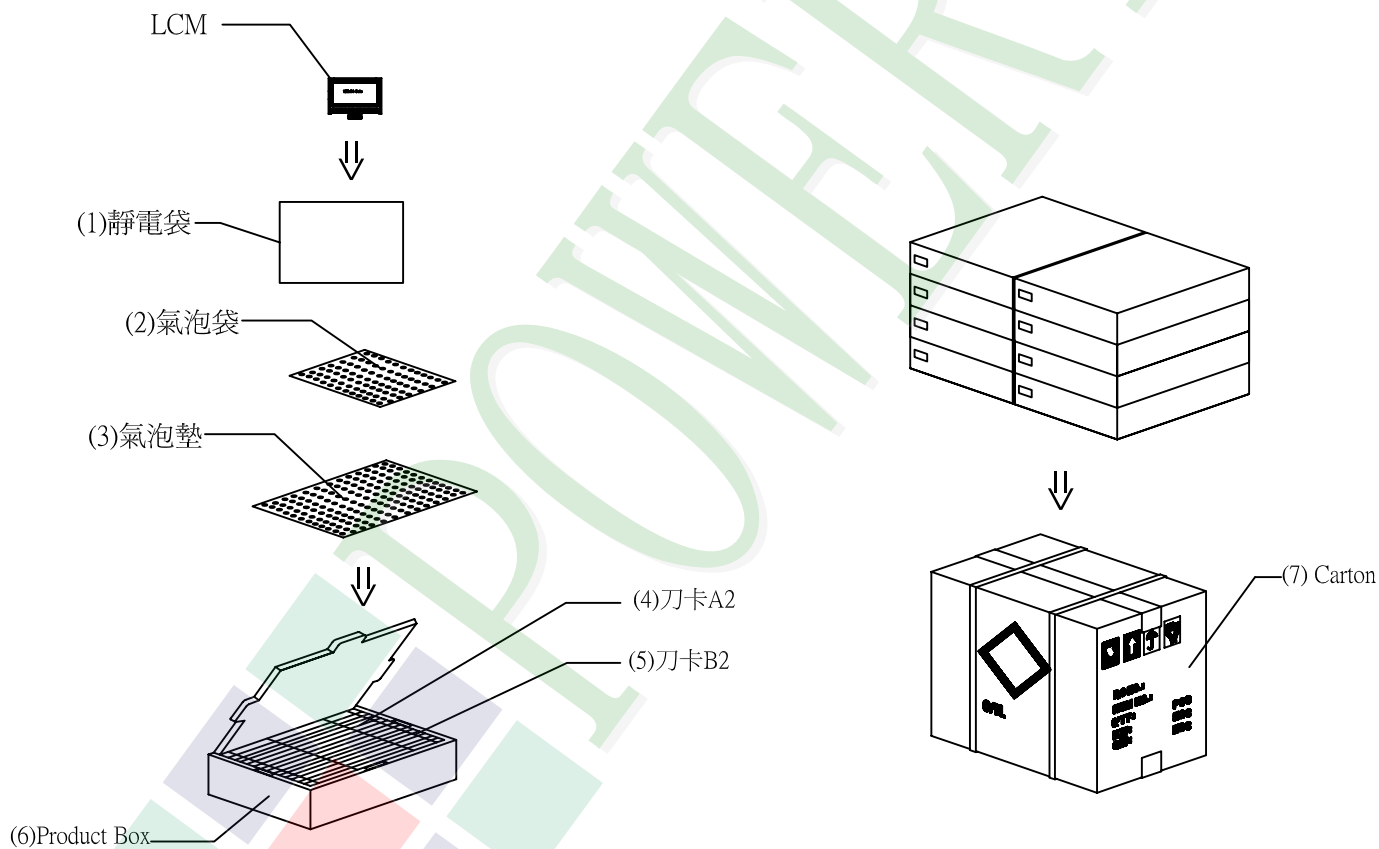

特 記 事 項 (REMARK)

1. Label Specifications :

MODEL:
LOT NO:
QUANTITY:
CHECK:

前后空一格