

SPECIFICATIONS

CUSTOMER	:	CCN026
SAMPLE CODE	:	SE12864WRF-055-H-Q
MASS PRODUCTION CODE	:	PE12864WRF-055-H-Q
SAMPLE VERSION	:	03
SPECIFICATIONS EDITION	:	005
DRAWING NO. (Ver.)	:	LMD-PE12864WRF-055-H-Q_001
PACKAGING NO. (Ver.)	:	JPKG-PE12864WRF-055-H-Q_002

Customer Approved

Date:



Approved	Checked	Designer
閔偉	張久慧	劉進

- Preliminary specification for design input
- Specification for sample approval

POWER TIP TECH. CORP.

Headquarters: No.8, 6 th Road, Taichung Industrial Park, Taichung, Taiwan 台中市 407 工業區六路 8 號	TEL: 886-4-2355-8168 FAX: 886-4-2355-8166	E-mail: sales@powertip.com.tw Http://www.powertip.com.tw
--	--	---

Contents

1. SPECIFICATIONS

- 1.1 Features**
- 1.2 Mechanical Specifications**
- 1.3 Absolute Maximum Ratings**
- 1.4 DC Electrical Characteristics**
- 1.5 Optical Characteristics**
- 1.6 Backlight Characteristics**

2. MODULE STRUCTURE

- 2.1 Counter Drawing**
- 2.2 Interface Pin Description**
- 2.3 Timing Characteristics**

3. QUALITY ASSURANCE SYSTEM

- 3.1 Quality Assurance Flow Chart**
- 3.2 Inspection Specification**

4. RELIABILITY TEST

- 4.1 Reliability Test Condition**

5. PRECAUTION RELATING PRODUCT HANDLING

- 5.1 Safety**
- 5.2 Handling**
- 5.3 Storage**
- 5.4 Terms of Warranty**

Appendix :

- 1. LCM drawing**
- 2. LCM Packaging Specifications**

Note : For detailed information please refer to IC data sheet : Sitronix ST7567-G4

1. SPECIFICATIONS

1.1 Features

Item	Standard Value
Display Type	128 * 64 Dots
LCD Type	FSTN, Positive, Transflective
Driver Condition	LCD Module : 1/65 Duty, 1/9 Bias
Viewing Direction	6 O'clock
Backlight Type	LED (White)
Weight	11 g
Interface	Support 8 bits Parallel interface for 8080 or 6800 series MPU & Serial (4-Line SPI) interface
Controller / Driver IC	Sitronix ST7567-G4
ROHS	THIS PRODUCT CONFORMS THE ROHS OF PTC Detail information please refer web side : http://www.powertip.com.tw/news.php?area_id_view=1085560481/

1.2 Mechanical Specifications

Item	Standard Value	Unit
Outline Dimension	55.2 (W) * 39.8 (L) * 5.0 (H)	mm
Viewing Area	45.2 (W) * 27.0 (L)	mm
Active Area	40.95 (W) * 24.31 (L)	mm
Dot Size	0.31 (W) * 0.37 (H)	mm
Dot Pitch	0.32 (W) * 0.38 (H)	mm

Note : For detailed information please refer to LCM drawing

1.3 Absolute Maximum Ratings

Item	Symbol	Condition	Min.	Max.	Unit
Power Supply Voltage	VDD	-	-0.3	+3.6	V
LCD Power Supply Voltage	VLCD	V0-XV0	-0.3	+16	V
LCD Power Driving Voltage	VG, VM	-	-0.3	VDD	V
Operating Temperature	T _{OP}	-	-20	+70	°C
Storage Temperature	T _{ST}	-	-30	+80	°C
Storage Humidity	H _D	Ta < 40 °C	20	90	%RH

1.4 DC Electrical Characteristics

VDD = 3.0V, VSS = 0V, Ta = 25°C

Item	Symbol	Condition	Min.	Typ.	Max.	Unit
Logic Supply Voltage	VDD	-	2.7	3.0	3.3	V
“H” Input Voltage	V _{IH}	-	0.7*VDD	-	VDD	V
“L” Input Voltage	V _{IL}	-	VSS	-	0.3*VDD	V
“H” Output Voltage	V _{OH}	IOUT=1mA, VDD=3.0V	0.8*VDD	-	VDD	V
“L” Output Voltage	V _{OL}	IOUT=-1mA, VDD=3.0V	VSS	-	0.2*VDD	V
Supply Current	IDD	VDD= 3.0V; V _{OP} = 9.8V; Pattern= Full display	-	0.3	-	mA
		VDD= 3.0V; V _{OP} = 9.8V; Pattern= Horizontal line *1	-	0.4	0.6	
LCM Driver Voltage	V _{op} *2	-20°C	9.7	10.0	10.3	V
		+25°C	9.5	9.8	10.1	
		+70°C	8.6	8.9	9.2	

Note : *1. The Maximum current display.

*2. The V_{OP} test point is V0 – XV0.

*3. Initial code

```

MOV      A,#10101110B      ;Display OFF
CALL     WIR
MOV      A,#10100010B      ;Set 1/9 Bias
CALL     WIR
MOV      A,#10100000B      ;SEG DIRECTION
CALL     WIR
MOV      A,#11001000B      ;COM DIRECTION
CALL     WIR
MOV      A,#10100110B      ;INVERSE DISPLAY(NORMAL DISPLAY)
CALL     WIR
MOV      A,#10100100B      ;ALL PIXEL ON(NORMAL DISPLAY)
CALL     WIR
MOV      A,#01000000B      ;SET START LINE (SEG 0)
CALL     WIR
MOV      A,#00100101B      ;Regulation Ratio(RR=5.5)
CALL     WIR
MOV      A,#10000001B      ;Set EV (V0 = RR X [ ( 99 + EV ) / 162 ] X 2.1)
CALL     WIR
MOV      A,#00101000B      ;40
CALL     WIR
MOV      A,#00101100B      ;Set Power Control
CALL     WIR
NOP
MOV      A,#00101110B      ;Set Power Control
CALL     WIR
NOP
MOV      A,#00101111B      ;Set Power Control
CALL     WIR
NOP
MOV      A,#11111000B      ;SET Booster
CALL     WIR
MOV      A,#00000000B      ;Booster 4X
CALL     WIR
MOV      A,#10101111B      ;Display ON
CALL     WIR

```

1.5 Optical Characteristics

LCD Panel: 1/65 Duty, 1/9 Bias, VLCD = 9.8V, Ta = 25°C

Item	Symbol	Conditions	Min.	Typ.	Max.	Unit	Reference
Response Time	Rise	tr	-	85	128	ms	Note 2
	Fall	tf	-	215	323		
Viewing angle range	Top	$\Theta Y+$	-	40	-	-	Notes 1
	Bottom	$\Theta Y-$	-	40	-		
	Left	$\Theta X-$	-	40	-		
	Right	$\Theta X+$	-	40	-		
Contrast Ratio	CR	$\theta = 0^\circ$, $\varnothing = 270^\circ$	-	5	-	-	Note 3
Average Brightness (With B/L)	IV	IF=80mA	35	50	-	cd/m ²	-
CIE Color Coordinate (With B/L)	X		0.23	0.28	0.33	-	Note 4
	Y		0.25	0.30	0.35	-	
Uniformity	ΔB	-	70	-	-	%	

Note 4:

1 : $\Delta B = B(\min) / B(\max) * 100\%$

2 : Measurement Condition for Optical Characteristics:

a : Environment: $25^\circ\text{C} \pm 5^\circ\text{C}$ / $60 \pm 20\%$ R.H , no wind , dark room below 10 Lux at typical lamp current and typical operating frequency.

b : Measurement Distance: 500 ± 50 mm , ($\theta = 0^\circ$)

c : Equipment: TOPCON BM-7 fast , (field 0.2°) , after 10 minutes operation.

d : The uncertainty of the C.I.E coordinate measurement ± 0.01 , Average Brightness $\pm 4\%$

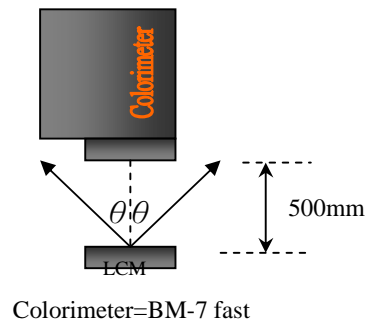
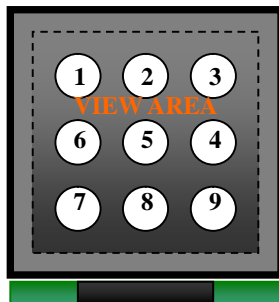

Note 1.

Optical characteristics-2

Viewing angle

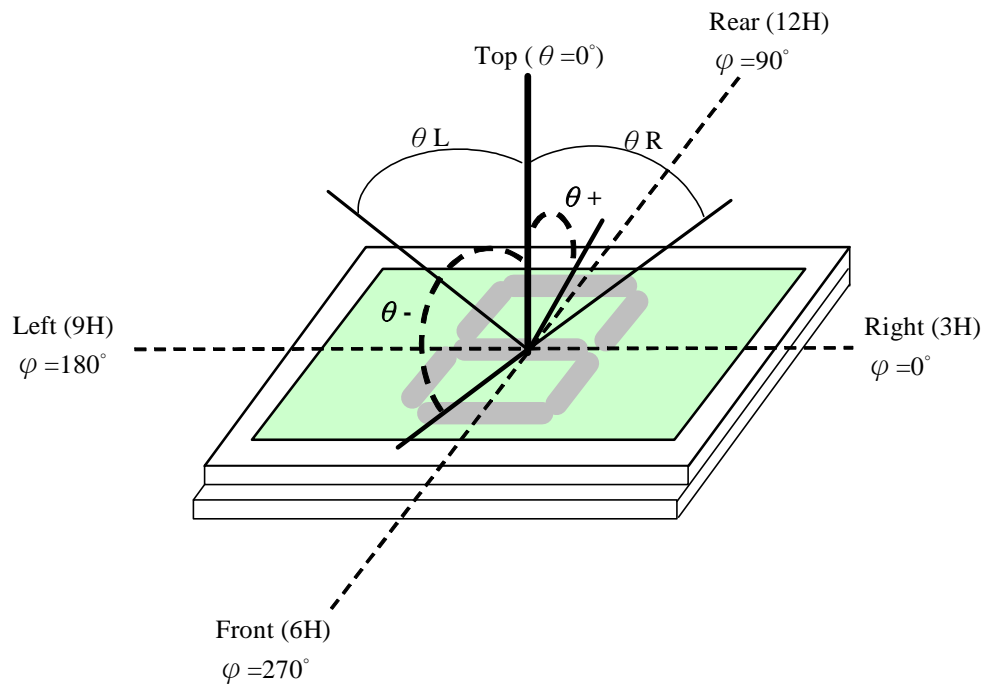

Viewing angle

Note 2.

Optical characteristics-3

Fig.2 Definition of response time

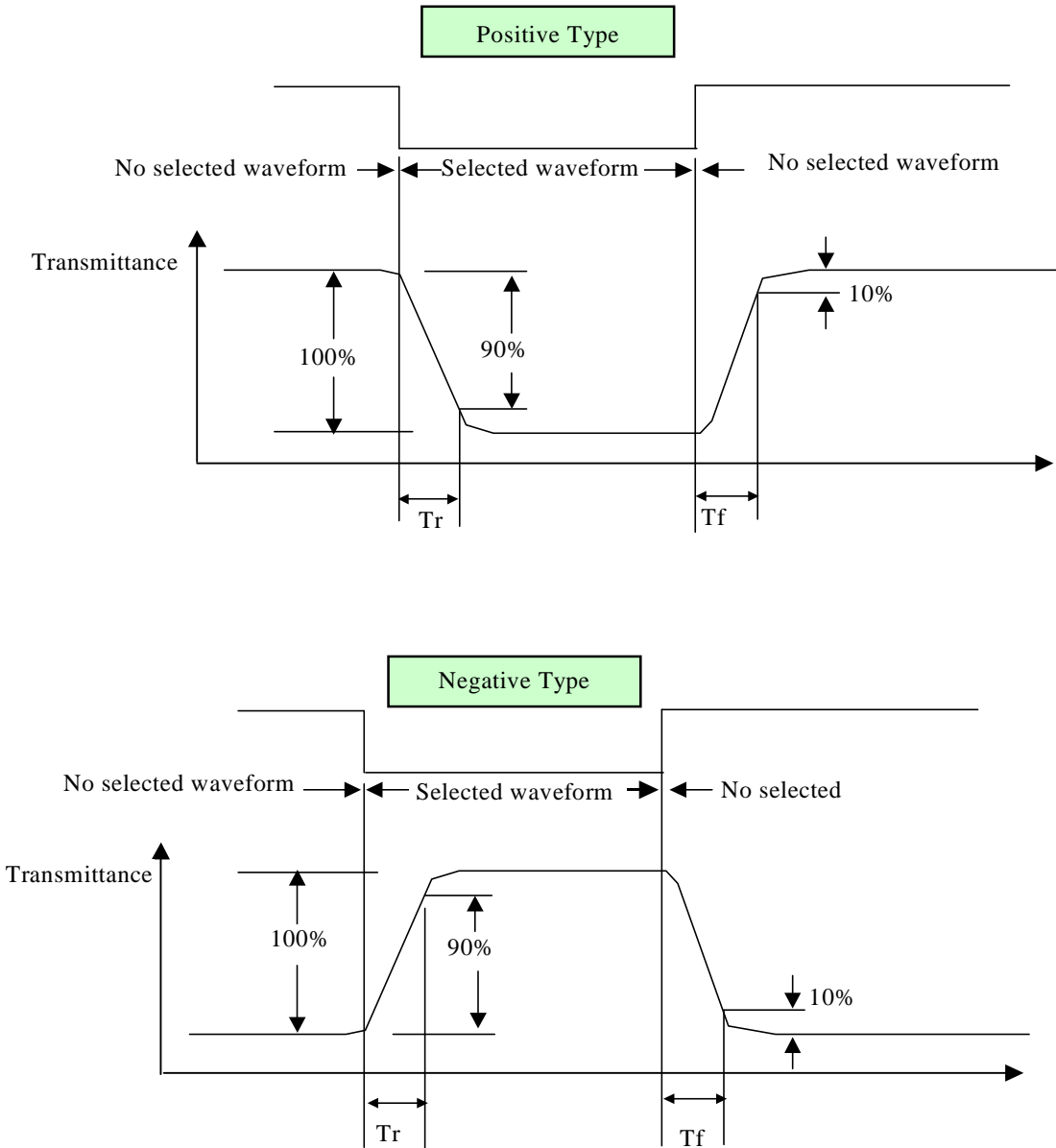

Electrical characteristics-2

※2 Drive waveform

V_{op} : Drive voltage

f_F : Frame frequency

$1/B$: Bias

f_D : Drive frequency

N : Duty

(1) Selected waveform

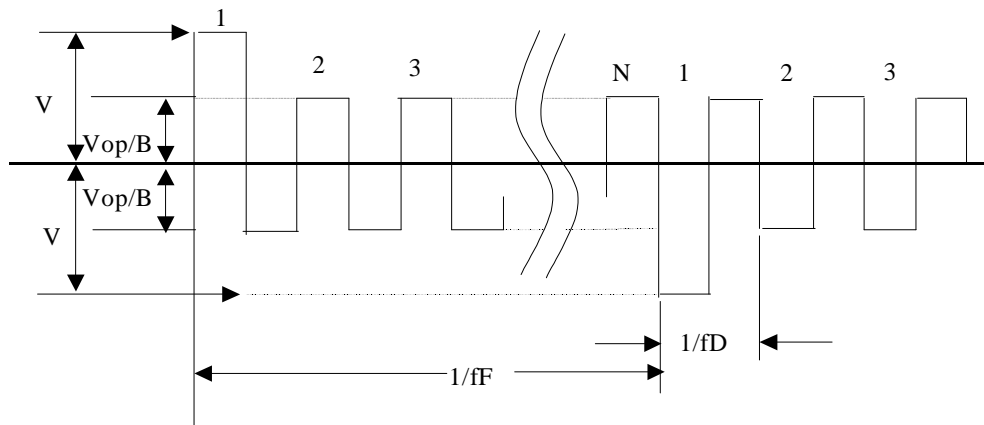

(2) Non- Selected wave form

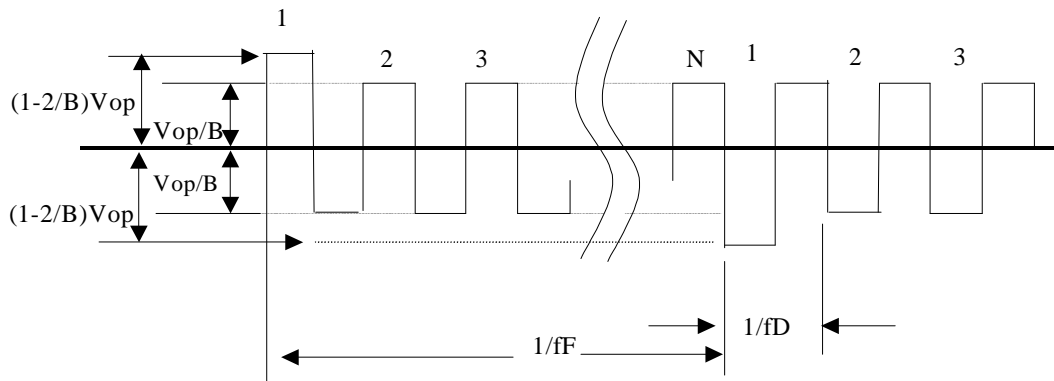

Note:

Frame frequency is defined as follows: Common side supply voltage peak - to - peak / 2 = 1 period

Note 3. : Definition of Vth

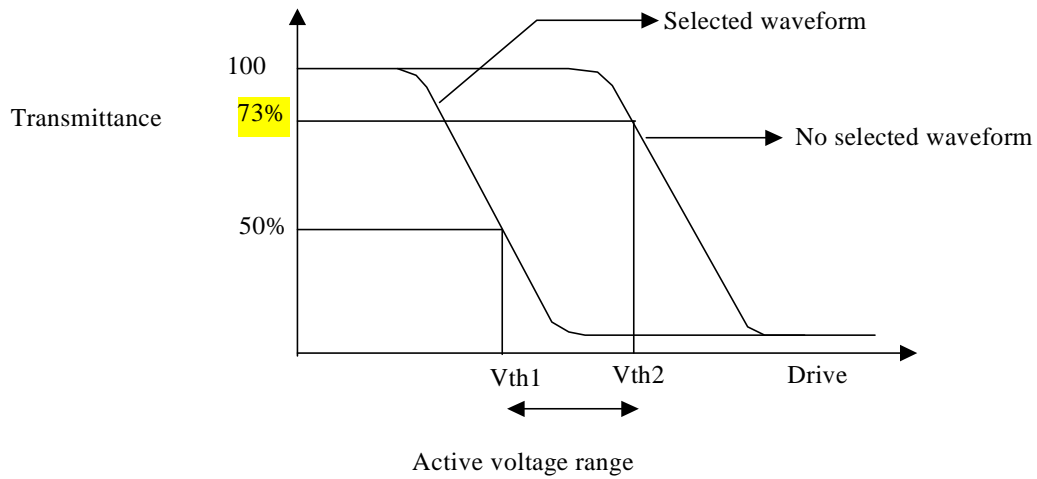

	Vth1	Vth2
View direction	10°	40°
Drive waveform	(Selected waveform)	(No selected waveform)
Transmittance	50%	73%

※1 Contrast ratio
 = (Brightness in OFF state) / (Brightness in ON state)

Outline of Electro-Optical Characteristics Measuring System

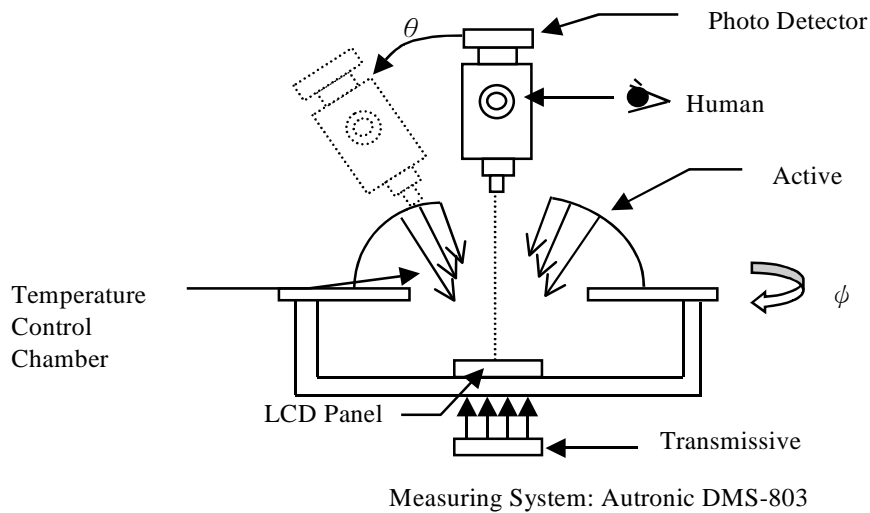

1.6 Backlight Characteristics

Maximum Ratings

Item	Symbol	Conditions	Min.	Max.	Unit
Peak Forward current	IF	Ta=25°C	-	100	mA
Power dissipation	Pd		-	0.24	W
Reverse Voltage	VR		-	5	V

Electrical / Optical Characteristics

Ta =25°C						
Item	Symbol	Conditions	Min.	Typ.	Max.	Unit
Forward Voltage	VF	IF=80mA	3.9	4.2	4.5	V
Reverse Current (Per LED)	IR	VR= 3V	-	-	10	uA
Average Brightness (Without LCD)	IV	IF=80mA	200	300	-	cd/m ²
CIE Color Coordinate (Without LCD)	X		0.24	0.27	0.30	-
	Y		0.24	0.27	0.31	-
Uniformity	△B		70	-	-	%
Color	White					

Internal Circuit Diagram:

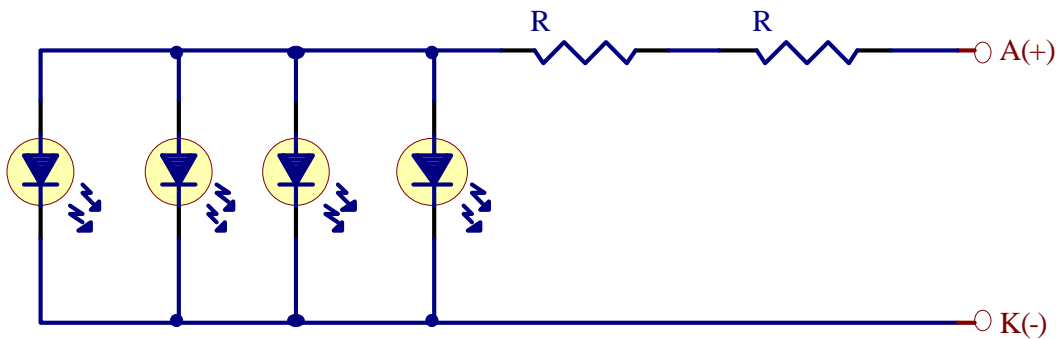

2. MODULE STRUCTURE

2.1 Counter Drawing

2.1.1 LCM Mechanical Diagram

* See Appendix

2.1.2 Block Diagram

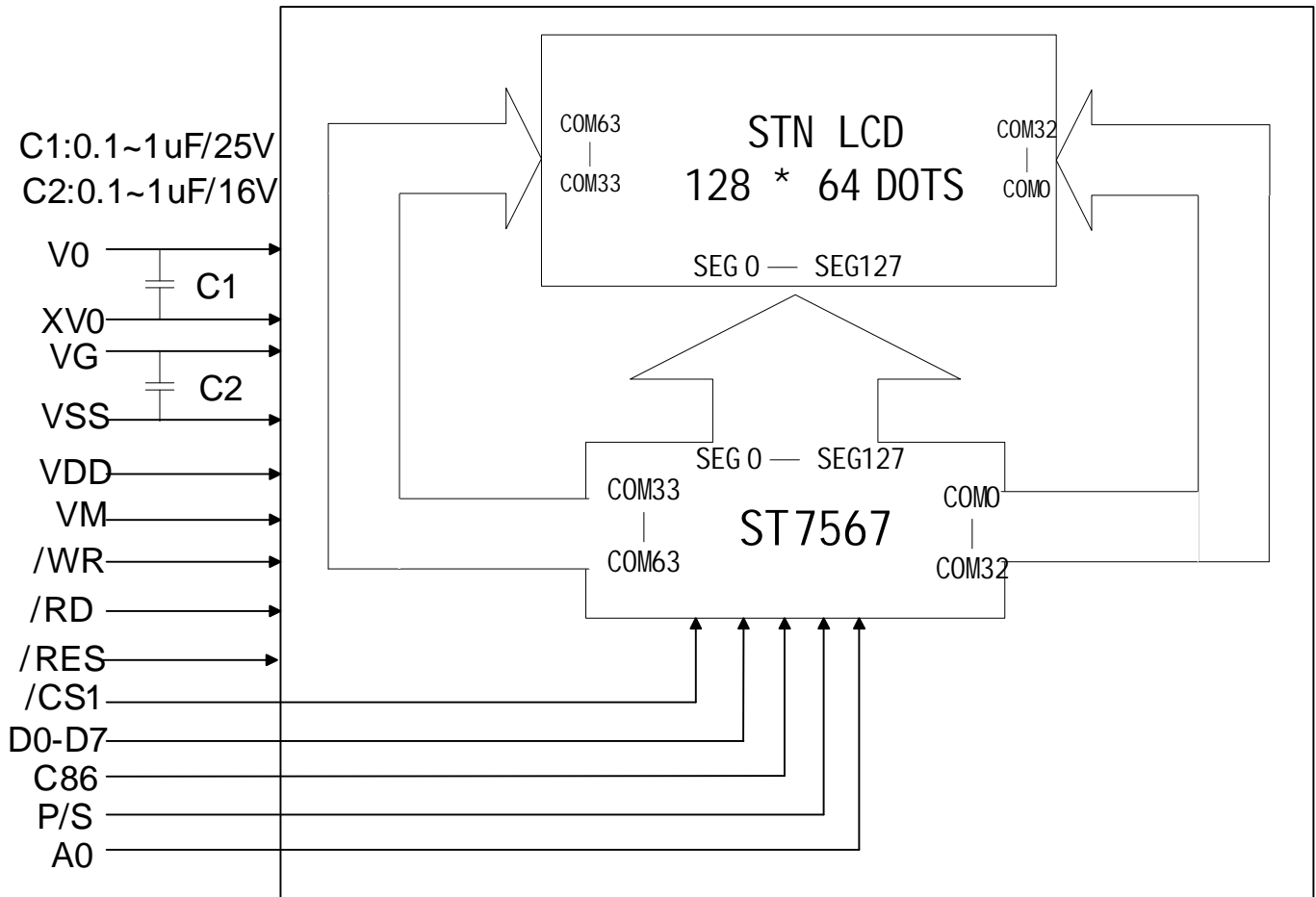

2.2 Interface Pin Description

Pin No.	Symbol	Function
1	/CS1	Chip select signal, Active "L".
2	/RES	Reset input pin. When /RES is "L", initialization is executed.
3	A0	It determines whether the access is related to data or command. A0= "H" : display data. A0=" L" : control data.
4	/WR	Write signal input, Active "L".
5	/RD	Read signal input, Active "L".
6	D0	8-bit bi-directional data bus.
7	D1	8-bit bi-directional data bus.
8	D2	8-bit bi-directional data bus.
9	D3	8-bit bi-directional data bus.
10	D4	8-bit bi-directional data bus.
11	D5	8-bit bi-directional data bus.
12	D6	8-bit bi-directional data bus.
13	D7	8-bit bi-directional data bus.
14	VDD	Power supply. (+3.0V)
15	VSS	System ground. (0V)
16	NC	Not connection. (Must be open)
17	NC	Not connection. (Must be open)
18	NC	Not connection. (Must be open)
19	V0	LCD driving voltage for commons at negative frame.
20	XV0	LCD driving voltage for commons at positive frame.
21	NC	Not connection. (Must be open)
22	NC	Not connection. (Must be open)
23	NC	Not connection. (Must be open)
24	NC	Not connection. (Must be open)
25	VM	LCD driving voltage for commons.

Pin No.	Symbol	Function												
26	NC	Not connection. (Must be open)												
27	NC	Not connection. (Must be open)												
28	NC	Not connection. (Must be open)												
29	VG	LCD driving voltage for segments.												
30	NC	Not connection. (Must be open)												
31	C86	Select the MPU system interface mode.												
32	P/S	<table border="1"> <thead> <tr> <th>P/S</th> <th>C86</th> <th>Interface</th> </tr> </thead> <tbody> <tr> <td>1</td> <td>1</td> <td>Parallel 68000 Series MPU Interface</td> </tr> <tr> <td>1</td> <td>0</td> <td>Parallel 8080 Series MPU Interface</td> </tr> <tr> <td>0</td> <td>X</td> <td>Serial 4-Line SPI Interface</td> </tr> </tbody> </table>	P/S	C86	Interface	1	1	Parallel 68000 Series MPU Interface	1	0	Parallel 8080 Series MPU Interface	0	X	Serial 4-Line SPI Interface
		P/S	C86	Interface										
		1	1	Parallel 68000 Series MPU Interface										
1	0	Parallel 8080 Series MPU Interface												
0	X	Serial 4-Line SPI Interface												
33	NC	Not connection. (Must be open)												
34	NC	Not connection. (Must be open)												

2.3 Timing Characteristic

System Bus Timing For 6800 Series MPU

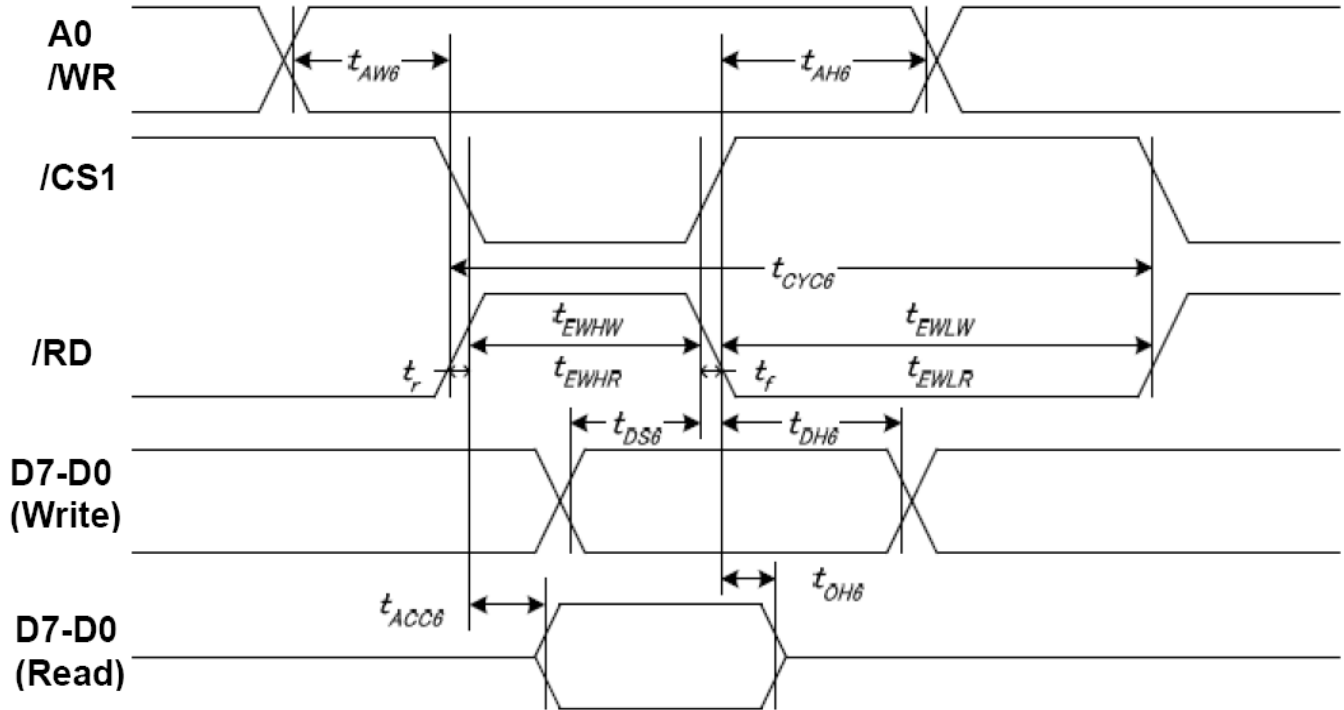

VDD = 3.3V, Ta = 25 °C

Item	Signal	Symbol	Condition	Min.	Max.	Unit
Address setup time	A0	tAW6		0	—	ns
Address hold time		tAH6		10	—	
System cycle time	/RD	tCYC6		240	—	
Enable L pulse width (WRITE)		tEHLW		80	—	
Enable H pulse width (WRITE)		tEHLR		80	—	
Enable L pulse width (READ)		tEHLR		80	—	
Enable H pulse width (READ)		tEHLR		140	—	
Write data setup time	D7-D0	tDHS6		40	—	
Write data hold time		tDHS6		10	—	
Read data access time		tACC6	CL = 16 pF	—	70	
Read data output disable time		tOHS6	CL = 16 pF	5	50	

VDD = 2.8V, Ta = 25 °C

Item	Signal	Symbol	Condition	Min.	Max.	Unit
Address setup time	A0	tAW6		0	—	ns
Address hold time		tAH6		0	—	
System cycle time	/RD	tCYC6		400	—	
Enable L pulse width (WRITE)		tEWLW		220	—	
Enable H pulse width (WRITE)		tEWHW		180	—	
Enable L pulse width (READ)		tEWLR		220	—	
Enable H pulse width (READ)		tEWHR		180	—	
Write data setup time		D7-D0	tDS6		40	
Write data hold time	tDH6			20	—	
Read data access time	tACC6		CL = 16 pF	—	140	
Read data output disable time	tOH6		CL = 16 pF	10	100	

Note 1. The input signal rise time and fall time (t_r , t_f) is specified at 15 ns or less. When the system cycle time is extremely fast, $(t_r + t_f) \leq (t_{CYC6} - t_{EWLW} - t_{EWHW})$ for $(t_r + t_f) \leq (t_{CYC6} - t_{EWLR} - t_{EWHR})$ are specified.

Note 2. All timing is specified using 20% and 80% of VDD1 as the reference.

Note 3. tEWLW and tEWLR are specified as the overlap between CSB being “L” and E.

System Bus Timing For 8080 Series MPU

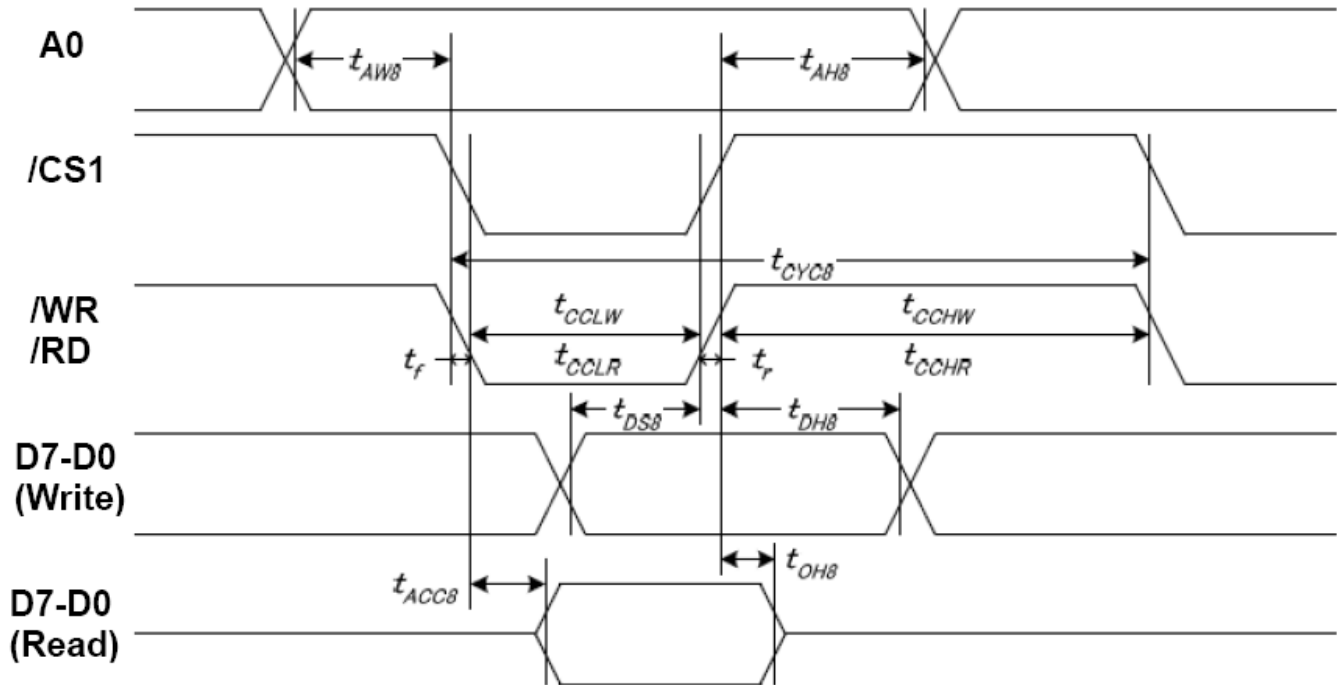

VDD = 3.3V, Ta = 25 °C

Item	Signal	Symbol	Condition	Min.	Max.	Unit
Address setup time	A0	tAW8		0	—	ns
Address hold time		tAH8		10	—	
System cycle time	/WR	tCYC8		240	—	
Enable L pulse width (WRITE)		tCCLW		80	—	
Enable H pulse width (WRITE)		tCCHW		80	—	
Enable L pulse width (READ)		/RD	tCCLR		140	
Enable H pulse width (READ)	tCCHR			80	—	
WRITE Data setup time	D7-D0	tDS8		40	—	
WRITE Data hold time		tDH8		20	—	
READ access time		tACC8	CL = 16 pF	—	70	
READ Output disable time		tOH8	CL = 16 pF	5	50	

VDD = 2.8V, Ta = 25 °C

Item	Signal	Symbol	Condition	Min.	Max.	Unit
Address setup time	A0	tAW8		0	—	ns
Address hold time		tAH8		0	—	
System cycle time	/WR	tCYC8		400	—	
/WR L pulse width (WRITE)		tCCLW		220	—	
/WR H pulse width (WRITE)	RD	tCCHW		180	—	
/RD L pulse width (READ)		tCCLR		220	—	
/RD H pulse width (READ)	tCCHR		180	—		
WRITE Data setup time	D[7:0]	tDS8		40	—	
WRITE Data hold time		tDH8		20	—	
READ access time		tACC8	CL = 16 pF	—	140	
READ Output disable time		tOH8	CL = 16 pF	10	100	

Note 1. The input signal rise time and fall time (t_r , t_f) is specified at 15 ns or less. When the system cycle time is extremely fast, $(t_r + t_f) \leq (t_{CYC8} - t_{CCLW} - t_{CCHW})$ for $(t_r + t_f) \leq (t_{CYC8} - t_{CCLR} - t_{CCHR})$ are specified.

Note 2. All timing is specified using 20% and 80% of VDD1 as the reference.

Note 3. tCCLW and tCCLR are specified as the overlap between CSB being “L” and WR and RD being at the “L” level.

System Bus Timing For 4-Line Serial Interface

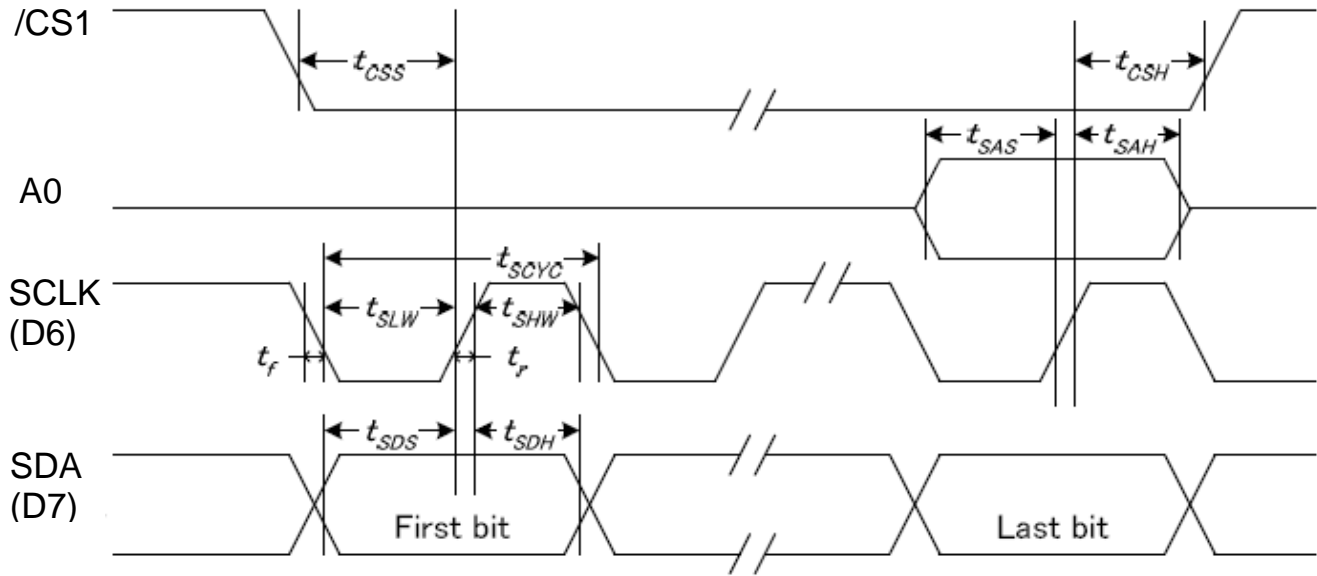

VDD = 3.3V, Ta = 25 °C

Item	Signal	Symbol	Condition	Min.	Max.	Unit
Serial clock period	SCLK	tSCYC		50	—	ns
SCLK "H" pulse width		tSHW		25	—	
SCLK "L" pulse width		tSLW		25	—	
Address setup time	A0	tSAS		20	—	
Address hold time		tSAH		10	—	
Data setup time	SDA	tSDS		20	—	
Data hold time		tSDH		10	—	
CSB-SCLK time	/CS1	tCSS		20	—	
CSB-SCLK time		tCSH		40	—	

VDD = 2.8V, Ta = 25 °C

Item	Signal	Symbol	Condition	Min.	Max.	Unit
Serial clock period	SCLK	tSCYC		100	—	ns
SCLK "H" pulse width		tSHW		50	—	
SCLK "L" pulse width		tSLW		50	—	
Address setup time	A0	tSAS		30	—	
Address hold time		tSAH		20	—	
Data setup time	SDA	tSDS		30	—	
Data hold time		tSDH		20	—	
CSB-SCLK time	/CS1	tCSS		30	—	
CSB-SCLK time		tCSH		60	—	

Note 1. The input signal rise and fall time (tr, tf) are specified at 15 ns or less.

Note 2. All timing is specified using 20% and 80% of VDD as the standard.

Reset Timing

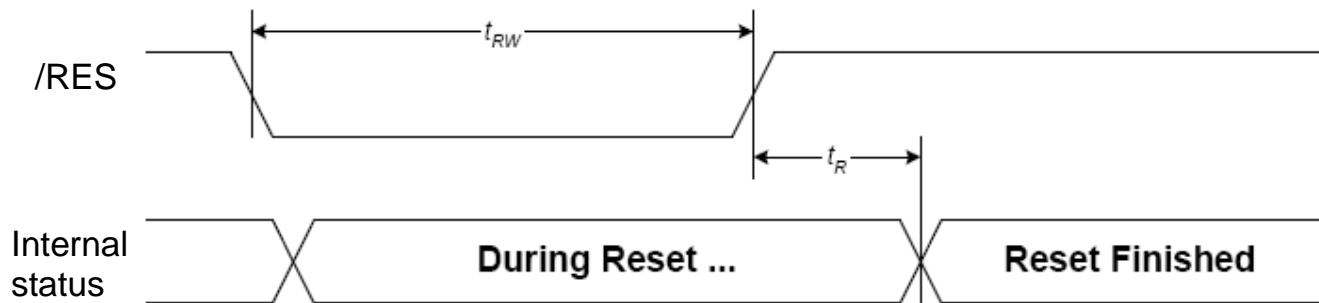

VDD = 3.3V, Ta = 25 °C

Item	Symbol	Condition	Min.	Max.	Unit
Reset time	tR		—	1.0	us
Reset "L" pulse width	tRW		1.0	—	

VDD = 2.8V, Ta = 25 °C

Item	Symbol	Condition	Min.	Max.	Unit
Reset time	tR		—	2.0	us
Reset "L" pulse width	tRW		2.0	—	

3. QUALITY ASSURANCE SYSTEM

3.1 Quality Assurance Flow Chart

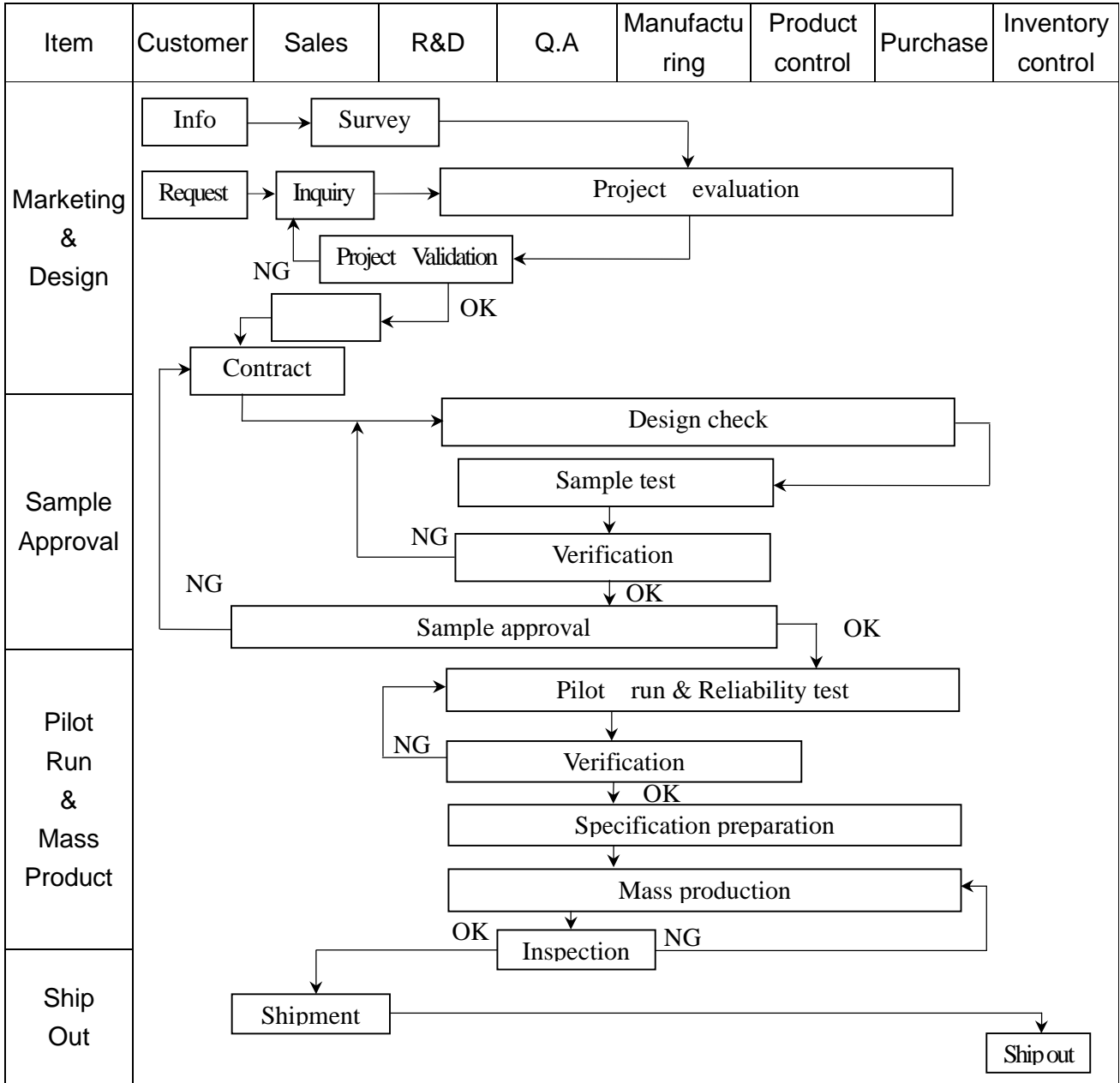

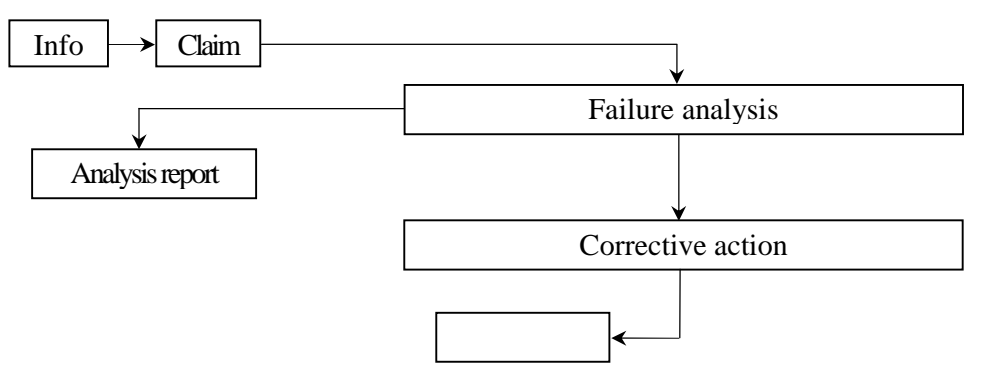
Item	Customer	Sales	R&D	Q.A	Manufacturing	Product control	Purchase	Inventory control
Sales Service	 <pre> graph TD Info[Info] --> Claim[Claim] Claim --> Failure[Failure analysis] Failure --> Report[Analysis report] Failure --> Action[Corrective action] Action --> Empty[] </pre>							
Q.A Activity	1. ISO 9001 Maintenance Activities 3. Equipment calibration 5. Standardization Management				2. Process improvement proposal 4. Education And Training Activities			

3.2. Inspection Specification

◆ Scope : The document shall be applied to LCD Module for Monotype and Color STN(Ver. B01).

◆ Inspection Standard : MIL-STD-105E Table Normal Inspection Single Sampling Level II .

◆ Equipment : Gauge 、 MIL-STD 、 Powertip Tester 、 Sample

◆ Defect Level : Major Defect AQL : 0.4 ; Minor Defect : AQL : 1.5 .

◆ OUT Going Defect Level : Sampling .

◆ Manner of appearance test :

(1). The test be under 20W×2 fluorescent light ' and distance of view must be at 30 cm.

(2). Standard of inspection : (Unit : mm)

(3). The test direction is base on about around 45° of vertical line. (Fig. 1)

(4). Definition of area . (Fig. 2)

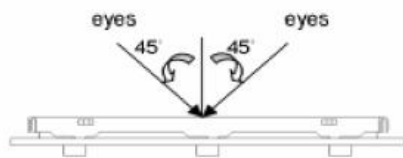

Fig.1

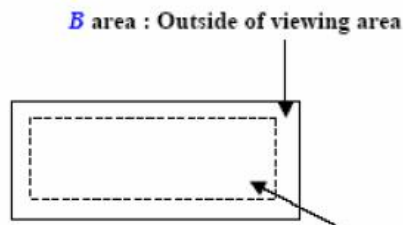
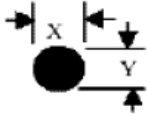
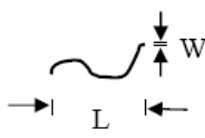
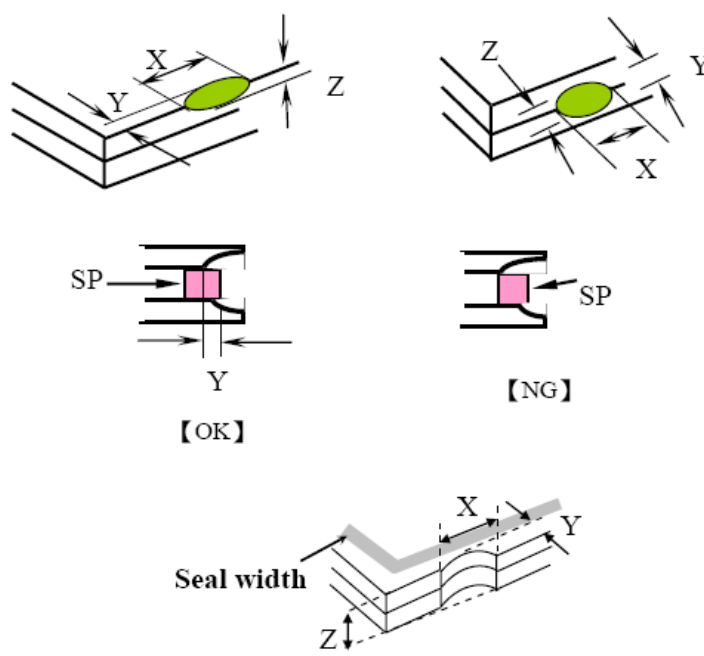

Fig. 2 A area : viewing area

◆ Specification:

NO	Item	Criterion	Level
01	Product condition	1. 1 The part number is inconsistent with work order of Production.	Major
		1. 2 Mixed production types.	Major
		1. 3 Assembled in inverse direction.	Major
02	Quantity	2. 1 The quantity is inconsistent with work order of production.	Major
03	Outline dimension	3. 1 Product dimension and structure must conform to Structure diagram.	Major
04	Electrical Testing	4. 1 Missing line character and icon.	Major
		4. 2 No function or no display.	Major
		4. 3 Output data is error.	Major
		4. 4 LCD viewing angle defect.	Major
		4. 5 Current consumption exceeds product specifications.	Major

NO	Item	Criterion	Level																																				
05	<p>Black or white dot、scratch、contamination</p> <p>Round type</p>  <p>$\Phi = (x+y)/2$</p> <p>Line type</p> 	<p>5. 1 Round type:</p> <p>5. 1. 1 display only :</p> <ul style="list-style-type: none"> • White and black spots on display ≤ 0.30 mm , no more than 4 white or black spots present. • Densely spaced : NO more than two spots or lines within 3 mm. <p>5. 1. 2 Non-display :</p> <table border="1"> <thead> <tr> <th rowspan="2">Dimension (diameter : Φ)</th> <th colspan="2">Acceptance (Q'ty)</th> </tr> <tr> <th>A area</th> <th>B area</th> </tr> </thead> <tbody> <tr> <td>$\Phi \leq 0.10$</td> <td colspan="2">Accept no dense</td> </tr> <tr> <td>$0.10 < \Phi \leq 0.20$</td> <td>3</td> <td rowspan="3">Ignore</td> </tr> <tr> <td>$0.20 < \Phi \leq 0.30$</td> <td>2</td> </tr> <tr> <td>Total quantity</td> <td>4</td> </tr> </tbody> </table> <p>5. 1. 3 Line type:</p> <table border="1"> <thead> <tr> <th colspan="2">Dimension</th> <th colspan="2">Acceptance (Q'ty)</th> </tr> <tr> <th>Length (L)</th> <th>Width (W)</th> <th>A area</th> <th>B area</th> </tr> </thead> <tbody> <tr> <td>---</td> <td>$W \leq 0.03$</td> <td>Accept no dense</td> <td rowspan="3">Ignore</td> </tr> <tr> <td>$L \leq 3.0$</td> <td>$0.03 < W \leq 0.05$</td> <td rowspan="2">4</td> </tr> <tr> <td>$L \leq 2.5$</td> <td>$0.05 < W \leq 0.075$</td> </tr> <tr> <td>---</td> <td>$W > 0.075$</td> <td colspan="2">As round type</td> </tr> </tbody> </table>	Dimension (diameter : Φ)	Acceptance (Q'ty)		A area	B area	$\Phi \leq 0.10$	Accept no dense		$0.10 < \Phi \leq 0.20$	3	Ignore	$0.20 < \Phi \leq 0.30$	2	Total quantity	4	Dimension		Acceptance (Q'ty)		Length (L)	Width (W)	A area	B area	---	$W \leq 0.03$	Accept no dense	Ignore	$L \leq 3.0$	$0.03 < W \leq 0.05$	4	$L \leq 2.5$	$0.05 < W \leq 0.075$	---	$W > 0.075$	As round type		Minor
Dimension (diameter : Φ)	Acceptance (Q'ty)																																						
	A area	B area																																					
$\Phi \leq 0.10$	Accept no dense																																						
$0.10 < \Phi \leq 0.20$	3	Ignore																																					
$0.20 < \Phi \leq 0.30$	2																																						
Total quantity	4																																						
Dimension		Acceptance (Q'ty)																																					
Length (L)	Width (W)	A area	B area																																				
---	$W \leq 0.03$	Accept no dense	Ignore																																				
$L \leq 3.0$	$0.03 < W \leq 0.05$	4																																					
$L \leq 2.5$	$0.05 < W \leq 0.075$																																						
---	$W > 0.075$	As round type																																					
06	<p>Polarizer Bubble</p>	<table border="1"> <thead> <tr> <th rowspan="2">Dimension (diameter : Φ)</th> <th colspan="2">Acceptance (Q'ty)</th> </tr> <tr> <th>A area</th> <th>B area</th> </tr> </thead> <tbody> <tr> <td>$\Phi \leq 0.20$</td> <td colspan="2">Accept no dense</td> </tr> <tr> <td>$0.20 < \Phi \leq 0.50$</td> <td>3</td> <td rowspan="3">Ignore</td> </tr> <tr> <td>$0.50 < \Phi \leq 1.00$</td> <td>2</td> </tr> <tr> <td>$\Phi > 1.00$</td> <td>0</td> </tr> <tr> <td>Total quantity</td> <td>4</td> <td></td> </tr> </tbody> </table>	Dimension (diameter : Φ)	Acceptance (Q'ty)		A area	B area	$\Phi \leq 0.20$	Accept no dense		$0.20 < \Phi \leq 0.50$	3	Ignore	$0.50 < \Phi \leq 1.00$	2	$\Phi > 1.00$	0	Total quantity	4		Minor																		
Dimension (diameter : Φ)	Acceptance (Q'ty)																																						
	A area	B area																																					
$\Phi \leq 0.20$	Accept no dense																																						
$0.20 < \Phi \leq 0.50$	3	Ignore																																					
$0.50 < \Phi \leq 1.00$	2																																						
$\Phi > 1.00$	0																																						
Total quantity	4																																						

NO	Item	Criterion	Level									
07	The crack of glass	<p>Symbols :</p> <p>X : The length of crack Y : The width of crack. Z : The thickness of crack W : terminal length t : The thickness of glass a : LCD side length</p> <hr/> <p>7.1 General glass chip :</p> <p>7.1.1 Chip on panel surface and crack between panels:</p>  <table border="1" data-bbox="535 1428 1282 1711"> <thead> <tr> <th>X</th> <th>Y</th> <th>Z</th> </tr> </thead> <tbody> <tr> <td>$\leq a$</td> <td>Crack can't enter viewing area</td> <td>$\leq 1/2 t$</td> </tr> <tr> <td>$\leq a$</td> <td>Crack can't exceed the half of SP width.</td> <td>$1/2 t < Z \leq 2 t$</td> </tr> </tbody> </table>	X	Y	Z	$\leq a$	Crack can't enter viewing area	$\leq 1/2 t$	$\leq a$	Crack can't exceed the half of SP width.	$1/2 t < Z \leq 2 t$	Minor
X	Y	Z										
$\leq a$	Crack can't enter viewing area	$\leq 1/2 t$										
$\leq a$	Crack can't exceed the half of SP width.	$1/2 t < Z \leq 2 t$										

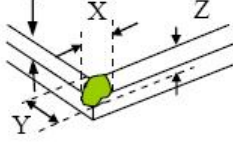
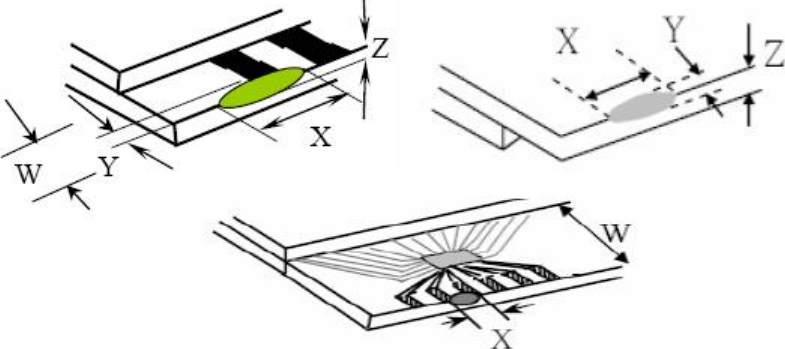
NO	Item	Criterion	Level									
07	The crack of glass	<p>Symbols :</p> <p>X : The length of crack Z : The thickness of crack t : The thickness of glass</p> <p>Y : The width of crack. W : terminal length a : LCD side length</p> <hr/> <p>7.1.2 Corner crack :</p>  <table border="1" data-bbox="537 800 1295 1073"> <thead> <tr> <th>X</th> <th>Y</th> <th>Z</th> </tr> </thead> <tbody> <tr> <td>$\leq 1/5 a$</td> <td>Crack can't enter viewing area</td> <td>$Z \leq 1/2 t$</td> </tr> <tr> <td>$\leq 1/5 a$</td> <td>Crack can't exceed the half of SP width.</td> <td>$1/2 t < Z \leq 2 t$</td> </tr> </tbody> </table>	X	Y	Z	$\leq 1/5 a$	Crack can't enter viewing area	$Z \leq 1/2 t$	$\leq 1/5 a$	Crack can't exceed the half of SP width.	$1/2 t < Z \leq 2 t$	Minor
		X	Y	Z								
$\leq 1/5 a$	Crack can't enter viewing area	$Z \leq 1/2 t$										
$\leq 1/5 a$	Crack can't exceed the half of SP width.	$1/2 t < Z \leq 2 t$										
<p>7.2 Protrusion over terminal :</p> <p>7.2.1 Chip on electrode pad :</p>  <table border="1" data-bbox="506 1619 1237 1780"> <thead> <tr> <th></th> <th>X</th> <th>Y</th> <th>Z</th> </tr> </thead> <tbody> <tr> <td>Front</td> <td>$\leq a$</td> <td>$\leq 1/2 W$</td> <td>$\leq t$</td> </tr> <tr> <td>Back</td> <td colspan="3">Neglect</td> </tr> </tbody> </table>		X	Y	Z	Front	$\leq a$	$\leq 1/2 W$	$\leq t$	Back	Neglect		
	X	Y	Z									
Front	$\leq a$	$\leq 1/2 W$	$\leq t$									
Back	Neglect											

◆ Specification For Monotype and Color STN :

(Ver. B01)

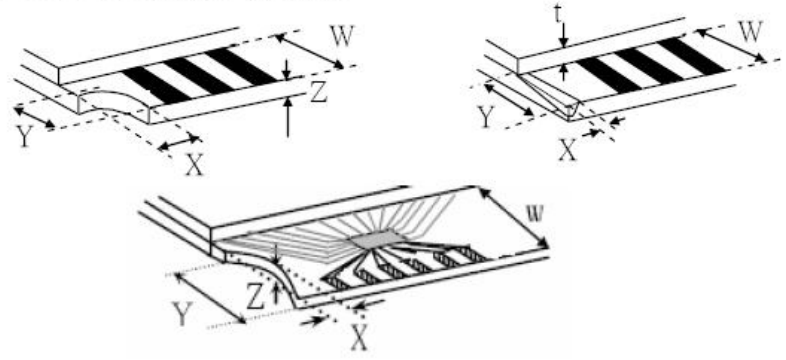
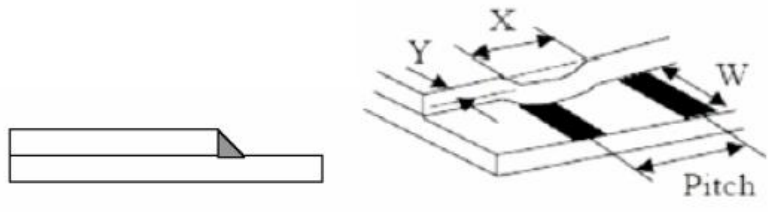
NO	Item	Criterion	Level									
07	The crack of glass	<p>Symbols :</p> <p>X : The length of crack Y : The width of crack. Z : The thickness of crack W : terminal length t : The thickness of glass a : LCD side length</p>	Minor									
		<p>7.2.2 Non-conductive portion :</p>  <table border="1" data-bbox="609 1018 1193 1165"> <thead> <tr> <th>X</th> <th>Y</th> <th>Z</th> </tr> </thead> <tbody> <tr> <td>$\leq 1/3 a$</td> <td>$\leq W$</td> <td>$\leq t$</td> </tr> </tbody> </table> <p>⊙ If the chipped area touches the ITO terminal, over 2/3 of the ITO must remain and be inspected according to electrode terminal specifications.</p> <p>7.2.3 Glass remain :</p>  <table border="1" data-bbox="535 1648 1177 1795"> <thead> <tr> <th>X</th> <th>Y</th> <th>Z</th> </tr> </thead> <tbody> <tr> <td>$\leq a$</td> <td>$\leq 1/3 W$</td> <td>$\leq t$</td> </tr> </tbody> </table>		X	Y	Z	$\leq 1/3 a$	$\leq W$	$\leq t$	X	Y	Z
X	Y	Z										
$\leq 1/3 a$	$\leq W$	$\leq t$										
X	Y	Z										
$\leq a$	$\leq 1/3 W$	$\leq t$										

◆ Specification For Monotype and Color STN :

(Ver. B01)

NO	Item	Criterion	Level
08	Backlight elements	8. 1 Backlight can't work normally.	Major
		8. 2 Backlight doesn't light or color is wrong.	Major
		8. 3 Illumination source flickers when lit.	Major
09	General appearance	9. 1 Pin type must match type in specification sheet.	Major
		9. 2 No short circuits in components on PCB or FPC.	Major
		9. 3 Product packaging must the same as specified on packaging specification sheet.	Minor
		9. 4 The folding and peeled off in polarizer are not acceptable.	Minor
		9. 5 The PCB or FPC between B/L assembled distance (PCB or FPC) is ≤ 1.5 mm.	Minor

5. PRECAUTION RELATING PRODUCT HANDLING

5.1 SAFETY

- 5.1.1 If the LCD panel breaks , be careful not to get the liquid crystal to touch your skin.
- 5.1.2 If the liquid crystal touches your skin or clothes , please wash it off immediately by using soap and water.

5.2 HANDLING

- 5.2.1 Avoid any strong mechanical shock which can break the glass.
- 5.2.2 Avoid static electricity which can damage the CMOS LSI—When working with the module , be sure to ground your body and any electrical equipment you may be using.
- 5.2.3 Do not remove the panel or frame from the module.
- 5.2.4 The polarizing plate of the display is very fragile. So , please handle it very carefully, do not touch , push or rub the exposed polarizing with anything harder than an HB pencil lead (glass , tweezers , etc.)
- 5.2.5 Do not wipe the polarizing plate with a dry cloth , as it may easily scratch the surface of plate.
- 5.2.6 Do not touch the display area with bare hands , this will stain the display area.
- 5.2.7 Do not use ketonics solvent & aromatic solvent. Use with a soft cloth soaked with a cleaning naphtha solvent.
- 5.2.8 To control temperature and time of soldering is $320 \pm 10^{\circ}\text{C}$ and 3-5 sec.
- 5.2.9 To avoid liquid (include organic solvent) stained on LCM

5.3 STORAGE

- 5.3.1 Store the panel or module in a dark place where the temperature is $25^{\circ}\text{C} \pm 5^{\circ}\text{C}$ and the humidity is below 65% RH.
- 5.3.2 Do not place the module near organics solvents or corrosive gases.
- 5.3.3 Do not crush , shake , or jolt the module.

5.4 TERMS OF WARRANTY

- 5.4.1 Applicable warrant period
The period is within thirteen months since the date of shipping out under normal using and storage conditions.
- 5.4.2 Unaccepted responsibility
This product has been manufactured to your company's specification as a part for use in your company's general electronic products. It is guaranteed to perform according to delivery specifications. For any other use apart from general electronic equipment, we cannot take responsibility if the product is used in nuclear power control equipment, aerospace equipment , fire and security systems or any other applications in which there is a direct risk to human life and where extremely high levels of reliability are required. and where extremely high levels of reliability are required.

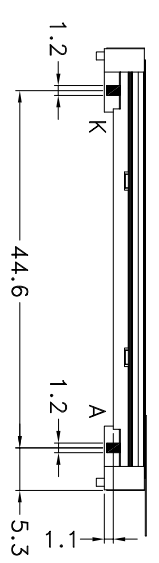
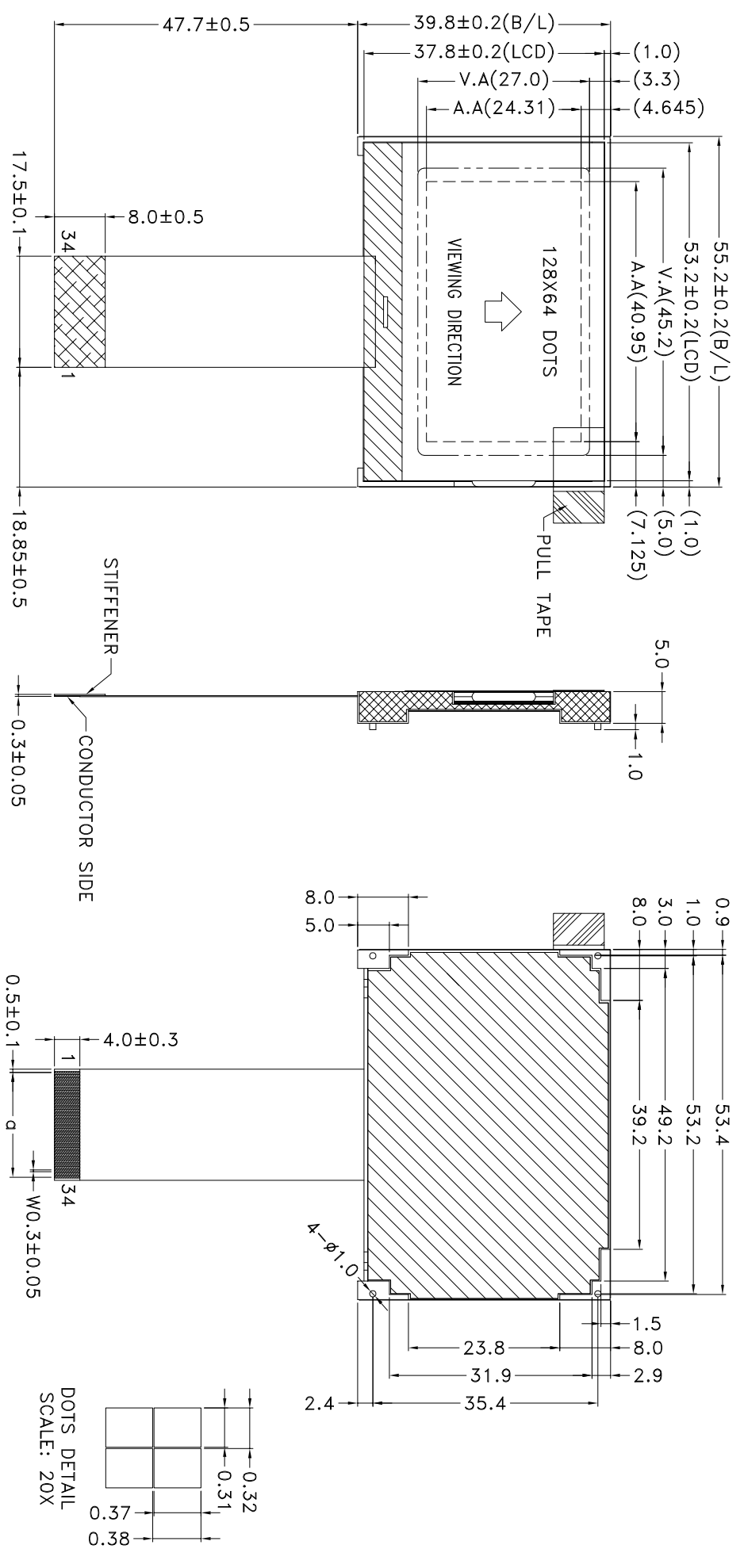

- NOTES:
- 1.LCD TYPE: FSTN
 - 2.LCD DISPLAY: POSITIVE/TRANSFLECTIVE
 - 3.VIEW DIRECTION: 6 O'CLOCK
 - 4.I.C No.: ST7567-G4
 - 5.THE TOLERANCE UNLESS CLASSIFIED $\pm 0.2\text{mm}$
 - 6.d: $P0.5 \times 33 = 16.5 \pm 0.05$

久正光電股份有限公司
POWER TIP TECHNOLOGY CORPORATION

007		PART NO:	PE12864WRF-055-H-Q	Design	Stone	Surface		Precision Level
006		DRAWING NAME :	LMD-PE12864WRF-055-H-Q	Check	Mag	Material		
005		TITLE:	LCD MODULE DRAWING	Approve	Linda	Thickness		
004		REV BY	Stone	DATE	2010/03/15	Quantity		
003		REV	REV BY	REVISER	DATE			
002								
001								
REV								

Ver.002

LCM包裝規格書

LCM Packaging Specifications (For Tray)

Documents NO: JPKG-PE12864WRF-055-H-Q

Approve	Check	Contact
Ryan	Eddy	Terry

1. 包裝材料規格表 (Packaging Material) : (per carton)

No.	Item	Model	Dimensions (mm)	1Pcs Weight	Quantity	Total Weight
1	成品 (LCM)	PE12864WRF-055-H-Q	55.2 X39.8X5.0	0.0115	360	4.14
2	多層薄膜(1)POF	OTFILM0BA03ABA	19"X350X0.015	—	6	—
3	TRAY 盤 (2)Tray	TYPE1286401ABA	352 X 260 X 10.8	0.1	36	3.6
4	內盒(3)Product Box	BX36627063ABBA	393 X 274 X 68	0.2692	6	1.6152
5	保利龍板(4)Polylon board	OTPLB00PL08ABA	550 X 393 X 20	0.0284	2	0.0568
6	外紙箱(5)Carton	BX57041027CCBA	570 X 410 X 265	1.4208	1	1.4208
7	FOAM	FOAM000000047	350 X 255 X 5	0.0018	12	0.0216
8						
9						

2. 一整箱總重量 (Total LCD Weight in carton) : 10.85 Kg±10% 取小數2位

3. 單箱數量規格表 (Packaging Specifications and Quantity) :

(1) LCM quantity per box : no per tray	12	x no of tray	5	=	60
(2) Total LCM quantity in carton : quantity per box	60	x no of boxes	6	=	360

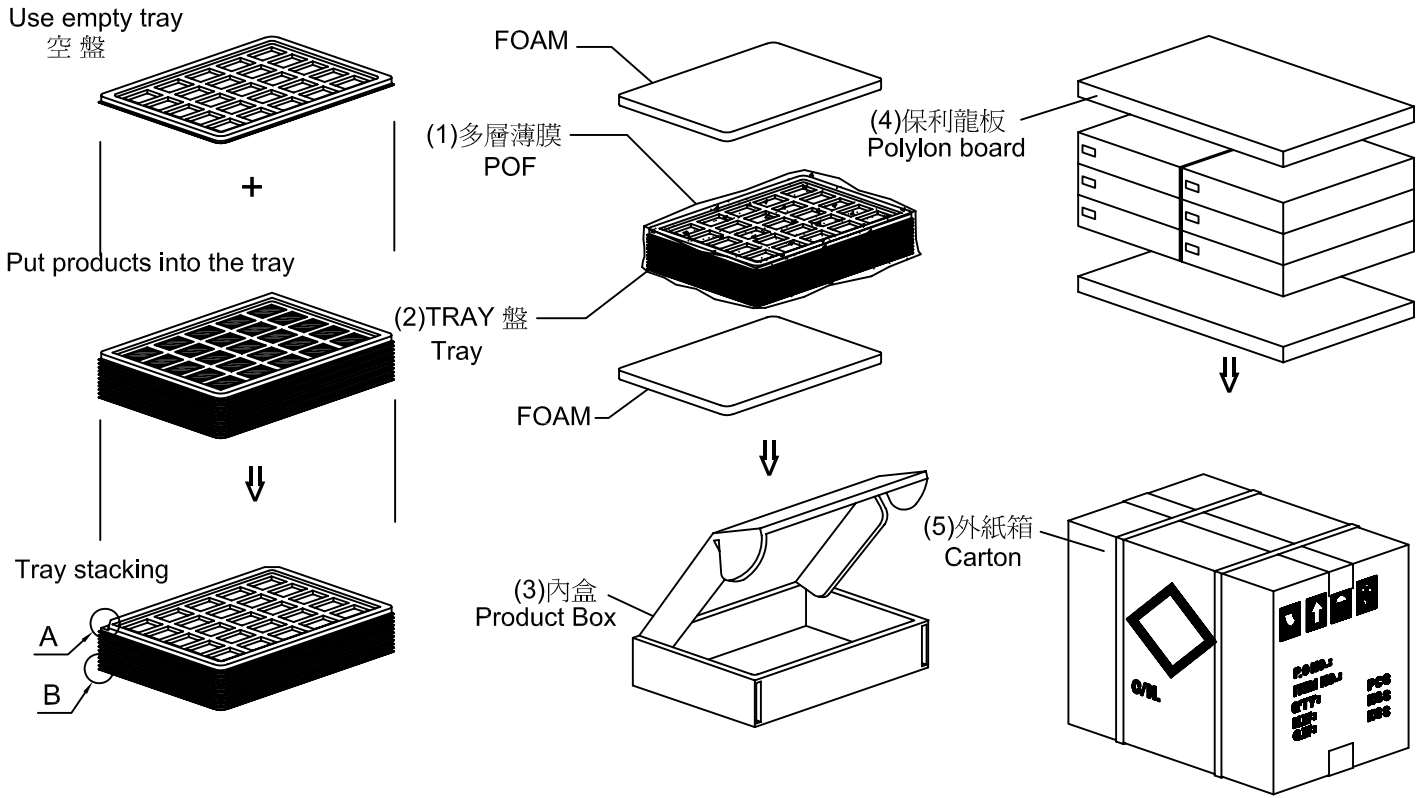

特 記 事 項 (REMARK)

1. Label Specifications :

MODEL:
 LOT NO:
 QUANTITY:
 CHECK:

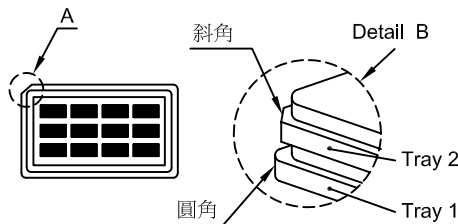

2. TRAY盤相疊時, 需旋轉180度, 請詳見B視圖
 Rotate tray 180 degrees and place on top of stack.
 Check the tray stack using Fig. B.