

P-Channel Enhancement Mode Power MOSFET

Description

The PE40P5 uses advanced trench technology to provide excellent $R_{DS(ON)}$. This device is suitable for use as a load switch and battery protection applications.

General Features

- $V_{DS} = -40V, I_D = -5.3A$
 $R_{DS(ON)} < 126m\Omega @ V_{GS} = -4.5V$
 $R_{DS(ON)} < 85m\Omega @ V_{GS} = -10V$
- High power and current handling capability
- Lead free product is acquired
- Surface mount package

Application

- Battery applications
- Load switch

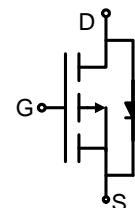

Schematic diagram

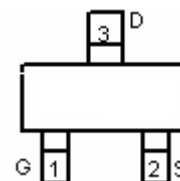

Marking and pin assignment



SOT-23-3L top view

Absolute Maximum Ratings ($T_A = 25^\circ C$ unless otherwise noted)

| Parameter | Symbol | Limit | Unit |
|--------------------------------------------------|----------------|------------|------------|
| Drain-Source Voltage | V_{DS} | -40 | V |
| Gate-Source Voltage | V_{GS} | ± 20 | V |
| Drain Current-Continuous | I_D | -5.3 | A |
| Drain Current-Pulsed (Note 1) | I_{DM} | -20 | A |
| Maximum Power Dissipation | P_D | 2.0 | W |
| Operating Junction and Storage Temperature Range | T_J, T_{STG} | -55 To 150 | $^\circ C$ |

Thermal Characteristic

| | | | |
|--------------------------------------------------|-----------------|------|--------------|
| Thermal Resistance, Junction-to-Ambient (Note 2) | $R_{\theta JA}$ | 62.5 | $^\circ C/W$ |
|--------------------------------------------------|-----------------|------|--------------|

Electrical Characteristics ($T_A = 25^\circ C$ unless otherwise noted)

| Parameter | Symbol | Condition | Min | Typ | Max | Unit |
|---------------------------------|------------|--------------------------------|-----|-----|-----|---------|
| Off Characteristics | | | | | | |
| Drain-Source Breakdown Voltage | BV_{DSS} | $V_{GS} = 0V, I_D = -250\mu A$ | -40 | - | - | V |
| Zero Gate Voltage Drain Current | I_{DSS} | $V_{DS} = -40V, V_{GS} = 0V$ | - | - | -1 | μA |

| Parameter | Symbol | Condition | Min | Typ | Max | Unit |
|-------------------------------------------|--------------|--------------------------------------------------------------|-----|------|-----------|------------|
| Gate-Body Leakage Current | I_{GSS} | $V_{GS}=\pm 20V, V_{DS}=0V$ | - | - | ± 100 | nA |
| On Characteristics (Note 3) | | | | | | |
| Gate Threshold Voltage | $V_{GS(th)}$ | $V_{DS}=V_{GS}, I_D=-250\mu A$ | -1 | -1.5 | -3 | V |
| Drain-Source On-State Resistance | $R_{DS(ON)}$ | $V_{GS}=-10V, I_D=-5A$ | - | 73 | 85 | m Ω |
| | | $V_{GS}=-4.5V, I_D=-4A$ | - | 98 | 126 | m Ω |
| Forward Transconductance | g_{FS} | $V_{DS}=-5V, I_D=-4.1A$ | 10 | - | - | S |
| Dynamic Characteristics (Note4) | | | | | | |
| Input Capacitance | C_{iss} | $V_{DS}=-20V, V_{GS}=0V,$ $F=1.0MHz$ | - | 650 | - | PF |
| Output Capacitance | C_{oss} | | - | 90 | - | PF |
| Reverse Transfer Capacitance | C_{rss} | | - | 70 | - | PF |
| Switching Characteristics (Note 4) | | | | | | |
| Turn-on Delay Time | $t_{d(on)}$ | $V_{DD}=-20V, R_L=2\Omega$ $V_{GS}=-10V, R_{GEN}=3\Omega$ | - | 9 | - | nS |
| Turn-on Rise Time | t_r | | - | 8 | - | nS |
| Turn-Off Delay Time | $t_{d(off)}$ | | - | 28 | - | nS |
| Turn-Off Fall Time | t_f | | - | 10 | - | nS |
| Total Gate Charge | Q_g | $V_{DS}=-20V, I_D=-3.1A,$ $V_{GS}=-10V$ | - | 14 | - | nC |
| Gate-Source Charge | Q_{gs} | | - | 2.9 | - | nC |
| Gate-Drain Charge | Q_{gd} | | - | 3.8 | - | nC |
| Drain-Source Diode Characteristics | | | | | | |
| Diode Forward Voltage (Note 3) | V_{SD} | $V_{GS}=0V, I_S=-2.5A$ | - | 0.8 | 1.2 | V |
| Diode Forward Current (Note 2) | I_S | | - | - | -5.3 | A |

Notes:

1. Repetitive Rating: Pulse width limited by maximum junction temperature.
2. Surface Mounted on FR4 Board, $t \leq 10$ sec.
3. Pulse Test: Pulse Width $\leq 300\mu s$, Duty Cycle $\leq 2\%$.
4. Guaranteed by design, not subject to production

Typical Electrical and Thermal Characteristics

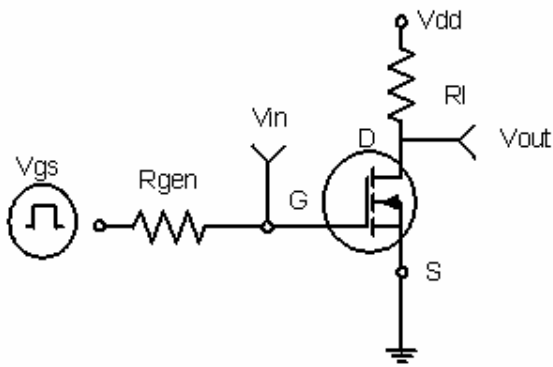

Figure 1: Switching Test Circuit

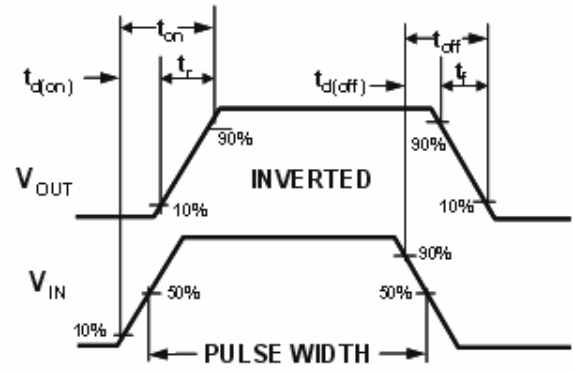
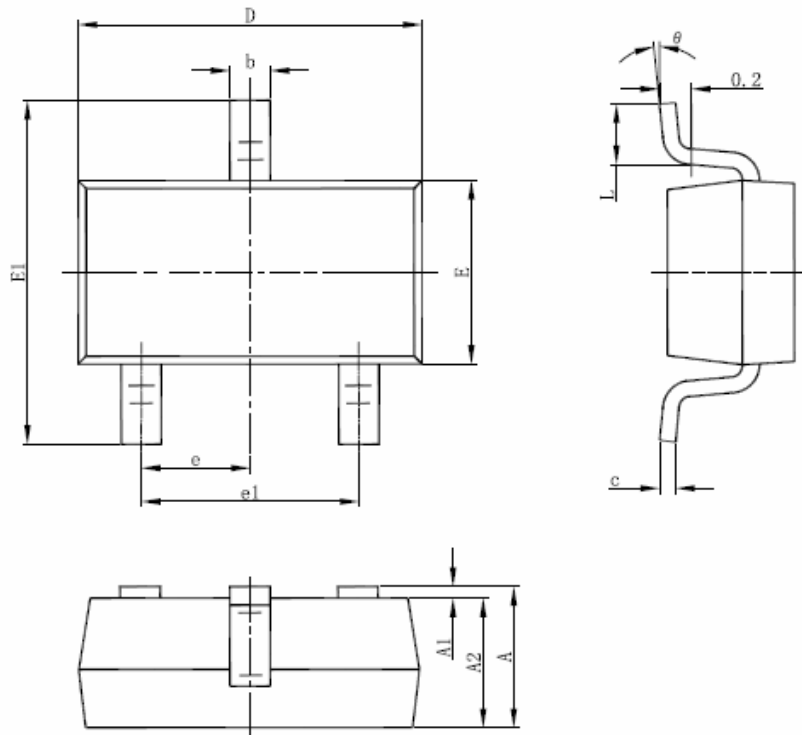

Figure 2: Switching Waveforms

SOT-23-3L Package Information



| Symbol | Dimensions In Millimeters | | Dimensions In Inches | |
|----------|---------------------------|-------|----------------------|-------|
| | Min | Max | Min | Max |
| A | 1.050 | 1.250 | 0.041 | 0.049 |
| A1 | 0.000 | 0.100 | 0.000 | 0.004 |
| A2 | 1.050 | 1.150 | 0.041 | 0.045 |
| b | 0.300 | 0.500 | 0.012 | 0.020 |
| c | 0.100 | 0.200 | 0.004 | 0.008 |
| D | 2.820 | 3.020 | 0.111 | 0.119 |
| E | 1.500 | 1.700 | 0.059 | 0.067 |
| E1 | 2.650 | 2.950 | 0.104 | 0.116 |
| e | 0.950(BSC) | | 0.037(BSC) | |
| e1 | 1.800 | 2.000 | 0.071 | 0.079 |
| L | 0.300 | 0.600 | 0.012 | 0.024 |
| θ | 0° | 8° | 0° | 8° |

Notes

1. All dimensions are in millimeters.
2. Tolerance $\pm 0.10\text{mm}$ (4 mil) unless otherwise specified
3. Package body sizes exclude mold flash and gate burrs. Mold flash at the non-lead sides should be less than 5 mils.
4. Dimension L is measured in gauge plane.
5. Controlling dimension is millimeter, converted inch dimensions are not necessarily exact.