

MATERIALS	
BODY	PASSIVATED STAINLESS STEEL
CONTACT	GOLD PLATED
INSULATOR	PTFE

www.DataSheet4U.com

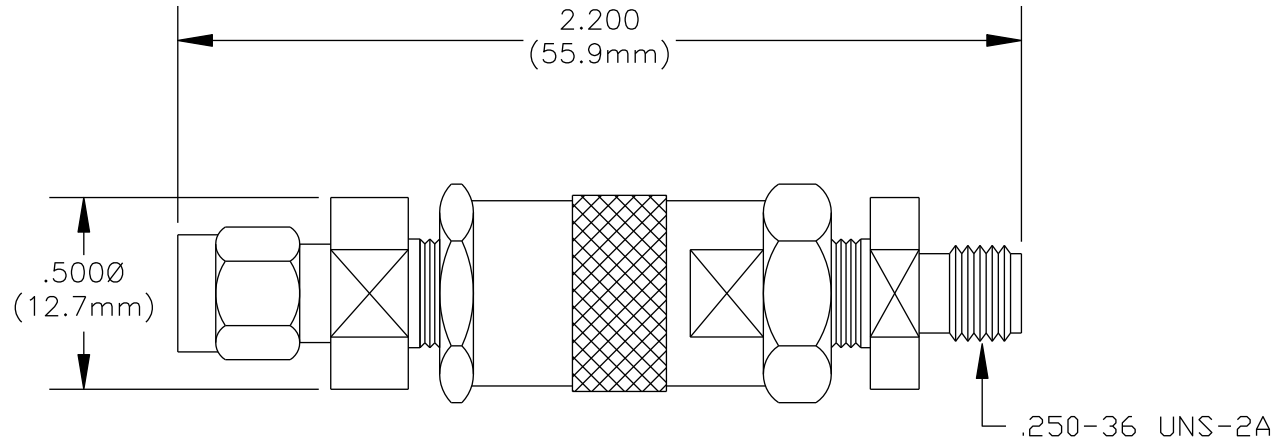

SPECIFICATIONS

IMPEDANCE: 50 OHMS

VSWR: 1.30:1 UP TO 18 GHz

INSERTION LOSS: .5 dB MAXIMUM AT 18 GHz

PHASE ADJUSTMENT RANGE: $9.5^\circ \times F$ (GHz)

FOR EXAMPLE..... 38° AT 4 GHz



PASTERNAK ENTERPRISES, INC.

P.O BOX 16759, IRVINE, CA 92623
PHONE (949) 261-1920 FAX (949) 261-7451

WEB ADDRESS: www.pasternack.com
E-MAIL ADDRESS: sales@pasternack.com

COAXIAL & FIBER OPTICS

DWG TITLE

PE8200

DES. SMA MALE TO SMA FEMALE ADJUSTABLE
PHASE TRIMER, FREQUENCY RANGE: DC TO
18 GHz

REV. - **FSCM NO. 53919**

CAD FILE 061008

SCALE N/A

SIZE A 127

NOTES:

1. UNLESS OTHERWISE SPECIFIED ALL DIMENSIONS ARE NOMINAL.
2. ALL SPECIFICATIONS ARE SUBJECT TO CHANGE WITHOUT NOTICE AT ANY TIME.
3. DIMENSIONS ARE IN INCHES.