

Product Description

The PE99153 DIE is a radiation tolerant point-of-load buck regulator delivering high efficiency at $V_{IN} = 5V$ and output currents up to 6A continuous. This single-chip solution is perfect for Hi-Rel applications and delivers peak efficiency exceeding 93%. A minimal external component count and high switching frequency enables $>10 W/in^2$ standard PCB designs while high efficiency minimizes thermal concerns. All power switching devices are integrated on-chip.

Fabricated in Peregrine’s patented UltraCMOS® technology, the PE99153 offers excellent power efficiency and intrinsic radiation tolerance.

Table 1. Radiation Performance

TID	100 kRad(Si)
SEL	$> 90 MeV \cdot cm^2/mg$
SEB	$> 90 MeV \cdot cm^2/mg$
SET	$> 90 MeV \cdot cm^2/mg$
SEFI	$> 90 MeV \cdot cm^2/mg$
SEGR	$> 90 MeV \cdot cm^2/mg$

SEL, SEB, SEGR, SEU, SEFI: None observed, Au/60 degrees
SET: No events exceeding 30 mV transient observed @ Au,
LET=90, 60 degrees and normal incidence

Hi-Rel 6A DC-DC Converter

**Radiation Tolerant UltraCMOS®
Monolithic Point-of-Load Synchronous
Buck Regulator with Integrated Switches**

Features

- Up to 6A continuous
- Output voltage range from 1.0–3.6V by external select resistors
- Input voltage range 4.6–6.0V
- Current mode control, pulse-by-pulse current limit, current sharing enabled and (N+K) redundancy compatible shutdown mode
- SYNC function, 100 kHz–5 MHz lock range with selectable 500 kHz / 1 MHz free running frequency
- Shutdown pin, Power Good output pin for supply sequencing
- Better than 1% typical initial accuracy (25°C)
- Control inputs compatible with TTL, LVTTTL, LVCMOS (2.5V and 3.3V) and 5V CMOS

Figure 1. Typical Application Diagram

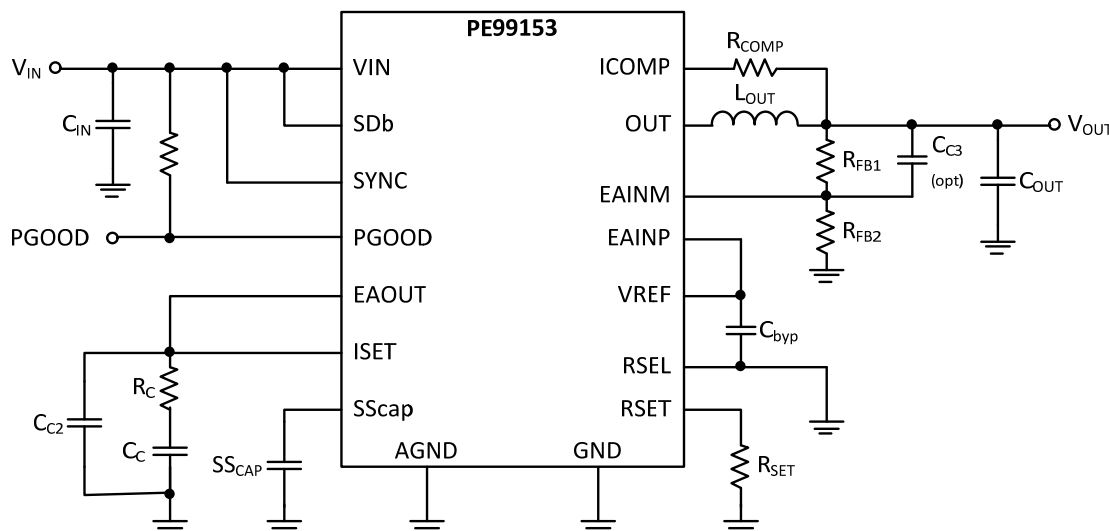

Table 2. Electrical Specifications¹
Temp (T_A) = -55 °C to +125 °C, V_{IN} = 4.6–6.0V, V_{OUT} = 1.0–3.6V, unless otherwise noted

Parameter	Condition	Min	Typ	Max	Unit
Synchronous Frequency Range, Fsw_range		0.1		5	MHz
Maximum Cycle-Averaged RMS Output Current, I_{max}		6			A
Supply Current (Shutdown), IDDS	SDB = GND, V _{IN} = 5.5V		2	6	mA
	SDB = GND, V _{IN} = 6.0V		0	9.5	mA
Supply Current (No-load, 1 MHz async), IDDO				55	mA
High Side On Resistance, R_{on,hss}	Test current = 100 mA		50	105	mΩ
Low Side On Resistance, R_{on,lss}	Test current = 100 mA		50	110	mΩ
Output Voltage					
Reference Voltage Accuracy, V_{ref} ²	V _{IN} = 5.0V, I _{OUT} = I _{max} /2, -40 ≤ T _A ≤ +85 °C, F _{sw} = 100 kHz–1 MHz	-1.00	0	1.00	%
	V _{IN} = 5.0V, I _{OUT} = I _{max} /2, -55 ≤ T _A ≤ +125 °C, F _{sw} = 100 kHz–1 MHz	-1.50	0	1.50	%
Reference Voltage Line Regulation, K_{vi} (steady state) ²	4.6V ≤ V _{IN} ≤ 6.0V, I _{OUT} = 3A, V _{OUT} = 2.5V, F _{sw} = 1 MHz	-0.20	0	0.20	%
Reference Voltage Load Regulation, K_{vo} (steady state) ²	V _{IN} = 5.0V, 500 mA ≤ I _{OUT} ≤ 3A, V _{OUT} = 2.5V, F _{sw} = 1 MHz	-0.25	0	0.25	%
Internal Oscillator and SYNC Capture					
Internal Oscillator Frequency, FOSC_FREQ	SYNC = GND	336	550	690	kHz
	SYNC = Open or V _{IN}	0.740	1.10	1.31	MHz
Internal Oscillator Duty Cycle, FOSC_DC		46		54	%
Min SYNC Lock Capture Frequency, Sync_lock		40			kHz
External Sync Duty Cycle, SYNC_DC		40		60	%
Current Limiting and Current Mode Control Loop					
Internal Current Limit Max, ILIMXINT ²	V _{OUT} = 1.0V, I _{SET} = 3.0V, I _{COMP} = 0V, RSEL pin shorted to ground, not min-on-time limited & F _{sw} = 500 kHz	6	8	9.5	A
Externally Set Max Current Limit Accuracy, ILIMXEXT ²	V _{OUT} = 1.0V, RSET = 82Ω, I _{SET} = 3.0V, I _{COMP} = 0V, RSEL = V _{IN} , not min-on-time limited. F _{sw} = 500 kHz	6	8	9.5	A
Maximum voltage across R _{SET} , V_{MAXRSET}		1.35	1.55	1.80	V
I _{out} /I _{rset} , G_{iref} ²	I _{OUT} set for 50% rated current	350	450	550	A/A
ICOMP cap, C_{ICOMP} ²			110		pF
Current compensation gain, ICOMP gain, G_{ICOMP} ²		4.3	6.5	8.7	A/V

Notes: 1. Wafer level screening is performed at +25 °C and +85 °C only. However, performance is guaranteed over the full operating temperature range based on a population of parts that were packaged and characterized at -55 °C and +125 °C.
2. Parameter not tested at wafer level due to high current limitations of test setup.

Table 2. Electrical Specifications* (Continued)

Temp (T_A) = -55 to $+125^\circ\text{C}$, $V_{IN} = 4.6$ – 6.0V , $V_{OUT} = 1.0$ – 3.6V , unless otherwise noted

Parameter	Condition	Min	Typ	Max	Unit
PGOOD					
PGOOD Threshold	EAINM_UP_THRESH entering PGOOD window (% of Vref)	104	110.5	117.5	%
	EAINM_LO_THRESH exiting PGOOD window (% of Vref)	84	90	96	%
PGOOD Hysteresis	EAINM_UP (% of Vref)		2		%
	EAINM_LO		1.7		%
PGOOD low sink current, PGOOD I_OL	$V_{PGOOD} = 0.4\text{V}$	4	8		mA
PGOOD high leakage current, PGOOD I_OH	$V_{PGOOD} = V_{IN}$		10	20	μA
PGOOD Deglitch Time			64		SYNCOB cycles
Error Amp					
EAINM leakage	Measured at 1V input			0.2	μA
EAINP leakage	Measured at 1V input			0.2	μA
EAOUT Source Current	Measured at 1V input	-445	-350	-270	μA
EAOUT Sink Current	Measured at 1V input	125	220	270	μA
Error Amplifier Transconductance	EAOUT = 1.5V DC	0.7	1.4	2.1	mS
Error Amplifier Output Resistance		4	6.4	10	$\text{M}\Omega$
EA Input offset	1 MHz internal	-6	3.1	6	mV
Undervoltage Lockout					
Undervoltage Lockout	V_{IN} Rising	3.5	4.2	4.59	V
	V_{IN} Falling	3.4	3.8	4.1	V
Undervoltage Lockout Hysteresis			400		mV
Soft Start					
SsCap pin pull-up Resistance	$V_{SSCap} = 0\text{V}$		1.2		$\text{M}\Omega$
Internal SSCAP			16		pF
Vref Track, V_SScap – Vref_ext	$V_{SSCap} = 0.5\text{V}$	-170	0	170	mV
DC Characteristics					
SDb turn-on threshold	V_{IH}	2			V
	V_{IL}			1.3	V
SYNCOB low sink current, SYNCOB I_OL	$V_{SYNCOB} = 0.4$	4	8		mA
SYNCOB high leakage current, SYNCOB I_OH	$V_{SYNCOB} = V_{IN}$		9.6	20	μA
SYNC	V_{IH}	2.2			V
	V_{IL}			1.25	V
HSS Leakage	$V_{OUT} = V_{SDb} = 0\text{V}$	-1.6	-0.01		mA
LSS Leakage	$V_{OUT} = V_{IN}$, $V_{SDb} = 0\text{V}$		0.3	1.8	mA

Note: * Wafer level screening is performed at 25°C and 85°C only. However, performance is guaranteed over the full operating temperature range based on a population of parts that were packaged and characterized at -55°C and $+125^\circ\text{C}$.

Figure 2. Pin Layout (Top View)*

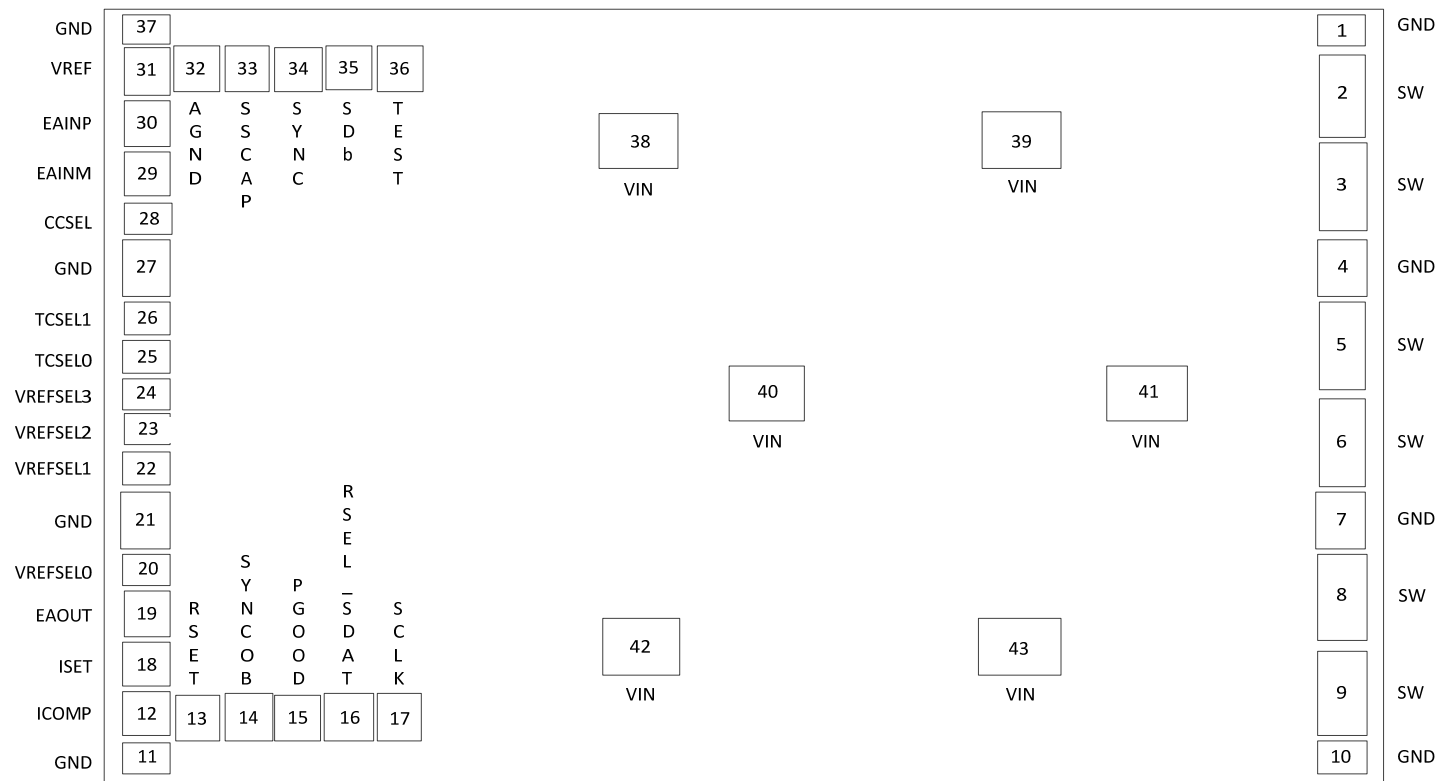

Note: * All pin locations originate from the die center and refer to the center of the pin.

Table 3. Pin Coordinates and Descriptions

Pin No.	Pin Name	X	Y	Description
1	GND	2385.9	1433.4	Ground
2	SW	2366.9	1179.65	Switch
3	SW	2366.9	810.35	Switch
4	GND	2365.9	500	Ground
5	SW	2366.9	189.65	Switch
6	SW	2366.9	-189.65	Switch
7	GND	2365.9	-500	Ground
8	SW	2366.9	-810.35	Switch
9	SW	2366.9	-1179.65	Switch
10	GND	2385.9	-1433.4	Ground
11	GND	-2343.9	-1437.25	Ground
12	ICOMP	-2343.9	-1266.9	Variable Current Compensation/Resistor to VOUT
13	RSET	-2142.8	-1283.2	Resistor to Set Reference Current
14	SYNCOB	-1944.2	-1283.2	Loop-Through Complement Output

Pin No.	Pin Name	X	Y	Description
15	PGOOD	-1745.6	-1283.2	Power Good Flag Output
16	RSEL_SDAT	-1547	-1283.2	Reference Resistor Selection
17	SCLK	-1348.4	-1283.2	Ground
18	ISET	-2343.9	-1068.3	Current Set-Point Input/ Loop to EAOUT
19	EAOUT	-2343.9	-869.7	Error Amplifier Output/ Loop ISET
20	VREFSELO	-2343.9	-696.1	Bandgap Reference Voltage Fine Adjust (0)
21	GND	-2343.9	-500	Ground
22	VREFSEL1	-2343.9	-297.3	Bandgap Reference Voltage Fine Adjust (1)
23	VREFSEL2	-2343.9	-148.7	Bandgap Reference Voltage Fine Adjust (2)
24	VREFSEL3	-2343.9	-0.1	Bandgap Reference Voltage Fine Adjust (3)

Table 3. Pin Coordinates and Descriptions (continued)

Pin No.	Pin Name	X	Y	Description
25	TCSEL0	-2343.9	148.5	Bandgap Reference Voltage Fine Adjust (0)
26	TCSEL1	-2343.9	297.2	Bandgap Reference Voltage Fine Adjust (0)
27	GND	-2343.9	500	Ground
28	CCSEL	-2343.9	696.1	Course trim code
29	EAINM	-2343.9	869.7	Error Amplifier (-) Input, Loop to VREF
30	EAINP	-2343.9	1068.3	Error Amplifier (+) Input, Load Feedback
31	VREF	-2343.9	1266.9	1.000V Reference output, Loop to AAINP. Additional Low Pass Filtering May be Necessary
32	AGND	-2142.8	1283.2	Bandgap ground
33	SScap	-1944.2	1283.2	Resistor to Set Reference Current
34	SYNC	-1745.6	1283.2	Loop-Through Complement Output
35	SDb	-1547	1283.2	Shutdown (L)/enable input
36	TEST	-1348.4	1283.2	Ground
37	GND	-2343.9	1437.25	Ground
38	V _{IN}	-397.5	1000	Input Power Supply
39	V _{IN}	1102.5	1000	Input Power Supply
40	V _{IN}	102.5	0	Input Power Supply
41	V _{IN}	1602.5	0	Input Power Supply
42	V _{IN}	-397.5	-1000	Input Power Supply
43	V _{IN}	1102.5	-1000	Input Power Supply

Table 4. Operating Ranges

Symbol	Parameter/Condition	Min	Max	Unit
V _{IN}	Power supply voltage	4.6	6.0	V
T _A	Operating temperature range (case)	-55	+125	°C

Table 5. Absolute Maximum Ratings

Symbol	Parameter/Condition	Min	Max	Unit
V _{IN}	Power supply voltage	-0.5	6.5	V
T _J	Operating temperature range (junction)	-55	+145	°C
T _{ST}	Storage temperature range (case)	-65	+150	°C
I _I	DC into any signal input	-10	10	mA
I _O	DC into any signal output	-50	50	mA
I _P	DC into any <i>single</i> power pin	-2	2	A

Exceeding absolute maximum ratings may cause permanent damage. Operation between maximum operating ranges and absolute maximum operating ranges for extended periods may reduce reliability.

Table 6. Electrostatic Discharge (ESD) Ratings

Model	Parameter/Condition	Min	Max	Unit
HBM*	V _{ESD} All pins		1000	V

Note: * Human Body Model ESD Voltage (HBM, MIL-STD 883 Method 3015.7).

Electrostatic Discharge (ESD) Precautions

When handling this UltraCMOS device, observe the same precautions that you would use with other ESD-sensitive devices. Although this device contains circuitry to protect it from damage due to ESD, precautions should be taken to avoid exceeding the specified rating.

Latch-Up Immunity

Unlike conventional CMOS devices, UltraCMOS devices are immune to latch-up.

ELDRS

The UltraCMOS process does not exhibit enhanced low-dose-rate sensitivity (ELDRS) since bipolar minority carrier elements are not used.

Typical Performance Characteristics

Figure 3. Efficiency Curves Over Output Load Current and Temperature*

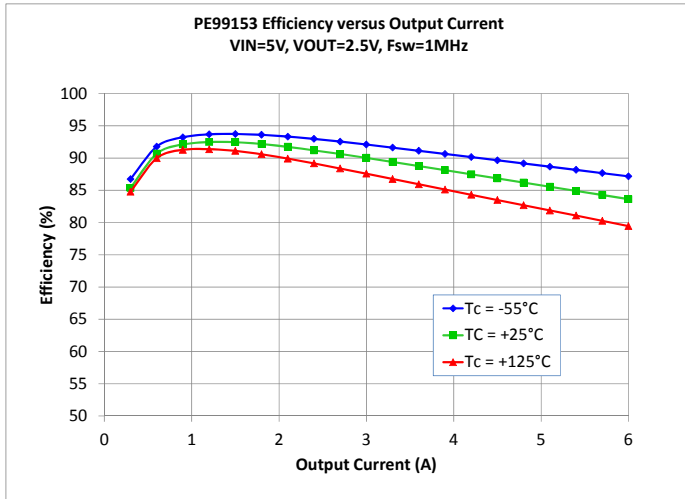
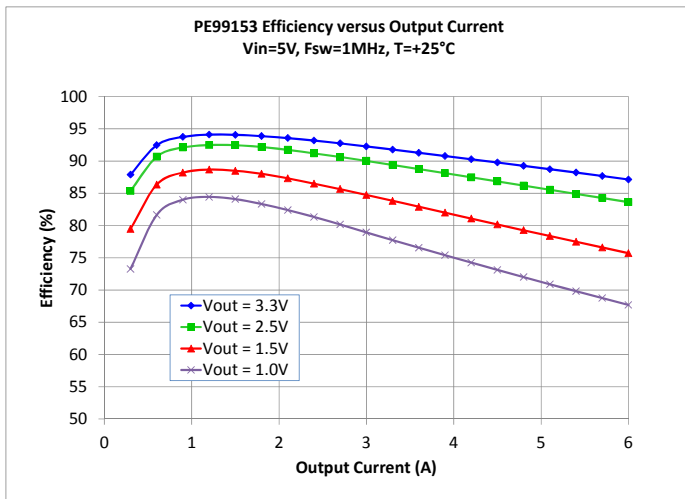
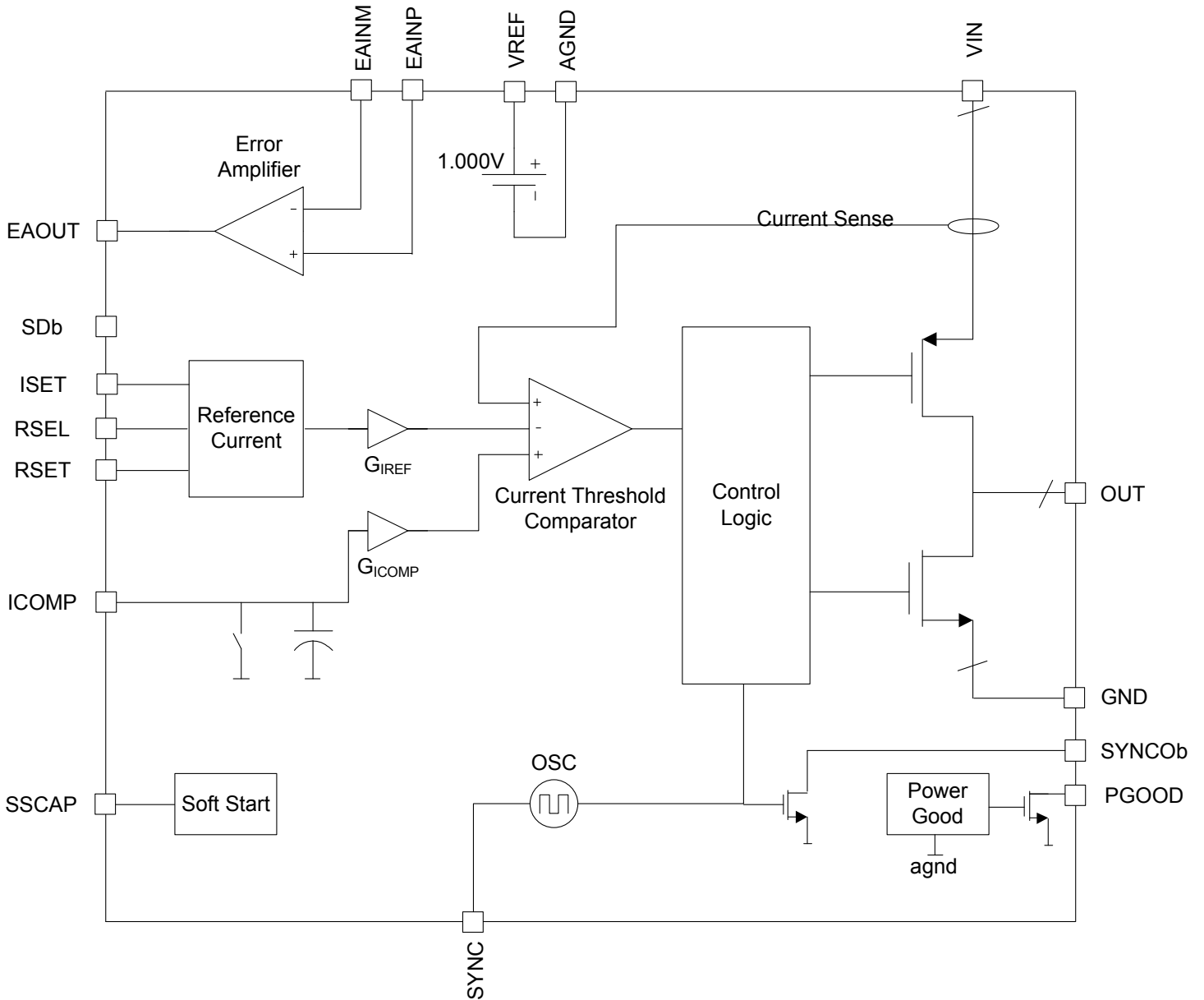

Figure 4. Efficiency Curves Over Typical Output Voltages*



Note: * The efficiency curves in Figures 3 and 4 were measured on the packaged parts.

Figure 5. Block Diagram



Theory of Operation

General

The PE99153 is a radiation-hardened point-of-load buck regulator. This highly integrated switching regulator contains two synchronous power switches capable of delivering up to 6A of continuous current. The PE99153 is designed to operate from a wide 5V bus and provide 1.0V to 3.6V supply rails for analog, digital and RF payloads. The internal oscillator can operate at 500 kHz or 1 MHz. Optionally, the switching frequency can be synchronized to an external reference from 100 kHz to 5 MHz. Current limiting is adjustable with an external resistor and is achieved through peak current mode control. An external resistor also provides adjustable slope compensation to optimize stability and closed loop bandwidth across output voltage and switching frequency range. Loop compensation is externally adjustable to meet application transient response while still maintaining stability requirements. The output is tri-stated when the SDB pin is low to enable hot-spare capability.

Peak Current Mode Control Loop

The PE99153 uses a peak current mode control architecture. At the falling edge of either the internal oscillator or, if present, the external reference, the high side switch turns on. The input voltage is then connected to the load voltage through the high side switch and the inductor for a time greater than the minimum-on-time. Current in the inductor begins to ramp approximately as $(V_{IN} - V_{OUT}) / L$. Energy is stored in the inductor during this period. As the inductor current rises, current through the high side switch is sensed and compared to a current threshold. The inductor current continues to ramp until the current threshold is reached. At this point the high side switch turns off and the low side switch turns on for at least the minimum-off-time. Energy stored in the inductor during the previous phase is discharged into the load supply rail through the low side switch and the inductor. Inductor current decreases at a rate of approximately V_{OUT}/L . The low side switch stays on until the next falling edge of the reference clock. In order to prevent unintended harmonics or spurs, the part does not exit continuous conduction mode.

Whether the current threshold was met in the previous clock cycle or not, a minimum-off-time, followed by a minimum-on-time immediately follows the falling edge of the reference clock.

While providing improved bandwidth and inherent current limiting, all current mode control switching regulators require slope compensation to ensure stability across all application conditions. The PE99153 provides adjustable

slope compensation to allow the designer to optimize transient response and stability requirements. The compensation ramp is provided through the ICOMP pin. Inboard of the ICOMP pin is the CCOMP capacitor which can be used to generate an RC compensation ramp by tying the ICOMP pin to either V_{OUT} or V_{IN} through an external resistor to produce the desired ramp. See the design guide for selection of the appropriate resistor value. The RC ramp is reset anytime the low side switch is on by a FET switch.

Current Threshold and Over Current Protection

The current mode control threshold current is set by the ISET pin which is driven by the voltage control loop from the EAOUT pin. The PE99153 takes the voltage applied to the ISET pin, subtracts 0.7V (typ) and applies that voltage to the R_{SET} resistor. An internal R_{SET} resistor will be used if the RSEL pin is grounded or an external R_{SET} resistor connected to the RSET pin is used if the RSEL pin is tied high. The current flowing through the R_{SET} resistor is then used as a scaled current reference for the inductor current threshold comparison. The scaling ratio is defined as G_{IREF} in Table 2.

Over current protection is achieved by limiting the maximum voltage applied to the internal or external R_{SET} resistor to the $V_{MAXRSET}$ value listed in Table 2. Thus, the current limit can be adjusted by selection of the external R_{SET} resistor. This flexibility allows characterization and testing to a high current in the lab while still limiting the current to lower level in the application.

Voltage Control Loop

The output voltage is achieved by controlling the ISET pin. The PE99153 contains an amplifier with both of the positive and negative input terminals, EAINP and EAINM respectively, and the output terminal EAOUT all pinned out to package pins. This allows for flexible configurations of the voltage reference, error amplifier, feedback networks and the current mode control loop. In normal configuration the error amp senses the output voltage, V_{OUT} , through a resistor divider that produces a 1.000V division at the target V_{OUT} . It compares that feedback voltage to the 1.000V reference and increases the voltage applied to the ISET pin when the output voltage is low and decreases the voltage applied to the ISET pin when the output voltage is high. Loop compensation is required to attenuate the frequency content at and above the switching frequency and to achieve the desired phase margin in the voltage control loop. See the Design Guide for instructions on designing the compensation network.

Accurate Voltage Reference

The PE99153 contains an accurate 1.000V reference which is used to drive an accurate output voltage. The 1.000V reference is trimmed at the factory to within $\pm 1\%$ of 1.000V at 25 °C.

Soft start

The soft start circuit uses the voltage on the SSCAP pin to limit (pull down) the external VREF pin. This allows the designer to limit the output voltage ramp rate. Voltage tracking is specified on the VREF pin for applications that require an external tracking capability.

The SSCAP pin is internally connected to a 16 pF (typ) cap to ground and to a 3V internal rail through a 1.2 M Ω (typ) resistor. When the SDb pin is low, the SSCAP pin is pulled to ground by a 12 k Ω (typ) resistor. When the shutdown signal is released the pull down switch is released and the voltage on the SSCAP pin begins to ramp up toward 3V. The ramp rate can be increased by tying the SSCAP pin to the 5V input rail through an external resistor. The pin is 5V capable. The ramp rate can also be slowed by connecting the SSCAP pin to ground through a supplemental capacitor.

Under Voltage Lockout

An internal under voltage lockout feature prevents the PE99153 from powering up before input voltage rises above the UVLO threshold of 4.2V (typ). 400 mV (typ) of hysteresis is built-in to prevent false-triggering of the UVLO circuit. The under voltage lockout must be cleared and the SDb pin must be released before the part will be enabled.

Power Good Flag

The PGOOD pin is an open drain output that can be used to sense when the output voltage of the converter has converged to within 10% (typ) of its final value. This pin can also be used to provide limited power sequencing when cascaded with the SDb pin of another PE99153 part.

Internal circuitry senses when the voltage at the EAINM pin has reached to within 10% (typ) of an internal 1.000V reference voltage. When this happens, an internal counter begins counting reference clock cycles and continues counting as long as this condition remains true. When the counter has reached 64, the circuit will assert PGOOD.

When EAINM exits the PGOOD window, there is a 30 mV (typ) hysteresis to prevent chatter when entering or exiting the window. If during the count, the EAINM pin exits the PGOOD threshold, the counter is reset, PGOOD is not asserted and the count will begin again when EAINM re-enters the PGOOD window.

When exiting the PGOOD state, once EAINM is outside of the PGOOD threshold window, an internal counter begins counting and will de-assert PGOOD when it counts 64 reference clock cycles. If during the count, the EAINM pin re-enters the PGOOD threshold, the counter is reset, PGOOD is not de-asserted and the count will begin again when EAINM exits the PGOOD window.

Synchronous (External Reference) or Asynchronous (Internal Reference) Switching Frequency

The PE99153 contains an internal oscillator capable of operating at 1 MHz when the SYNC pin is tied to V_{IN} or left open or at 500 kHz when the SYNC pin is tied to ground. This reference clock is used in the current mode control loop to time the rising edge of the OUT pin and as a global internal clock reference. When the SYNC pin is actively clocked at a rate of 100 kHz to 5 MHz, the internal oscillator uses the clocked sync pulse train as the global internal clock reference.

Whether operating synchronously or asynchronously, the open drain SYNCOb pin contains the inverted internal clock reference. This inverted clock signal can be used to aid in the design of polyphase ($n=2$) power supplies.

DESIGN GUIDE

Setting the Output Voltage

The PE99153 can be configured to output a DC voltage from +1.0V to +3.6V. The user can set the output voltage by selecting the external feedback resistors R_{fb1} and R_{fb2} . The feedback resistors divide down the output voltage to be compared to a +1.000V reference voltage. The error amplifier uses this comparison to determine the amount of current to send to the load.

To set the output voltage, a resistor divider must be selected that will produce at +1.000V DC voltage at the EAINM pin when V_{OUT} has reached the target output voltage.

Figure 6. Output Voltage Selection

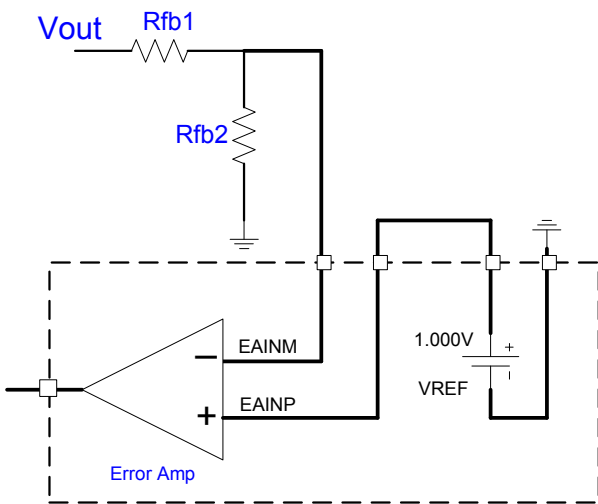

$$V_{OUT} = (R_{fb1} + R_{fb2}) / R_{fb2} = 1 + R_{fb1} / R_{fb2}, \text{ and}$$

$$R_{fb1} = R_{fb2} * (V_{OUT} - 1), +1V < V_{OUT} \leq +3.6V$$

The PE99153 reference design uses a value of 10 kΩ for R_{fb2} .

Example:

Desired $V_{OUT} = +2.5V$

$R_{fb2} = 10 \text{ k}\Omega$

$R_{fb1} = 10 \text{ k}\Omega * (+2.5V - 1) = 15 \text{ k}\Omega$

* For a desired output voltage of 1V, R_{fb1} can be replaced with a 0Ω resistor and R_{fb2} not installed. This is equivalent to directly connecting V_{OUT} to EAINM.

Output Inductor Selection

The output Inductor serves as the main energy storage element in a switching regulator. It is perhaps the most critical component influencing the performance of the buck regulator. It impacts many aspects of the power supply system performance, including power supply bandwidth, output voltage ripple and ripple spectrum, and switching, conduction, and core losses. Additionally, specific aspects

of the buck regulator itself place requirements on the range of allowable Inductor values. These aspects include the internal current detector sensitivity, the slope compensation ramp dynamic range, and the current limitations of the part. The selection of the Inductor is also a function of the specifics of the application including input voltage, output voltage, load current range, switching frequency, PCB area, efficiency targets, power supply bandwidth, and ripple requirements, to name a few.

Many performance requirements and other component selections place restrictions on the Inductor selection. However, since the Inductor selection plays a central role in the performance of the power supply, its selection needs to be made early in the design process. Therefore, as a starting point, the Inductor needs to be initially selected based on a few rough calculations and selection can be refined iteratively as more system requirements are introduced.

The voltage across the Inductor is $V_L = L \times \Delta IL / \Delta t$, where ΔIL is defined to be the Inductor peak-to-peak current ripple. The ripple current is the change in the Inductor current during each switching cycle. For the PE99153, the lower limit of ΔIL is set by the current threshold comparator sensitivity, while the upper limit of ΔIL is set by the current mode compensation dynamic range.

Given the output voltage, switching frequency, input voltage and the minimum ΔIL required by the part, the Inductance can be calculated as:

$$L = V_L \times \Delta t / \Delta IL$$

$$L = V_{OUT} / (F_{SW} \times \Delta IL) \times (1 - D), \text{ where}$$

Duty cycle = $D = V_{OUT} / V_{IN}$

Switching frequency = F_{SW}

Duration of Inductor voltage = $\Delta t = D / F_{SW}$

As the output switches pull the OUT pin alternately to V_{IN} and to GND, the inductor peak to peak current ripple (triangular current waveform magnitude) is expressed as:

$$\Delta IL = V_{OUT} / (L \times F_{SW}) * (1 - D)$$

Example:

$V_{IN} = +5.0V$

$V_{OUT} = +2.5V$

$F_{SW} = 1 \text{ MHz}$

$\Delta IL = 0.5A$

$L = V_{OUT} / (F_{SW} \times \Delta IL) \times (1 - D)$

$L = (+2.5 / (1 \text{ MHz} \times 0.5)) * [(1 - (+2.5 / +5.0))] = 2.5 \mu H$

The Inductor self resonant frequency (SRF) should be selected to be at least 10x higher than the switching frequency F_{SW} . Meeting this requirement will ensure stability, reduce output ripple and improve efficiency.

The DC resistance of the Inductor will primarily impact efficiency. For optimal efficiency, the inductor DC resistance should be selected to be on the order of magnitude of the R_{ON} of the high side switch and low side switch. Calculation of the efficiency impact will be discussed in the efficiency section of the Design Guide. A smaller DC resistance will improve efficiency but will likely impact PCB area, a subject not addressed in this Design Guide.

Output Capacitor Selection

The output Capacitor works in tandem with the output Inductor to filter the Inductor ripple current and to source and sink current to meet the load demand during a load step. The output Capacitor is implemented as a network of parallel capacitors covering low, mid, and high frequency operation. The capacitor Equivalent Series Resistance (ESR) and Equivalent Series Inductance (ESL) have a direct impact on the output voltage ripple, output voltage droop under transient loading, and loop stability. Ceramic X7R dielectric capacitors are recommended for their thermal and electrical properties, along with their size and cost.

Figure 7. Output Capacitor Selection

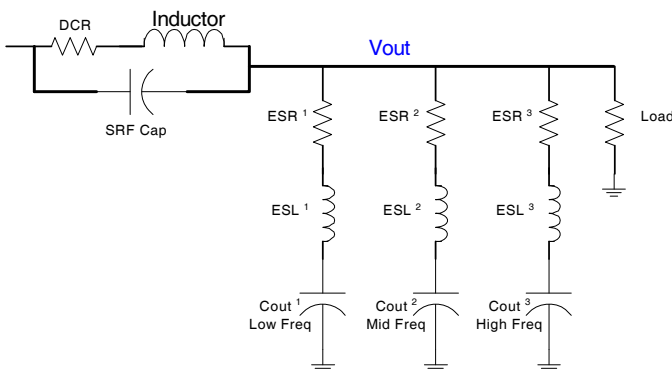

The output voltage droop should be empirically determined to satisfy the application load step response requirements. During a transient step in the load current, the output voltage will initially experience an IR drop of $\Delta I_{LOAD} \times ESR$. If the output capacitor bank is too large, the IR drop is minimized but the V_{OUT} recovery time is longer. If the output capacitor bank is too small, the IR drop is increased but the V_{OUT} recovery time is shorter.

The output voltage ripple should be chosen to meet the application requirements and tradeoff with the physical size of the capacitor bank. The output voltage ripple waveform can be estimated by taking the inverse Fourier transform of the product of the Fourier transform of the input signal and the frequency domain transfer function of the network in Figure 7. (The input to the transfer function

can be approximated as an ideal square wave with period of F_{SW} , amplitude of V_{IN} and a duty ratio of V_{OUT} / V_{IN} .)

If a SPICE simulation tool is available, the above estimation can be done by placing the above mentioned square wave at the input of the filter network and solving for the output waveform.

Additionally, the total output capacitance and load resistance set the dominant pole of the voltage mode control loop. Voltage mode loop stability is described in the "Voltage Control Loop Compensation Network Design" section.

In addition to playing a role in stability and output voltage ripple, the output capacitor bank must be able to absorb the inductor ripple current. The inductor peak-to-peak ripple current, calculated as ΔI_L in the inductor selection section, will be absorbed by the capacitor bank. Note that the RMS current through the output cap can be calculated as $\Delta I_L / \sqrt{3}$ since inductor ripple current waveform is triangular. The frequency range of capacitors absorbing the ripple current must be rated to handle this ripple current.

The PE99153 reference design features three output capacitors (Cout1, Cout2, and Cout3) that have been chosen to blend total capacitance, ESR, and ESL to meet the ripple, droop, and stability requirements over frequency.

Input Capacitor Selection

The input capacitor network sources the trapezoidal current wave through the source terminal of the high side switch. Therefore, the RMS current handling and maximum voltage rating are the main considerations in selecting the input capacitors.

Neglecting the small (as compared with the load) Inductor ripple current and assuming that the input capacitor sources all of the ripple current, the RMS current through the input capacitor can be calculated as

$$I_{RMS-CIN} = I_{LOAD(max)} \times \sqrt{[D \times (1-D)]}$$

In addition to sourcing the trapezoidal current wave through the high side switch, the input bypass capacitors absorb the high frequency components of the switching power supply preventing conducted EMI from reaching the up stream supply. As such, the input bypass capacitor SRF should be on the order of 10x higher than the switching frequency of the buck regulator. Additional high frequency capacitors may be added to further attenuate the high frequency conducted EMI.

Like the output capacitors, Ceramic X7R dielectric capacitors are recommended with the added benefit that the X7R capacitors have very low DC voltage de-rating.

Efficiency Estimation and Improvement

The efficiency of a switch mode power supply can be estimated by identifying and estimating all sources of loss in the power supply system. These loss terms include switching losses, resistive losses, losses incurred on chip and losses associated with external passive components. External passive losses occur primarily in the output inductor, the output capacitor and the input capacitor. Internal losses at high current are dominated by the high and low side switch resistance. At low current, internal losses are dominated by quiescent bias current and switching related losses.

The PE99153 Design Guide provides a simple tool for estimating loss. Losses are parameterized across input voltage, output voltage and switching frequency to provide accurate estimates of the performance of the part under a variety of conditions.

The following sections give the mathematical expressions of six main loss terms calculated in the design guide spreadsheet.

Input Capacitor

The loss in the input capacitor can be calculated by using the estimate of the RMS capacitor current calculated in the input capacitor selection section. Given that:

$$I_{RMS-CIN} = I_{LOAD(max)} \times \sqrt{[D \times (1-D)]}$$

Power lost in the input capacitor can be calculated as:

$$P_{LOSS-CIN} = I_{RMS-CIN}^2 \times R_{CIN-ESR}$$

Output Capacitor

The RMS current through the output capacitor in steady state was calculated in the output capacitor selection section as $\Delta IL / \sqrt{3}$. Power loss in the output capacitor is then calculated as:

$$P_{LOSS-COUT} = (\Delta IL^2 / 3) \times R_{COUT-ESR}$$

Note that $R_{COUT-ESR}$ is the ESR of the frequency range of capacitors absorbing the ripple current.

Inductor

The inductor RMS current is given by:

$$I_{LRMS} = I_{LOAD} - \Delta IL / 2 + \Delta IL / \sqrt{3}$$

Power lost in the DC resistance of the inductor is then given as:

$$P_{LOSS-LOUT-DCR} = I_{LRMS}^2 \times R_{LOUT-DCR}$$

High Side Switch Loss

During the time the HSS is on, it is supporting the load current plus the inductor ripple current. RMS current through the HSS, when it is on, is given by:

$$I_{RMS-HSS} = I_{LOAD} - \Delta IL / 2 + \Delta IL / \sqrt{3}$$

$$P_{LOSS-HSS} = I_{RMS-HSS}^2 \times R_{ON-HSS} \times D$$

Where the extra factor of $D = V_{OUT} / V_{IN}$ is the duty ratio and is included because power is only dissipated in the HSS when it is on.

Low Side Switch Loss

During the time the LSS is on, it is supporting the load current plus the inductor ripple current. RMS current through the LSS, when it is on, is given by:

$$I_{RMS-LSS} = I_{LOAD} - \Delta IL / 2 + \Delta IL / \sqrt{3}$$

$$P_{LOSS-LSS} = I_{RMS-LSS}^2 \times R_{ON-LSS} \times (1 - D)$$

Where the extra factor of $1 - D = (V_{IN} - V_{OUT}) / V_{IN}$ is the duty ratio of the LSS and is included because power is only dissipated in the LSS when it is on.

Other Internal Loss

A complete list of internal losses in the PE99153 regulator is estimated and available in the PE99153 design guide spreadsheet available online. The internal losses are parameterized across input voltage, output voltage and switching frequency to provide accurate estimates of the performance under a variety of conditions.

Setting the Current Limit

When the RSEL pin is grounded, the PE99153 uses an internal current limiting resistor that will limit the output current to a value of $I_{LIMXINT}$ listed in *Table 2* of the datasheet. See *Figure 8* for a visual description of the various current limits. The part can be programmed to use an alternate current limit by tying the RSEL pin to V_{IN} . In this mode, the PE99153 can be programmed to various output current limits through the selection of a resistor connecting the RSET pin to ground.

Figure 8. PE99153 DIE Current Limits

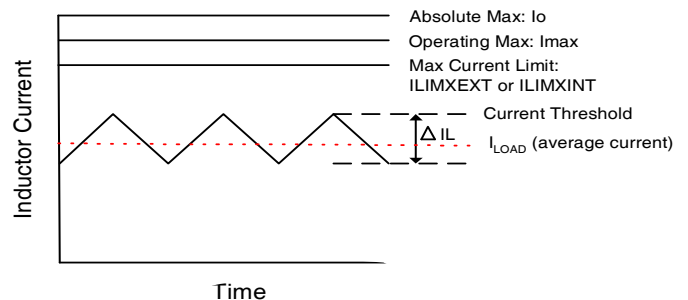

In external RSET mode, the PE99153 senses the voltage applied to the ISET pin (from the EAOUT pin, through the compensation network) and subtracts the resulting reference current offset. This subtraction is then applied to the RSET pin. This voltage at the RSET pin draws current through the RSET resistor. This current is used as a current threshold to set the peak inductor current in the current mode control loop. The maximum voltage at the RSET pin is limited to VMAXRSET in Table 2 independent of the voltage applied to the ISET pin. Since this voltage is limited, the maximum reference current through the RSET resistor is limited to VMAXRSET / RSET.

After a reference current is generated through the RSET pin, the current is multiplied by the GIREF parameter listed in Table 2. Thus the peak current allowed by the current mode control loop will be limited to:

$$I_{LIMIT} = G_{IREF} \times (V_{MAXRSET}/R_{SET}) - \Delta I_{COMP}$$

Solving for RSET

$$R_{SET} = (G_{IREF} \times V_{MAXRSET}) / (I_{LIMIT} + \Delta I_{COMP})$$

Slope Compensation Ramp Selection

While providing improved bandwidth and inherent current limiting, all current mode control switching regulators require slope compensation to ensure stability across all applications conditions. The PE99153 provides adjustable slope compensation to allow the designer to optimize transient response and stability requirements.

During steady state, a compensation ramp is created at the ICOMP pin. The RC ramp is created by the external RCOMP resistor and an internal capacitor. The ramp is reset any time the low side switch is on by means of a reset switch. The voltage at the ICOMP pin is multiplied by the Giref parameter in Table 2 and is subtracted from the reference current of the current threshold comparator.

Before calculating the required slope compensation to ensure stability, a related slope is defined. In steady state, when the low side switch is on, the inductor current ramps down at a rate of M2. M2 is given as VOUT / L, where L is the inductance of the output inductor.

The minimum slope compensation ramp current, Ma required for mathematical steady state stability under all conditions is one half of M2. That is:

$$M_a \geq M_2 / 2$$

To provide margin to the minimum, a compensation slope equal to M2 is recommended:

$$M_a = M_2$$

Given the required compensation current (Ma), the voltage ramp rate at the ICOMP pin can be calculated by dividing by the GICOMP parameter in Table 2.

$$\Delta V_{ICOMP} = \Delta I_{COMP} / G_{ICOMP}, \text{ where}$$

$$\Delta I_{COMP} = (\Delta I_L \times \Delta t_{on} \times M_a / M_2) / \Delta t_{off} \text{ and } \Delta V_{ICOMP} = (0.95 \times V_{OUT}^2) / (C_{ICOMP} \times R_{COMP} \times F_{SW} \times V_{IN})$$

Next, substituting for ΔL from the output inductor equation and given the required voltage ramp rate and the internal capacitance connected to the ICOMP pin, CCOMP in Table 2, the resistor connected from VOUT to the ICOMP pin can be calculated:

$$R_{COMP} = (0.95 \times G_{ICOMP} \times L) / (C_{ICOMP} \times M_a / M_2),$$

where 95% of VOUT is used to achieve a linear approximation of the average current through CCOMP, assuming the voltage drop over 1 cycle varies from 100 to 90%.

Figure 9. PE99153 DIE Slope Compensation

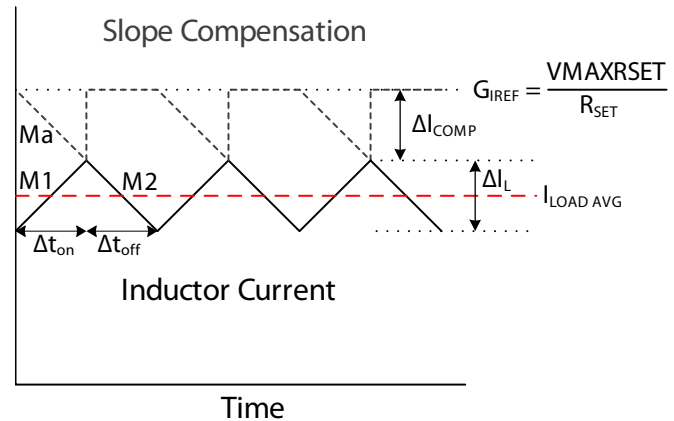

Voltage Control Loop Compensation Network Design

The PE99153 contains a current mode control loop and a voltage mode control loop as shown in Figure 10.

The current mode control loop, to first order, controls average inductor current and so behaves as a current source. Conceptually, the current mode control loop can be replaced with a voltage controlled current source.

External to the compensation network, the resulting network contains one pole in the voltage control loop. This pole is created by the parallel combination of Cout and the Load Resistance and is located at: $1 / (2\pi R_{LOAD} C_{OUT})$

One requirement of the voltage control loop stability analysis and design is to maintain significant attenuation at the switching frequency of the converter. If this requirement is not met, the switching noise can enter the control loop and loop stability will be lost. To ensure sufficient attenuation at the switching frequency, a unity gain cross over frequency one decade below the switching frequency is recommended. Additional margin may be desired depending on the application requirements.

The pole created by the load and the output capacitor is dependent on load current. The load current can vary, likely all the way down to zero load current. When this happens the output pole frequency falls arbitrarily low. It is clear that this highly variable pole will not be sufficient to set a dominant pole in the loop to ensure stability.

The recommended compensation technique is a combined pole-zero compensation network. The zero is set to cancel the variable load pole at minimum load so that the load pole does not affect phase margin of the system when the pole location is at it's minimum value, possibly even in the bandwidth of the control loop. With the load pole canceled by the additional zero, the added pole in the compensation network acts as a stable dominant pole. This dominant

pole location can be selected for both attenuation of the F_{SW} switching noise and for the required phase margin and loop bandwidth.

With this compensation technique, the zero location is calculated as $1 / (2\pi R_C C_C)$. R_C and C_C should be selected to cancel the load pole at minimum load.

If the compensation network resistor is selected to be much less than the output impedance R_{OUT} of the error operational transconductance amplifier (OTA), the dominant pole location can then be approximated as $1 / (2\pi R_{OUT} C_C)$. At first glance this may seem to make the dominant pole location dependent on the loosely controlled error amp output impedance. However, as the error amp output impedance drops, the DC gain of the system and the dominant pole location reduce together. The result is that the unity gain cross over frequency (set by the dominant pole) is independent of OTA output impedance variation over process and temperature.

A compensation network design spreadsheet is available in the PE9915x Design Tool.

Figure 10. PE99153 Control Loops

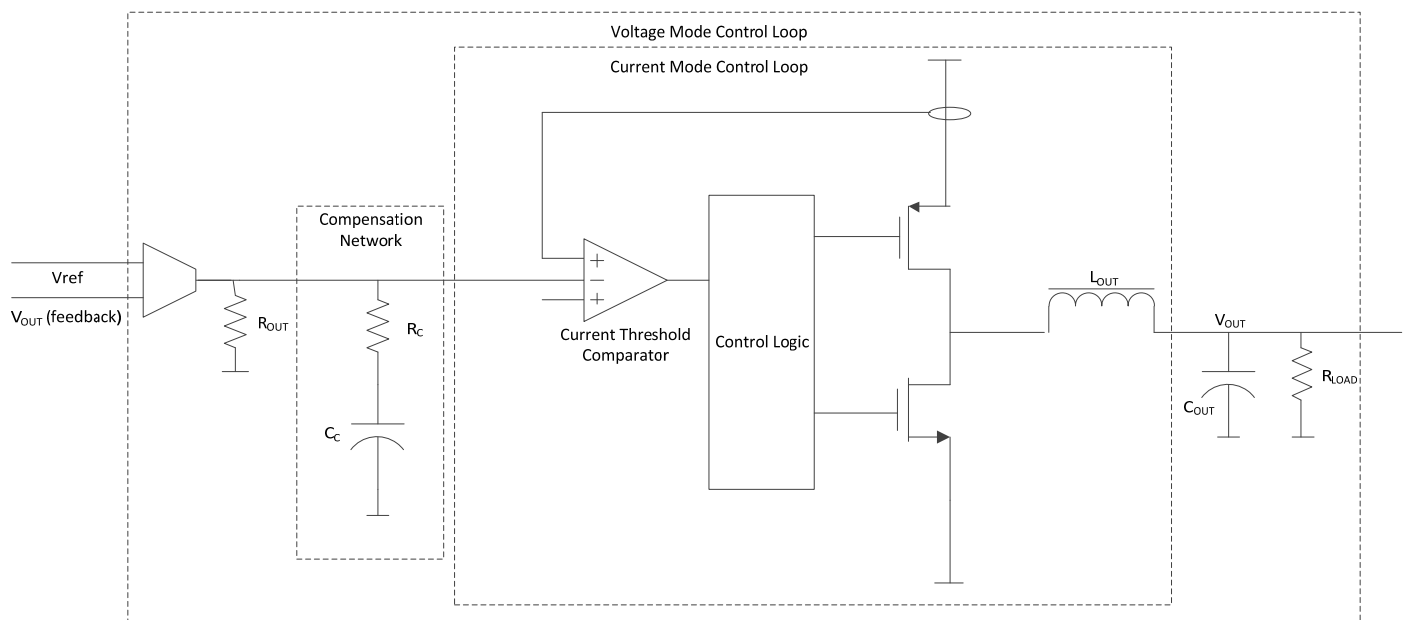
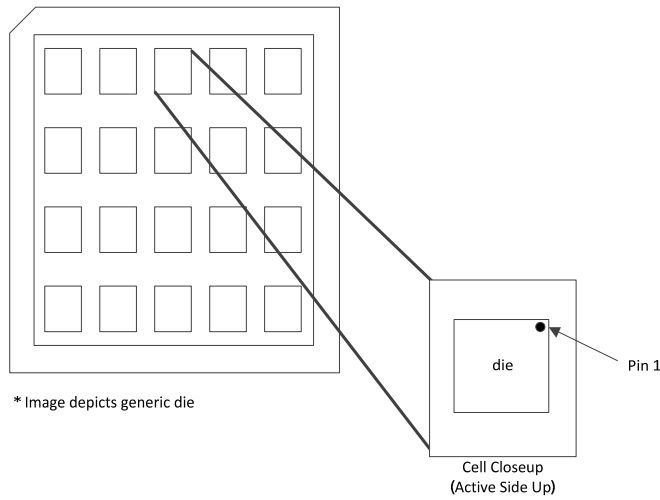

Figure 11. Waffle Pack Information



* Image depicts generic die

Note: * Dice will be oriented in the same direction in and within all waffle packs. Unless otherwise stated, dice will be oriented such that the top left corner of the dice will be in-line with the “notched” corner of the die plate base and cover. If a different orientation is required, it will be shown on the traveler or purchase order and process instructions. In all cases, the die base cover label will be affixed on the die base cover such that the top of the label indicates the top of the dice within the waffle pack.

Table 7. Mechanical Specification

Parameter	Minimum	Typical	Maximum	Unit
Die Size, Singulated (x,y)	5.07 x 3.33	5.09 x 3.35	5.14 x 3.40	mm
Wafer Thickness	180	200	220	µm
Wafer Size		150		mm

Table 8. Ordering Information

Order Code	Description	Package	Shipping Method
99153X-98 ¹	Engineering sample die with bonding X (X = A–H) ²	Die	Waffle pack (5 units max)
99153X-99	Flight die with bonding X (X = A–H) ²	Die	49 units / Waffle pack
99153-00	Evaluation kit		1 / Box

Notes: 1. The 99153X-98 die are ES (engineering sample) units intended as initial evaluation devices for customers of the 99153X-99 flight die. The 99153X-98 ES die provide the same electrical functionality and performance as the 99153X-99 flight die, but is processed to a non-compliant flow (e.g. no QCI coverage or element evaluation data). These die are obtained from non-qualified wafers so are not suitable for qualification, production, radiation testing or flight use.
2. The bonding designator X (X = A through H) will be indicated on the Certificate of Compliance (CoC) provided with the shipment, along with the specific applicable bonding diagram.

Sales Contact and Information

Contact Information:
e2v - <http://www.e2v-us.com> - inquiries@e2v-us.com

Advance Information: The product is in a formative or design stage. The datasheet contains design target specifications for product development. Specifications and features may change in any manner without notice.
Preliminary Specification: The datasheet contains preliminary data. Additional data may be added at a later date. Peregrine reserves the right to change specifications at any time without notice in order to supply the best possible product.
Product Specification: The datasheet contains final data. In the event Peregrine decides to change the specifications, Peregrine will notify customers of the intended changes by issuing a CNF (Customer Notification Form).

The information in this datasheet is believed to be reliable. However, Peregrine assumes no liability for the use of this information. Use shall be entirely at the user's own risk.

No patent rights or licenses to any circuits described in this datasheet are implied or granted to any third party. Peregrine's products are not designed or intended for use in devices or systems intended for surgical implant, or in other applications intended to support or sustain life, or in any application in which the failure of the Peregrine product could create a situation in which personal injury or death might occur. Peregrine assumes no liability for damages, including consequential or incidental damages, arising out of the use of its products in such applications.

The Peregrine name, logo, UltraCMOS and UTSi are registered trademarks and HaRP, MultiSwitch and DuNE are trademarks of Peregrine Semiconductor Corp. Peregrine products are protected under one or more of the following U.S. Patents: <http://patents.psemi.com>.