



SICOFI[®] 4- μ C
Four Channel Codec
Filter with PCM and
Microcontroller Interface

PEB 2466 Version 2.2

PEF 2466 Version 2.2

Wired
Communications



Never stop thinking.

Edition 2001-02-20

**Published by Infineon Technologies AG,
St.-Martin-Strasse 53,
D-81541 München, Germany**

**© Infineon Technologies AG 2001.
All Rights Reserved.**

Attention please!

The information herein is given to describe certain components and shall not be considered as warranted characteristics.

Terms of delivery and rights to technical change reserved.

We hereby disclaim any and all warranties, including but not limited to warranties of non-infringement, regarding circuits, descriptions and charts stated herein.

Infineon Technologies is an approved CECC manufacturer.

Information

For further information on technology, delivery terms and conditions and prices please contact your nearest Infineon Technologies Office in Germany or our Infineon Technologies Representatives worldwide (see address list).

Warnings

Due to technical requirements components may contain dangerous substances. For information on the types in question please contact your nearest Infineon Technologies Office.

Infineon Technologies Components may only be used in life-support devices or systems with the express written approval of Infineon Technologies, if a failure of such components can reasonably be expected to cause the failure of that life-support device or system, or to affect the safety or effectiveness of that device or system. Life support devices or systems are intended to be implanted in the human body, or to support and/or maintain and sustain and/or protect human life. If they fail, it is reasonable to assume that the health of the user or other persons may be endangered.

SICOFI[®]4- μ C

Four Channel Codec Filter with PCM and Microcontroller Interface

PEB 2466 Version 2.2

PEF 2466 Version 2.2

Wired
Communications



Never stop thinking.

PEB 2466

PEF 2466

Revision History: 2001-02-20

DS 1

Previous Version: --

Page	Subjects (major changes since last revision)
------	--

For questions on technology, delivery and prices please contact the Infineon Technologies Offices in Germany or the Infineon Technologies Companies and Representatives worldwide: see our webpage at <http://www.infineon.com>

ABM[®], AOP[®], ARCOFI[®], ARCOFI[®]-BA, ARCOFI[®]-SP, DigiTape[®], EPIC[®]-1, EPIC[®]-S, ELIC[®], FALC[®]54, FALC[®]56, FALC[®]-E1, FALC[®]-LH, IDEC[®], IOM[®], IOM[®]-1, IOM[®]-2, IPAT[®]-2, ISAC[®]-P, ISAC[®]-S, ISAC[®]-S TE, ISAC[®]-P TE, ITAC[®], IWE[®], MUSAC[®]-A, OCTAT[®]-P, QUAT[®]-S, SICAT[®], SICOFI[®], SICOFI[®]-2, SICOFI[®]-4, SICOFI[®]-4 μ C, SLICOFI[®] are registered trademarks of Infineon Technologies AG.

ACE[™], ASM[™], ASP[™], POTSWIRE[™], QuadFALC[™], SCOUT[™] are trademarks of Infineon Technologies AG.

Table of Contents		Page
	Preface	1
1	Overview	2
1.1	Features	4
1.2	Logic Symbol	5
1.3	Typical Applications	6
2	Functional Description	7
2.1	DSP-based Architecture	7
2.2	Programming and Control	7
2.3	Signal Flow	8
2.4	Functional Blocks	9
3	Operational Description	11
3.1	Operating States	11
4	Interface Description	13
4.1	Analog Interface	13
4.2	PCM Interface	14
4.3	Signaling Interface	14
4.4	Microcontroller Interface	14
5	Application Hints	16
5.1	Typical Applications	16
5.1.1	Analog Linecards for Central Offices and PBXs	16
5.1.2	Small PBX or Key Systems	17
5.1.3	Digital Loop Carrier (DLC) Systems	18
5.1.4	PCM4 Systems	19
5.1.5	Fiber-to-the-Curb (FTTC) Systems	20
5.1.6	Radio-in-the-Loop (RITL) Systems	21
5.2	Support Tools	22
5.2.1	QSICOS Software	22
5.2.2	EASY 2466 Tool Package	25
6	Glossary	26
	Index	27

List of Figures	Page
Figure 1	Traditional Linecard Layout 2
Figure 2	Linecard with Digital Filters 2
Figure 3	Four-Channel Linecard with SICOFI [®] 4- μ C Codec. 3
Figure 4	SICOFI [®] 4- μ C Logic Symbol. 5
Figure 5	SICOFI [®] 4- μ C Block Diagram. 8
Figure 6	SICOFI [®] 4- μ C Simplified Flow Diagram 9
Figure 7	SICOFI [®] 4- μ C Simplified State 11
Figure 8	SICOFI [®] 4- μ C Interfaces 13
Figure 9	Analog Linecard Example for Central Offices and PBXs 16
Figure 10	Small PBX or Key System Example 17
Figure 11	Digital Loop Carrier System Example 18
Figure 12	PCM4 System Example 19
Figure 13	Fiber-to-the-Curb System Example 20
Figure 14	Radio-in-the-Loop System Example 21
Figure 15	Dialogs of the QSICOS Coefficients Software 22
Figure 16	Input Files of QSICOS 23
Figure 17	PSpice Schematic Editor 23
Figure 18	Parameter Settings of the Control File. 24
Figure 19	Dialog for Programming the Evaluation Board. 25

List of Tables

Page

Table 1	SICOFI Family Tree	3
---------	--------------------------	---

Preface

This document summarizes the features of the SICOFI[®]4- μ C four Channel Codec Filter with PCM and Microcontroller Interface for anyone wanting a basic description of the device as an appropriate choice for an extensive range of analog telephony applications. All content applies to both the standard PEB 2466 and the extended temperature range version, PEF 2466, unless specified.

Organization of this Document

This *Product Overview* is organized as follows:

- Chapter 1, Overview
Includes a general description, features list, and logic symbol and identifies typical applications.
- Chapter 2, Functional Description
Summarizes the architecture, programming and control functions, provides a simplified flow diagram, and summarizes the major functional blocks.
- Chapter 3, Operational Description
Summarizes the operating modes and includes a state diagram.
- Chapter 4, Interface Descriptions
Summarizes the four interfaces: Analog, PCM, Signaling, and Microcontroller.
- Chapter 5, Application Hints
Summarizes and illustrates six applications and indicates the support tools available, including QSICOS software and STUT 2466 Development board.
- Appendix
Includes a glossary and an index.

Related Documentation

Additional documentation for the SICOFI[®]4- μ C includes a *Product Brief*, *Hardware Reference Manual*, *Programmer's Reference Manual*, and assorted *Application Notes*.

Documentation is also available for other SICOFI Codec devices including the PSB 2132, PSB 2134, and PEB 2266. Documentation is available by accessing our website: <http://www.infineon.com/sicofi>

1 Overview

The SICOFI[®]4- μ C is a 4-channel PCM codec filter device. It combines an analog A/D and D/A converter with a programmable digital filter architecture in order to allow a flexible, worldwide approach for global analog telephony applications. The programmable 4-channel codec is ideal for use in Central Offices (CO) and Private Branch Exchanges (PBX), access networks, and any multi-channel, digital voice processing, storage, or communications system. The PEB 2466 is available for standard temperature range applications (0 °C to +70 °C); the PEF 2466 is available for extended temperature range applications (-40 °C to +85 °C).

Figure 1 through **Figure 3** depict the evolution from a traditional analog linecard to a SICOFI[®]4- μ C-based solution. **Figure 1** shows a traditional linecard with hardwired discrete filters for impedance matching and hybrid balancing. Discrete filters consume valuable board space and fluctuate over temperature and age. Since transmission requirements vary by country, these analog filters must be adapted for each market.

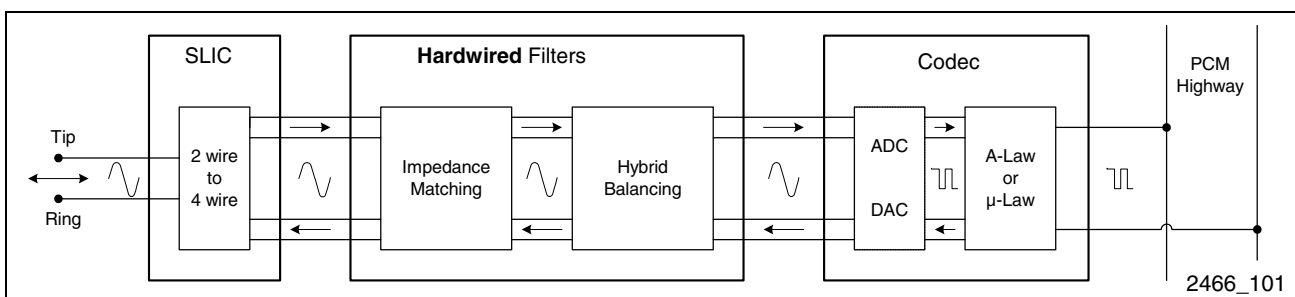

Figure 1 Traditional Linecard Layout

The digital filter solution shown in **Figure 2** offers two significant advantages over the discrete solution: the integrated filter-codec frees up board space and the linecard's transmission characteristics can be accurately programmed and will not drift.

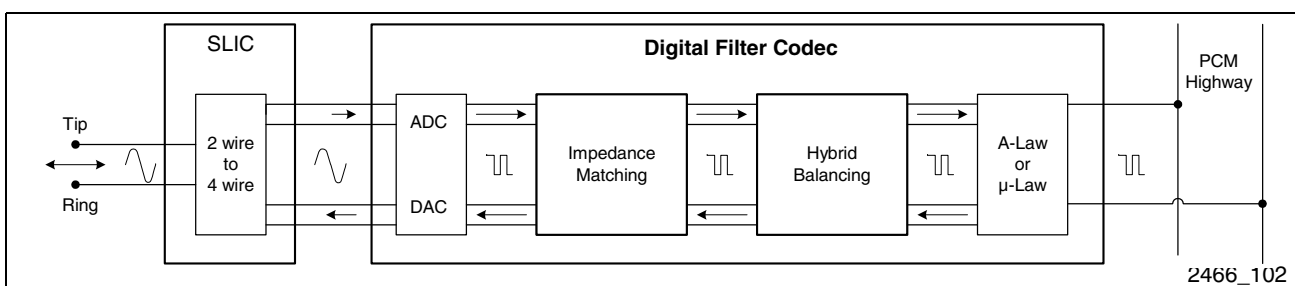

Figure 2 Linecard with Digital Filters

Figure 3 illustrates a 4-channel linecard based on the SICOFI[®]4- μ C. With its advanced mixed-signal CMOS process and a powerful integrated DSP engine, the PEB 2466 combines four filter codecs into a single 4-channel device. Each channel is independently programmable and may be assigned to any time slot of two PCM highways. The SICOFI[®]4- μ C simplifies analog interface design and reduces board space by integrating the critical functions of four subscriber channels into a single device.

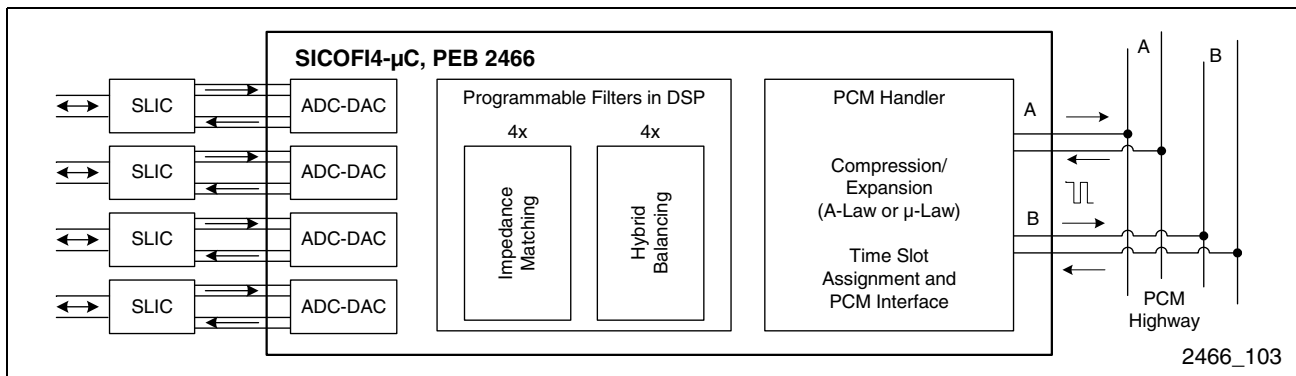

Figure 3 Four-Channel Linecard with SICOFI®4-μC Codec

The 4-channel codec can be used with both integrated and discrete Subscriber Line Interface Circuits (SLIC). The dual PCM Interface facilitates integration into existing switching and transmission systems. The PEB 2466 is software configurable so linecards can be easily adapted to different country specifications. QSICOS Coefficient Calculation and Register Configuration Software simulates specific SLICs and external components, calculates the correct coefficients, and optimizes the behavior of the complete system. Various test features are designed into the SICOFI®4-μC and development boards are available to streamline system design.

Infineon Technologies provides a selection of programmable codecs and SLICs with different levels of integration. The SICOFI devices include 2- or 4-channel versions that can be easily fitted into existing switching and transmission environments. Infineon Technologies also offers advanced codec and SLIC combinations which include programmable DC characteristics, and integrated ringing and supervision functions (MuSLIC, DuSLIC).

Table 1 SICOFI Family Tree

Device		Description
SICOFI2-μC	PEB 2266*	Two Channel Codec Filter with PCM and Microcontroller Interface
SICOFI4-μC	PEB 2466*	Four Channel Codec Filter with PCM and Microcontroller Interface
SICOFI2-TE	PSB 2132	Two Channel Codec Filter for ISDN Terminal and NT Applications
SICOFI4-TE	PSB 2134	Four Channel Codec Filter for ISDN Terminal and NT Applications

* Also extended temperature devices: PEF 2466 and PEF 2266.

Four Channel Codec Filter with PCM and Microcontroller Interface SICOFI®4-μC

PEB 2466
PEF 2466

Version 2.2

CMOS

1.1 Features

- Four-channel single chip codec and filter fulfills the ITU-T Q.552, G.712, and all country-specific requirements
- High analog driving capability (300 Ω, 50 pF) for direct driving of transformers
- Digital Signal Processing (DSP) technique
- Programmable digital filters to adapt transmission behavior, especially for:
 - AC impedance matching
 - Transhybrid balancing
 - Frequency response
 - Gain
 - A/μ-Law compression and expansion
- High performance ADC and DAC for excellent linearity and dynamic gain
- Programmable Analog Interface to electronic SLICs or transformer solutions
- Seven SLIC-signaling I/O pins per channel with programmable debouncing
- Two PCM Highways accessible by on-chip PCM Interface with Programmable time slot assignment and variable data rates from 128 kbit/s to 8 Mbit/s
- Easy to use 4-pin Serial Microcontroller Interface (SPI compatible) for read/write access
- Single supply voltage (5 V)
- Advanced low-power mixed-signal CMOS technology
- Two programmable tone generators per channel (DTMF possible)
- Level metering function for system tests and for analog input signal testing
- Advanced on-chip functions for device and system diagnostics and manufacturing test
 - Five digital loops
 - Four analog loops
- Support tools include:
 - Hardware development board —STUT 2466
 - QSICOS Coefficient Calculation and Register Configuration Software
- Standard P-MQFP-64 package

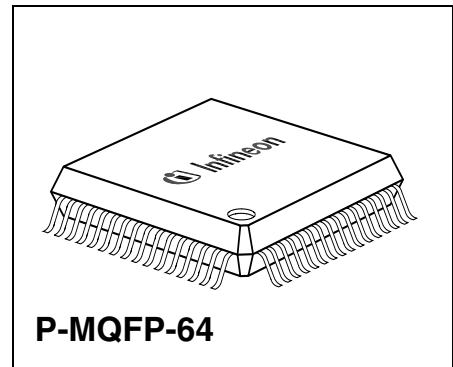

Type	Package
PEB 2466 Version 2.2	P-MQFP-64
PEF 2466 Version 2.2	P-MQFP-64

1.2 Logic Symbol

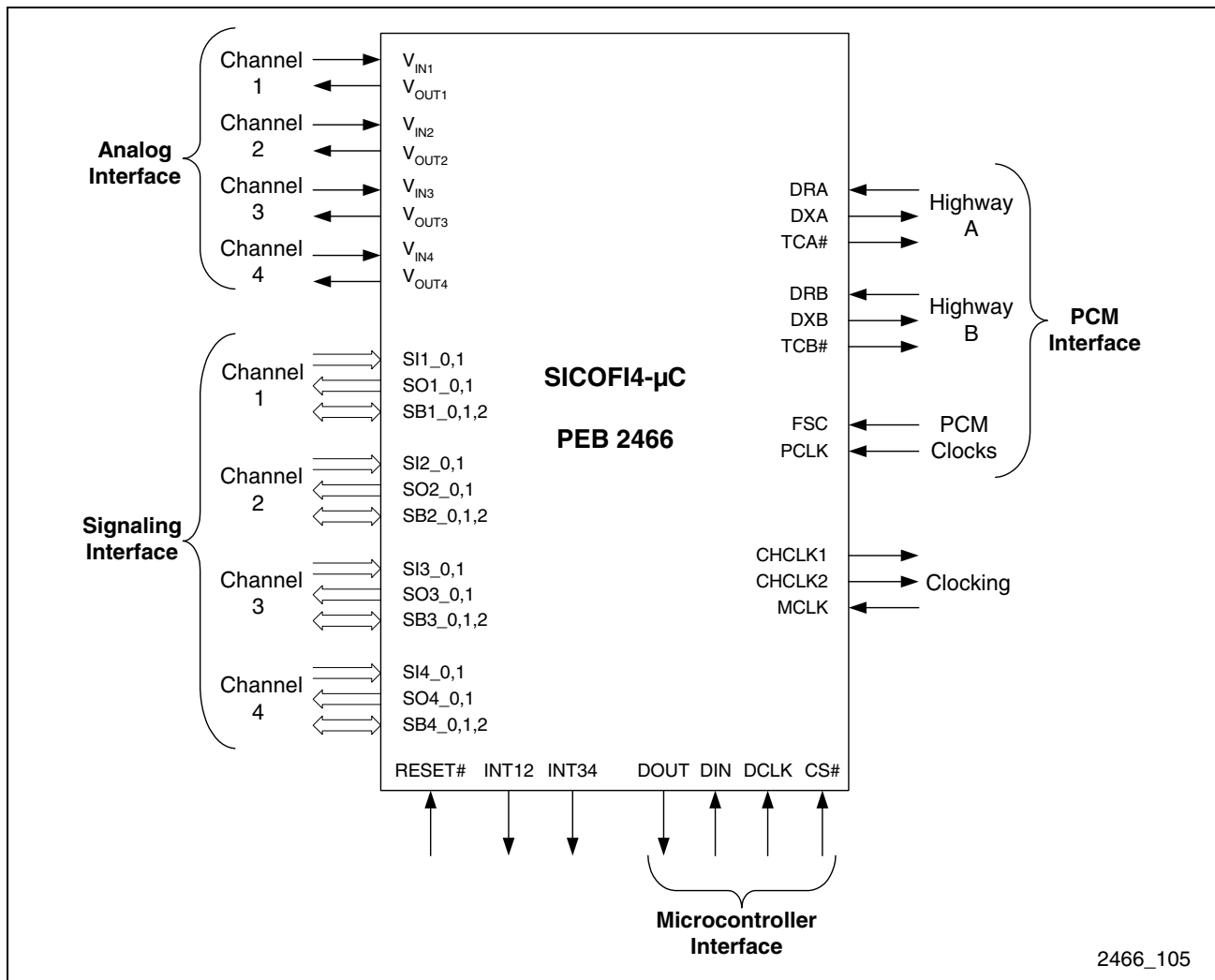

Figure 4 SICOFI[®]4-μC Logic Symbol

Figure 4 depicts the signals and interfaces available in the SICOFI[®]4-μC. The Analog Interface in the SICOFI[®]4-μC has one input pin and one output pin per channel. The Signaling Interface has a total of 28 pins: each channel has two digital inputs, two digital outputs, and three configurable digital inputs/outputs. Two interrupt outputs are available to indicate changes on the signaling inputs. The PCM Interface allows direct connection to two PCM Highways, A and B, each with data transmit and data receive, as well as a buffer control signal. Two clock inputs, for frame and bit synchronization, also apply to the PCM Interface. The Serial Microcontroller Interface consists of four signals: one serial input, one serial output, clock supply, and chip select. The SICOFI[®]4-μC also includes one general reset pin, one master clock input, and two programmable clock outputs. For details, see **Chapter 4** "Interface Description" on page 13.

1.3 Typical Applications

Many applications will benefit from the versatility of the SICOFI[®]4- μ C codec and filter. Product reliability and manufacturability are enhanced by the high level of integration and by fabrication in low-power mixed-signal CMOS technology. The single 5 V supply voltage simplifies system power supply requirements. The inherent flexibility enables several products to be developed around one basic architecture, with the benefit of potentially significant savings in time to market, inventory costs, and support administration. The following list represents some of the typical applications for which the SICOFI[®]4- μ C codec was designed.

- Analog linecards for Central Offices and PBXs,
- Small PBX or Key Systems,
- Digital Loop Carrier (DLC) Systems,
- Digital Added Main Line (DAML) and PCM[®] x Systems,
- Fiber-to-the-Curb (FTTC) Systems,
- Radio-in-the-Loop (RITL) Systems and
- any multichannel, digital voice processing, storage, or communication applications.

Refer to **Chapter 5 "Application Hints"** on page 16 for more information.

2 Functional Description

The telephone subscriber loop is a bi-directional two-wire line. The Subscriber Line Interface Circuit (SLIC) on the network side converts the two-wire interface to a four-wire interface with separate receive and transmit signals. The SLIC can be either a transformer or an electronic circuit with operational amplifiers. It has to have a defined input impedance towards the subscriber line for maximum signal power transfer and return loss. The requirements for the input impedance vary from country to country and demand impedance matching to the different environments. Country-specific adaptations are also required for the transhybrid loss, which is a loss between the transmit and the receive ports of the two-wire to four-wire hybrid.

2.1 DSP-based Architecture

The impedance matching and transhybrid balancing functions are performed by loop filters between the transmit and the receive path. The filter characteristics must be adjusted according to the local requirements of each market. In the analog domain, filters must be optimized in hardware; this is generally both tedious and time-consuming. This is not so when the DSP-based SICOFI[®]4- μ C four-channel codec is used. Its integrated signal processor implements the impedance matching and transhybrid balancing functions as digital, programmable filters. It also performs frequency response corrections and level adjustments to enable the design of a truly universal and internationally applicable telephone linecard. Transmission characteristics and frequency behavior are enhanced by the accuracy of the digital filters, which do not fluctuate over temperature or with age.

QSICOS Coefficient Calculation and Register Configuration Software simulates specific SLICs and external components. QSICOS calculates the correct coefficients and optimizes the behavior of the complete system in accordance with country-specific requirements. As an additional benefit, the DSP-based architecture of the SICOFI[®]4- μ C also provides two tone generators (DTMF is supported) and level metering functions.

2.2 Programming and Control

A very simple Microcontroller Interface is used to program the SICOFI[®]4- μ C functions. The same port provides access to 28 general purpose I/O pins of the Signaling Interface. This allows efficient and convenient monitoring and control of other linecard functions, such as on-/off-hook detection, ground-key detection, switching of ringing signals and test relays. The Serial Microcontroller Interface provides a programming and control interface and is generic and non-proprietary for use with any microcontroller. It can be implemented with as few as three signal lines, since the data receive and data transmit pins may be strapped together.

Functional Description

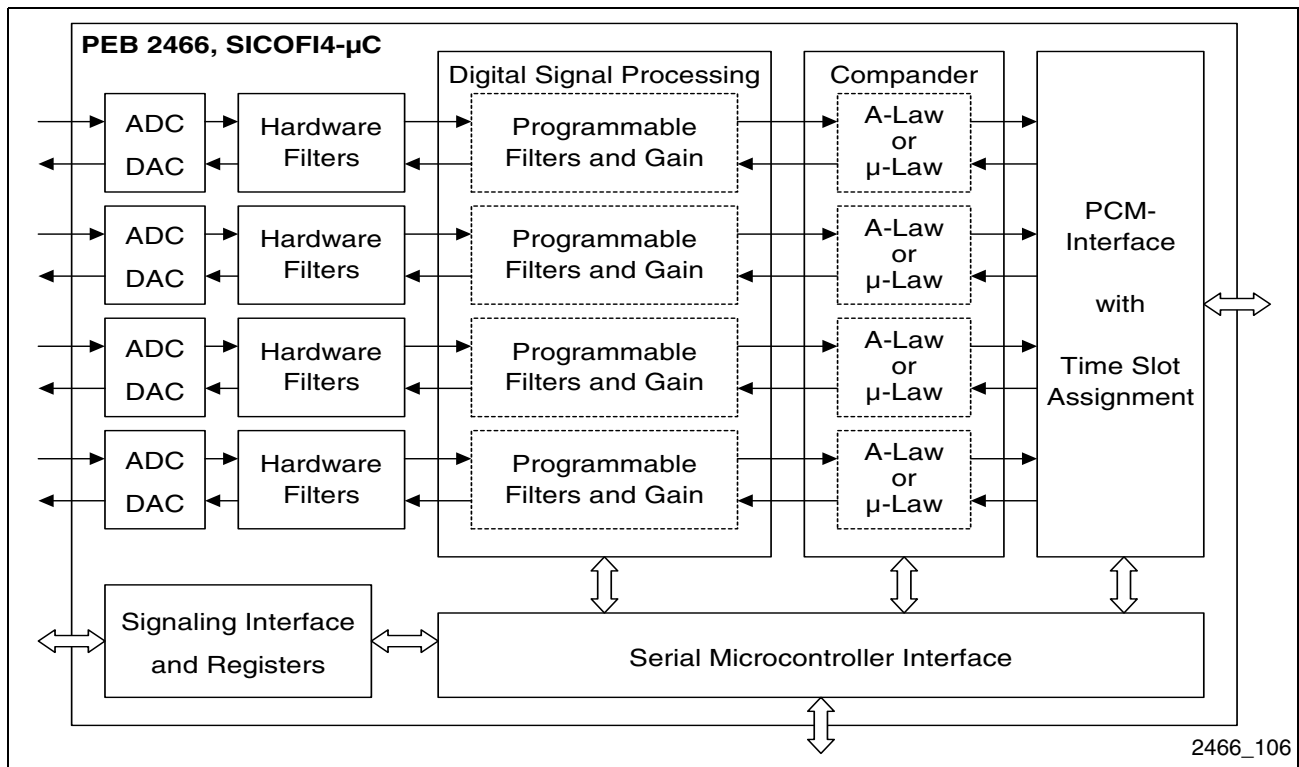

Figure 5 SICOFI®4-μC Block Diagram

2.3 Signal Flow

Telephone lines are still mostly analog, whereas the Public Switched Telephone Network (PSTN) is based on digital switching and transmission. The SICOFI®4-μC is an excellent device to interface between these two worlds. The 4-channel codec can be used with both integrated and discrete SLICs. The new sigma-delta Analog-to-Digital Converter and Digital-to-Analog Converter with high resolution and accuracy guarantee sufficient gain range in the digital part and achieve excellent performance. Analog anti-aliasing prefilters, smoothing postfilters, and specific hardware filters are integrated on-chip. The specific hardware filters do the decimation and interpolation for the oversampling ADC and DAC. This stabilizes the load for the DSP under different linecard conditions.

As shown in **Figure 5**, the dedicated DSP handles all the necessary algorithms (e.g. for PCM bandpass filtering, sample rate conversion, impedance matching, transhybrid balancing, and PCM compression and expansion). The industry-standard PCM Interface allows access to two PCM Highways for easy integration into existing switching and transmission systems. The data rate for the two PCM Highways is the same for both Highways due to shared clocks and is configurable from 128 kbit/s to 8 Mbit/s. The PCM Interface handles digital voice transmission, including A-Law and μ-Law conversion. The Serial Microcontroller Interface manages feature control and programming and provides easy access to the logic state of the SLIC's command and indication pins. For more details on interfaces refer to **Chapter 4** "Interface Description" on page 13.

2.4 Functional Blocks

The PEB 2466 provides excellent transmission performance and high flexibility. All functional blocks shown in **Figure 6** exist for all four channels and each can be fully programmed independently. The advanced digital filter concept also leads to maximum independence between the different filter blocks within the channels.

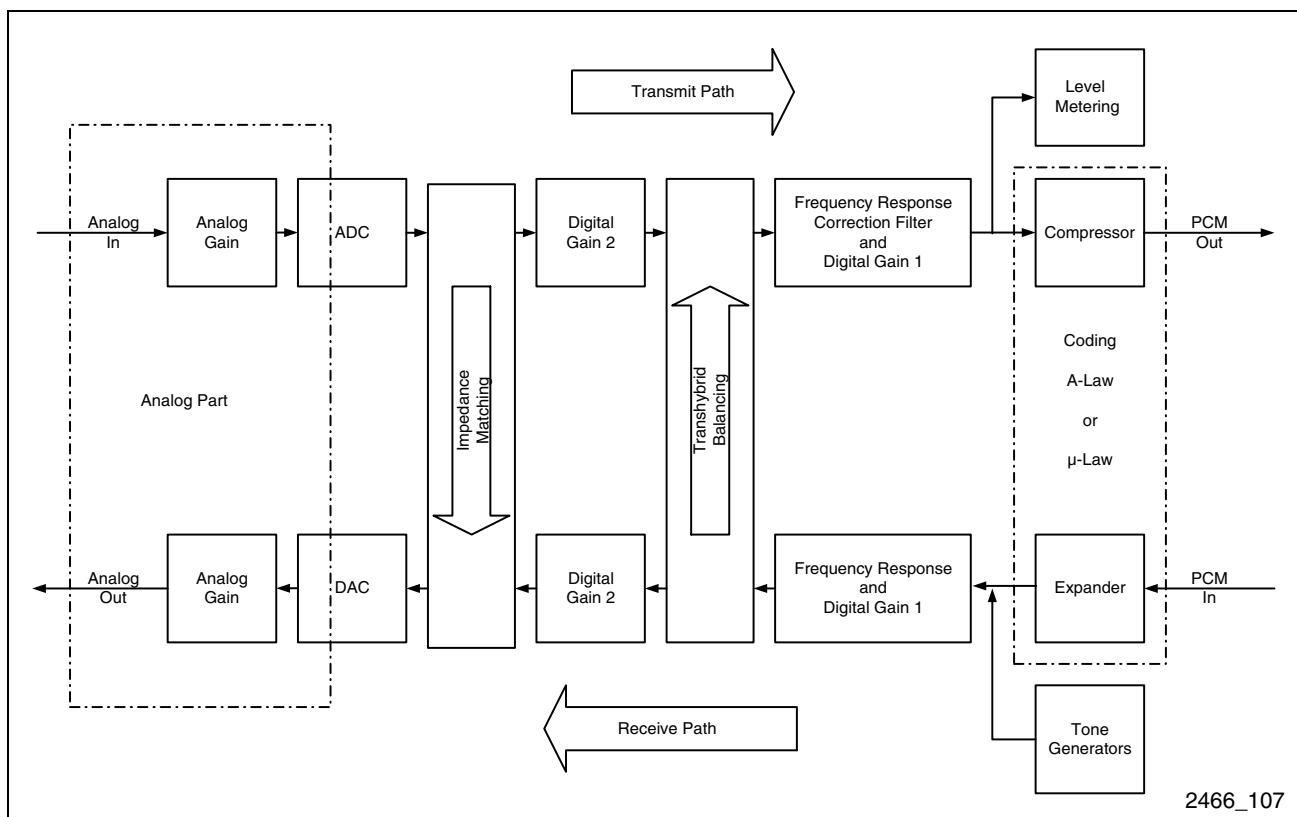

Figure 6 SICOFI®4-μC Simplified Flow Diagram

Analog Gain

Analog Gain stages with 6.02-dB amplification in the transmit direction and 6.02-dB attenuation in the receive direction can be activated through the SICOFI®4-μC configuration registers.

ADC/DAC

Advanced, oversampling sigma-delta Analog-to-Digital Converter and Digital-to-Analog Converter (ADC and DAC) achieve excellent performance in terms of linearity, accuracy, dynamic range, and resolution.

Digital Gain 2

The digital gain stages in both transmit and receive directions allow signal level adjustments with very fine granularity.

Impedance Matching

The programmable loop filters which feed portions of the transmit signal back to the receive path allow highly accurate and stable impedance synthesis of the linecard's AC input impedance.

Transhybrid Balancing

A certain portion of the receive signal is reflected on the hybrid inside the SLIC, resulting in an echo signal on the transmit path. The SICOFI[®]4- μ C provides a loop filter from the receive path to the transmit path that can be programmed to generate an equivalent of the echo signal. If the equivalent is subtracted from the transmit signal, it cancels the echo produced by the hybrid. This function, called transhybrid balancing, is implemented by programmable loop filters that allow adjustments to different line conditions.

Frequency Response Correction Filters and Digital Gain 1

An analog linecard must fulfill the country-specific requirements for frequency response behavior. The SICOFI[®]4- μ C provides digital correction filters in both signal directions between the PCM side and the Analog Interface. These programmable filters and digital gain stages are used to adjust the overall system's frequency response behavior.

A-Law / μ -Law Compressor and Expander

The PCM encoded speech signals use an 8-bit format with G.711 A-Law or μ -Law compression. For better performance, the DSP inside the SICOFI[®]4- μ C processes 16-bit linear speech samples. The conversion is performed by compressor and expander units between the PCM Interface and the digital filter structures of the SICOFI[®]4- μ C. These blocks can be selected as either A-Law or μ -Law through the configuration registers.

Level Metering

This block compares the level of a band-pass filtered signal on the transmit path with a programmable offset value. The signal can be applied externally or internally by one of the on-chip tone generators. The function can be used for line characterization, field diagnostics, or functional tests.

Tone Generators

Two independent tone generators are available as on-chip signaling and call-progress tone sources. They also provide the test signal for dynamic system diagnostics, including line characterization when used in combination with the level metering function. In non-linecard applications, the tone generators can also be used for DTMF dialing.

3 Operational Description

For system power management, each channel of the SICOFI[®]4- μ C can be programmed to be in one of two states: “Standby” and “Operating”. “Standby” is a power-saving state. Keeping all unused channels in this state reduces the overall system power dissipation. After applying power to the device (Power On), or after asserting a logic low signal to the RESET# pin (HW Reset), or after programming the RESET bit in the configuration registers, all four channels will be initialized and will enter the “Standby” state. From there, each channel can be switched separately to “Operating” state and back, by programming a bit in the channel-specific configuration registers.

3.1 Operating States

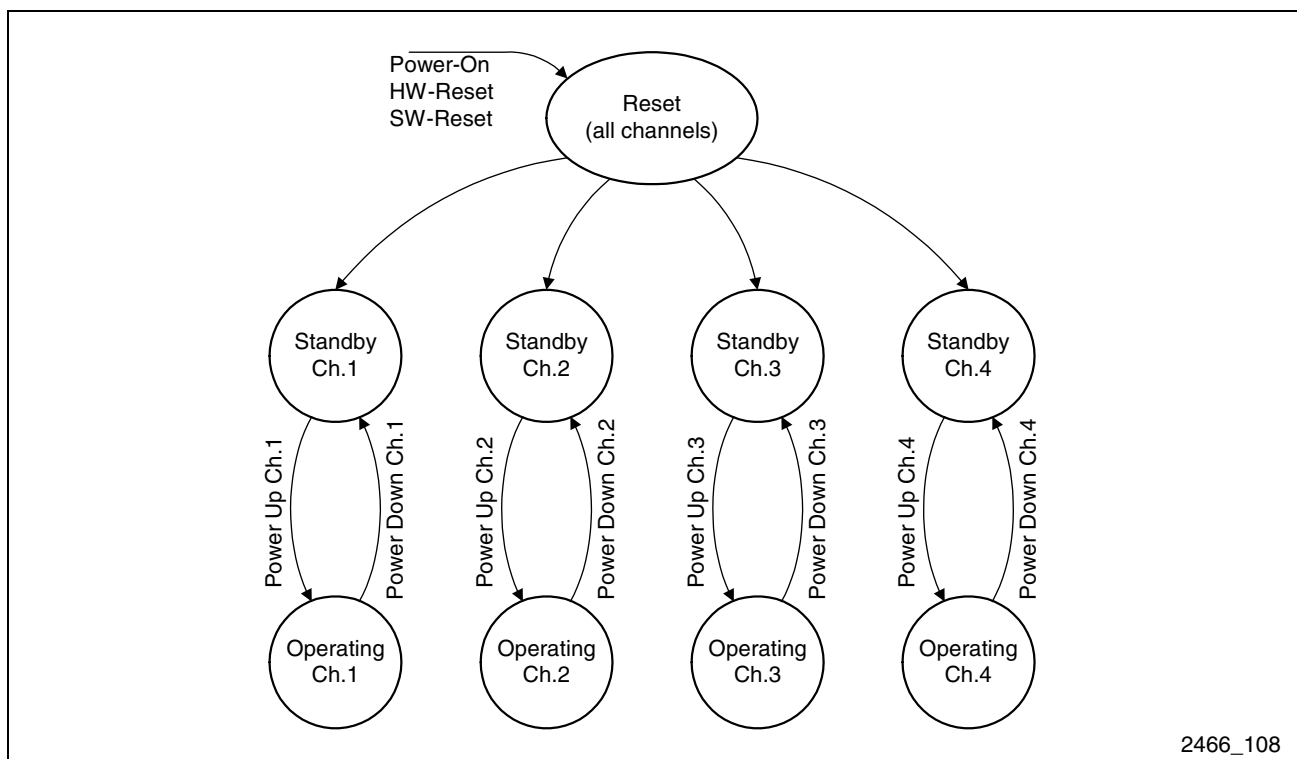

Figure 7 SICOFI[®]4- μ C Simplified State

Reset (Default Setting)

The SICOFI[®]4- μ C enters a default setting Reset state upon initial application of power to the device (Power On), or when the RESET# pin is pulled to ‘0’ during operation (HW Reset), or by programming the RESET bit in the configuration registers (See XOP command in the *Programmer’s Reference Manual*). Default setting means that the SICOFI[®]4- μ C configuration registers of all channels are set to their default values and the I/O pins of the different interfaces exhibit a defined behavior.

Operational Description

All programmable filters, the two tone generators, as well as any test modes, are disabled. The signaling outputs are forced to ground. All programmable command/indication pins are inputs. The debouncing functions are disabled. Receive signaling registers are cleared. Data output of the Serial Microcontroller Interface and the analog outputs are in high impedance state. The SICOFI[®]4- μ C leaves this state automatically after the RESET# pin is released.

Standby

“Standby” is a power-saving state. Keeping all unused channels in this state reduces the overall system power dissipation. After releasing the RESET# pin, the SICOFI[®]4- μ C will enter the Standby state. Individual channels of the SICOFI[®]4- μ C can be forced to Standby state when Power Down is set in the channel configuration registers. All four channels must be programmed separately. In Standby, the Serial Microcontroller Interface of the SICOFI[®]4- μ C is ready to receive and transmit commands and data. Received voice data on the PCM Interface will be ignored. SICOFI[®]4- μ C configuration registers and Coefficient RAM can be loaded and read back in this state. The debouncing functions of the Signaling Interface can be enabled and data on the signaling input pins can be read via the Serial Microcontroller Interface.

Operating

The “Operating” state for any channel in the SICOFI[®]4- μ C is entered upon recognition of a Power Up bit set to “1” in a configuration register for that specific channel. For any channel set to Operating state, the voice transmission works in both directions. Voice data applied to the PCM-input and the Analog-input will be processed according to the programmed contents of the internal registers and filter coefficients, and will appear as Analog-output and PCM-output. Programmable filters and tone generators can be enabled. The debouncing functions of the Signaling Interface can be enabled.

4 Interface Description

The SICOFI[®]4- μ C provides four interfaces (Analog, PCM, Signaling, and Microcontroller) for flexible and efficient design implementations. The AC characteristics of the Analog Interface are programmable to enable quick software adaptations to country-specific transmission requirements. The programming is done through the Serial Microcontroller Interface, which also provides access to the device's status and control registers. The Signaling Interface is used to monitor and control the status of the SLIC and the telephone line. Interrupt outputs can be enabled to alert the microcontroller of any change that occurred on the Signaling Interface (e.g. off-hook detection). The PCM Interface transmits and receives A-Law or μ -Law encoded data on two PCM Highways with speeds up to 8192 kbit/s each.

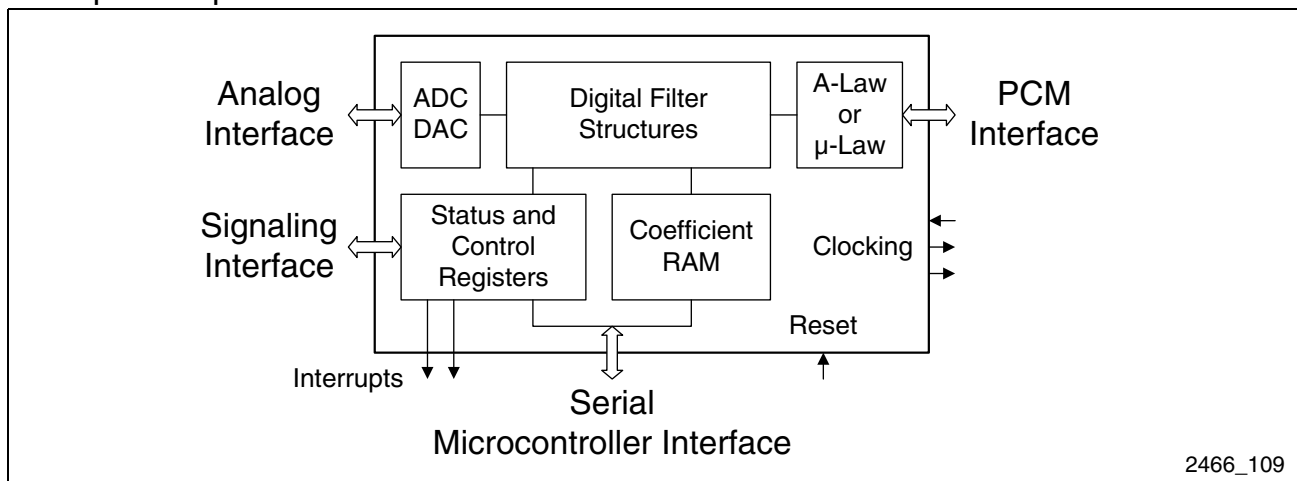

2466_109

Figure 8 SICOFI[®]4- μ C Interfaces

4.1 Analog Interface

The SICOFI[®]4- μ C includes a programmable Analog Interface with high driving capability for interfacing to electronic SLICs or transformer solutions. The SICOFI[®]4- μ C can drive loads of up to 300 ohms, eliminating the need for an external amplifier that is normally used with transformer SLICs. The only external component needed between the analog I/O pins of the SICOFI[®]4- μ C and the SLIC is a coupling capacitor. (See the *Hardware Reference Manual* for further detail.) Out-of-band signals applied to the analog inputs are suppressed by the on-chip digital hardware filters. The poles of these filters are fixed at 12 kHz and 16 kHz which suppresses the echo signal from teletax pulses very efficiently: As long as the amplitude of the teletax echo stays below the overload threshold of 1.57 Vrms, the voice signal in the transmit path will not be disturbed. Thus, the on-chip hardware filters can eliminate the need for external teletax filters.

4.2 PCM Interface

The serial PCM Interface is used for the transfer of A- or μ -Law compressed voice data. The PCM Interface consists of 8 pins: one PCM Clock, one Frame Synchronization Clock, two Receive Data Inputs, two Transmit Data Outputs, and two Transmit Control Outputs. The Frame Sync (FSC) pulse identifies the beginning of a receive and transmit frame for all four channels. The PCM Clock (PCLK) is the signal used to synchronize the data transfer on both PCM Highways. The PCM Clock (PCLK) is the signal used to synchronize the data transfer on both PCM Highways.

The data rate of the PCM Interface can vary from 2 x 128 kbit/s to 2 x 8192 kbit/s (two highways). A frame may consist of up to 128 time slots of 8-bits each. Any of the four voice channels can be assigned to any time slot on either PCM Highway. Receive and transmit time slots can also be programmed independently. Since PCM Highway structures may vary from system to system, the SICOFI[®]4- μ C facilitates adaptations with a programmable sampling slope and delay of up to seven clocks, valid for all channels.

Transmit Control Output pins (TCA# and TCB#) indicate the active time slot during data transmission on the Transmit Data Outputs (DXA, DXB). They may be used to control external tristate buffers driving the PCM Highway.

4.3 Signaling Interface

The SICOFI[®]4- μ C Signaling Interface provides 28 general purpose digital I/O pins. The logic state of each pin is reflected in dedicated on-chip registers. There are two inputs, two outputs, and three programmable bi-directional pins per channel. Automatic debouncing of the input signals, with configurable debouncing periods, can be enabled. Additionally, two interrupt outputs (INT12, INT34) are provided.

The Signaling Interface is used to implement line supervision, SLIC status monitoring and control, and switching of ringing or test relays, etc. The SICOFI[®]4- μ C accumulates and manages the I/O status of four SLICs. If programmed, any change on the signaling inputs generates an interrupt that alerts the microcontroller: INT12 indicates signaling changes on Channels 1 and 2; INT34 indicates changes on Channels 3 and 4. The microcontroller can read the signaling status directly from the SICOFI[®]4- μ C registers. If no interrupts are used, the microcontroller can still determine changes on the Signaling Interface (e.g., on-hook/off-hook) through polling. For special purposes, e.g., DC-DC converters, two programmable clocking output signals ("chopper clock" outputs) are provided by the PEB 2466.

4.4 Microcontroller Interface

A Serial Microcontroller Interface provides read and write access to the internal configurations registers, the registers of the Signaling Interface, and the Coefficient-RAM (CRAM). The Serial Microcontroller Interface consists of four pins: Chip Select, Data Clock, Data In and Data Out. To reduce the number of lines to the

Interface Description

microcontroller, Data In and Data Out may be strapped together to form a single bi-directional data line. A falling edge on Chip Select initiates a serial read or write access. The SICOFI[®]4- μ C interprets the first eight bits received via Data In as a command byte. Subsequent data bytes (the number depends on the type of command) are stored in the selected configuration registers or the selected part of the Coefficient RAM. If the first eight bits received via Data In specify a read-command, the SICOFI[®]4- μ C will initiate a response via Data Out with an identification byte (81_H), followed by the requested number of data bytes (contents of configuration registers, or contents of the CRAM). A clock signal applied to the Data Clock pin synchronizes the serial data transfer. The logic level on Data In is latched at the rising edge of Data Clock, while Data Out changes its logic level with the falling edge of Data Clock. During the execution of a read command, i.e., serial transfer on Data Out, the device will ignore any signals on Data In. The data transfer sequence can be aborted by setting Chip Select to high.

5 Application Hints

5.1 Typical Applications

The programmability of the SICOFI[®]4- μ C makes it suitable for analog linecard and trunk line interfaces in many types of telephonic equipment. The inherent flexibility of the device enables several applications and products to be developed around one basic architecture. This design versatility provides potentially significant savings in product development, inventory costs, and support. The following sections describe some of the typical applications for which the SICOFI[®]4- μ C codec was designed.

5.1.1 Analog Linecards for Central Offices and PBXs

The analog linecard is connected to the tip/ring (t/r) subscriber loops on the analog side and to the PCM Highway on the digital side. **Figure 9** shows a typical SICOFI[®]4- μ C analog linecard for 16 subscribers. Previous linecard concepts required at least two devices per channel: one SLIC and one codec. With the four-channel SICOFI[®]4- μ C, part count is reduced from 32 to 20. The Signaling Interface of the SICOFI[®]4- μ C allows the linecard's microcontroller to monitor and control the status of the subscriber line. Each PEB 2466 device provides 28 I/O signals which can be accessed through registers. The same linecard microcontroller is used to load the filter coefficients into the SICOFI[®]4- μ C.

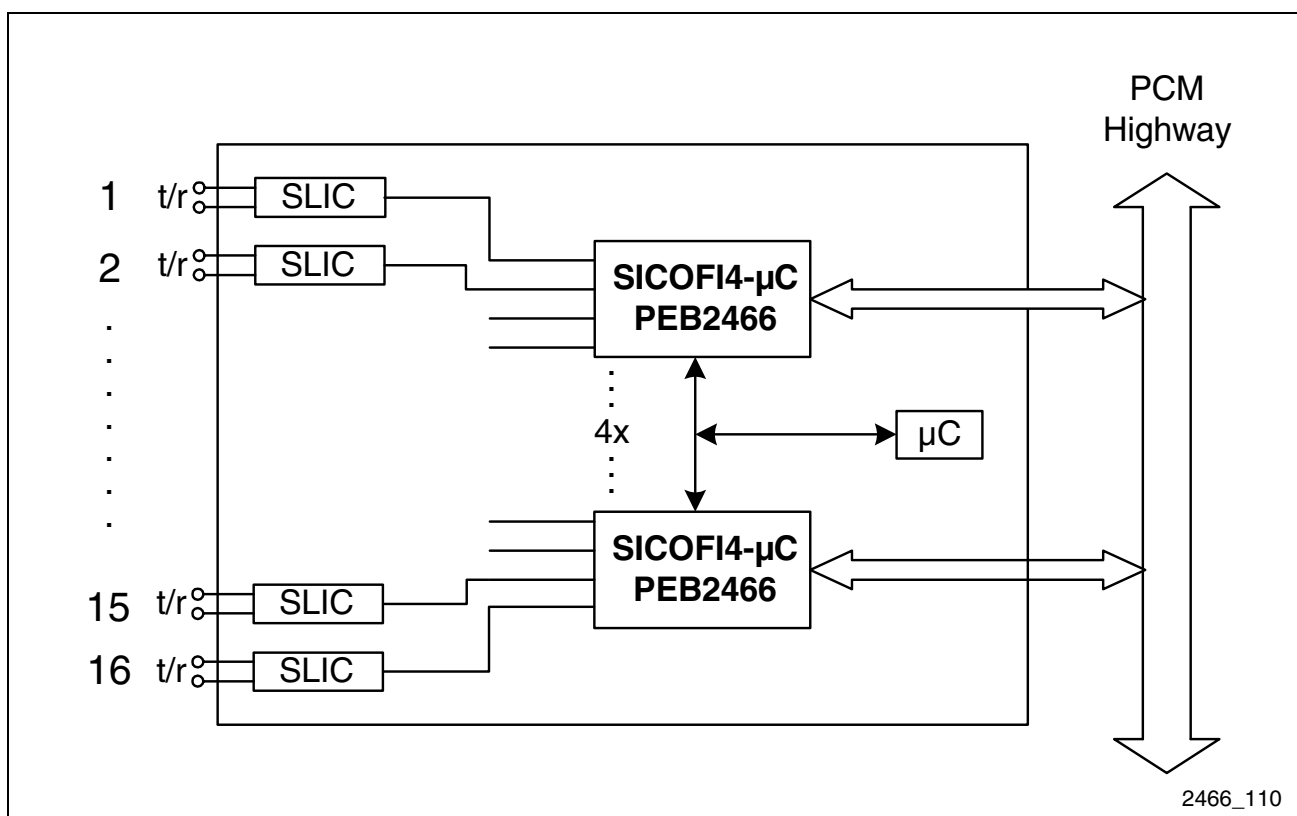

Figure 9 Analog Linecard Example for Central Offices and PBXs

5.1.2 Small PBX or Key Systems

A small PBX system can be designed using only a few components. Such a system often combines trunking, switching, and linecard functions on a single board. In this application, one SLIC per subscriber is necessary as well as one SICOFI[®]4- μ C per four analog subscribers. The SICOFI[®]4- μ C is also used to connect the PCM backbone to the analog trunk line. The MUSAC-A Multipoint Switching and Conferencing IC connects trunk and subscriber channels as well as providing conference call functionality.

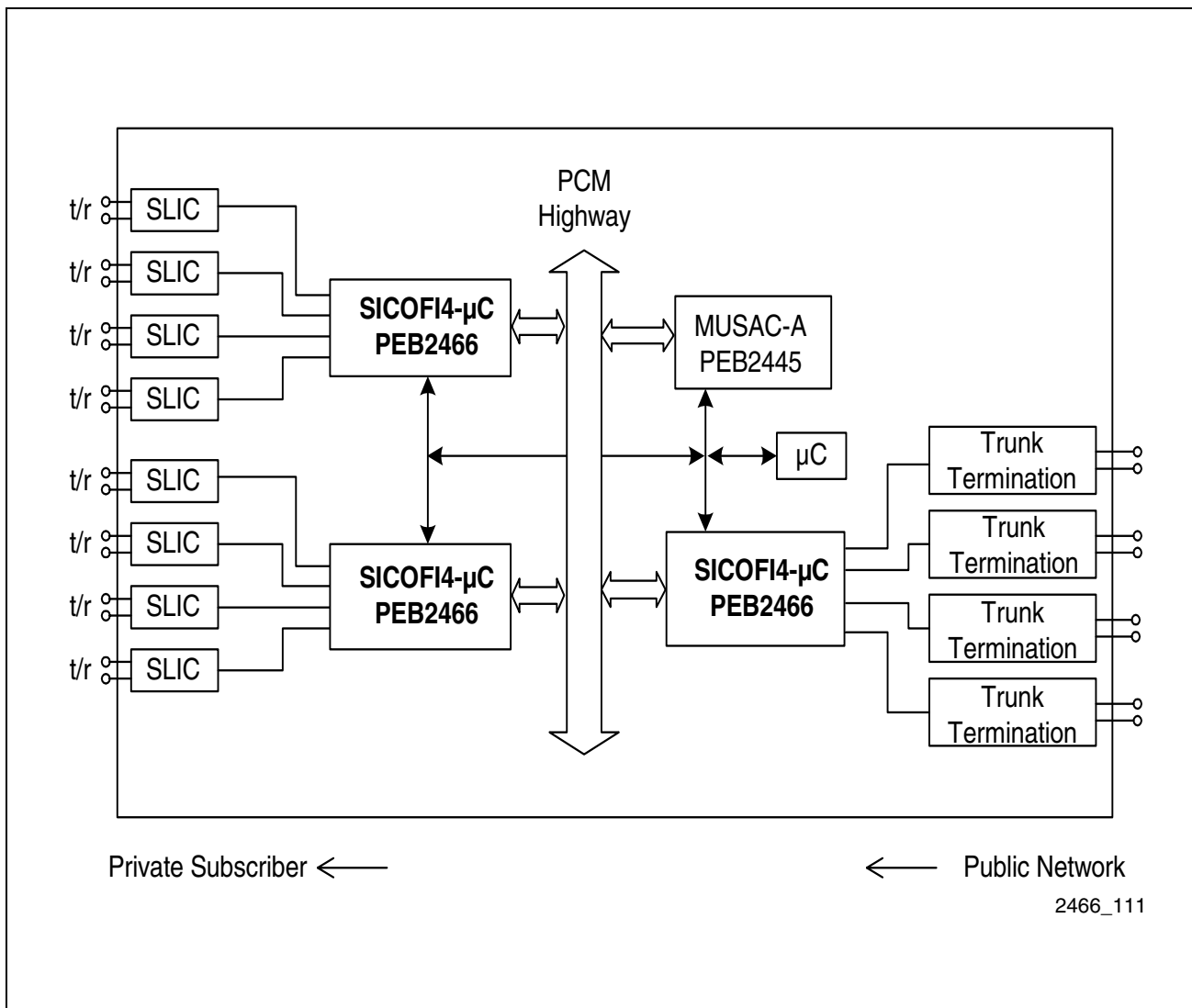

Figure 10 Small PBX or Key System Example

5.1.3 Digital Loop Carrier (DLC) Systems

A Digital Loop Carrier (DLC) system consists of two main functional units: the Central Office Terminal (COT) and the Remote Terminal (RT). The COT connects to the subscriber linecards of the Central Office and multiplexes many subscriber channels onto primary rate or fiber links to the RT. The RT de-multiplexes the received channels and provides local analog subscriber loops to its service area.

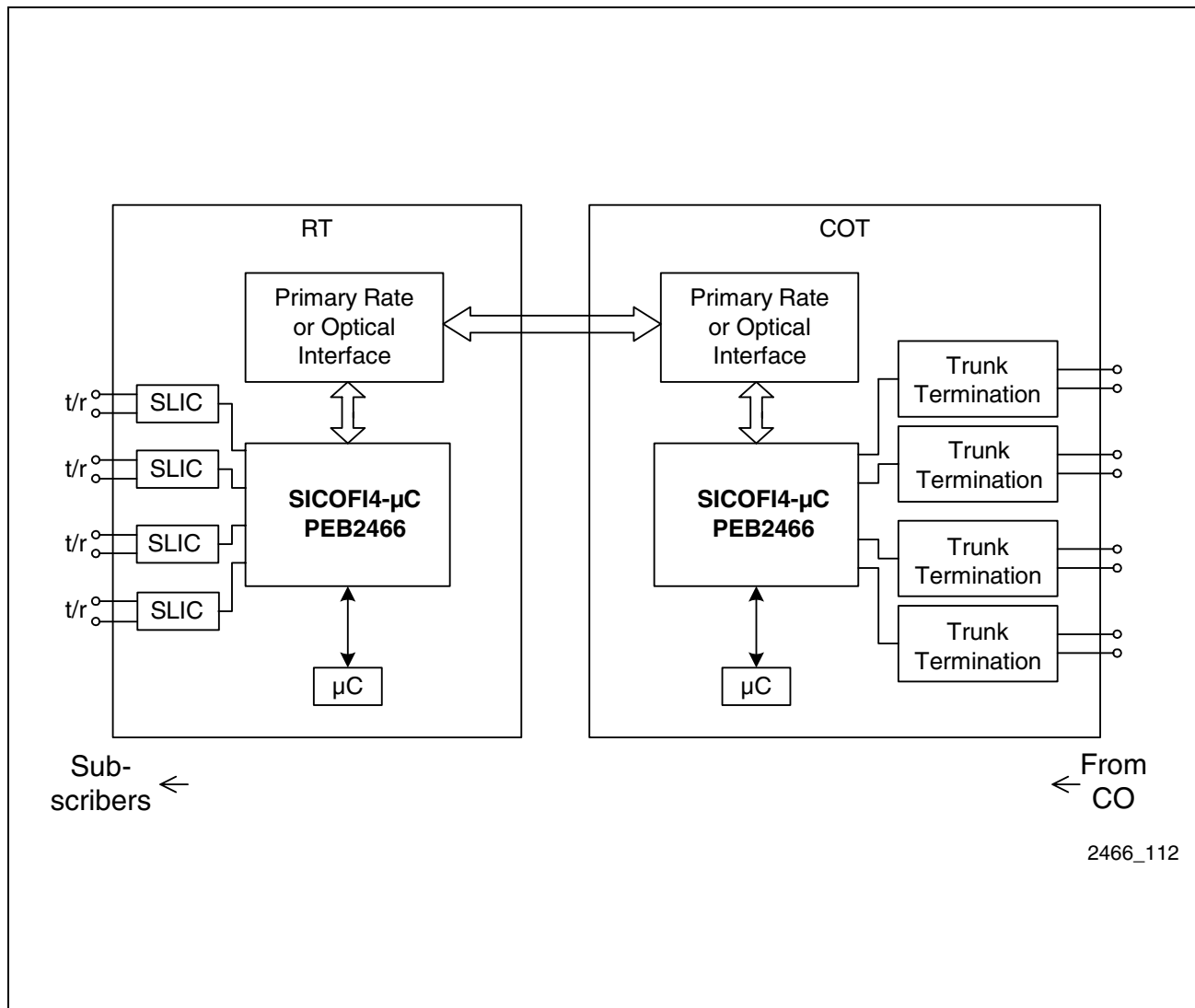

Figure 11 Digital Loop Carrier System Example

5.1.4 PCM4 Systems

A PCM4[®] (Pulse Code Modulation for 4 channels) system compresses speech band signals between an exchange and its subscribers. Thus, four calls can be transmitted over one copper wire pair. The PCM4 chipset consists of three chips: the SICOFI[®]4- μ C (PEB 2466) handles the digital/analog conversion and controls the tip/ring (t/r) interface in the Remote Terminal (RT) and in the Central Office Terminal (COT); the ADPCM (PEB 7274) compresses and decompresses the PCM signals; and the IEC-Q (PEB 2091) ISDN-U transceiver establishes the physical connection between the RT and the COT. All three of the chips are controlled by a single microcontroller.

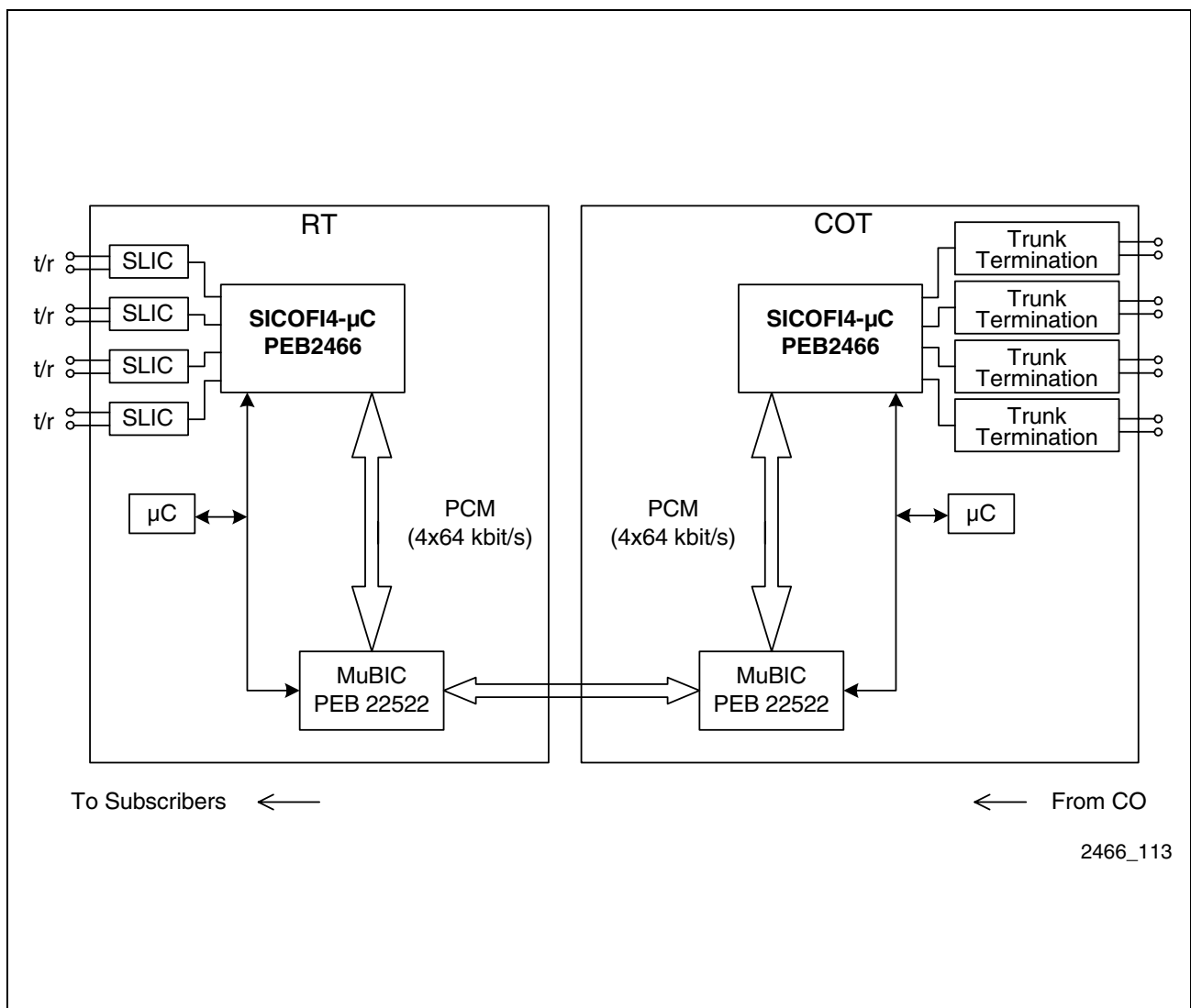

Figure 12 PCM4 System Example

5.1.5 Fiber-to-the-Curb (FTTC) Systems

A Fiber-to-the-Curb system connects several Remote Terminals in specific service areas to a Central Office. The connection between the Central Office and the Remote Terminal is an optical fiber which carries digital PCM data. Subscribers can be connected to the Remote Terminal through existing copper wiring. The SICOFI[®]4- μ C in the Remote Terminal converts the PCM channel into analog signals. It also controls the SLICs that drive the tip/ring (t/r) lines.

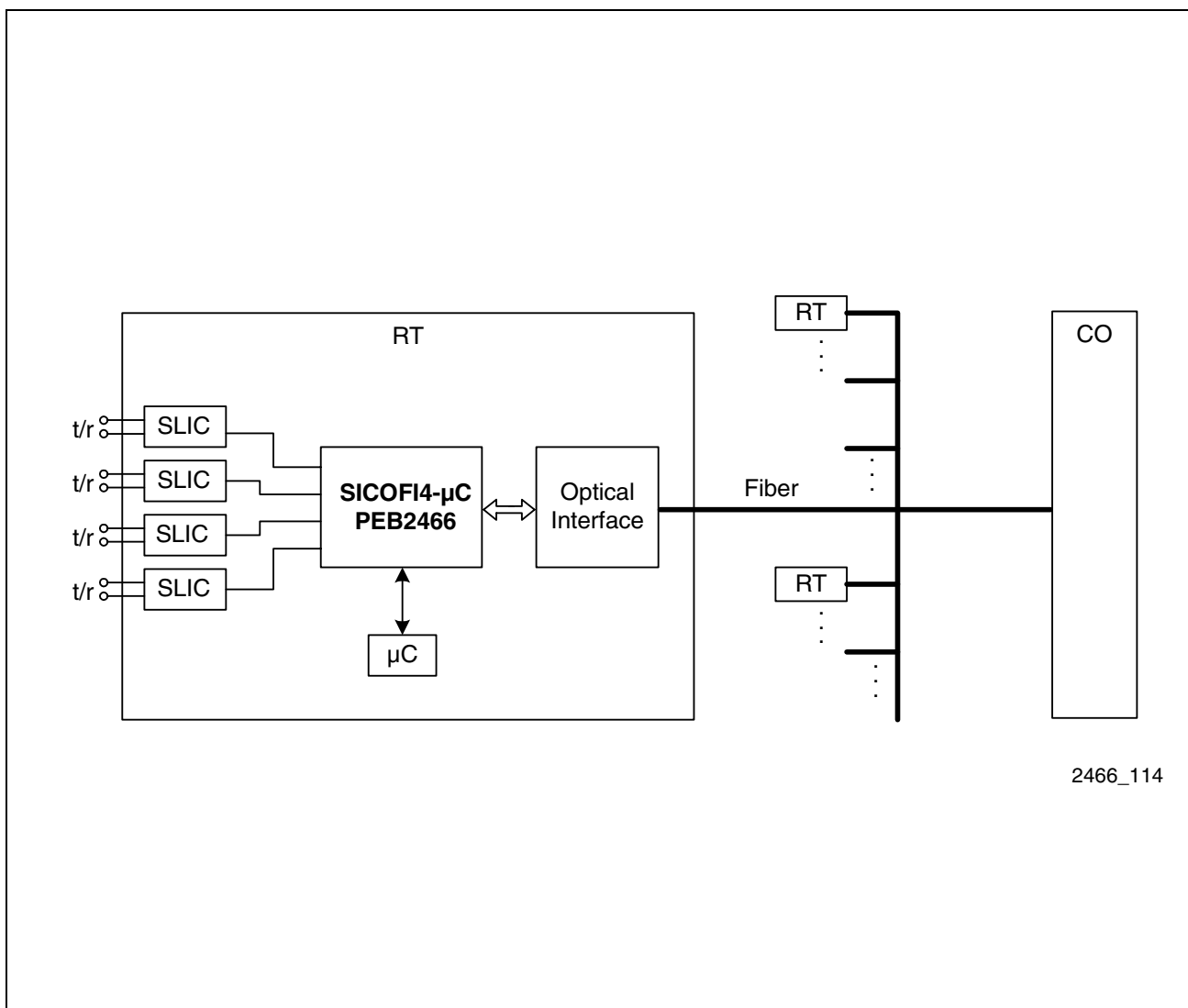

Figure 13 Fiber-to-the-Curb System Example

5.1.6 Radio-in-the-Loop (RITL) Systems

A Radio-in-the-Loop system uses digital radio transmission for bridging the last mile. The digital two-way radio on the customer's premises converts the digital PCM code and provides analog telephone service over tip/ring (t/r) lines. The SICOFI[®]4- μ C used in this application converts the digital signals to analog signals. Up to four analog lines can be supported by each SICOFI[®]4- μ C device.

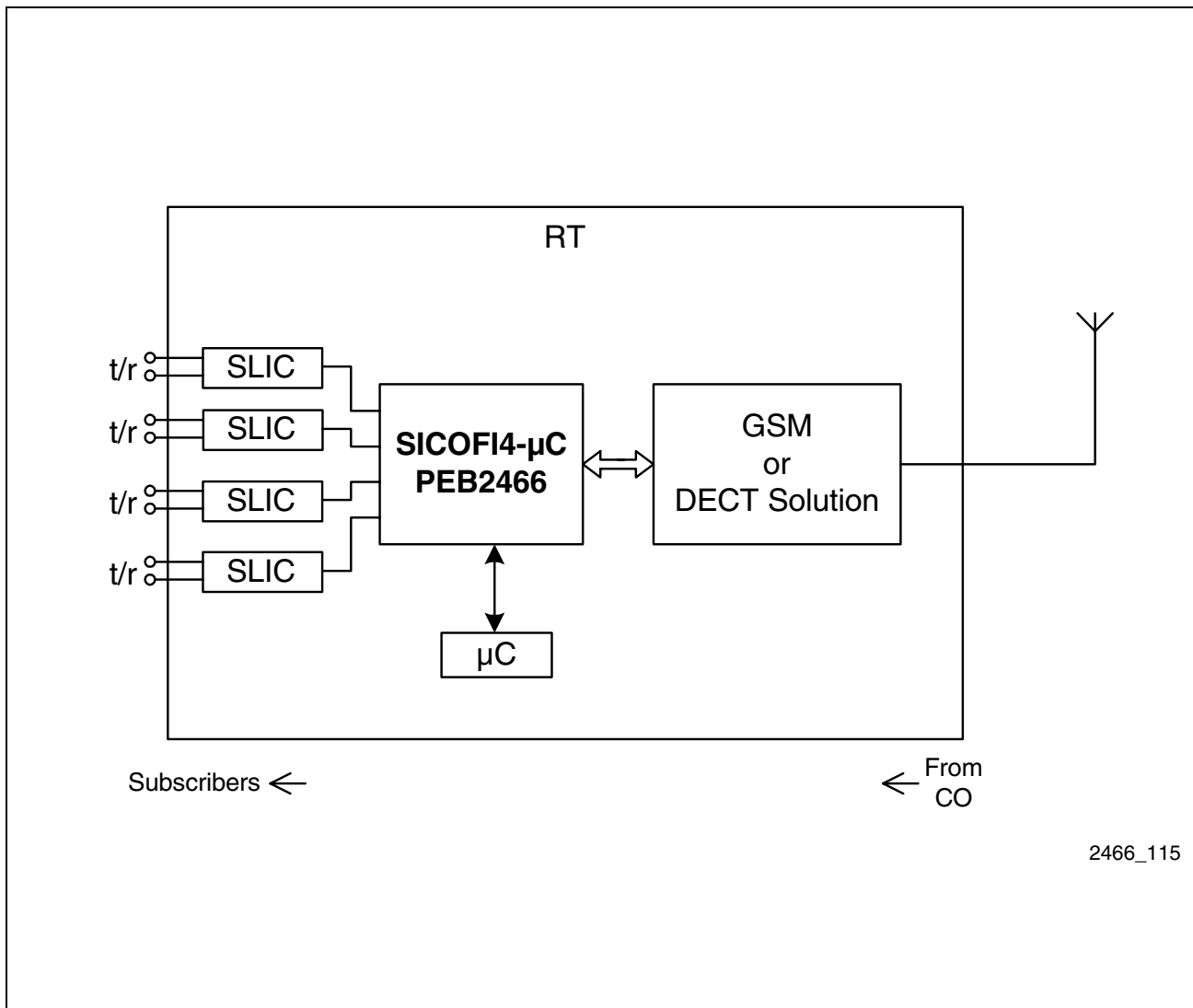

Figure 14 Radio-in-the-Loop System Example

5.2 Support Tools

5.2.1 QSICOS Software

The programmable filters of the SICOFI[®]4- μ C enable adaptation of the AC system behavior to the linecard circuit, especially to the SLIC and the given country-specific line characteristics.

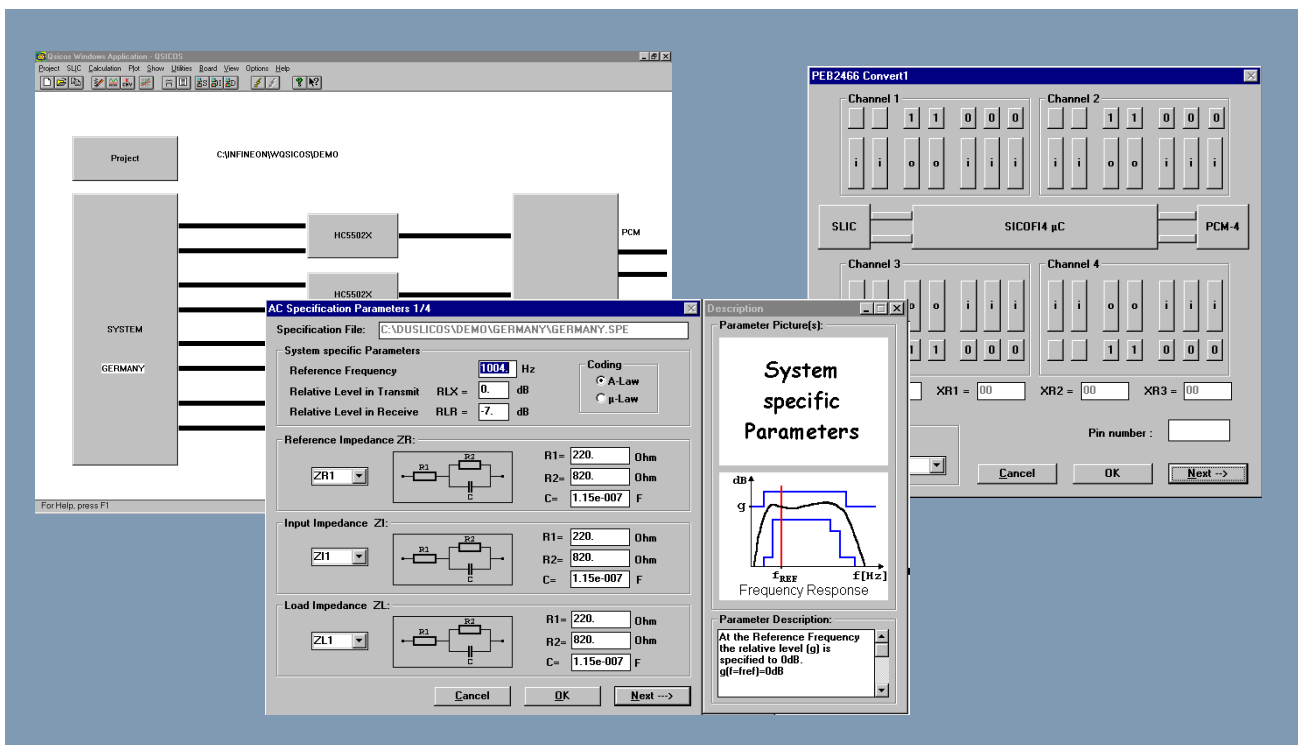

Figure 15 Dialogs of the QSICOS Coefficients Software

The Windows based **Quad SICOFI Coefficient Software (QSICOS)** **Figure 15** allows the calculation of optimized sets of coefficients for programming the SICOFI[®]4- μ C.

As shown in **Figure 16**, the QSICOS software needs the following input files for coefficient optimization:

1. External Circuit Description (K-Parameter Interface File):

K-parameters are used to describe the electrical properties of the external circuit.

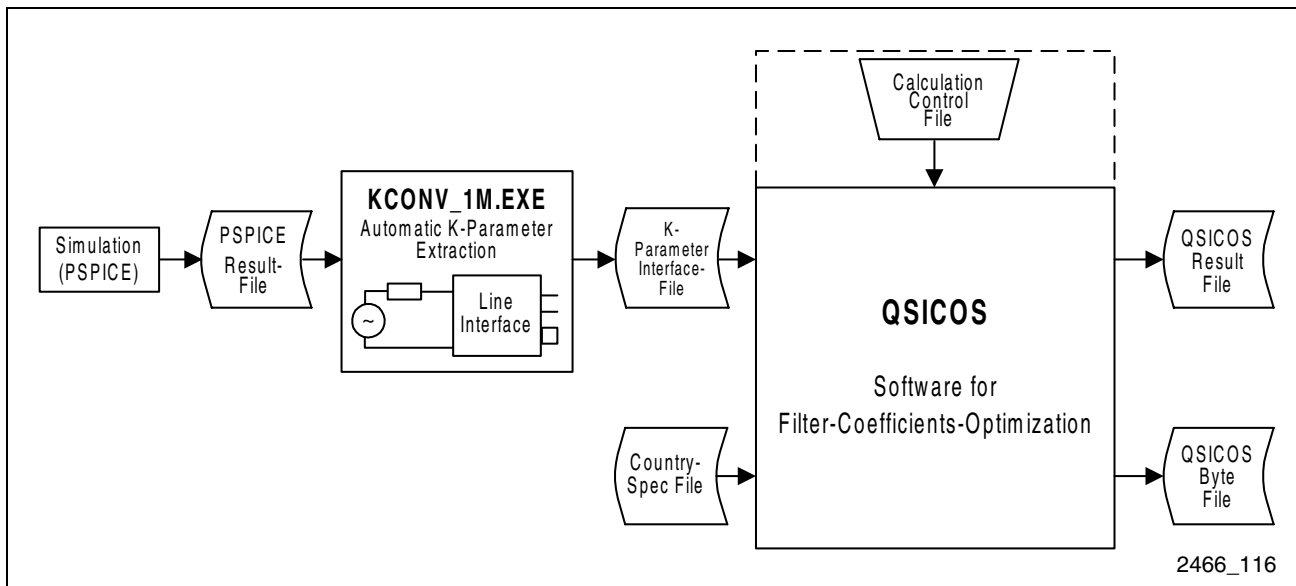

Figure 16 Input Files of QSICOS

To obtain the K-parameters, the results of a Windows based PSPICE® simulation of the external circuit are converted using the conversion program “KCONV_1M.EXE”.

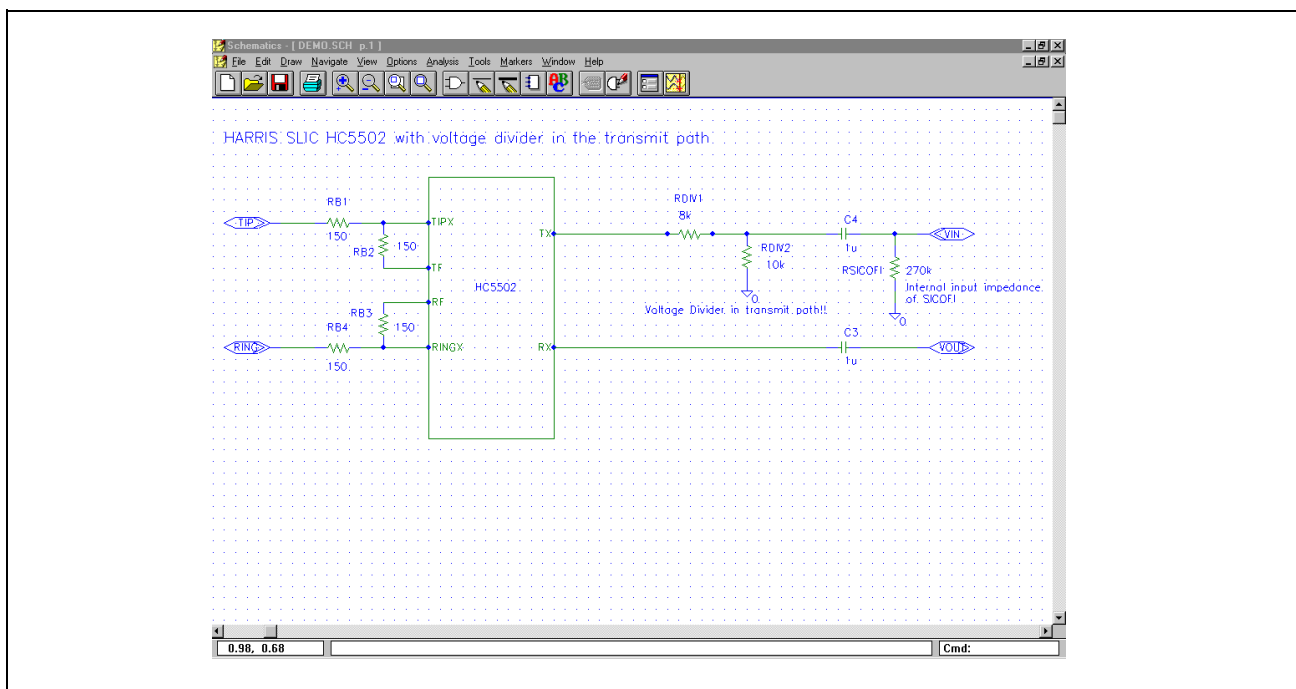

Figure 17 PSpice Schematic Editor

The conversion calculations are made in accordance with the three-port theory. Both the PSPICE Electrical Circuit Simulation Program **Figure 17** (Evaluation Version, V6.2) and the “KCONV_1M.EXE” conversion program are provided with the QSICOS Coefficient Calculation and Register Configuration Software.

2. PTT Specifications (Country-Spec File):

The particular PTT specifications and the targeted AC behavior are described in the Country-Spec File.

The QSICOS software uses the input from the K-Parameter Interface File and the Country-Spec File to calculate filter coefficients which fulfill the PTT-defined/required AC behavior (**Figure 18**) for the whole system. A Calculation Control File provides additional input information on the optimization process.

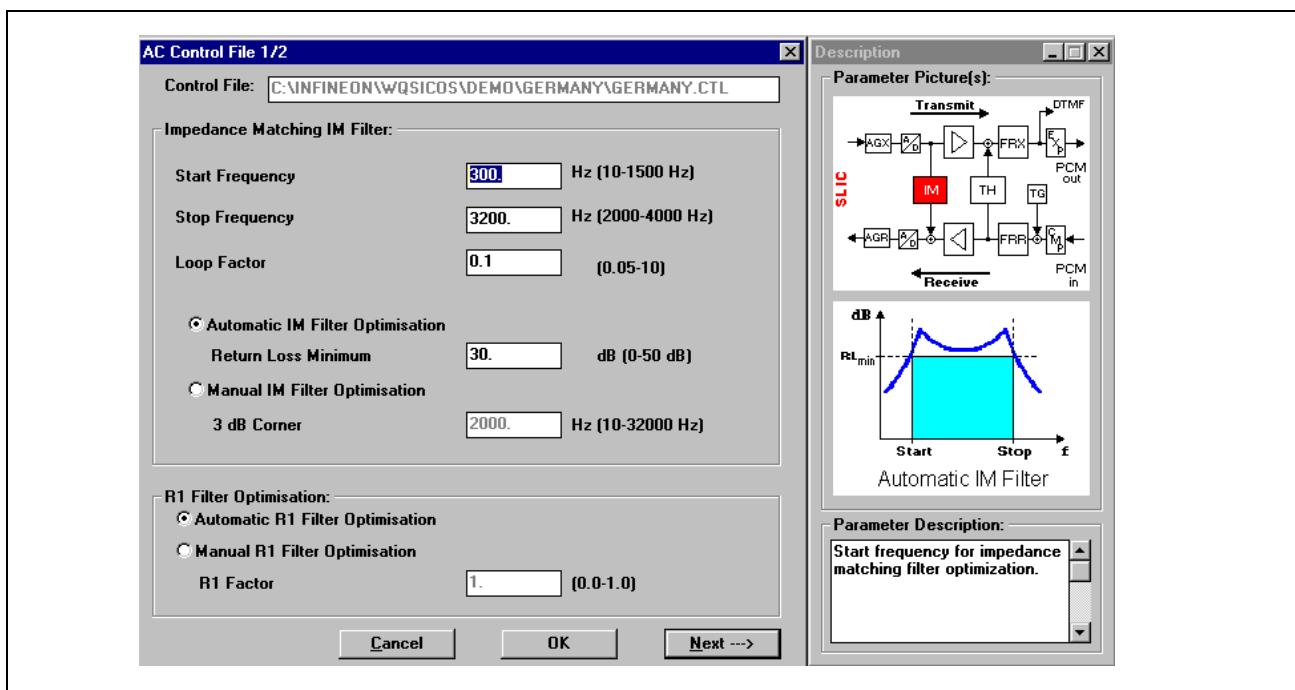

Figure 18 Parameter Settings of the Control File

QSICOS calculates coefficients for the following filters:

- Impedance Matching to adapt the system to the required line-impedance of the local loop (return loss calculation),
- Frequency Response Correction for both the receive and transmit paths,
- Level Adjustment for both the receive and transmit paths,
- Transhybrid Balancing, and
- Two programmable Tone Generators.

During the optimization process, the system behavior is calculated for the desired SLIC and the SICOFI[®]4- μ C. Some calculated functions can be displayed graphically to enable the product designer to quickly verify the required behavior and to easily make any additional optimizations manually. The following calculations are displayed graphically:

- Return loss,
- Frequency response in the receive and transmit paths, and
- Transhybrid loss.

An important feature of the QSICOS software is the ability to verify the calculated coefficients against criteria necessary to maintain overall system stability. The QSICOS software produces both a Byte File and a Result File. The Result File contains all of the numerical simulation results data as well as the programming bytes. After the calculation process the evaluation board can be directly programmed via the QSICOS user control.

5.2.2 EASY 2466 Tool Package

The EASY 2466 Tool Package includes the Evaluation Board which allows simple programming of the SICOFI[®]4- μ C using a personal computer (PC). Conversion utilities are also provided in the tool package which convert the Byte File from the QSICOS software into a downloadable file usable by the evaluation board. This enables the product designer to compare the actual behavior of the hardware against the calculated results from the QSICOS software.

The EASY 2466 evaluation system has connectors for a test instrument to measure the transfer characteristics (e.g., the PCM-4 Channel Measuring Set by Wandel & Goltermann). This feature provides the option of system verification and fine-tuning. When the product designer has produced a set of coefficients which fulfill all required criteria, the values stored in the Byte File can be downloaded to the target hardware via the QSICOS user control, see at **Figure 19**.

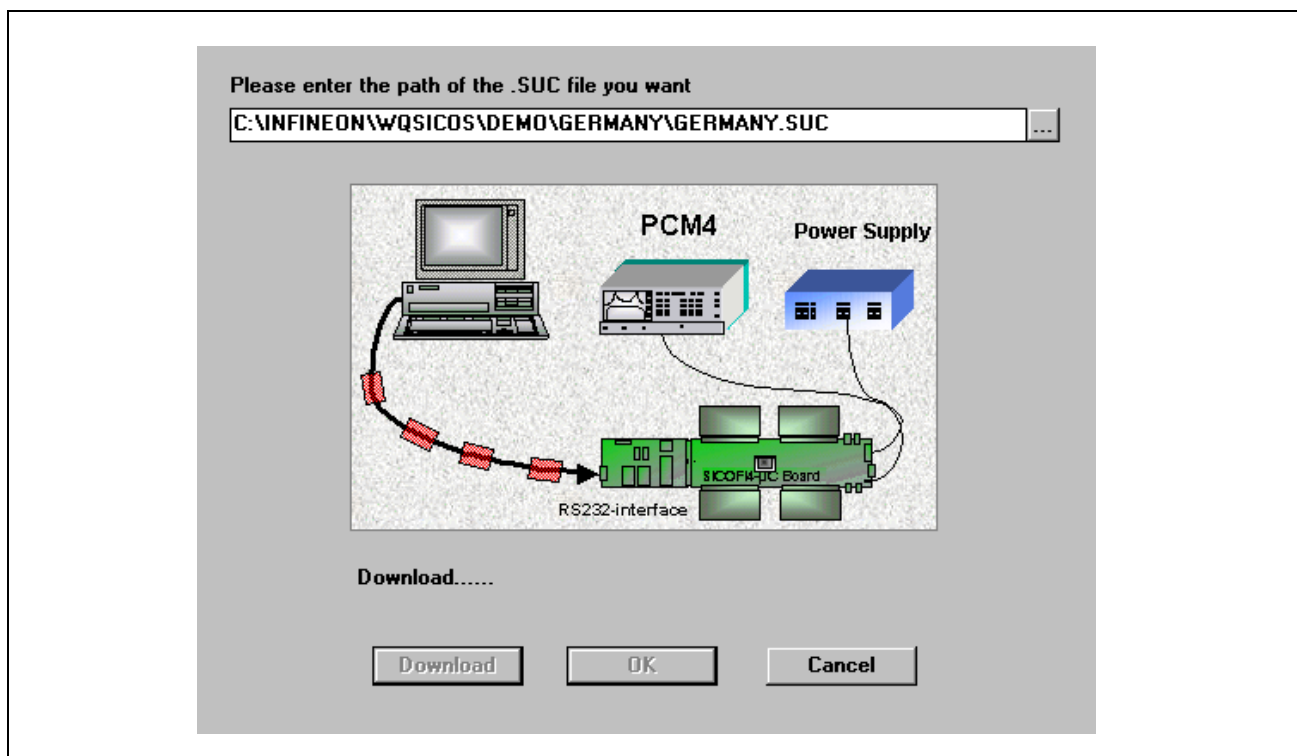

Figure 19 Dialog for Programming the Evaluation Board

6 Glossary

AC	A lternating C urrent
ADC	A nalog-to- D igital C onverter
CMOS	C omplementary M etal O xide S emiconductor
CO	C entral O ffice
COT	C entral O ffice T erminal
CRAM	C oefficient- R AM
DAC	D igital-to- A nalog C onverter
DC	D irect C urrent
DLC	D igital L oop C arrier
DSP	D igital S ignal P rocessor
DTMF	D ual T one M ulti F requency
FTTC	F iber- T o- T he- C urb
IOM-2	I SDN- O riented M odular 2 nd G eneration
ISDN	I ntegrated S ervices D igital N etwork
ITU	I nternational T elecommunication U nion
ITU-T	I nternational T elecommunication U nion- T elecommunication Standardization Sector (formerly CCITT)
NT	N etwork T ermination
PBX	P rivate B ranch E xchange
PCM	P ulse C ode M odulation
PSTN	P ublic S witched T elephone N etwork
PTT	P ost T elephone T elegraph
QSICOS	Q uad S ICOFI C oefficient S oftware
RITL	R adio- I n- T he- L oop
RT	R emote T erminal
SICOFI	S ignal P rocessor C odec F ilter
SLIC	S ubscriber L ine I nterface C ircuit
t/r	tip/ring

Index

Symbols

μ -Law 8, 10, 13

Numerics

2-wire to 4-wire conversion. 7

A

A/ μ -Law compression / expansion 4
 AC behavior 24
 AC characteristics 13
 AC input impedance 10
 Access networks 2
 ADC 4, 8, 9
 ADPCM 19
 A-Law 8, 10, 13
 Analog filters 2
 Analog gain 9
 Analog interface 5, 13
 Analog linecards 16
 Analog loops 4
 Analog outputs 12
 Analog trunk line 17
 Analog-to-digital converter 9
 Anti-aliasing 8
 Application Notes 1

B

Bandpass filtering 8
 Bi-directional pins 14
 Block diagram 8

C

Call-progress tone 10
 Central Office Terminal (COT) 18, 19
 Central offices 2, 16
 Channel measuring set. 25
 Chip select 14

Chopper clock 14
 Coefficient calculation and register configuration software 3, 4, 7
 Coefficient optimization 22
 Coefficient RAM. 12, 15
 Coefficients 3, 7, 25
 Command bytes 15
 Command/indication pins 12
 Commands 12
 Compression 4, 8
 Compressor 10
 Configuration registers 10, 11, 12, 15
 Conversion utilities 25
 COT 18
 Country-specific requirements. 10, 13

D

DAC 4, 8, 9
 Data bytes 15
 Data rates 4, 8, 14
 Debouncing functions 12, 14
 Decimation. 8
 Default setting state. 11
 Default values 11
 Development boards 3, 4
 Diagnostics 10
 Digital filters 2, 7, 9
 Digital gain stages 9
 Digital I/O pins 14
 Digital Loop Carrier Systems. 18
 Digital loops 4
 Digital-to-analog converter 9
 Discrete filters 2
 DLC 18
 Driving capability 4, 13
 DSP core 4
 DTMF. 4, 7, 10
 Dynamic gain. 4
 Dynamic range 9

E		ISDN-U transceiver	19
EASY 2466 Tool Package	25	ITU-T	4, 10
Echo signal	10	K	
Expander	10	Key Systems	17
Expansion	8	K-parameters.	22
Extended temperature range	2	L	
External components	3, 13	Level adjustments	7, 9, 24
F		Level metering function	4, 7, 10
Fiber links	18	Line characterization	10
Fiber-to-the-Curb (FTTC) Systems.	20	Linearity	4, 9
Filter blocks.	9	Linecard functions	17
Filter characteristics	7	Linecards.	3
Four-channel codec filter	3	Logic symbol	5
Frame	14	Loop filters	7, 10
Frequency response.	4, 10, 24	M	
Frequency response corrections	7, 24	Manufacturing test	4
Functional blocks	9	Master clock	5
Functional tests.	10	Microcontroller interface	7, 12, 13, 14
G		Mixed-signal CMOS process.	2
Gain	4	MUSAC-A	17
Ground-key detection	7	O	
H		On-/off-hook detection.	7, 13
Hardware Reference Manual	1	Operating state	12
HW reset.	11	Optical fiber	20
I		Optimization.	24
Identification byte	15	Other SICOFI devices	1
IEC-Q	19	Out-of-band signals	13
Impedance matching	2, 4, 7, 8, 10, 24	P	
Impedance synthesis	10	Package.	4
INT12	14	PBX	2, 16
INT34	14	PCM compression	8
Integrated DSP	2	PCM highways.	2, 8
Interface descriptions	13	PCM interface	3, 5, 8, 13, 14
Interpolation	8	PCM4.	19, 25
Interrupt outputs	5, 13, 14		

PEB 2266	1	Serial data transfer	15
P-MQFP-64.	4	Serial microcontroller interface	5, 14
Polling.	14	Serial read or write access	15
Power dissipation	11	Sigma-delta A/D and D/A converter	8, 9
Power down	12	Signal flow	8
Power management	11	Signal reflections	7
Power supply	6	Signaling changes	14
Power up.	12	Signaling interface	5, 7, 12, 13, 14
Power-saving mode	11, 12	Signaling outputs	12
Primary rate	18	SLIC.	3, 7, 13
Private branch exchanges	2	Small PBX	17
Product Brief.	1	Software configurable	3
Programmable codecs	3	Standard temperature range	2
Programmable filters.	12	Standby state.	12
Programmer's Reference Manual.	1	Subscriber line interface circuits	3, 7
PSB 2132	1	Subscriber loops	16
PSB 2134	1	Supply voltage.	4, 6
PSPICE®	23	Support tools	4
PTT specifications	24	Switching	17
		System diagnostics	4
 Q			
QSICOS	3, 4, 7, 22, 24		
Quad SICOFI coefficient software	22		
 R			
Radio-in-the-Loop Systems	21		
Read commands.	15		
Read or write acces	15		
Remote terminal	18, 19		
Reset	5, 11		
RESET bit.	11		
RESET#	11, 12		
Resolution.	9		
Return loss	24		
Ringing signals	7, 14		
RITL	21		
 S			
Sample rate conversion	8		
Sampling slope	14		
		T	
		Target hardware	25
		Teletax filters	13
		Teletax pulses	13
		Test features	3
		Test modes	12
		Test relays	7, 14
		Time slots	2, 14
		Tip/ring.	16, 19, 20, 21
		Tone generators	4, 7, 10, 12, 24
		Traditional analog linecard	2
		Transformers	4
		Transhybrid balancing.	2, 4, 7, 8, 10, 24
		Transhybrid loss	7, 24
		Transmission characteristics	2, 7
		Transmission performance	9
		Transmission requirements	2
		Transmit control output pins	14
		Trunk line interfaces	16, 17
		Two-channel codec filter	3

Typical applications6, 16

V

Voice channels14

Voice transmission12

W

Website.....1

Infineon goes for Business Excellence

“Business excellence means intelligent approaches and clearly defined processes, which are both constantly under review and ultimately lead to good operating results.

Better operating results and business excellence mean less idleness and wastefulness for all of us, more professional success, more accurate information, a better overview and, thereby, less frustration and more satisfaction.”

Dr. Ulrich Schumacher

<http://www.infineon.com>

Published by Infineon Technologies AG