PF0121

MOS FET Power Amplifier Module for GSM Mobile Phone

HITACHI

ADE-208-097A (Z)
2nd Edition
July 1996

Application

For GSM CLASS2 890 to 915 MHz

Features

- Low power control current: 0.9 mA Typ
- High speed switching: 1.5 μ sec Typ
- Wide power control range: 100 dB Typ

Pin Arrangement

• RF-B2

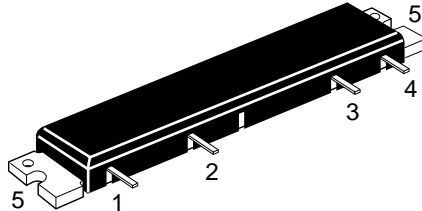

- 1: Pin
- 2: V_{APC}
- 3: V_{DD}
- 4: Pout
- 5: GND

Internal Diagram and External Circuit

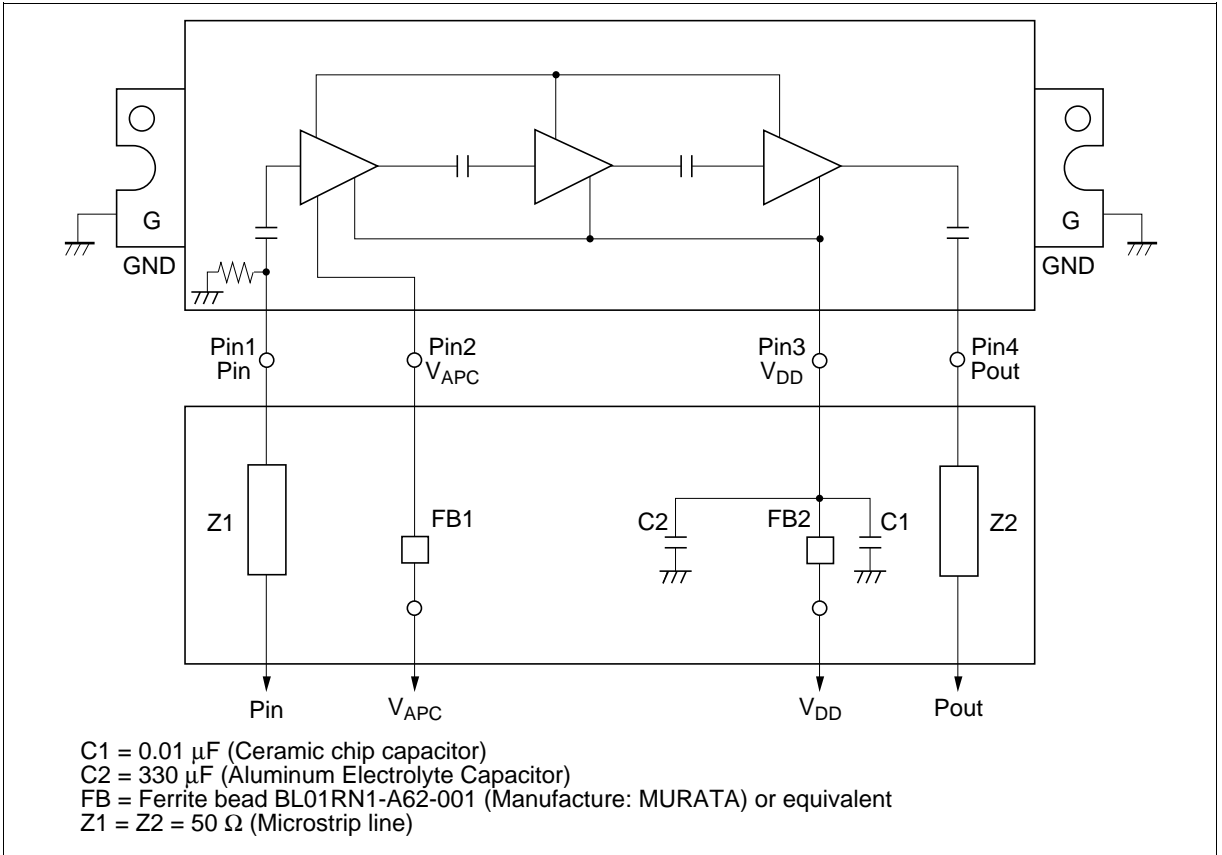

Absolute Maximum Ratings ($T_c = 25^\circ\text{C}$)

Item	Symbol	Rating	Unit
Supply voltage	V_{DD}	17	V
Supply current	I_{DD}	6	A
APC voltage	V_{APC}	8	V
Input power	Pin	20	mW
Operating case temperature	T_c (op)	-30 to +110	$^\circ\text{C}$
Storage temperature	T_{stg}	-40 to +110	$^\circ\text{C}$

Electrical Characteristics ($T_c = 25^\circ\text{C}$)

Item	Symbol	Min	Typ	Max	Unit	Test Condition
Drain cutoff current	I_{DS}	—	—	500	μA	$V_{DD} = 17\text{ V}, V_{APC} = 0\text{ V}$
Total efficiency	η_T	30	35	—	%	$P_{in} = 2\text{ mW}, V_{DD} = 12.5\text{ V},$ $P_{out} = 13\text{ W (at APC controlled),}$
2nd harmonic distortion	2nd H.D.	—	-50	-40	dBc	$R_L = R_g = 50\ \Omega, T_c = 25^\circ\text{C}$
3rd harmonic distortion	3rd H.D.	—	-55	-45	dBc	
Input VSWR	VSWR (in)	—	2	3	—	
Output power (1)	$P_{out} (1)$	17	23	—	W	$P_{in} = 2\text{ mW}, V_{DD} = 12.5\text{ V}, V_{APC} = 7\text{ V},$ $R_L = R_g = 50\ \Omega, T_c = 25^\circ\text{C}$
Output power (2)	$P_{out} (2)$	9	12	—	W	$P_{in} = 2\text{ mW}, V_{DD} = 10.3\text{V}, V_{APC} = 7\text{ V},$ $R_L = R_g = 50\ \Omega, T_c = 80^\circ\text{C}$
Isolation	—	—	-60	-40	dBm	$P_{in} = 2\text{ mW}, V_{DD} = 12.5\text{ V}, V_{APC} = 0.5\text{ V},$ $R_L = R_g = 50\ \Omega, T_c = 25^\circ\text{C}$
Switching time	t_r, t_f	—	1.5	2	μs	$P_{in} = 2\text{ mW}, V_{DD} = 12.5\text{ V}, P_{out} = 13\text{ W},$ $R_L = R_g = 50\ \Omega, T_c = 25^\circ\text{C}$
Stability	—	No parasitic oscillation			—	$P_{in} = 2\text{ mW}, V_{DD} = 12.5\text{ V},$ $P_{out} \leq 13\text{ W (at APC controlled),}$ $R_g = 50\ \Omega, T_c = 25^\circ\text{C},$ Output VSWR = 20:1 All phases

Test System Diagram

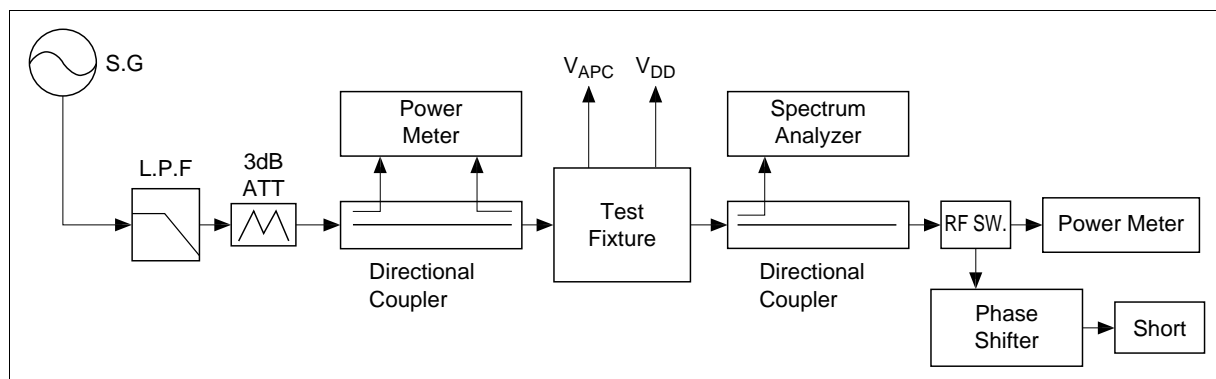

Switching Time Test Diagram

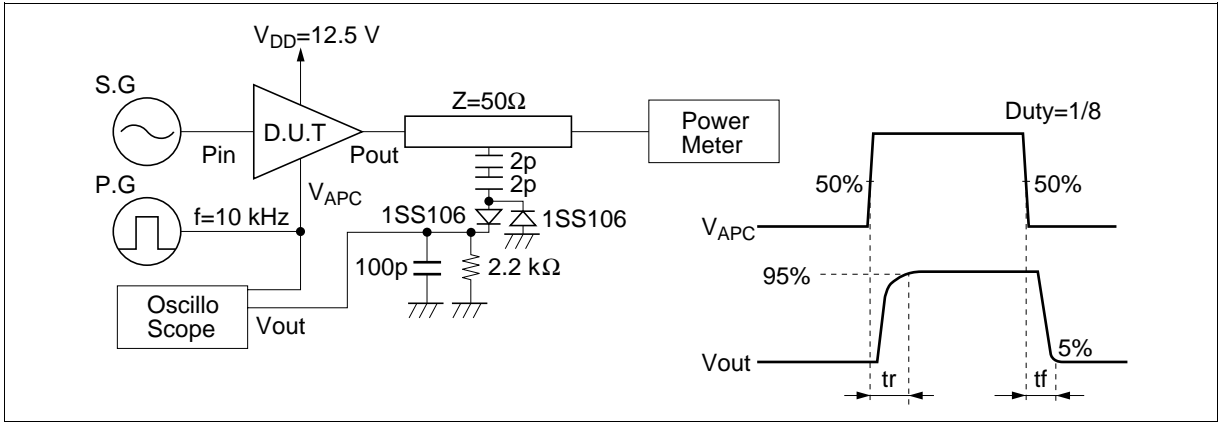

Test Fixture Pattern

Unit: mm

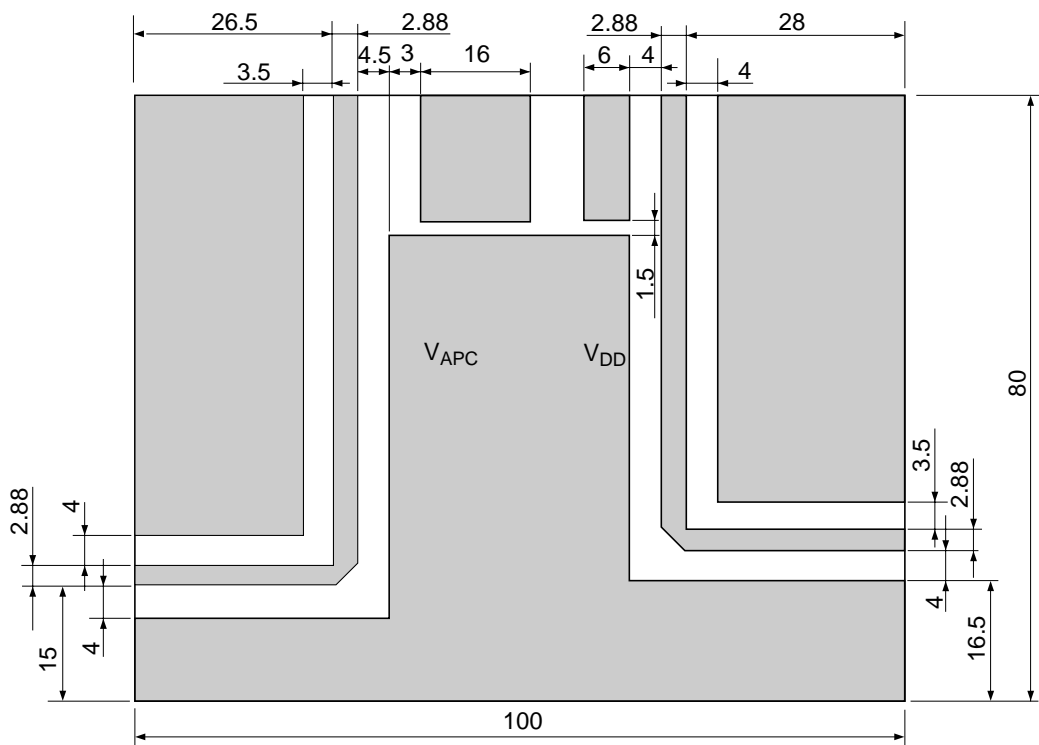

Grass Epoxy Double sided PCB
 (t = 1.6 mm, εr = 4.8)
 C1=0.01μF (Ceramic Chip Capacitor)
 C2=330μF (Aluminum Electrolyte Capacitor)
 L1=L2 : BLO2RN1-R62 (Manufacturer : MURATA) or equivalent (Ferrite Bead Inductor)
 The coefficient of RF line loss in the P.C.B is showed bellow.
 $1 / (S_{21})^2 = 1 / (0.9805)^2 = 1.068$

Mechanical Characteristics

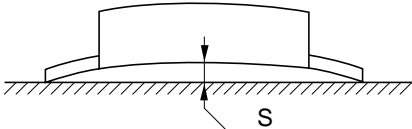
Item	Conditions	Spec
Torque for screw up the heatsink flange	M3 Screw Bolts	4 to 6 kg•cm
Warp size of the heatsink flange: S		S = 0 +0.3/-0 mm

Note for Use

- Unevenness and distortion at the surface of the heatsink attached module should be less than 0.05 mm.
- It should not be existed any dust between module and heatsink.
- MODULE should be separated from PCB less than 1.5 mm.
Soldering temperature and soldering time should be less than 230°C, 10 sec.
(Soldering position spaced from the root point of the lead frame: 2 mm)
- Recommendation of thermal joint compounds is TYPE G746.
(Manufacturer: Shin-Etsu Chemical, Co., Ltd.)
- To protect devices from electro-static damage, soldering iron, measuring-equipment and human body etc. should be grounded.
- Torque for screw up the heatsink flange should be 4 to 6 kg · cm with M3 screw bolts.
- Don't solder the flange directly.
- It should make the lead frame as straight as possible.
- The module should be screwed up before lead soldering.
- It should not be given mechanical and thermal stress to lead and flange of the module.
- When the external parts (Isolator, Duplexer, etc.) of the module are changed, the electrical characteristics should be evaluated enough.
- Don't washing the module except lead pins.
- To get good stability, ground impedance between the module GND flange and PCB GND pattern should be designed as low as possible.

Characteristic Curves

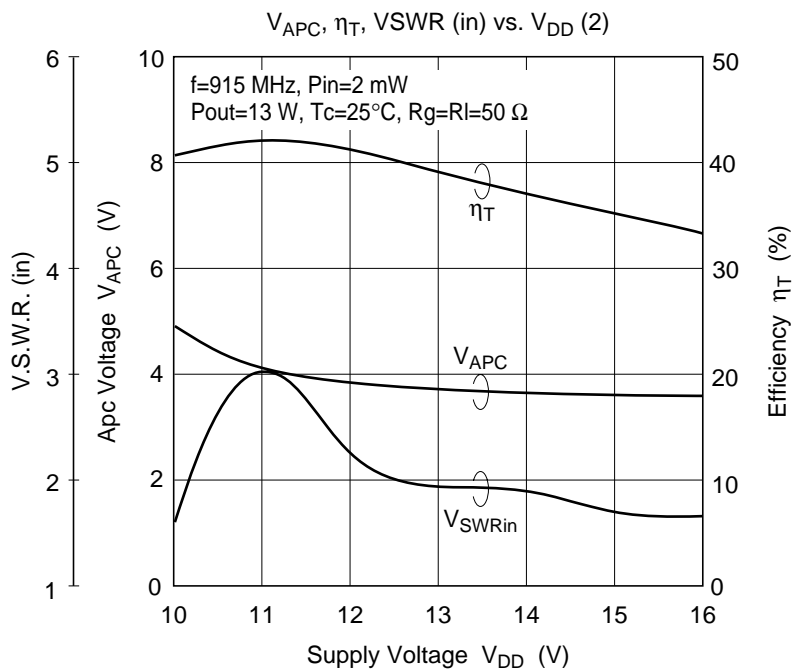
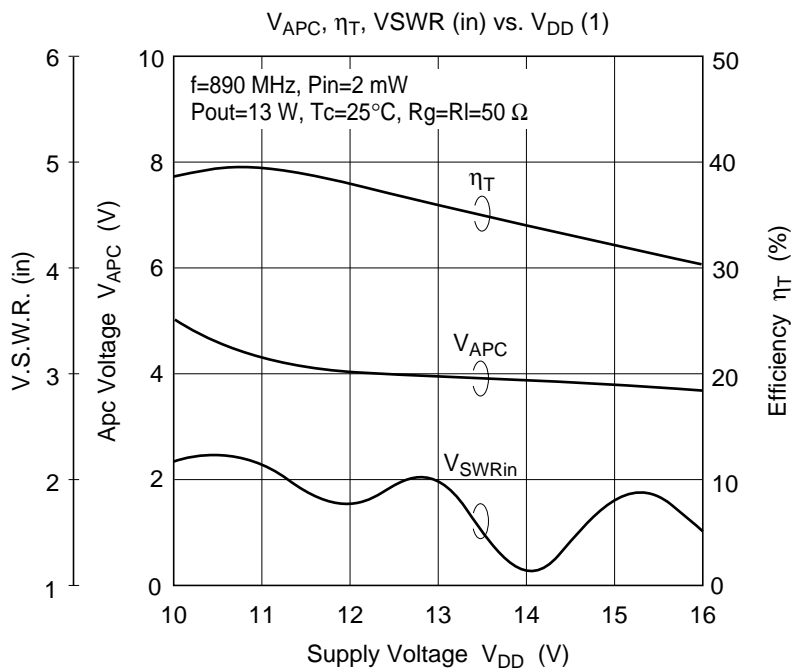

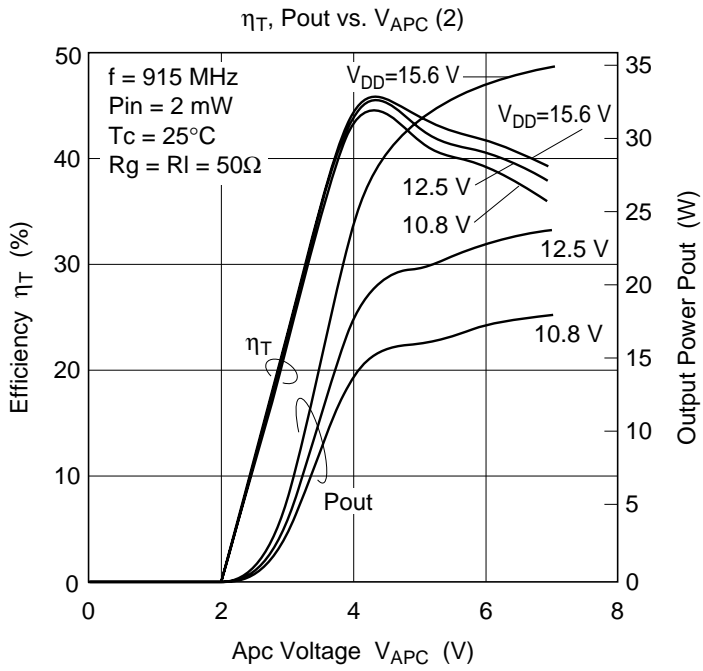
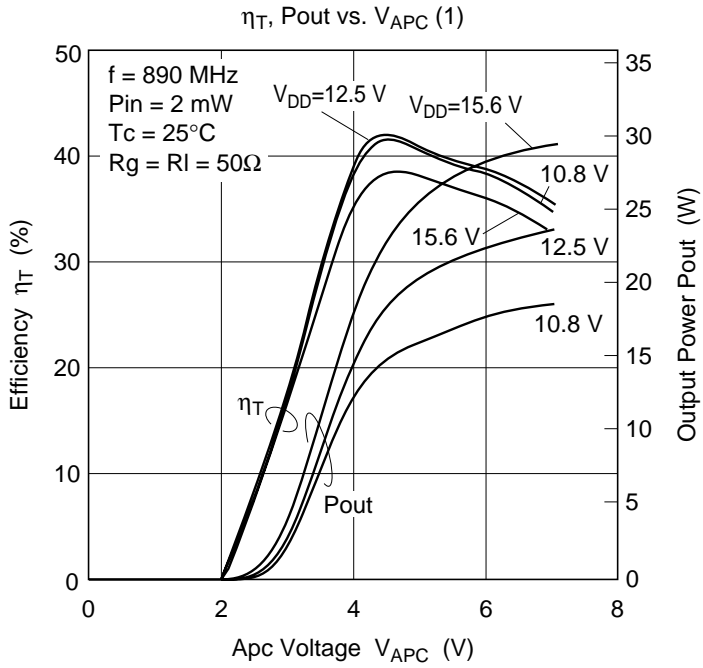

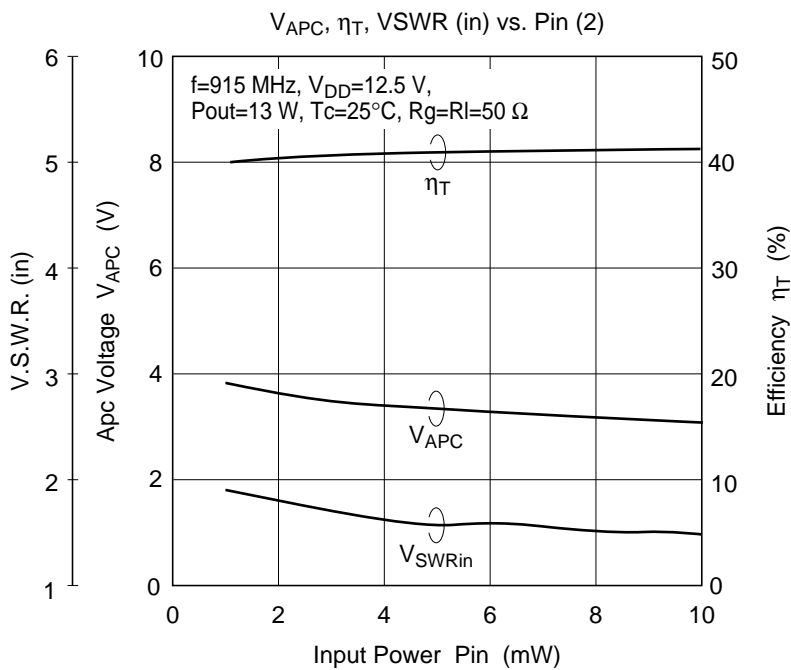
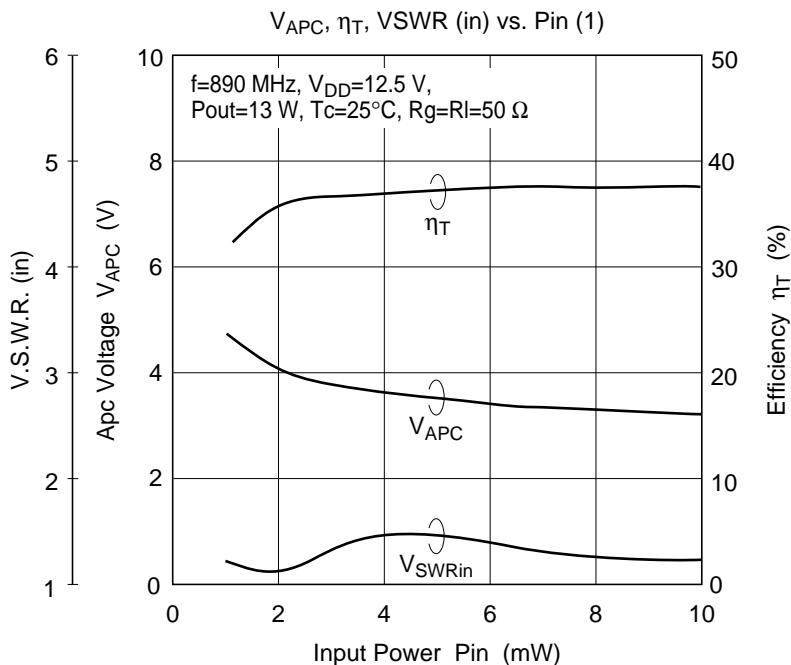

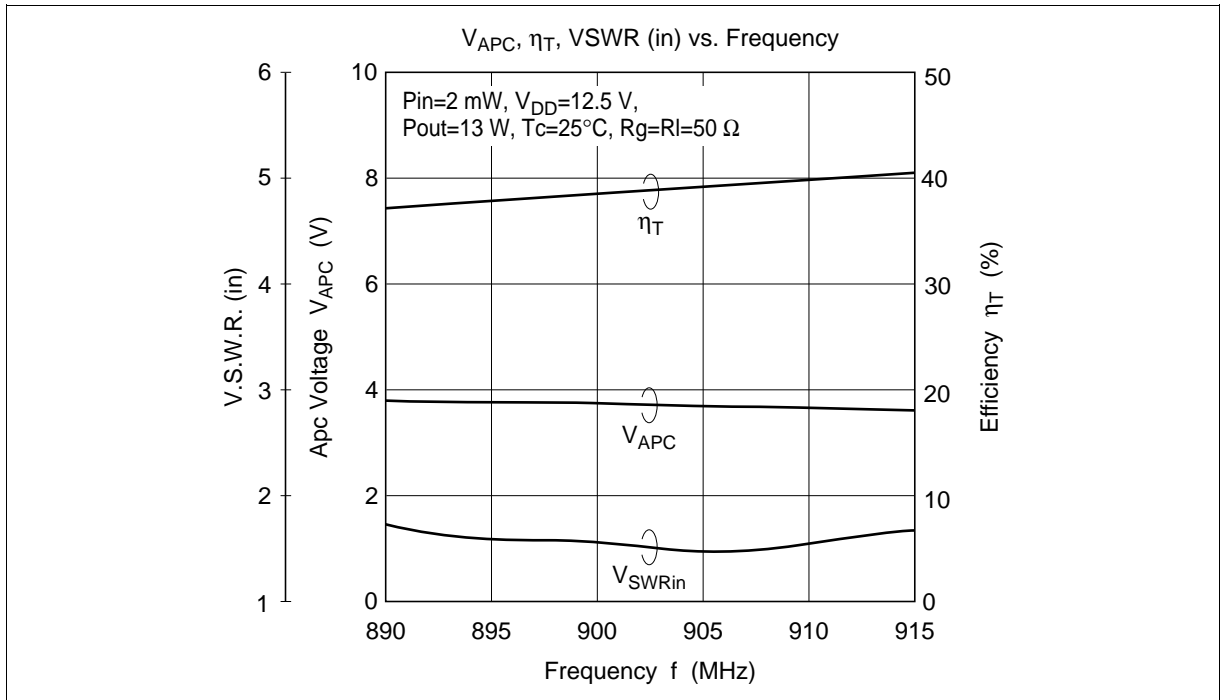

Package Dimensions

Unit: mm

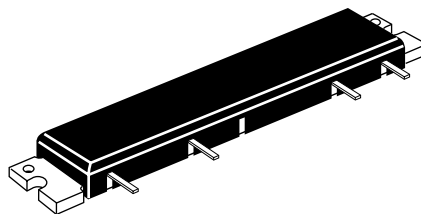
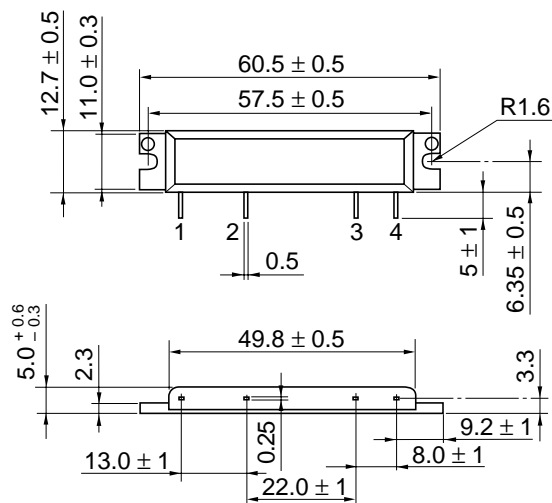

Hitachi Code	RF-B2
JEDEC	—
EIAJ	—
Weight (reference value)	16 g

Cautions

1. Hitachi neither warrants nor grants licenses of any rights of Hitachi's or any third party's patent, copyright, trademark, or other intellectual property rights for information contained in this document. Hitachi bears no responsibility for problems that may arise with third party's rights, including intellectual property rights, in connection with use of the information contained in this document.
2. Products and product specifications may be subject to change without notice. Confirm that you have received the latest product standards or specifications before final design, purchase or use.
3. Hitachi makes every attempt to ensure that its products are of high quality and reliability. However, contact Hitachi's sales office before using the product in an application that demands especially high quality and reliability or where its failure or malfunction may directly threaten human life or cause risk of bodily injury, such as aerospace, aeronautics, nuclear power, combustion control, transportation, traffic, safety equipment or medical equipment for life support.
4. Design your application so that the product is used within the ranges guaranteed by Hitachi particularly for maximum rating, operating supply voltage range, heat radiation characteristics, installation conditions and other characteristics. Hitachi bears no responsibility for failure or damage when used beyond the guaranteed ranges. Even within the guaranteed ranges, consider normally foreseeable failure rates or failure modes in semiconductor devices and employ systemic measures such as fail-safes, so that the equipment incorporating Hitachi product does not cause bodily injury, fire or other consequential damage due to operation of the Hitachi product.
5. This product is not designed to be radiation resistant.
6. No one is permitted to reproduce or duplicate, in any form, the whole or part of this document without written approval from Hitachi.
7. Contact Hitachi's sales office for any questions regarding this document or Hitachi semiconductor products.

HITACHI

Hitachi, Ltd.

Semiconductor & Integrated Circuits.
Nippon Bldg., 2-6-2, Ohte-machi, Chiyoda-ku, Tokyo 100-0004, Japan
Tel: Tokyo (03) 3270-2111 Fax: (03) 3270-5109

URL North America : <http://semiconductor.hitachi.com/>
Europe : <http://www.hitachi-eu.com/hel/ecg>
Asia (Singapore) : <http://www.has.hitachi.com.sg/grp3/sicd/index.htm>
Asia (Taiwan) : http://www.hitachi.com.tw/E/Product/SICD_Frame.htm
Asia (HongKong) : <http://www.hitachi.com.hk/eng/bo/grp3/index.htm>
Japan : <http://www.hitachi.co.jp/Sicd/indx.htm>

For further information write to:

Hitachi Semiconductor
(America) Inc.
179 East Tasman Drive,
San Jose, CA 95134
Tel: <1> (408) 433-1990
Fax: <1> (408) 433-0223

Hitachi Europe GmbH
Electronic components Group
Dornacher Straße 3
D-85622 Feldkirchen, Munich
Germany
Tel: <49> (89) 9 9180-0
Fax: <49> (89) 9 29 30 00

Hitachi Europe Ltd.
Electronic Components Group.
Whitebrook Park
Lower Cookham Road
Maidenhead
Berkshire SL6 8YA, United Kingdom
Tel: <44> (1628) 585000
Fax: <44> (1628) 778322

Hitachi Asia Pte. Ltd.
16 Collyer Quay #20-00
Hitachi Tower
Singapore 049318
Tel: 535-2100
Fax: 535-1533

Hitachi Asia Ltd.
Taipei Branch Office
3F, Hung Kuo Building, No.167,
Tun-Hwa North Road, Taipei (105)
Tel: <886> (2) 2718-3666
Fax: <886> (2) 2718-8180

Hitachi Asia (Hong Kong) Ltd.
Group III (Electronic Components)
7/F., North Tower, World Finance Centre,
Harbour City, Canton Road, Tsim Sha Tsui,
Kowloon, Hong Kong
Tel: <852> (2) 735 9218
Fax: <852> (2) 730 0281
Telex: 40815 HITEC HX

Copyright ' Hitachi, Ltd., 1999. All rights reserved. Printed in Japan.

HITACHI