

# PF610HV

## Dual N-Channel Enhancement Mode MOSFET

### PRODUCT SUMMARY

$V_{(BR)DSS}$	$R_{DS(ON)}$	$I_D$
100V	0.7Ω @ $V_{GS} = 10V$	1A

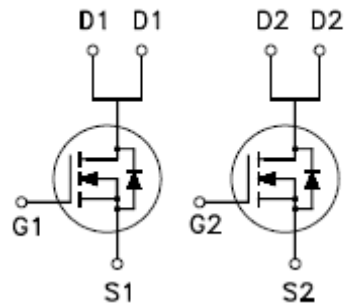
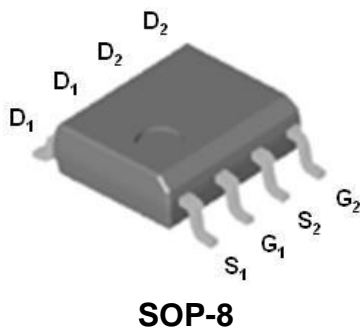

### ABSOLUTE MAXIMUM RATINGS ( $T_A = 25\text{ °C}$ Unless Otherwise Noted)

PARAMETERS/TEST CONDITIONS		SYMBOL	LIMITS	UNITS
Drain-Source Voltage		$V_{DS}$	100	V
Gate-Source Voltage		$V_{GS}$	±20	
Continuous Drain Current	$T_A = 25\text{ °C}$	$I_D$	1	A
	$T_A = 70\text{ °C}$		0.8	
Pulsed Drain Current <sup>1</sup>		$I_{DM}$	4	
Avalanche Current		$I_{AS}$	3.9	
Avalanche Energy	$L = 1\text{mH}$	$E_{AS}$	7.6	mJ
Power Dissipation	$T_A = 25\text{ °C}$	$P_D$	1.6	W
	$T_A = 70\text{ °C}$		1	
Operating Junction & Storage Temperature Range		$T_j, T_{stg}$	-55 to 150	°C

### THERMAL RESISTANCE RATINGS

THERMAL RESISTANCE	SYMBOL	TYPICAL	MAXIMUM	UNITS
Junction-to-Ambient	$R_{\theta JA}$		75	°C / W

<sup>1</sup>Pulse width limited by maximum junction temperature.

# PF610HV

## Dual N-Channel Enhancement Mode MOSFET

### ELECTRICAL CHARACTERISTICS (T<sub>J</sub> = 25 °C, Unless Otherwise Noted)

PARAMETER	SYMBOL	TEST CONDITIONS	LIMITS			UNITS
			MIN	TYP	MAX	
<b>STATIC</b>						
Drain-Source Breakdown Voltage	V <sub>(BR)DSS</sub>	V <sub>GS</sub> = 0V, I <sub>D</sub> = 250μA	100			V
Gate Threshold Voltage	V <sub>GS(th)</sub>	V <sub>DS</sub> = V <sub>GS</sub> , I <sub>D</sub> = 250μA	1	1.8	3	V
Gate-Body Leakage	I <sub>GSS</sub>	V <sub>DS</sub> = 0V, V <sub>GS</sub> = ±20V			±100	nA
Zero Gate Voltage Drain Current	I <sub>DSS</sub>	V <sub>DS</sub> = 80V, V <sub>GS</sub> = 0V			1	μA
		V <sub>DS</sub> = 80V, V <sub>GS</sub> = 0V, T <sub>J</sub> = 70 °C			10	
On-State Drain Current <sup>1</sup>	I <sub>D(ON)</sub>	V <sub>DS</sub> = 5V, V <sub>GS</sub> = 10V	3.9			A
Drain-Source On-State Resistance <sup>1</sup>	R <sub>DS(ON)</sub>	V <sub>GS</sub> = 10V, I <sub>D</sub> = 0.9A		0.5	0.7	Ω
		V <sub>GS</sub> = 4.5V, I <sub>D</sub> = 0.5A		0.6	0.9	
Forward Transconductance <sup>1</sup>	g <sub>fs</sub>	V <sub>DS</sub> = 5V, I <sub>D</sub> = 0.9A		2		S
<b>DYNAMIC</b>						
Input Capacitance	C <sub>iss</sub>	V <sub>GS</sub> = 0V, V <sub>DS</sub> = 25V, f = 1MHz		240		pF
Output Capacitance	C <sub>oss</sub>			60		
Reverse Transfer Capacitance	C <sub>riss</sub>			18		
Gate Resistance	R <sub>g</sub>	V <sub>GS</sub> = 0V, V <sub>DS</sub> = 0V, f = 1MHz		1.7		Ω
Total Gate Charge <sup>2</sup>	Q <sub>g</sub>	V <sub>DS</sub> = 0.5V <sub>(BR)DSS</sub> , V <sub>GS</sub> = 10V, I <sub>D</sub> = 0.9A		7		nC
Gate-Source Charge <sup>2</sup>	Q <sub>gs</sub>			1.1		
Gate-Drain Charge <sup>2</sup>	Q <sub>gd</sub>			3		
Turn-On Delay Time <sup>2</sup>	t <sub>d(on)</sub>	V <sub>DS</sub> = 0.5V <sub>(BR)DSS</sub> , I <sub>D</sub> ≅ 0.9A, V <sub>GS</sub> = 10V, R <sub>G</sub> = 6Ω		18		nS
Rise Time <sup>2</sup>	t <sub>r</sub>			10		
Turn-Off Delay Time <sup>2</sup>	t <sub>d(off)</sub>			37		
Fall Time <sup>2</sup>	t <sub>f</sub>			25		
<b>SOURCE-DRAIN DIODE RATINGS AND CHARACTERISTICS(T<sub>J</sub> = 25 °C)</b>						
Continuous Current	I <sub>S</sub>				1	A
Forward Voltage <sup>1</sup>	V <sub>SD</sub>	I <sub>F</sub> = 0.9A, V <sub>GS</sub> = 0V			1.2	V
Reverse Recovery Time	t <sub>rr</sub>	I <sub>F</sub> = 1A, dI <sub>F</sub> /dt = 100A / μS		25		nS
Reverse Recovery Charge	Q <sub>rr</sub>			22		nC

<sup>1</sup>Pulse test : Pulse Width ≤ 300 μsec, Duty Cycle ≤ 2%.

<sup>2</sup>Independent of operating temperature.

# PF610HV

## Dual N-Channel Enhancement Mode MOSFET

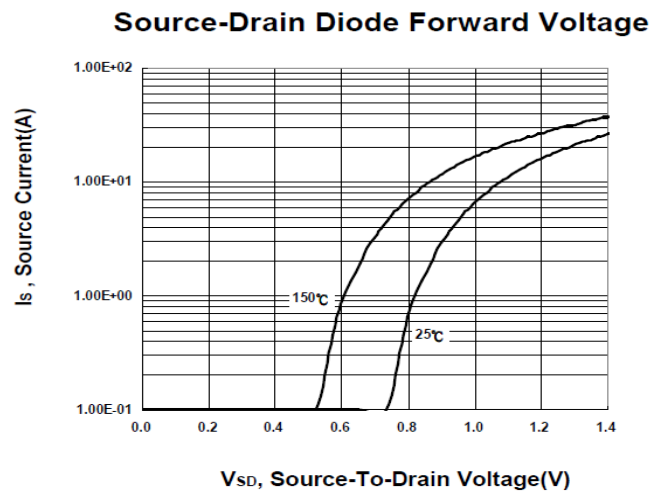
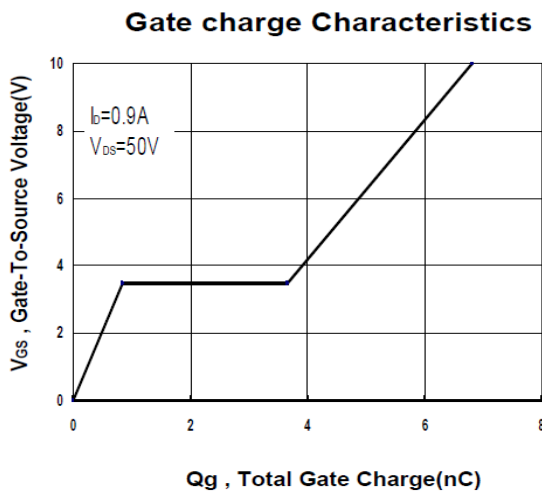
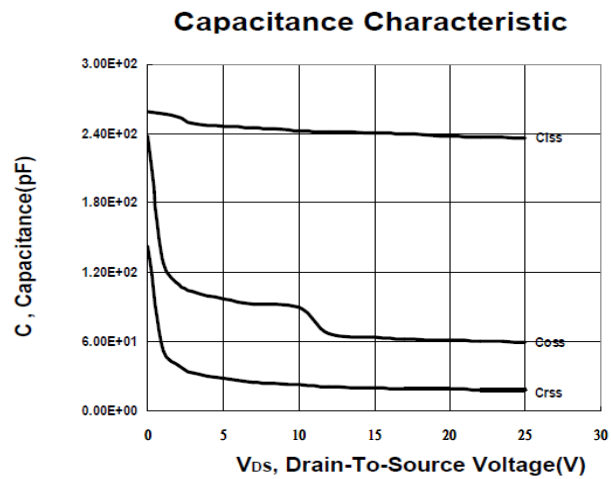
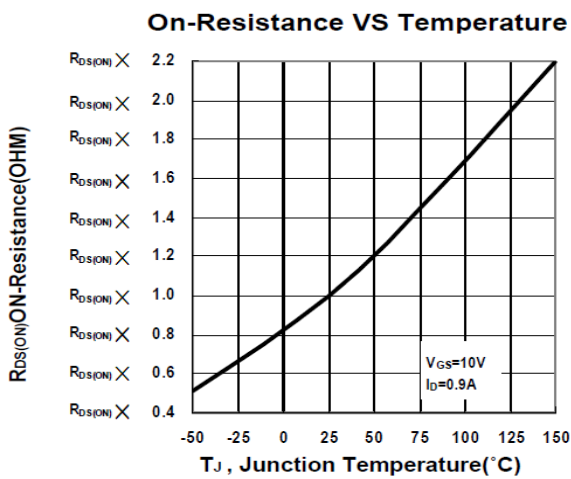
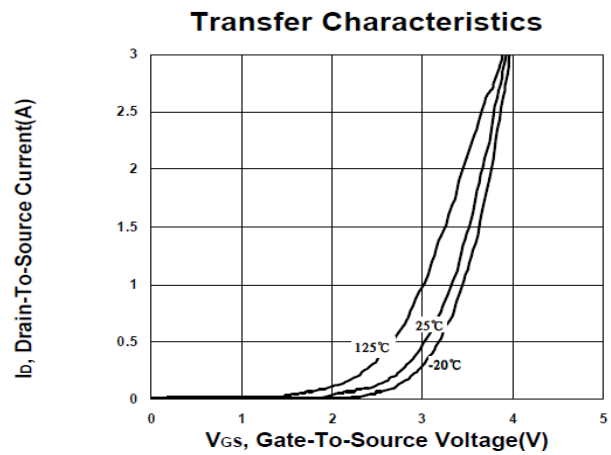
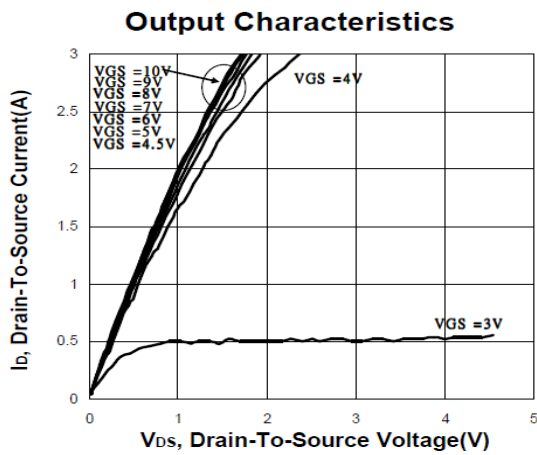

# PF610HV

## Dual N-Channel Enhancement Mode MOSFET

**Safe Operating Area**

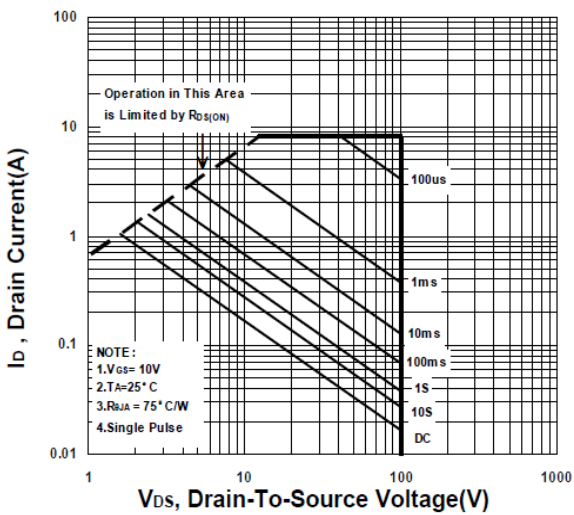

**Single Pulse Maximum Power Dissipation**

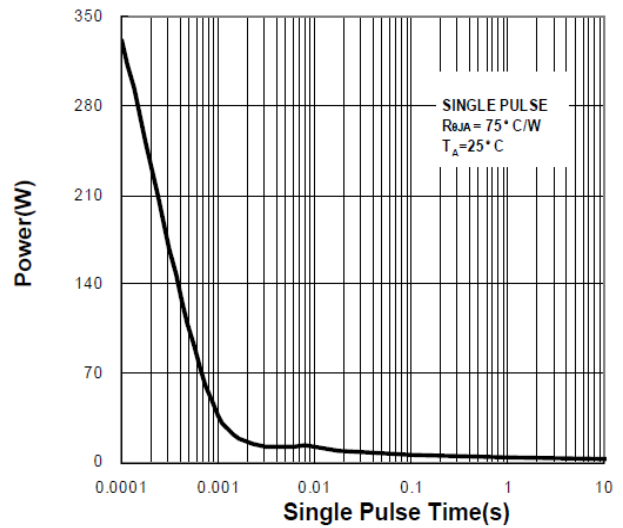

**Transient Thermal Response Curve**

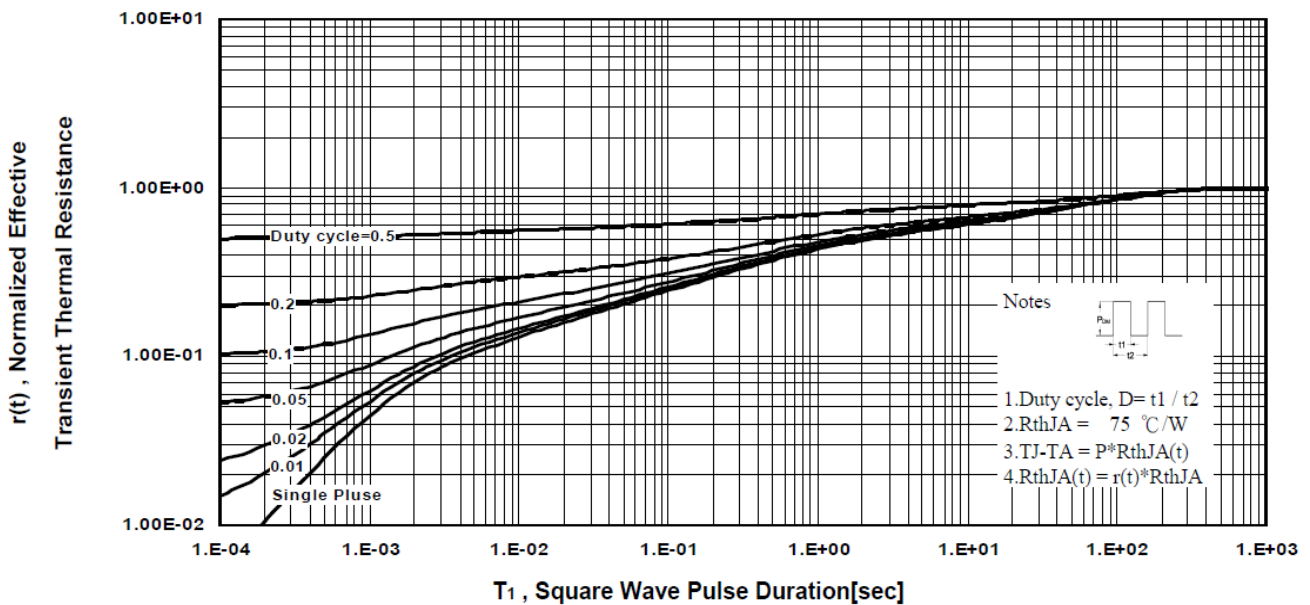

# PF610HV

## Dual N-Channel Enhancement Mode MOSFET

### Package Dimension

### SOP-8 MECHANICAL DATA

Dimension	mm			Dimension	mm		
	Min.	Typ.	Max.		Min.	Typ.	Max.
A	4.8	4.9	5.0	H	0.4	0.6	0.93
B	3.8	3.9	4.0	I	0.19	0.21	0.25
C	5.79	6.0	6.2	J	0.25	0.375	0.5
D	0.33	0.4	0.51	K	0°	3°	18°
E	1.25	1.27	1.29				
F	1.1	1.3	1.65				
G	0.05	0.15	0.25				

