

PFI10N80A/PFB10N80A

750V N-Channel MOSFET

FEATURES

- ❑ Originative New Design
- ❑ 100% EAS Test
- ❑ Rugged Gate Oxide Technology
- ❑ Extremely Low Intrinsic Capacitances
- ❑ Remarkable Switching Characteristics
- ❑ Unequalled Gate Charge : 27.5 nC (Typ.)
- ❑ Extended Safe Operating Area
- ❑ Lower $R_{DS(ON)}$: 1.15 Ω (Typ.) @ $V_{GS}=10V$

APPLICATION

- ❑ High current, High speed switching
- ❑ Suitable for power supplies, adaptors and PFC
- ❑ SMPS (Switched Mode Power Supplies)

$BV_{DSS} = 750\text{ V}$ $R_{DS(on)} = 1.15\ \Omega$ $I_D = 8.0\text{ A}$	
<p style="font-size: small;">1.Gate 2. Drain 3. Source</p>	<p style="font-size: small;">1.Gate 2. Drain 3. Source</p>

Absolute Maximum Ratings T_C=25°C unless otherwise specified

Symbol	Parameter	Value	Units
V_{DSS}	Drain-Source Voltage	750	V
I_D	Drain Current – Continuous (T _C = 25°C)	8.0	A
	Drain Current – Continuous (T _C = 100°C)	5.1	A
I_{DM}	Drain Current – Pulsed (Note 1)	32	A
V_{GS}	Gate-Source Voltage	±30	V
E_{AS}	Single Pulsed Avalanche Energy (Note 2)	700	mJ
I_{AR}	Avalanche Current (Note 1)	8.0	A
E_{AR}	Repetitive Avalanche Energy (Note 1)	17.9	mJ
dv/dt	Peak Diode Recovery dv/dt (Note 3)	4.5	V/ns
P_D	Power Dissipation (T _C = 25°C)	179	W
	– Derate above 25°C	1.43	W/°C
T _J , T _{STG}	Operating and Storage Temperature Range	-55 to +150	°C
T _L	Maximum lead temperature for soldering purposes, 1/8" from case for 5 seconds	300	°C

* Drain current limited by maximum junction temperature

Thermal Resistance Characteristics

Symbol	Parameter	Typ	Max	Units
$R_{\theta JC}$	Thermal Resistance, Junction-to-Case	--	0.7	°C/W
$R_{\theta CS}$	Thermal Resistance, Case-to-Sink	--	0.5	
$R_{\theta JA}$	Thermal Resistance, Junction-to-Ambient	--	62.5	

Electrical Characteristics $T_C=25\text{ }^\circ\text{C}$ unless otherwise specified

Symbol	Parameter	Test Conditions	Min	Typ	Max	Units
On Characteristics						
V_{GS}	Gate Threshold Voltage	$V_{DS} = V_{GS}, I_D = 250\ \mu\text{A}$	2.5	--	4.5	V
$R_{DS(ON)}$	Static Drain-Source On-Resistance	$V_{GS} = 10\ \text{V}, I_D = 4.0\ \text{A}$	--	1.15	1.30	Ω
Off Characteristics						
BV_{DSS}	Drain-Source Breakdown Voltage	$V_{GS} = 0\ \text{V}, I_D = 250\ \mu\text{A}$	750	--	--	V
$\Delta BV_{DSS} / \Delta T_J$	Breakdown Voltage Temperature Coefficient	$I_D = 250\ \mu\text{A}$, Referenced to $25\text{ }^\circ\text{C}$	--	0.5	--	$\text{V}/^\circ\text{C}$
I_{DSS}	Zero Gate Voltage Drain Current	$V_{DS} = 750\ \text{V}, V_{GS} = 0\ \text{V}$	--	--	10	μA
		$V_{DS} = 600\ \text{V}, T_C = 125\text{ }^\circ\text{C}$	--	--	100	μA
I_{GSSF}	Gate-Body Leakage Current, Forward	$V_{GS} = 30\ \text{V}, V_{DS} = 0\ \text{V}$	--	--	100	nA
I_{GSSR}	Gate-Body Leakage Current, Reverse	$V_{GS} = -30\ \text{V}, V_{DS} = 0\ \text{V}$	--	--	-100	nA
Dynamic Characteristics						
C_{iss}	Input Capacitance	$V_{DS} = 25\ \text{V}, V_{GS} = 0\ \text{V},$ $f = 1.0\ \text{MHz}$	--	1230	1600	pF
C_{oss}	Output Capacitance		--	135	176	pF
C_{rss}	Reverse Transfer Capacitance		--	10	13	pF
Switching Characteristics						
$t_{d(on)}$	Turn-On Time	$V_{DS} = 375\ \text{V}, I_D = 8.0\ \text{A},$ $R_G = 25\ \Omega$ (Note 4,5)	--	24	48	ns
t_r	Turn-On Rise Time		--	15	30	ns
$t_{d(off)}$	Turn-Off Delay Time		--	80	160	ns
t_f	Turn-Off Fall Time		--	20	40	ns
Q_g	Total Gate Charge	$V_{DS} = 600\ \text{V}, I_D = 8.0\ \text{A},$ $V_{GS} = 10\ \text{V}$ (Note 4,5)	--	27.5	35	nC
Q_{gs}	Gate-Source Charge		--	7	--	nC
Q_{gd}	Gate-Drain Charge		--	10	--	nC
Source-Drain Diode Maximum Ratings and Characteristics						
I_S	Continuous Source-Drain Diode Forward Current		--	--	8.0	A
I_{SM}	Pulsed Source-Drain Diode Forward Current		--	--	32	
V_{SD}	Source-Drain Diode Forward Voltage	$I_S = 8.0\ \text{A}, V_{GS} = 0\ \text{V}$	--	--	1.5	V
t_{rr}	Reverse Recovery Time	$I_S = 8.0\ \text{A}, V_{GS} = 0\ \text{V}$ $di_F/dt = 100\ \text{A}/\mu\text{s}$ (Note 4)	--	460	--	ns
Q_{rr}	Reverse Recovery Charge		--	4.6	--	μC

Notes ;

1. Repetitive Rating : Pulse width limited by maximum junction temperature
2. $I_{AS}=8.0\text{A}, V_{DD}=50\text{V}, R_G=25\Omega$, Starting $T_J=25\text{ }^\circ\text{C}$
3. $I_{SD}\leq 8.0\text{A}, di/dt\leq 300\text{A}/\mu\text{s}, V_{DD}\leq BV_{DSS}$, Starting $T_J=25\text{ }^\circ\text{C}$
4. Pulse Test : Pulse Width $\leq 300\mu\text{s}$, Duty Cycle $\leq 2\%$
5. Essentially Independent of Operating Temperature

Typical Characteristics

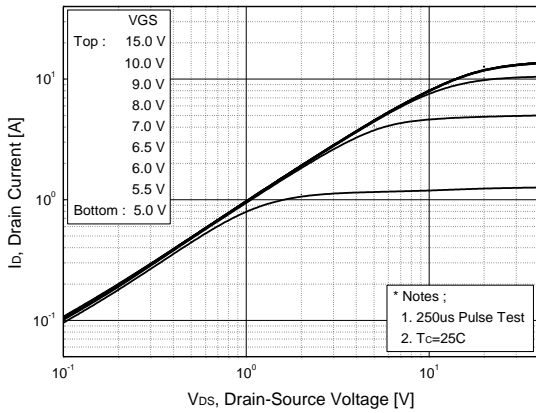

Figure 1. On Region Characteristics

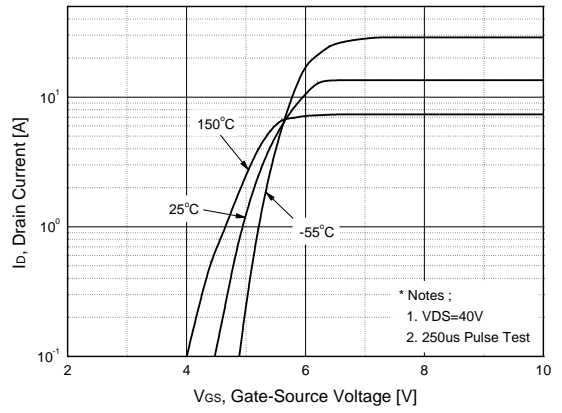

Figure 2. Transfer Characteristics

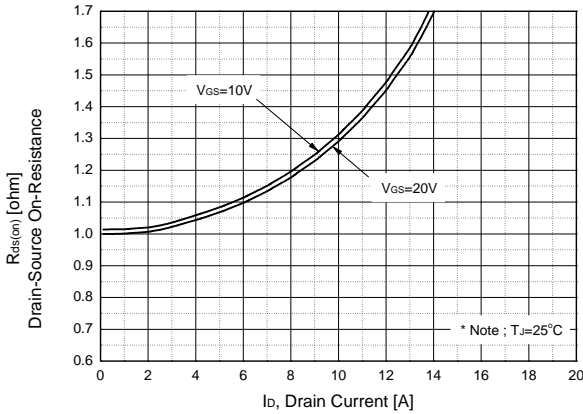

Figure 3. On Resistance Variation vs Drain Current and Gate Voltage

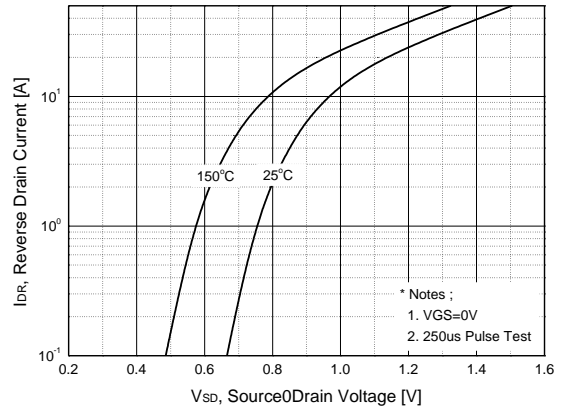

Figure 4. Body Diode Forward Voltage Variation with Source Current and Temperature

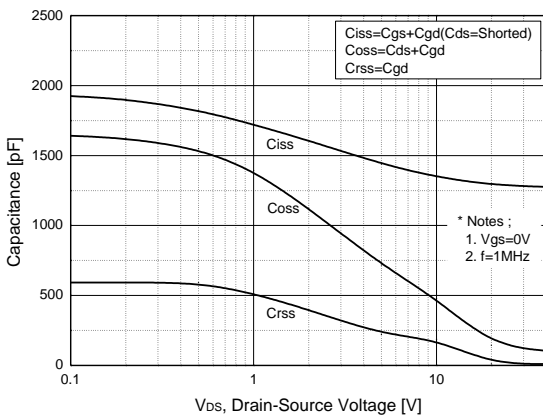

Figure 5. Capacitance Characteristics

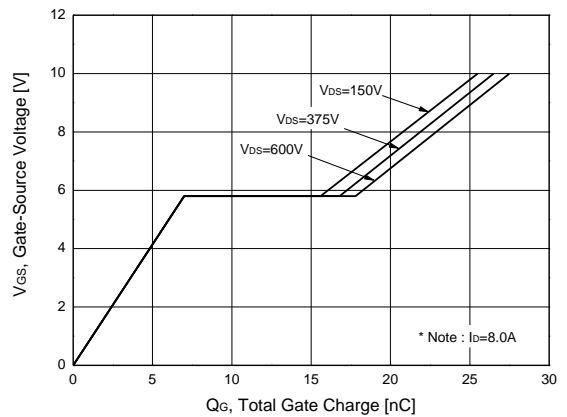

Figure 6. Gate Charge Characteristics

Typical Characteristics (continued)

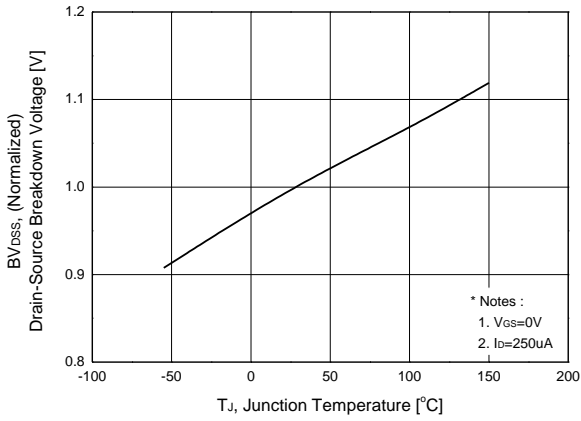

Figure 7. Breakdown Voltage Variation vs Temperature

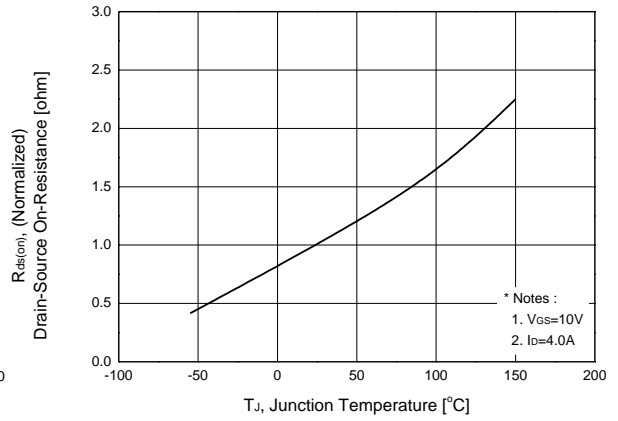

Figure 8. On-Resistance Variation vs Temperature

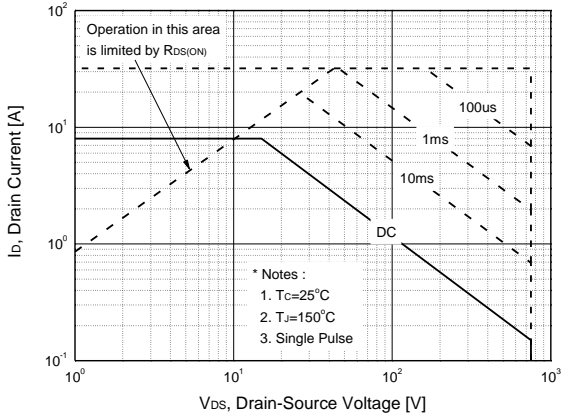

Figure 9. Maximum Safe Operating Area

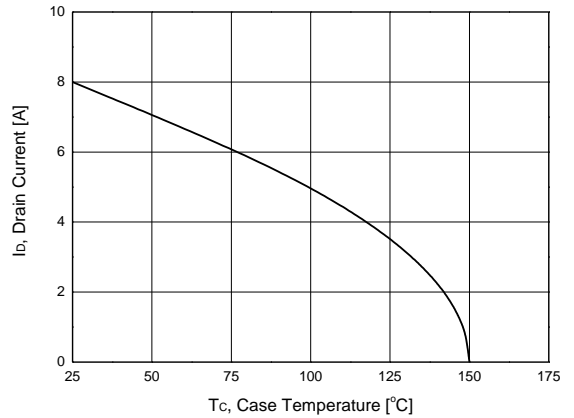

Figure 10. Maximum Drain Current vs Case Temperature

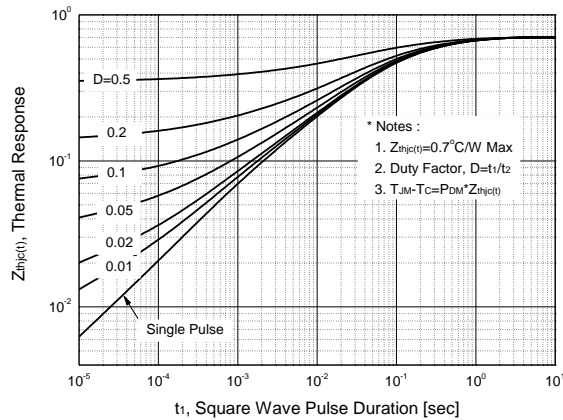

Figure 11. Transient Thermal Response Curve

Characteristics Test Circuit & Waveform

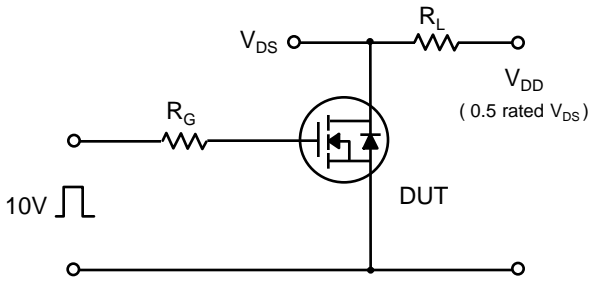

Fig 14. Resistive Switching Test Circuit & Waveforms

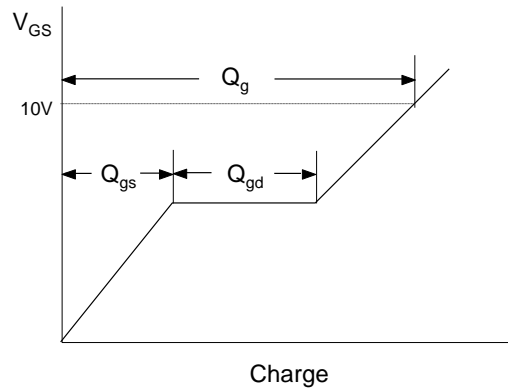
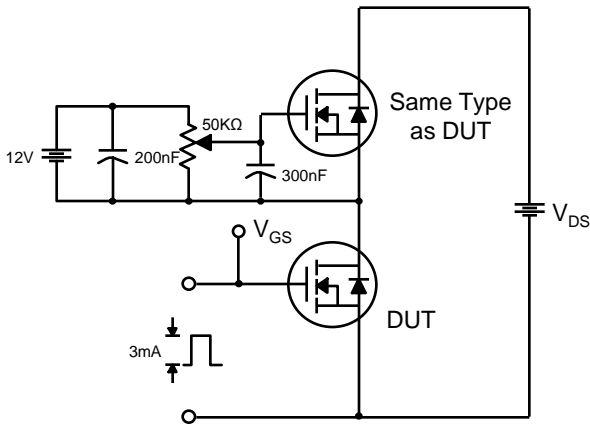

Fig 15. Gate Charge Test Circuit & Waveform

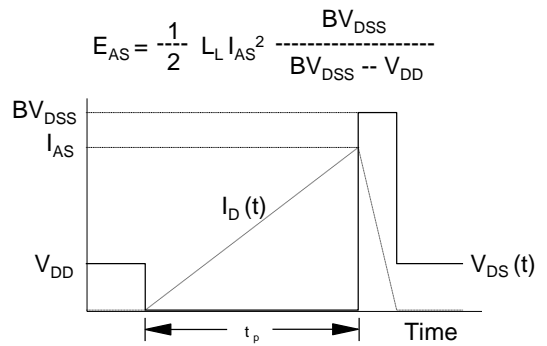
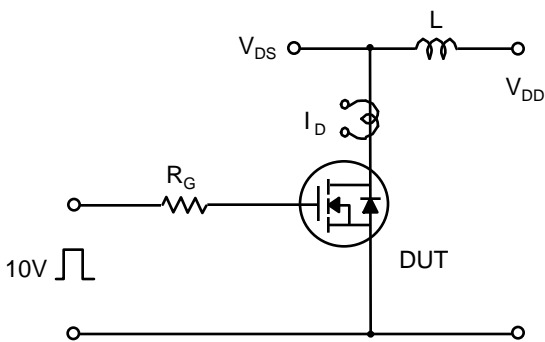

Fig 16. Unclamped Inductive Switching Test Circuit & Waveforms

Characteristics Test Circuit & Waveform (continued)

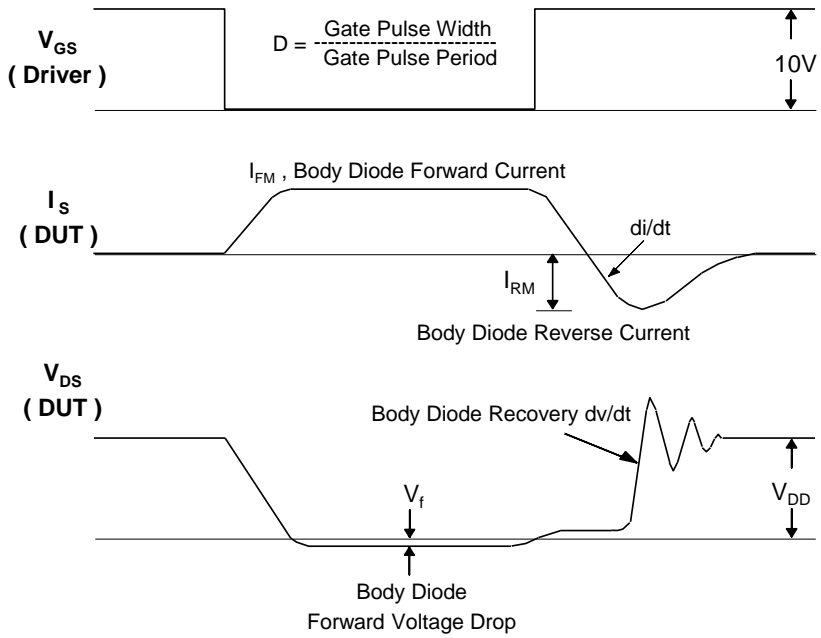
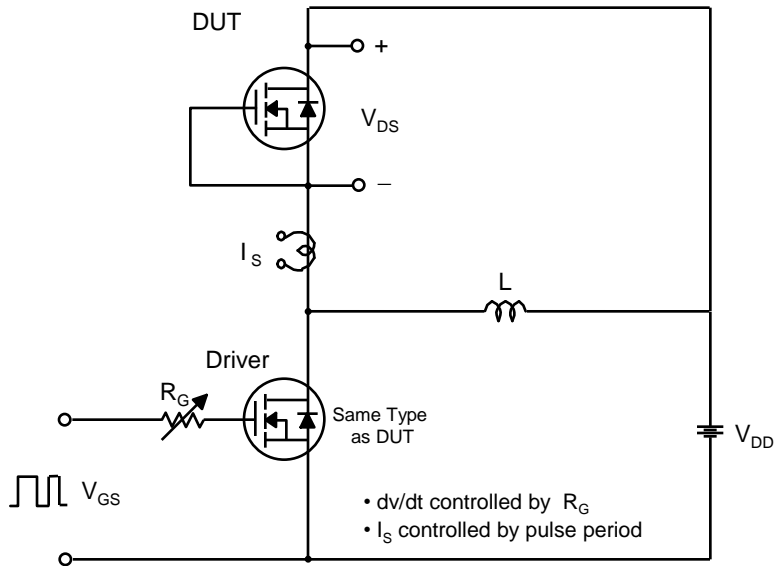
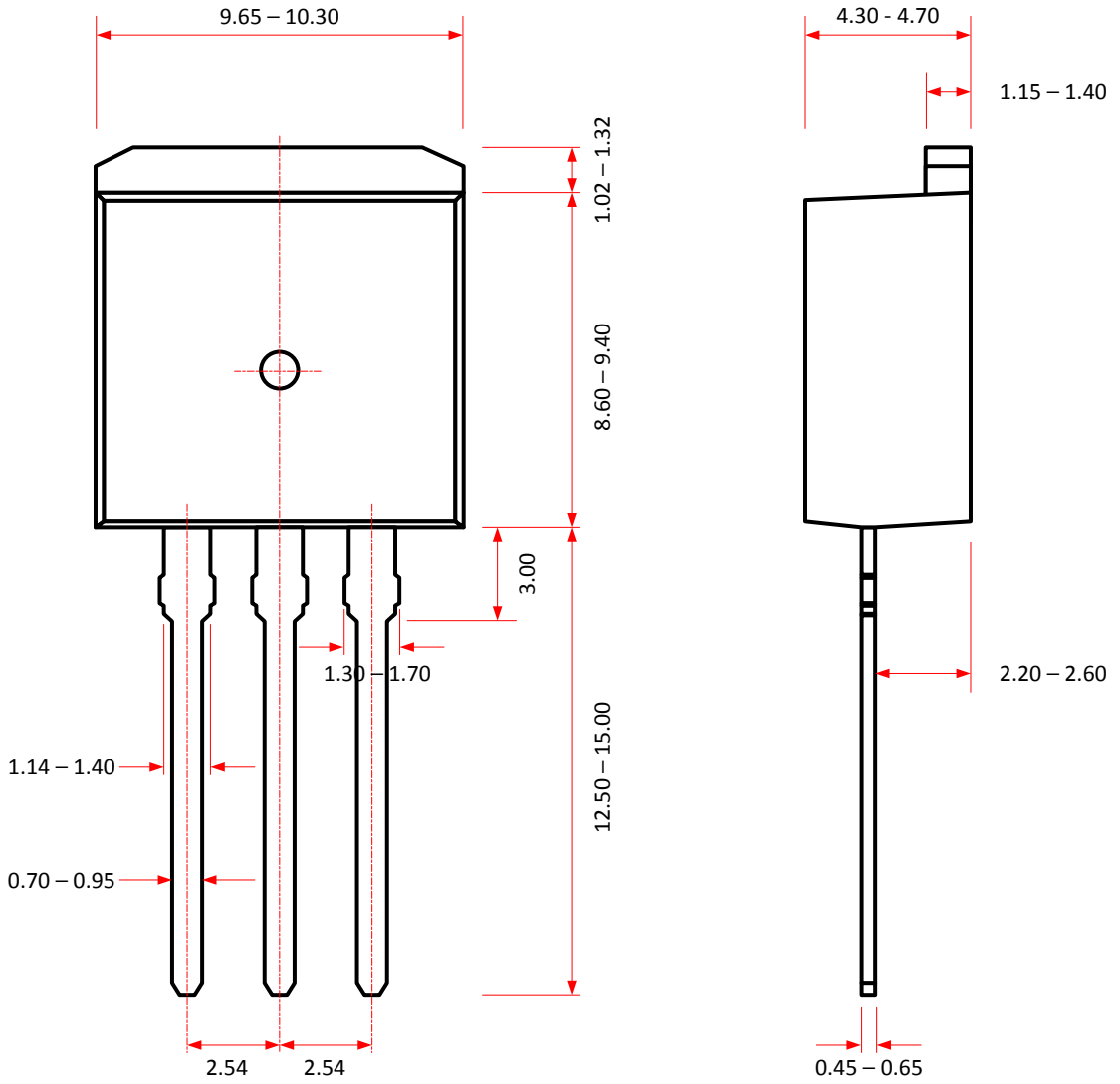

Fig 17. Peak Diode Recovery dv/dt Test Circuit & Waveforms

Package Dimension

TO-262 (I2-PAK)



Package Dimension

TO-263 (D2-PAK)

