



PALM TECHNOLOGY CO., LTD.

The LCD(M) Specialist

CONTACT ADDRESS : 14F-15F, No.383, Yangming Rd., Sanmin District, Kaohsiung
City 807, Taiwan, R.O.C.

Tel: 886-7-3983966

Fax: 886-7-3982966

E-mail: sales@palmtech.com.tw

PART NO. : PFG35BT-TCLW-1

FOR MESSRS. : _____

CONTENTS

NO.	ITEM	PAGE
1.	Cover	1
2.	Record of reversion	2
3.	Features	3
4.	General specification	3
5.	Input/output terminals	4-6
6.	Absolute maximum ratings	7
7.	Electrical characteristics	8~9
8.	Block diagram	10
9.	Timing chart	11
10.	Power sequence	12
11.	Optical characteristics	13~18
12.	Reliability	19
13.	Handling caution	20~22
14.	Mechanical drawing	23



ACCEPTED BY : _____ PROPOSED BY : _____

PALM TECHNOLOGY CO., LTD. Tel:886-7-3983966 Fax:886-7-3982966	PFG35BT-TCLW-1	PAGE:1/23
---	-----------------------	------------------

RECORD OF REVISION

DATE	PAGE	SUMMARY

1. FEATURES

The 3.5"(8.89 cm) LCD module is the Transflective active matrix color TFT LCD module. LTPS (Low Temperature Poly Silicon) TFT technology is used and vertical and horizontal drivers are built on the panel. Highly integrated LCD module includes touch panel, backlight and TFT LCD panel with minimal external circuits and components required.

2. GENERAL SPECIFICATION

Item		Description	Unit
Display Size (Diagonal)		3.5 inch (8.9cm)	-
Display Type		Transflective	-
Active Area (HxV)		53.64 x 71.52	mm
Number of Dots (HxV)		240 x RGB x 320	dot
Dot Pitch (HxV)		0.0745 x 0.2235	mm
Color Arrangement		RGB Stripe	-
Color Numbers		262,144 (6 bits)	-
Outline Dimension (HxVxT)		64 x 85 x 4.05 (Max 4.9)*	mm
Weight		42	g
Power consumption	LCD Panel + T-CON + L/S	50 (Typ)	mW
	Backlight	432 (Typ, I _F = 20mA)	

* Exclude FPC and protrusions.

3. INPUT/OUTPUT TERMINALS

3.1 TFT LCD module

Recommend connector: HRS FH12-50S-0.5SH(CL586-0529-2)

Pin	Symbol	I/O	Description	Remark
1	VDD	-	Supply voltage for H/V driver (+ 12V)	
2	DE	I	Data enable	
3	NC	-	No connection (leave this pin open)	
4	NC	-	No connection (leave this pin open)	
5	GND	-	Ground	
6	VEE	-	Supply voltage for V driver (-6.5V)	
7	GND	-	Ground	
8	NC	-	No connection (leave this pin open)	
9	R0	I	Video data red 0 (LSB)	
10	R1	I	Video data red 1	
11	R2	I	Video data red 2	
12	R3	I	Video data red 3	
13	R4	I	Video data red 4	
14	R5	I	Video data red 5 (MSB)	
15	G0	I	Video data green 0 (LSB)	
16	G1	I	Video data green 1	
17	G2	I	Video data green 2	
18	G3	I	Video data green 3	
19	G4	I	Video data green 4	
20	G5	I	Video data green 5 (MSB)	
21	B0	I	Video data blue 0 (LSB)	
22	B1	I	Video data blue 1	
23	B2	I	Video data blue 2	
24	B3	I	Video data blue 3	
25	B4	I	Video data blue 4	
26	B5	I	Video data blue 5 (MSB)	
27	NC	-	No connection (leave this pin open)	
28	NC	-	No connection (leave this pin open)	
29	NC	-	No connection (leave this pin open)	
30	CLK	I	Video data clock	
31	NC	-	No connection (leave this pin open)	
32	NC	-	No connection (leave this pin open)	
33	VCC5	-	Supply voltage for 5V logic	

34	VCC5	-	Supply voltage for 5V logic	
35	NC	-	No connection (leave this pin open)	
36	NC	-	No connection (leave this pin open)	
37	VCC3	-	Supply voltage for 3.3V logic	
38	VCC3	-	Supply voltage for 3.3V logic	
39	NC	-	No connection (leave this pin open)	
40	NC	-	No connection (leave this pin open)	
41	GND	-	Ground	
42	Anode R	-	LED Power Supply (+)	
43	Cathode R	-	LED Power Supply (-)	
44	Anode L	-	LED Power Supply (+)	
45	Cathode L	-	LED Power Supply (-)	
46	GND	-	Ground	
47	XR	-	Touch Panel Right Side Pin	
48	YL	-	Touch Panel Lower Side Pin	
49	XL	-	Touch Panel Left Side Pin	
50	YU	-	Touch Panel Upper Side Pin	

3.2 Touch panel Pin

Touch Panel Pin	Module Pin	Symbol	Description	Remark
1	47	XR	Touch Panel Right Side	
2	48	YL	Touch Panel Lower Side	
3	49	XL	Touch Panel Left Side	
4	50	YU	Touch Panel Upper Side	

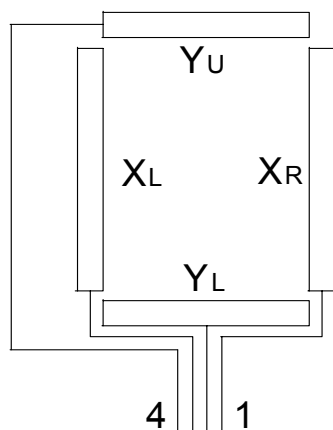

Pin Assignment for Touch Panel

3.3 Back light pin assignment

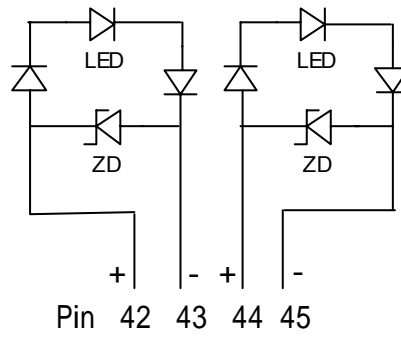

4. ABSOLUTE MAXIMUM RATINGS

GND=0V

Item	Symbol	MIN	MAX	Unit	Remark
Logic Supply Voltage	VCC3	-0.3	4	V	
	VCC5	-0.3	6	V	
Power Supply for H/V Driver	VDD	-1.0	+14	V	
	VEE	-7.5	-5.0	V	Note 1
Data Input Voltage	R[5:0], G[5:0], B[5:0], CLK, DE	-0.3	VCC3+0.3	V	
Touch Panel Operation Voltage	V_{Touch}	-	5.5	V	
Backlight LED forward Voltage	V_F	-	30	V	
Backlight LED reverse Voltage	V_R	-	5	V	
Backlight LED forward current ($T_a=25$)	I_F	-	30	mA	Note2
Operating Temperature	T_{opr}	-10	+55		
Storage Temperature	T_{stg}	-20	+70		

Note1. The operating voltage is between +0.5V and -5.0V at the moment when the power is turned on

Note 2. Relation between maximum LED forward current and ambient temperature is showed as bellow.

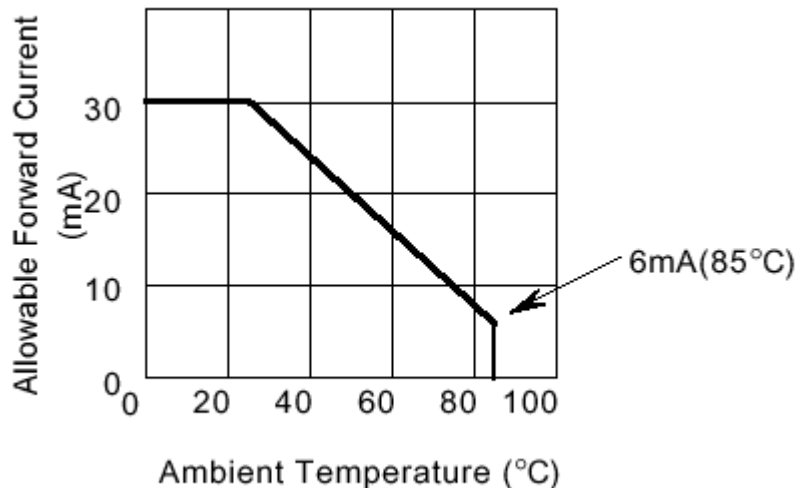

5. ELECTRICAL CHARACTERISTICS

5.1 Driving TFT LCD Panel

T a=25

Item	Symbol	MIN	TYP	MAX	Unit	Remark
Logic Supply Voltage	VCC3	3.0	3.3	3.6	V	
	VCC5	4.5	5.0	5.5	V	
Power Supply for H/V Driver	VDD	11.1	11.7	12.3	V	
	VEE	-7	-6.5	-6	V	
Data Input Voltage	High	VIH	2.4	-	V	R[5:0], G[5:0], B[5:0], CLK DE
	Low	VIL	0	-		
VCC3 Supply Current	I _{VCC3}	-	1.7	3.0	mA	Note 1
VCC5 Supply Current	I _{VCC5}	-	5.5	7.0	mA	Note 2
VDD Supply Current	I _{VDD}	-	1.2	2	mA	
VEE Supply Current	I _{VEE}	-	10	30	uA	

Note 1: The typical supply current specification is measured at the line inversion test pattern (black and white interlacing horizontal lines as the diagram shown below)



Note 2: Gamma correction voltage is set to achieve the optimum at VCC5=5.0V. Use the voltage at level as close to 5.0V as possible.

5.2 DC/DC Spec

Item	Input voltage			Input Current	Input ripple(Max)	
	MIN	TYP	MAX			
VCC3	3.0 V	3.3 V	3.6 V	3.2 mA	200 mV	
VCC5	4.5 V	5 V	5.5 V	7.2 mA	50 mV	Note 1
VDD	11.1 V	11.7 V	12.3 V	2.2 mA	200 mV	
VEE	-7 V	-6.5 V	-6 V	0.04 mA	200 mV	

Note 1: 1.The VCC5 input ripple bandwidth of condition <20MHz.

2. VCC5 is analog voltage supply therefore use as less ripple as possible.

5.3 Driving backlight

Ta=25

Item	Symbol	MIN	TYP	MAX	Unit	Remark
Forward Current	I_F	-	20	30	mA	LED/Part
LED Life Time	-	-	10,000	-	Hr	I_F : 18mA
Forward Current Voltage	V_F	-	3.6	3.9	V	I_F : 20mA ,LED/Part

Note : Backlight driving circuit is recommend as the fix current circuit.

5.4 Driving touch panel (Analog resistance type)

Ta=25

Item	Symbol	MIN	TYP	MAX	Unit	Remark
Resistor between terminals (XR-XL)	Rx	250	-	1100		
Resistor between terminals (YU-YL)	Ry	200	-	700		
Operation Voltage	V_{Touch}	-	5	-	V	DC
Line Linearity (X direction)	-	-1.5	-	+1.5	%	
Line Linearity (Y direction)	-	-1.5	-	+1.5	%	
Chattering	-	-	-	10	ms	
Minimum tension for detecting	-	-	-	80	g	
Insulation Resistance	Ri	20	-	-	M	At DC 25V

6. BLOCK DIAGRAM

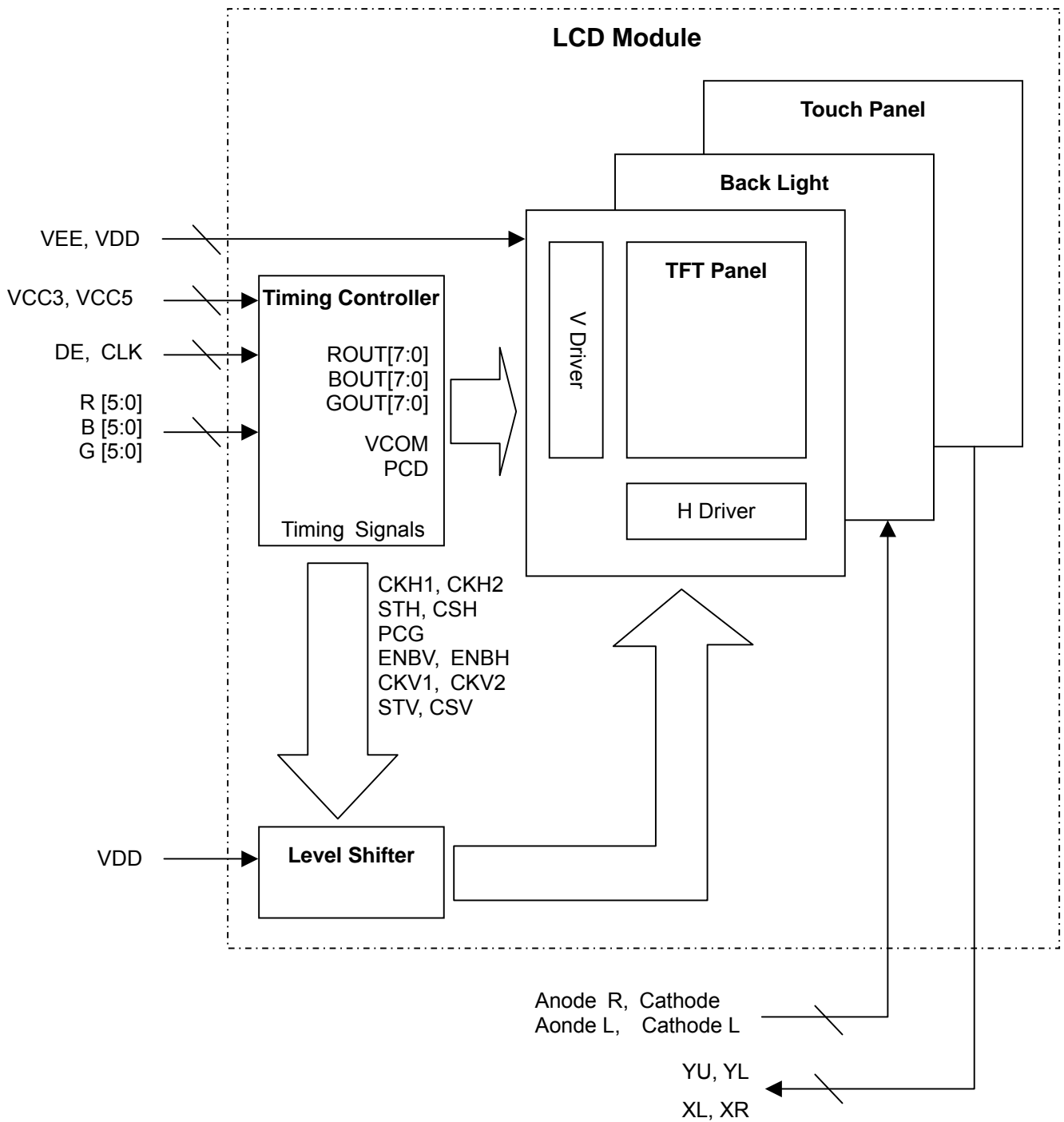

7. TIMING CHART

7.1 Display timing

Item	Symbol	MIN	TYP	MAX	Unit
Vertical Display Active	t_{Vdisp}	-	320	-	$t_{h_display}+t_{h_blank}$
Vertical Blank Time	t_{Vblank}	7	13	22	$t_{h_display}+t_{h_blank}$
Horizontal Display Active	t_{Hdisp}	-	240	-	clk
Horizontal Blank Time	t_{Hblank}	79	80	100	clk
DE Inactive to CLK Rising Edge	t_{dei}	6	-	-	ns
DE Active to CLK Rising Edge	t_{dea}	6	-	-	ns
Clock frequency	f_{clk}	6.0	6.4	7.1	MHz
Data Setup Time	t_{dsu}	5	-	-	ns
Data Hold Time	t_{dhd}	10	-	-	ns

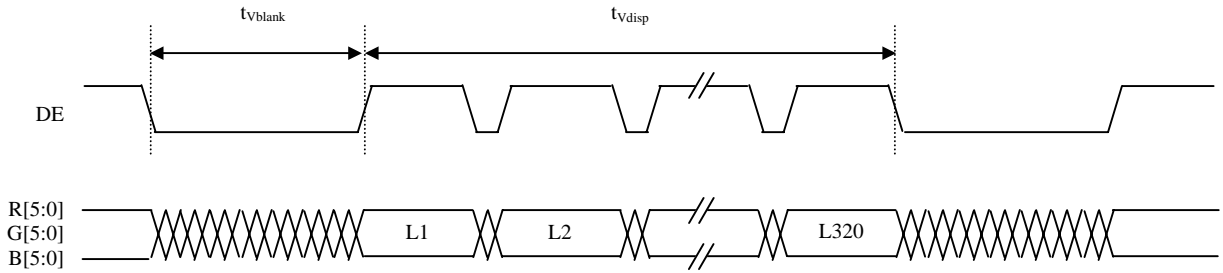

Vertical Timing

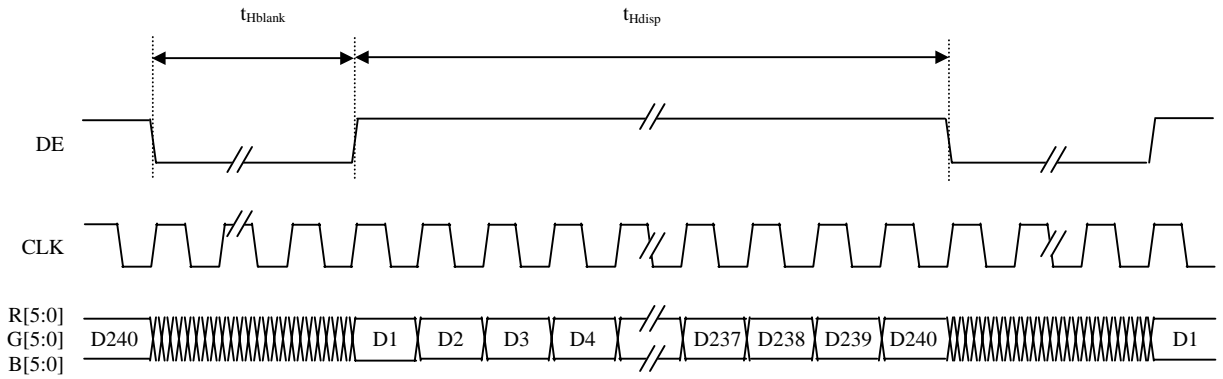

Horizontal Timing

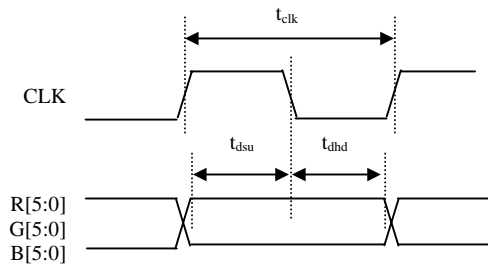

9. OPTICAL CHARACTERISTICS

9.1 Optical Specification

(1) Back light Off / w Touch panel

Ta=25

Item	Symbol	Condition	MIN	TYP	MAX	Unit	Remarks	
Viewing Angles	11	CR ≥ 2	40	50	-	Degree	Note 9-1	
	12		40	50	-			
	21		45	55	-			
	22		45	55	-			
Chromaticity	Red	x	=0°	0.31	0.36	0.41	-	Note 9-3
		y		0.26	0.31	0.36		
	Green	x		0.28	0.33	0.38		
		y		0.29	0.34	0.39		
	Blue	x		0.25	0.3	0.35		
		y		0.24	0.29	0.34		
	White	x		0.28	0.33	0.38		
		y		0.28	0.33	0.38		
Contrast Ratio	CR	=10°	7:1	10:1	-	-	Note 9-2	
Reflectivity	R	=10°	10	15	-	%	Note 9-4	

(2) Back Light On /w Touch panel

Ta=25

Item	Symbol	Condition	MIN	TYP	MAX	Unit	Remarks	
Viewing Angles	11	CR ≥ 2	45	60	-	Degree	Note 9-1	
	12		35	45	-			
	21		35	45	-			
	22		45	60	-			
Response Time	Tr	=0°	-	10	17	ms	Note 9-5	
	Tf	=0°	-	15	23	ms		
Contrast Ratio	CR	=0°	55:1	80:1	-	-	Note 9-6	
Luminance	L	=0° I _F =20mA	80	100	-	cd/m ²	Note 9-7	
NTSC	-	-	32	39	-	%	Note 9-7	
Uniformity	-	-	70	80	-	%	Note 9-8	
Chromaticity	Red	x	=0°	0.49	0.54	0.59	-	Note 9-3
		y		0.29	0.34	0.39		
	Green	x		0.27	0.32	0.37		
		y		0.51	0.56	0.61		
	Blue	x		0.12	0.17	0.22		
		y		0.09	0.14	0.19		
	White	x		0.26	0.31	0.36		
		y		0.28	0.33	0.38		

9.2 Basic measure condition

(1) Driving voltage

VDD= 12.0V, VEE=-6.5V

(2) Ambient temperature: Ta=25

(3) Testing point: measure in the display center point and the test angle =0°

(4) Testing Facility

Environmental illumination: ≤ 10 Lux

a. System A

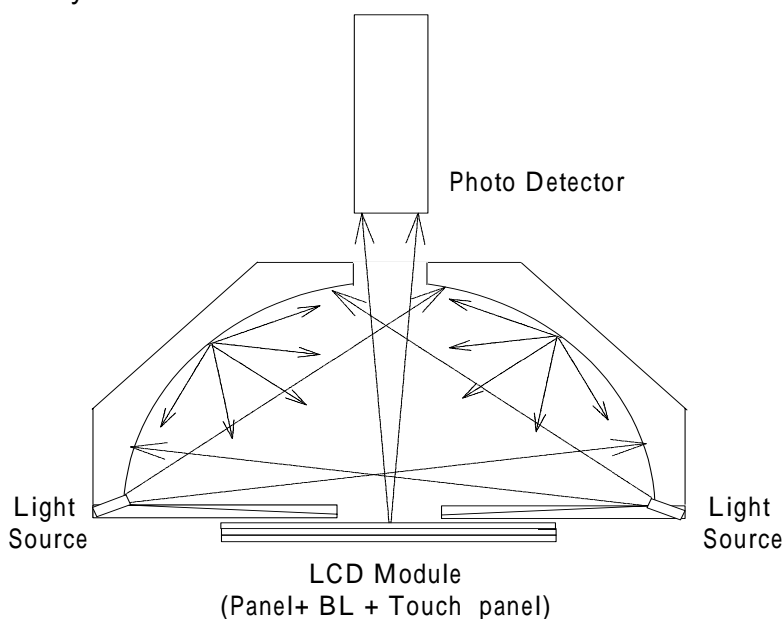

b. System B

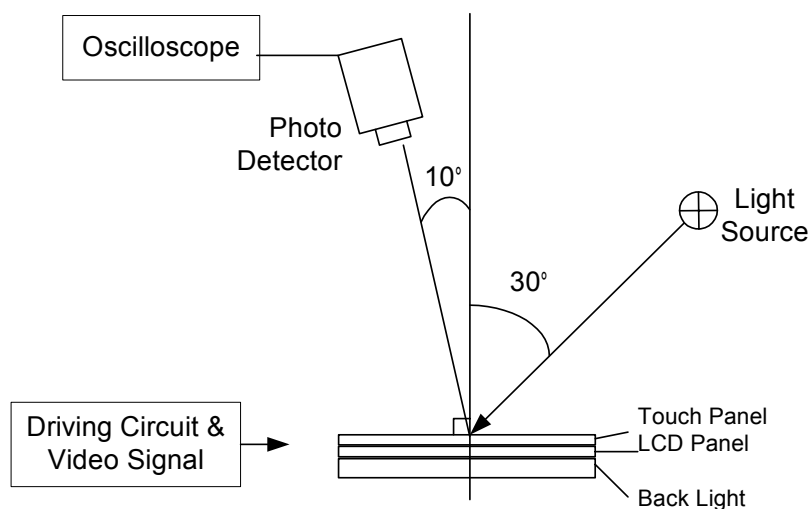

c. System C

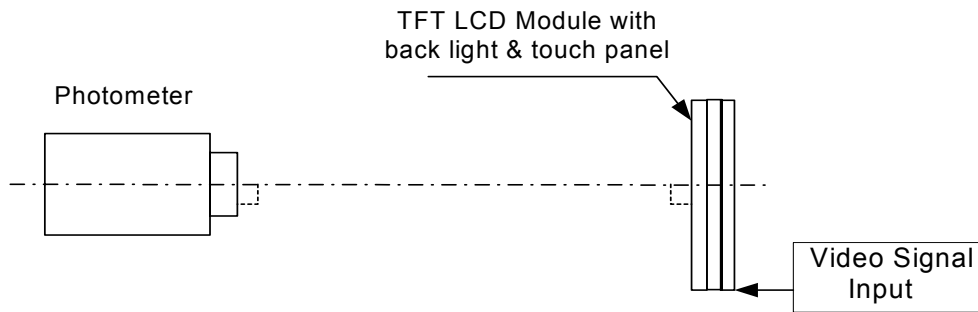

Note 9-1: Viewing angle diagrams (Measure System B)

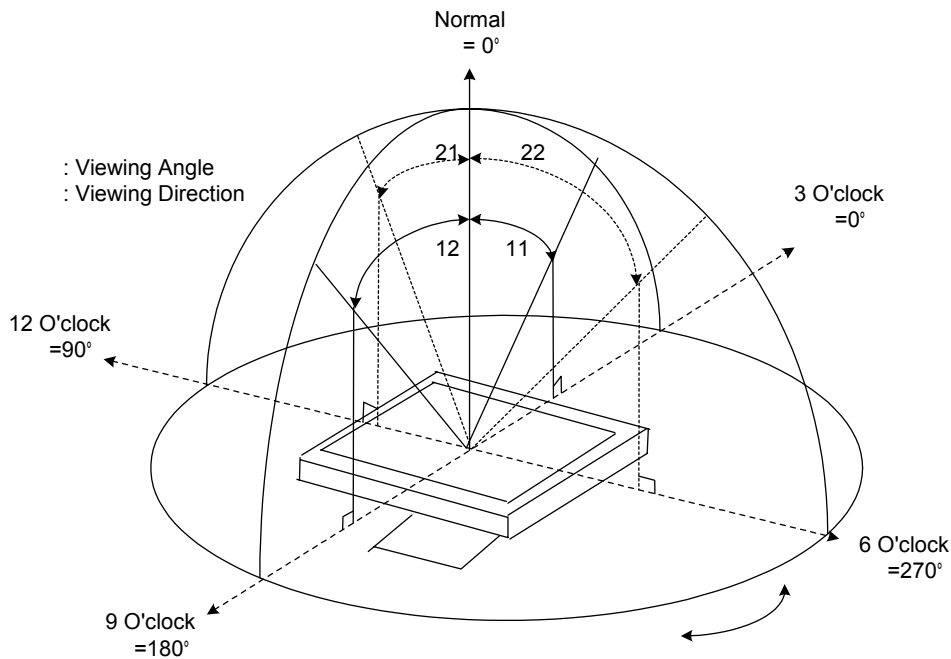

Note 9-2: Contrast ratio in back light off (Measure System B)

Contrast Ratio is measured in optimum common electrode voltage.

$$CR = \frac{\text{Luminance with white image}}{\text{Luminance with black image}}$$

Note 9-3: White chromaticity as back light off: (Measure System A)

Note 9-4: Reflectivity (R) (Measure System B)

In the measuring system B. calculate the reflectance by the following formula.

$$\text{Reflectivity}(R) = \frac{\text{Output from the white display panel}}{\text{Output from the reflectance standard}} \times \text{Reflectance factor of reflectance standard}$$

Note 9-5: Definition of response time: (Measure System C)

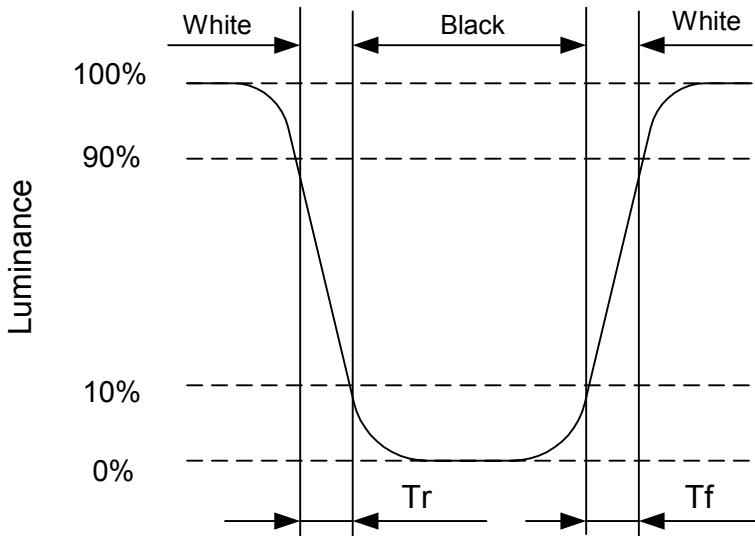

Note 9-6: Contrast Ratio in back light On (Measure System C)

Contrast Ratio is measured in optimum common electrode voltage.

$$CR = \frac{\text{Luminance with white image}}{\text{Luminance with black image}}$$

Note 9-7: Luminance: (Measure System C)

Test Point: Display Center

Note 9-8: Uniformity (Measure System C)

The luminance of 9 points as the black dot in the figure shown below are measured and the uniformity is defined as the formula:

$$\text{Uniformity} = \frac{\text{The minimum luminance among 9 points}}{\text{The maximum luminance among 9 points}}$$

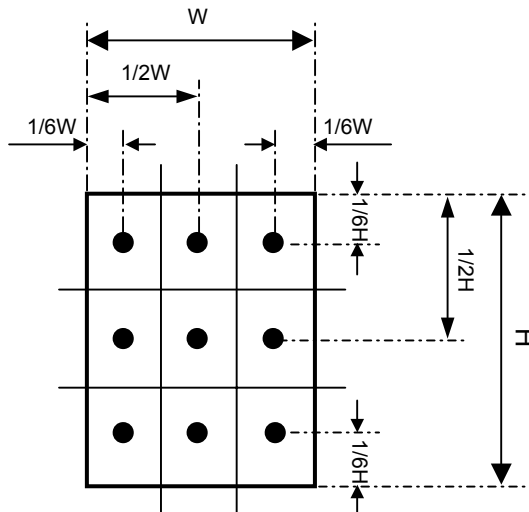

Active Area (W x H)

10. RELIABILITY

No	Test Item	Condition
1	High Temperature Operation	Ta=+55 , 240hrs
2	High Temperature & High Humidity Operation	Ta=+40 , 95% RH, 240hrs
3	Low Temperature Operation	Ta= -10 , 240hrs
4	High Temperature Storage (non-operation)	Ta=+70 , 240hrs
5	Low Temperature Storage (non-operation)	Ta= -20 , 240hrs
6	Thermal Shock (non-operation)	-20 ← → 70 , 50 cycles 30 min 30 min
7	Resistance to Static Electricity Discharge (non-operation)	C=200pF, R=0 ; Discharge: ±150V 3 times / Terminal
8	Surface Discharge (non-operation) (LCD surface)	C=150pF, R=330 ; Discharge: Air: ±15kV; Contact: ±8kV 5 times / Point; 5 Points / Panel
9	Vibration (non-operation)	Frequency: 10~55Hz; Amplitude: 1.5mm Sweep Time: 11min Test Time: 2 hrs for each direction of X, Y, Z
10	Shock (non-operation)	Acceleration: 100G; Period: 6ms Directions: ±X, ±Y, ±Z; Cycles: Three times
11	Pin Activation Test (Touch Panel)	Hit 1,000,000 times with a silicon rubber of R8 HS 60. Hitting Force: 250g Hitting Speed: 3 time/sec
12	Writing Friction Resistance Test (Touch Panel)	Pen: 0.8R Polyacetal stylus Load: 250g Speed: 3 Strokes/sec Stroke: 35mm

11. HANDLING CAUTION

11.1 ESD (Electrical Static Discharge) strategy

ESD will cause serious damage of the panel, ESD strategy is very important in handling. Following items are the recommend ESD strategy

- (1) In handling LCD panel, please wear non-charged material gloves. And the conduction ring connect wrist to the earth and the conducting shoes to the earth is necessary.
- (2) The machine and working table for the panel should have ESD prohibition strategy.
- (3) In handling the panel, ionize flowing decrease the charge in the environment is necessary.
- (4) In the process of assembly the module, shield case should connect to the ground.

11.2 Environment

- (1) Working environment of the panel should in the clean room.
- (2) Because touch panel has protective film on the surface, please remove the protection film slowly with ionized air to prevent the electrostatic discharge.

11.3 Touch panel

- (1) The front touch panel is vulnerable to heavy weight, so any input must be done by special stylus or by a finger. Do not put any heavy stuff on it.
- (2) When any dust or stain is observed on a film surface, clean it using a lens cleaner for glasses or something similar.

11.4 Others

- (1) Turn off the power supply before connecting and disconnecting signal input cable.
- (2) Because the connection area of FPC and panel is not so strong, do not handle panel only by FPC or bend FPC.
- (3) Water drop on the surface or condensation as panel power on will corrode panel electrode.
- (4) As the packing bag open, watch out the environment of the panel storage. High temperature and high humidity environment is prohibited.
- (5) In the case the TFT LCD module is broken, please watch out whether liquid crystal leaks out or not. If your hand touches liquid crystal, wash your hands cleanly with water and soap as soon as possible

11.5 Designing note on touch panel

- (1) Explanation of each boundary of touch panel

1. Boundary of Double-sided adhesive

- a. Electrically detectable within this zone.

When holding the touch panel by housing, it needs to be held at outside of this zone.

- b. Film is supported by double-sided adhesive tape.

2. Viewing area

- a. Cosmetic inspection to be done for this area.

This area is set as inside of boundary of double-sided adhesive with tolerance.

3. Boundary of transparent insulation

- a. Purpose is to "Help" to secure insulation.
- b. Electrical insulation on this area is not guaranteed.
- c. We do recommend not to hold by something like housing or gasket.

4. Active area

- a. This area is where the performance is guaranteed.

This area set as 2.3mm inside from the boundary area of double-sided adhesive tape since its neighboring area is less durable to writing friction.

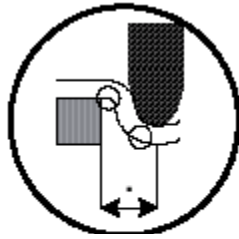

There is some possibility to damage ITO

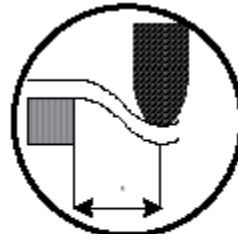

No Damage to ITO

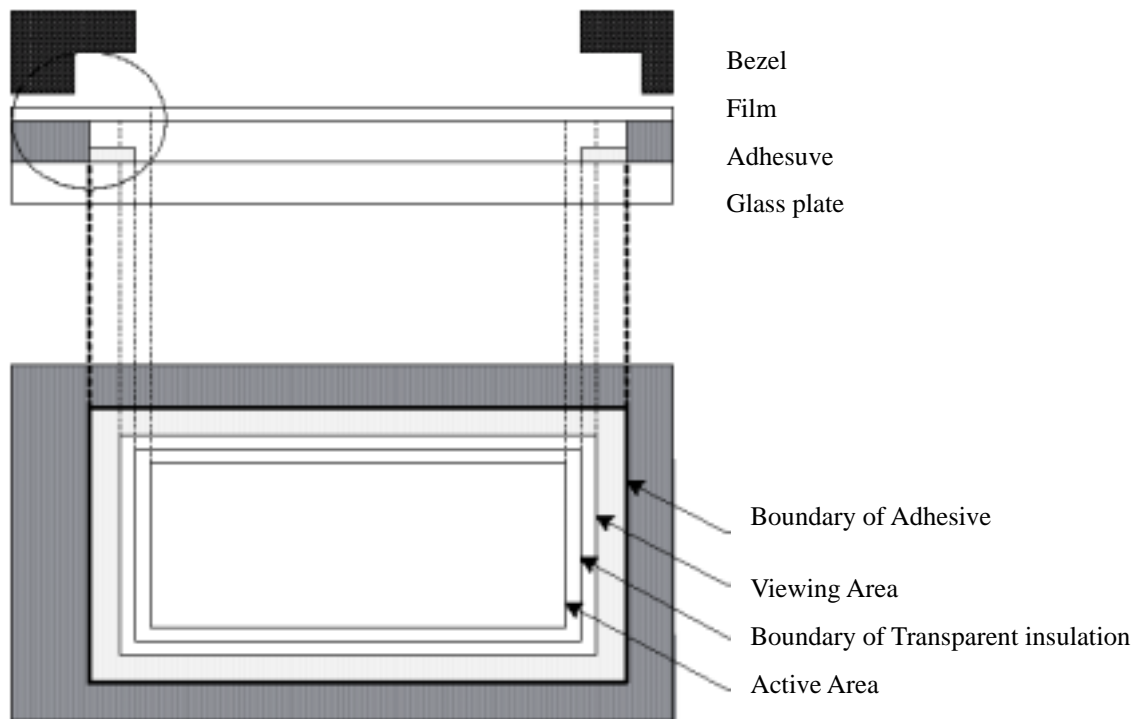

(2) Housing and touch panel

- a. Please have clearance between side of touch panel, and any conductive material such as metal frame. (Drawing.1) Transparent electrode exists on glass of touch panel from end to end.
- b. It is recommend to fix a touch panel on the LCD chassis rather than housing
Clinging conductive material and side of touch panel might cause the malfunction.

