



FEATURES

- ❑ Originative New Design
- ❑ 100% EAS Test
- ❑ Rugged Gate Oxide Technology
- ❑ Extremely Low Intrinsic Capacitances
- ❑ Remarkable Switching Characteristics
- ❑ Unequalled Gate Charge : 55 nC (Typ.)
- ❑ Extended Safe Operating Area
- ❑ Lower $R_{DS(ON)}$: 1.12 Ω (Typ.) @ $V_{GS}=10V$

APPLICATION

- ❑ High current, High speed switching
- ❑ Suitable for power supplies, adaptors and PFC
- ❑ SMPS (Switched Mode Power Supplies)

PFJ9N90 / PFW9N90 900V N-Channel MOSFET

$$BV_{DSS} = 900 \text{ V}$$

$$R_{DS(on)} = 1.4 \Omega$$

$$I_D = 9 \text{ A}$$

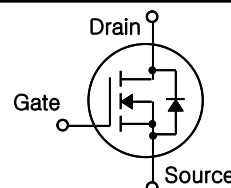

TO-247

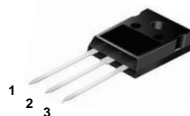

1.Gate 2. Drain 3. Source

TO-3P

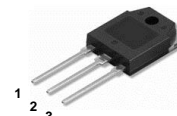

1.Gate 2. Drain 3. Source

Absolute Maximum Ratings $T_C=25^\circ\text{C}$ unless otherwise specified

| Symbol | Parameter | Value | Units |
|----------------|---|-------------|---------------------|
| V_{DSS} | Drain-Source Voltage | 900 | V |
| I_D | Drain Current – Continuous ($T_C = 25^\circ\text{C}$) | 9.0 | A |
| | Drain Current – Continuous ($T_C = 100^\circ\text{C}$) | 5.7 | A |
| I_{DM} | Drain Current – Pulsed (Note 1) | 36 | A |
| V_{GS} | Gate-Source Voltage | ± 30 | V |
| E_{AS} | Single Pulsed Avalanche Energy (Note 2) | 900 | mJ |
| I_{AR} | Avalanche Current (Note 1) | 9.0 | A |
| E_{AR} | Repetitive Avalanche Energy (Note 1) | 28 | mJ |
| dv/dt | Peak Diode Recovery dv/dt (Note 3) | 4.0 | V/ns |
| P_D | Power Dissipation ($T_C = 25^\circ\text{C}$) | 280 | W |
| | – Derate above 25°C | 2.22 | W/ $^\circ\text{C}$ |
| T_J, T_{STG} | Operating and Storage Temperature Range | -55 to +150 | $^\circ\text{C}$ |
| T_L | Maximum lead temperature for soldering purposes, 1/8" from case for 5 seconds | 300 | $^\circ\text{C}$ |

Thermal Resistance Characteristics

| Symbol | Parameter | Typ. | Max. | Units |
|-----------------|---------------------|------|------|---------------------------|
| $R_{\theta JC}$ | Junction-to-Case | -- | 0.45 | $^\circ\text{C}/\text{W}$ |
| $R_{\theta CS}$ | Case-to-Sink | 0.24 | -- | |
| $R_{\theta JA}$ | Junction-to-Ambient | -- | 40 | |

Electrical Characteristics $T_C=25\text{ }^\circ\text{C}$ unless otherwise specified

| Symbol | Parameter | Test Conditions | Min | Typ | Max | Units |
|---------------------------|-----------------------------------|--|-----|------|-----|----------|
| On Characteristics | | | | | | |
| V_{GS} | Gate Threshold Voltage | $V_{DS} = V_{GS}, I_D = 250\ \mu\text{A}$ | 2.5 | -- | 4.5 | V |
| $R_{DS(ON)}$ | Static Drain-Source On-Resistance | $V_{GS} = 10\ \text{V}, I_D = 4.5\ \text{A}$ | -- | 1.12 | 1.4 | Ω |

Off Characteristics

| | | | | | | |
|--------------------------------|---|---|-----|------|------|---------------------------|
| BV_{DSS} | Drain-Source Breakdown Voltage | $V_{GS} = 0\ \text{V}, I_D = 250\ \mu\text{A}$ | 900 | -- | -- | V |
| $\Delta BV_{DSS} / \Delta T_J$ | Breakdown Voltage Temperature Coefficient | $I_D = 250\ \mu\text{A}$, Referenced to $25\text{ }^\circ\text{C}$ | -- | 0.99 | -- | $\text{V}/^\circ\text{C}$ |
| I_{DSS} | Zero Gate Voltage Drain Current | $V_{DS} = 900\ \text{V}, V_{GS} = 0\ \text{V}$ | -- | -- | 1 | μA |
| | | $V_{DS} = 720\ \text{V}, T_C = 125\text{ }^\circ\text{C}$ | -- | -- | 10 | μA |
| I_{GSSF} | Gate-Body Leakage Current, Forward | $V_{GS} = 30\ \text{V}, V_{DS} = 0\ \text{V}$ | -- | -- | 100 | nA |
| I_{GSSR} | Gate-Body Leakage Current, Reverse | $V_{GS} = -30\ \text{V}, V_{DS} = 0\ \text{V}$ | -- | -- | -100 | nA |

Dynamic Characteristics

| | | | | | | |
|-----------|------------------------------|---|----|------|------|----|
| C_{iss} | Input Capacitance | $V_{DS} = 25\ \text{V}, V_{GS} = 0\ \text{V},$ $f = 1.0\ \text{MHz}$ | -- | 2550 | 3310 | pF |
| C_{oss} | Output Capacitance | | -- | 210 | 270 | pF |
| C_{rss} | Reverse Transfer Capacitance | | -- | 18 | 23 | pF |

Switching Characteristics

| | | | | | | |
|--------------|---------------------|---|----|-----|-----|----|
| $t_{d(on)}$ | Turn-On Time | $V_{DS} = 450\ \text{V}, I_D = 9.0\ \text{A},$ $R_G = 25\ \Omega$ (Note 4,5) | -- | 60 | 120 | ns |
| t_r | Turn-On Rise Time | | -- | 145 | 290 | ns |
| $t_{d(off)}$ | Turn-Off Delay Time | | -- | 120 | 240 | ns |
| t_f | Turn-Off Fall Time | | -- | 90 | 180 | ns |
| Q_g | Total Gate Charge | $V_{DS} = 720\ \text{V}, I_D = 9.0\ \text{A},$ $V_{GS} = 10\ \text{V}$ (Note 4,5) | -- | 55 | 70 | nC |
| Q_{gs} | Gate-Source Charge | | -- | 16 | -- | nC |
| Q_{gd} | Gate-Drain Charge | | -- | 21 | -- | nC |

Source-Drain Diode Maximum Ratings and Characteristics

| | | | | | | |
|----------|---|---|----|-----|-----|---------------|
| I_S | Continuous Source-Drain Diode Forward Current | -- | -- | 9.0 | A | |
| I_{SM} | Pulsed Source-Drain Diode Forward Current | -- | -- | 36 | | |
| V_{SD} | Source-Drain Diode Forward Voltage | $I_S = 9\ \text{A}, V_{GS} = 0\ \text{V}$ | -- | -- | 1.4 | V |
| t_{rr} | Reverse Recovery Time | $I_S = 9\ \text{A}, V_{GS} = 0\ \text{V}$ $di_F/dt = 100\ \text{A}/\mu\text{s}$ (Note 4) | -- | 660 | -- | ns |
| Q_{rr} | Reverse Recovery Charge | | -- | 7.8 | -- | μC |

Notes ;

1. Repetitive Rating : Pulse width limited by maximum junction temperature
2. $I_{AS}=9\text{A}, V_{DD}=50\text{V}, R_G=25\Omega$, Starting $T_J=25\text{ }^\circ\text{C}$
3. $I_{SD}\leq 9\text{A}, di/dt\leq 300\text{A}/\mu\text{s}, V_{DD}\leq BV_{DSS}$, Starting $T_J=25\text{ }^\circ\text{C}$
4. Pulse Test : Pulse Width $\leq 300\mu\text{s}$, Duty Cycle $\leq 2\%$
5. Essentially Independent of Operating Temperature

Typical Characteristics

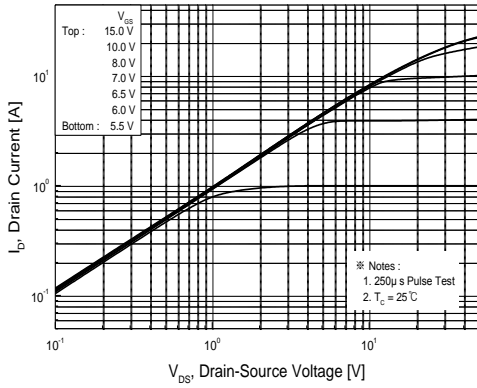

Figure 1. On Region Characteristics

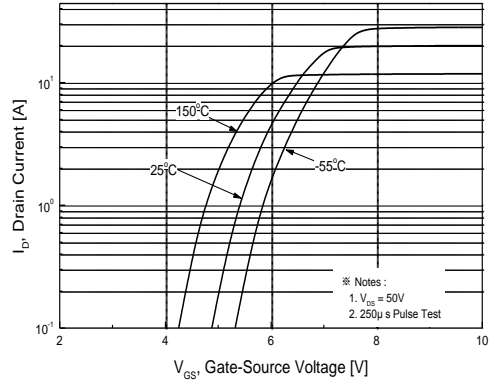

Figure 2. Transfer Characteristics

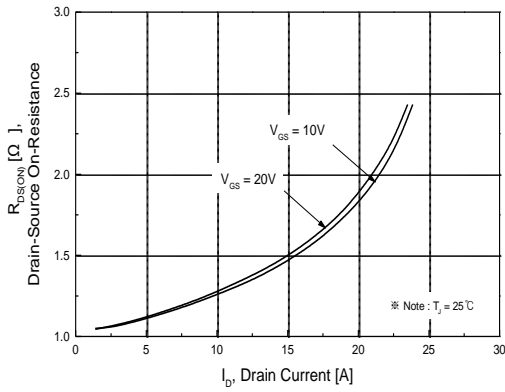

Figure 3. On Resistance Variation vs Drain Current and Gate Voltage

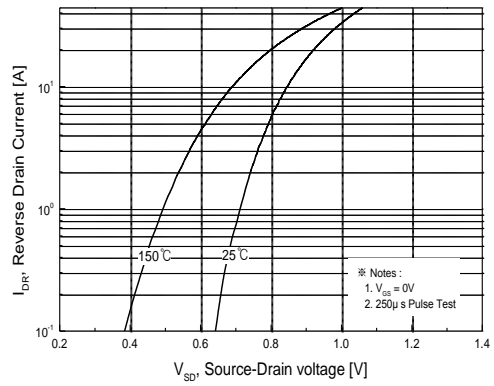

Figure 4. Body Diode Forward Voltage Variation with Source Current and Temperature

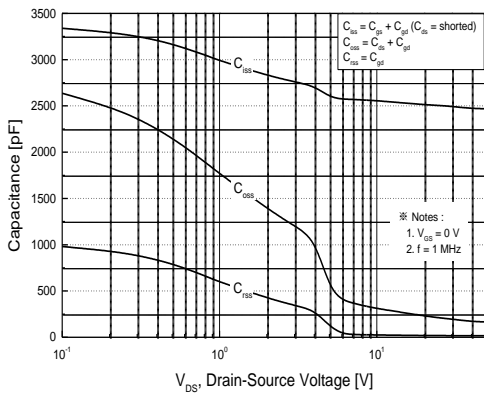

Figure 5. Capacitance Characteristics

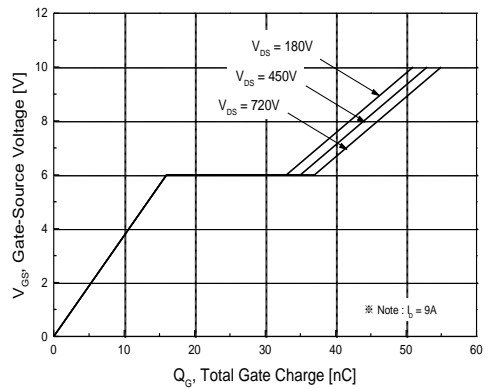

Figure 6. Gate Charge Characteristics

Typical Characteristics (continued)

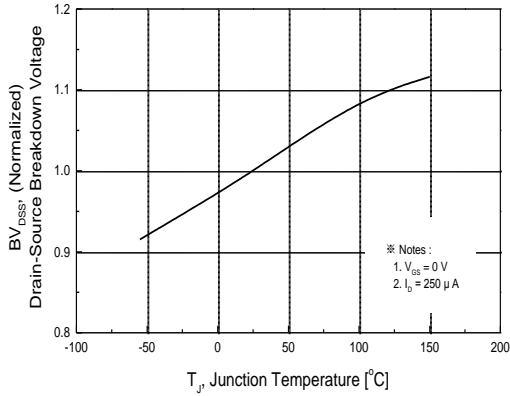

Figure 7. Breakdown Voltage Variation vs Temperature

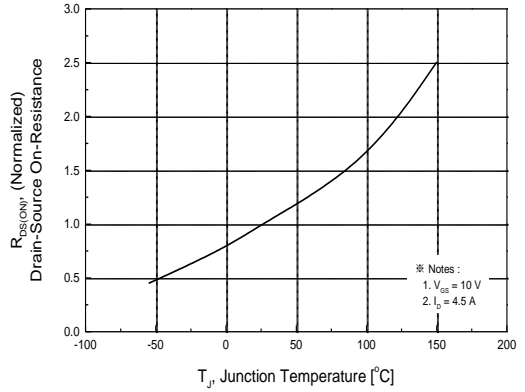

Figure 8. On-Resistance Variation vs Temperature

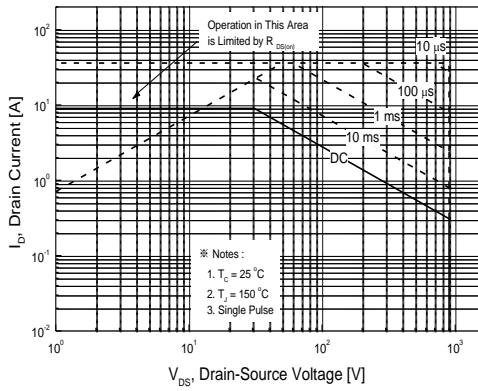

Figure 9. Maximum Safe Operating Area

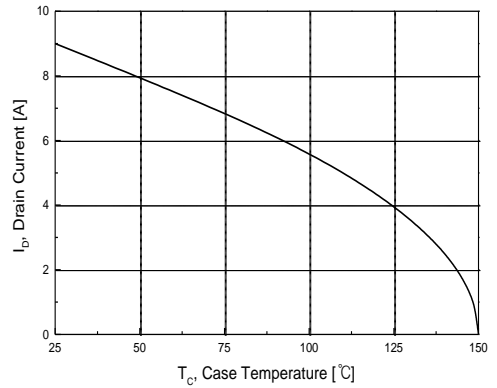

Figure 10. Maximum Drain Current vs Case Temperature

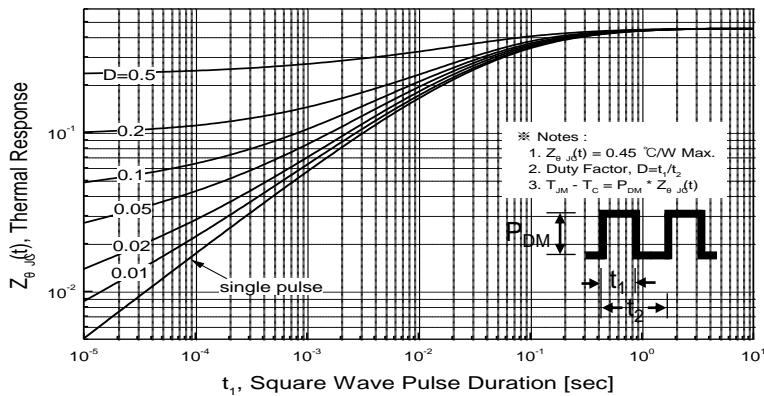

Figure 11. Transient Thermal Response Curve

Characteristics Test Circuit & Waveform

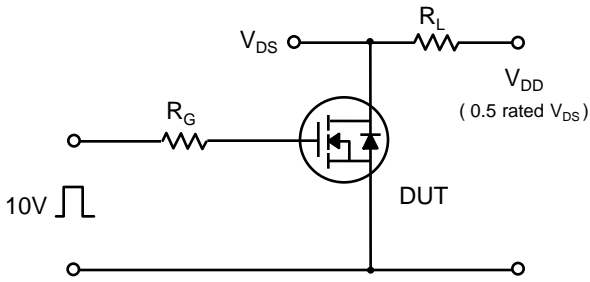

Fig 14. Resistive Switching Test Circuit & Waveforms

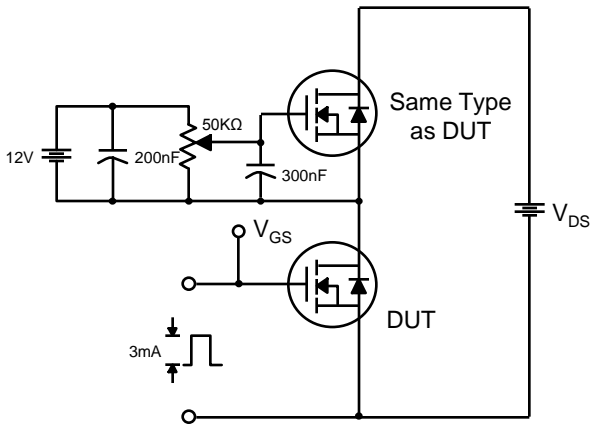

Fig 15. Gate Charge Test Circuit & Waveform

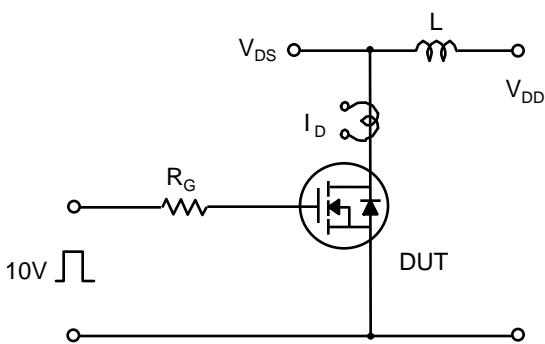
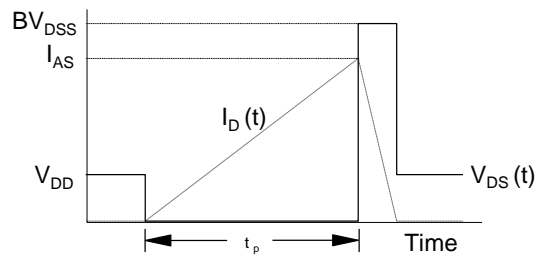

Fig 16. Unclamped Inductive Switching Test Circuit & Waveforms

$$E_{AS} = \frac{1}{2} L_L I_{AS}^2 \frac{BV_{DSS}}{BV_{DSS} - V_{DD}}$$



Characteristics Test Circuit & Waveform (continued)

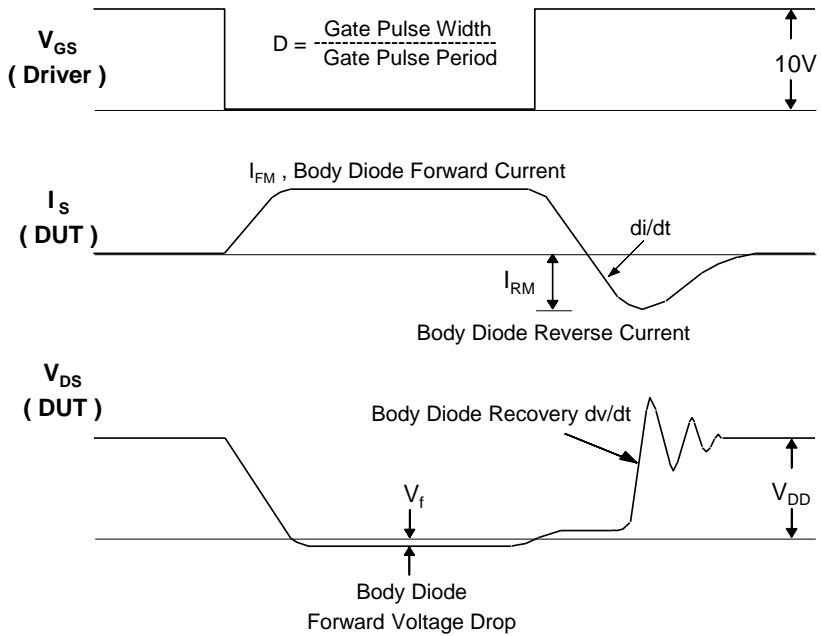
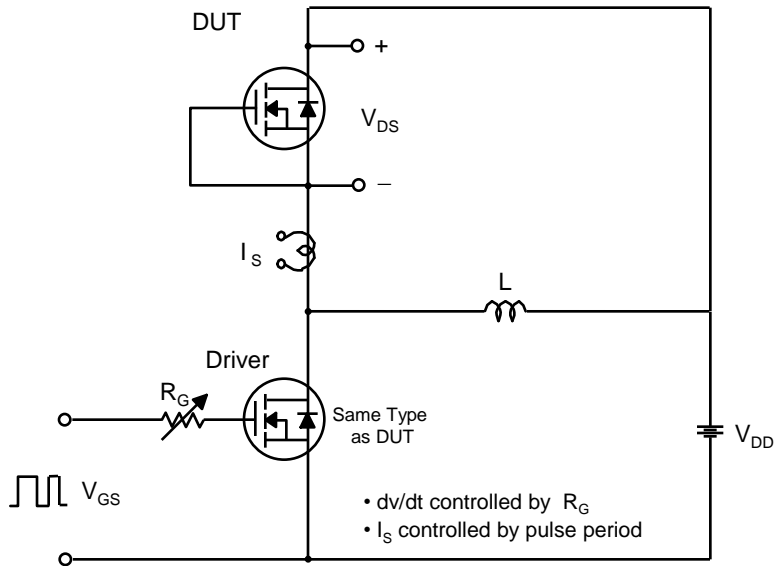
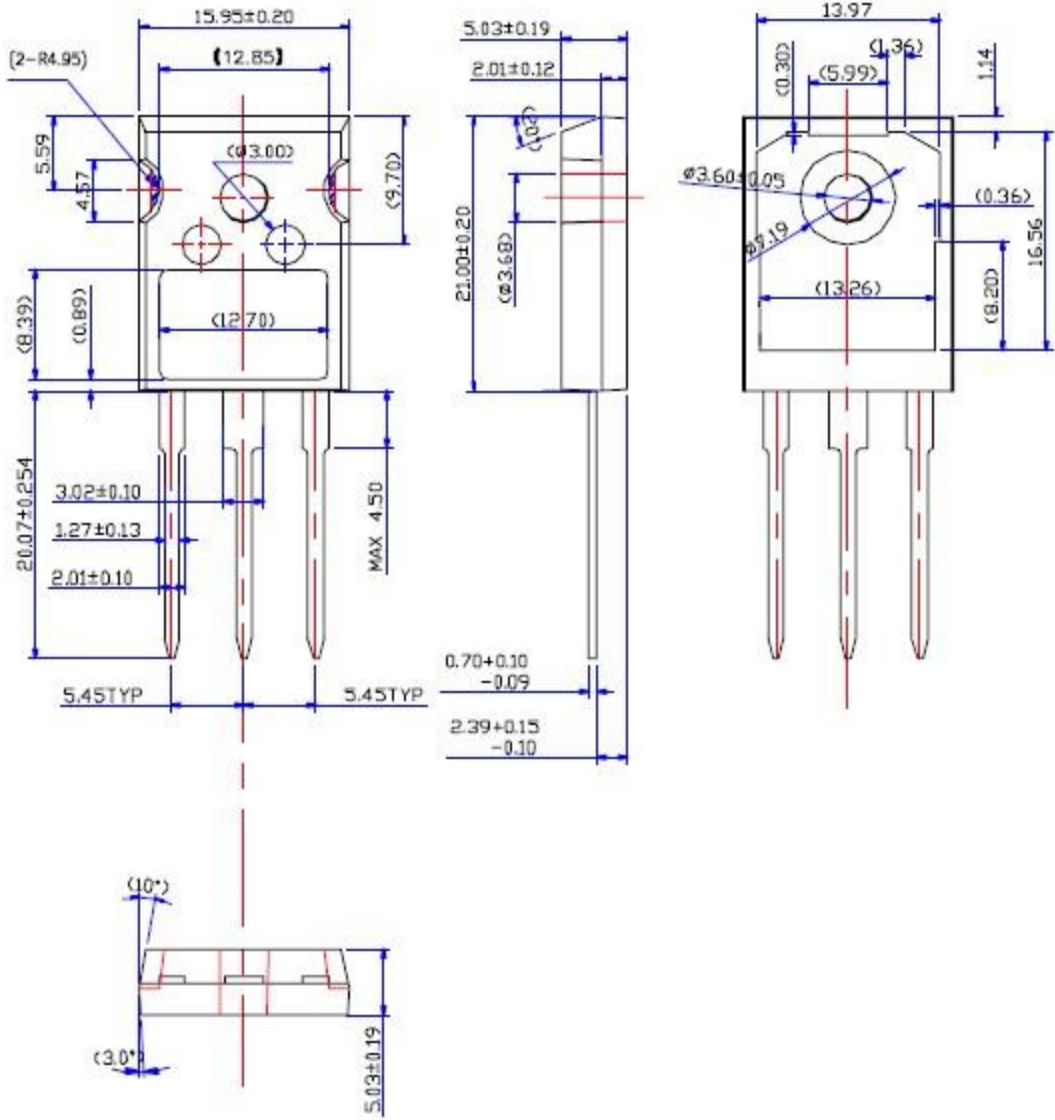

Fig 17. Peak Diode Recovery dv/dt Test Circuit & Waveforms

Package Dimension

TO-247



Package Dimension

TO-3P

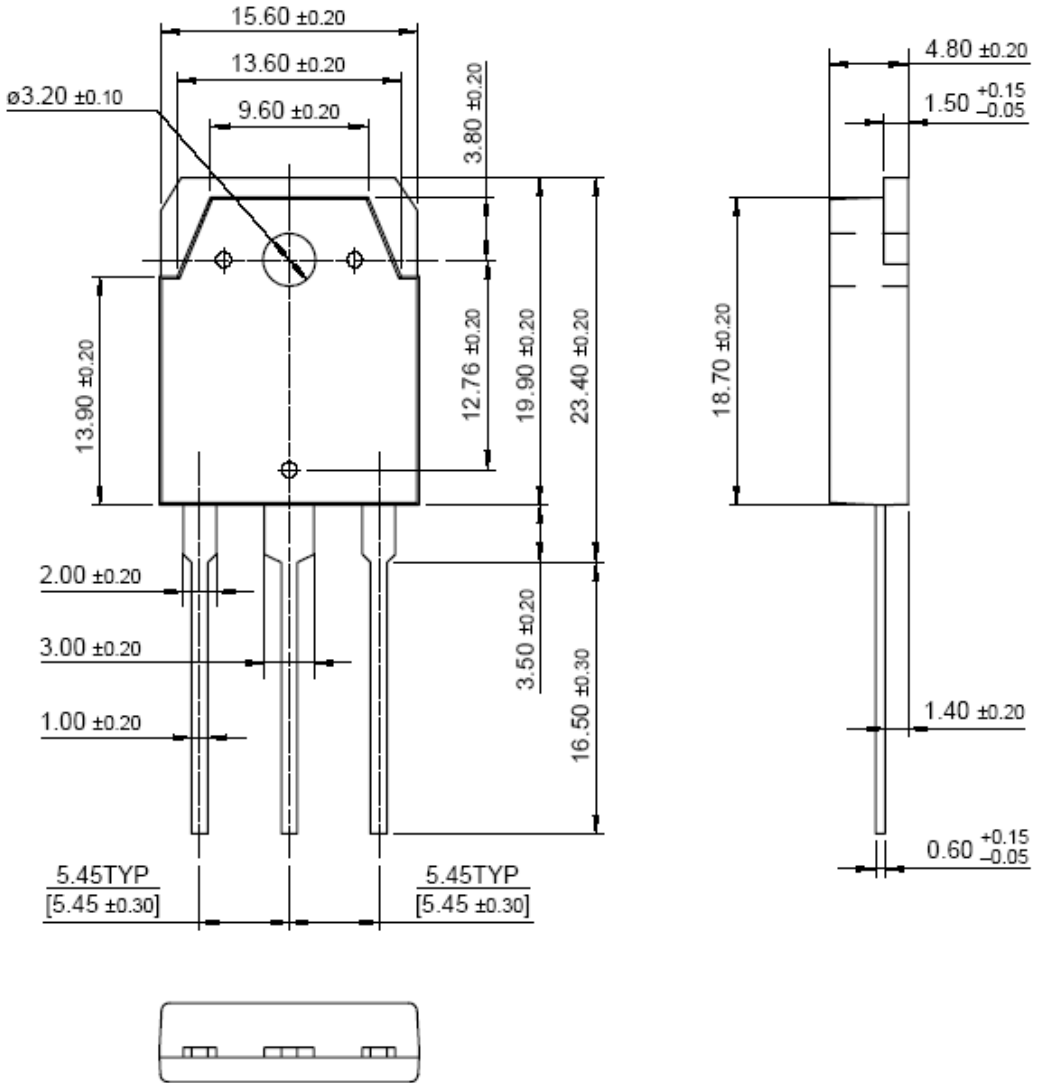

Reliability Qualification

A. High Temperature Reverse Bias (HTRB)

The purpose of this test is to determine the sensitivity of the product to mobile ion contamination and related failure mechanisms.

Conditions: MIL-STD-750C 1038, JIS C 7021 B-3

$T_A=150\text{ }^\circ\text{C}$ $V_{DS}=80\%$ max rated V_{DS}

| Sample Size | #of Fail | Cum. Fail% | 168hrs | 300hrs |
|-------------|----------|------------|--------|--------|
| 45 | 0 | 0.0% | 0 | 0 |

B. High Temperature Gate Bias (HTGB)

The purpose of this test is to determine the sensitivity of the product to mobile ion contamination between gate and source and related failure mechanisms.

Conditions: MIL-STD-750C 1038, JIS C 7021 B-3

$T_A=150\text{ }^\circ\text{C}$ $V_{DS}=V_{GSS}$ max

| Sample Size | #of Fail | Cum. Fail% | 168hrs | 300hrs |
|-------------|----------|------------|--------|--------|
| 45 | 0 | 0.0% | 0 | 0 |

C. Temperature Humidity Bias (THB)

The purpose of this test is to evaluate the moisture resistance of non-hermetic components.

The addition of voltage bias accelerates the corrosive effect after moisture penetration has taken place. with time, this is a catastrophically destructive test.

Conditions: JESD22-A101, JIS C 7021 B-11

$T_A=85\text{ }^\circ\text{C}$ $RH=85\%$ $V_{DS}=80\%$ max rated V_{DS}

| Sample Size | #of Fail | Cum. Fail% | 168hrs | 300hrs |
|-------------|----------|------------|--------|--------|
| 45 | 0 | 0.0% | 0 | 0 |

Reliability Qualification (Continued)

D. High Temperature Storage (HTS)

The purpose of this test is to expose time/temperature failure mechanisms and to evaluate long-term strong stability.

Conditions: MIL-STD-750C 1031.4, JIS C 7021 B-10

$T_A = T_{stg}(\max) 150\text{ }^\circ\text{C}$

| Sample Size | #of Fail | Cum. Fail% | 168hrs | 300hrs |
|-------------|----------|------------|--------|--------|
| 45 | 0 | 0.0% | 0 | 0 |

E. Pressure Cooker Test (PCT)

Autoclave (ACLV)

The purpose of this test is to evaluate the moisture resistance of non-hermetic components under pressure/temperature conditions.

Conditions: MIL-STD-750C 1071.2, JIS C 7021 A-6

$T_A = 121\text{ }^\circ\text{C} \pm 2\text{ }^\circ\text{C}$ RH=100% P=1 atmosphere (15psig)

| Sample Size | #of Fail | Cum. Fail% | 48hrs |
|-------------|----------|------------|-------|
| 22 | 0 | 0.0% | 0 |

F. Temperature Cycle Air-to Air (T/C)

The purpose of this test is to evaluate the ability of the device to withstand both exposure to extreme temperature and the transition between temperature extreme, and to exposure excessive thermal mismatch between materials.

Conditions: JESD22-A104, JIS C 7021 A-4

Air to air, $-65\text{ }^\circ\text{C} \sim 150\text{ }^\circ\text{C}$, 10 minutes dwell time at each temperature

| Sample Size | #of Fail | Cum. Fail% | 100cycles | 200cycles |
|-------------|----------|------------|-----------|-----------|
| 22 | 0 | 0.0% | 0 | 0 |