

Package Outline

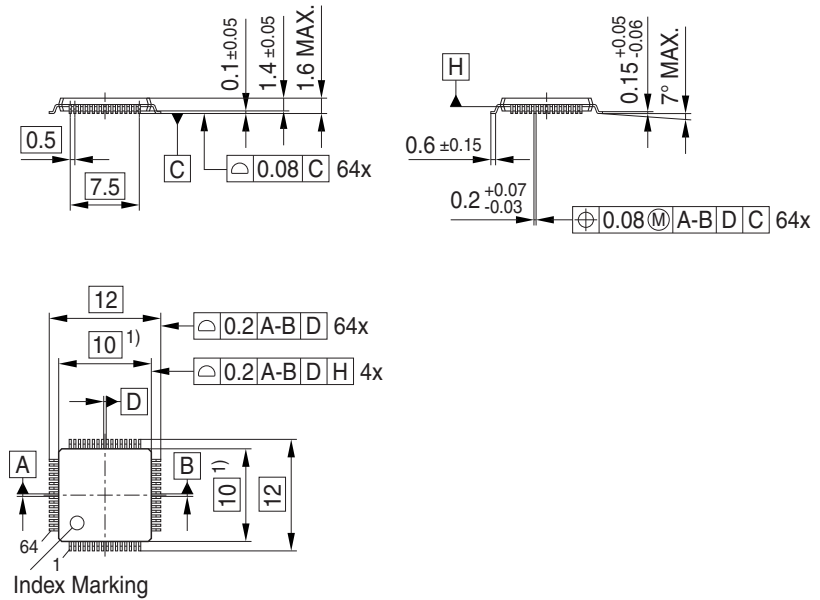

1) Does not include plastic or metal protrusion of 0.25 max. per side

Foot Print

Soldering Type: Reflow Soldering

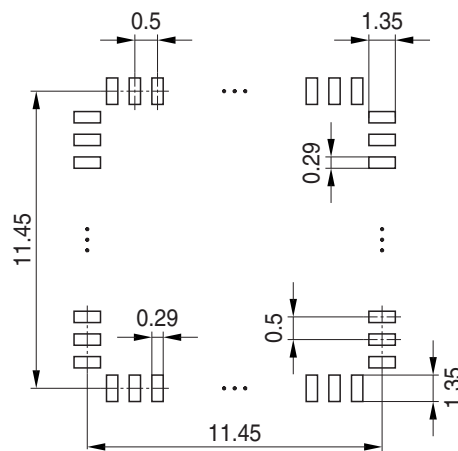

Marking Layout

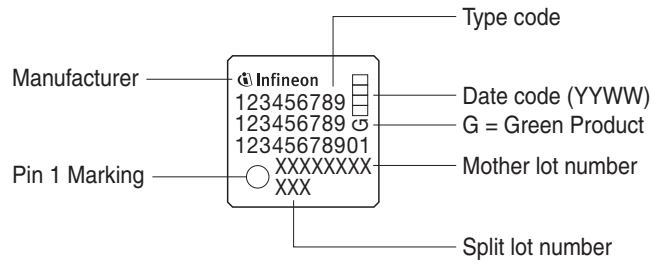

Tape and Reel

Reel \varnothing 330 mm: 1.900 Pieces/Reel

Reels/Box: 1

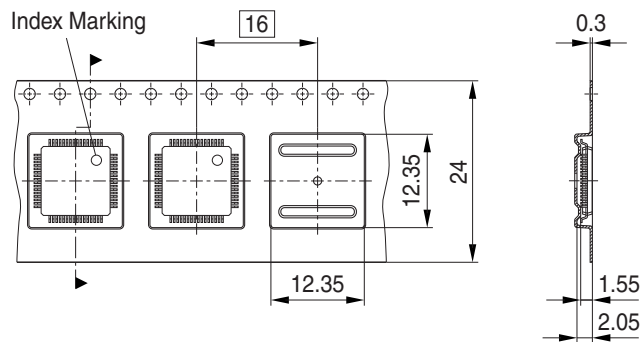

Bakable Tray

Pieces/Tray: 160

Trays/Box: 1; 6

