

Protection in Portable Electronics Applications.

FEATURES

- 100 Watts peak pulse power ($t_p=8/20 \mu s$)
- Transient protection for data lines to IEC 61000-4-2(ESD) 15kV(Air), 8kV(Contact). IEC 61000-4-4(EFT) 40A ($t_p=5/50ns$) IEC 61000-4-5(Lightning) 8A ($t_p=8/20 \mu s$)
- Protects five I/O lines.
- Low clamping voltage.
- Low operating and leakage current.
- Small package for use in portable electronics.

APPLICATIONS

- Cell phone handsets and accessories.
- Cordless phones.
- Personal digital assistants (PDA s)
- Notebooks, desktops, & servers.
- Portable instrumentation.
- Set-Top Box, DVD Player.
- Digital Camera.

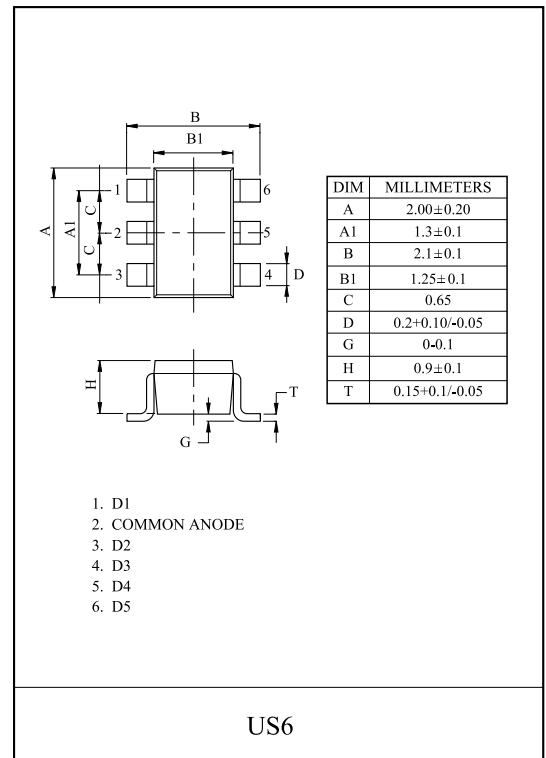

MAXIMUM RATING (Ta=25 °C)

CHARACTERISTIC	SYMBOL	RATING	UNIT
Peak Pulse Power ($t_p=8/20 \mu s$)	P_{PK}	100	W
Peak Pulse Current ($t_p=8/20 \mu s$)	I_{PP}	8	A
Operating Temperature	T_j	-55 150	
Storage Temperature	T_{stg}	-55 150	

Marking

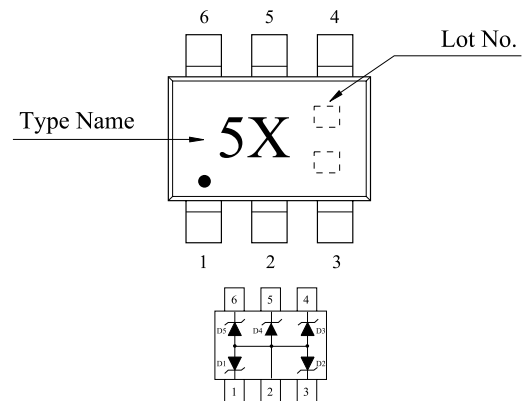

ELECTRICAL CHARACTERISTICS (Ta=25 °C)

CHARACTERISTIC	SYMBOL	TEST CONDITION	MIN.	TYP.	MAX.	UNIT
Reverse Stand-Off Voltage	V_{RWM}	-	-	-	5	V
Reverse Breakdown Voltage	V_{BR}	$I_t=1mA$	6	-	-	V
Reverse Leakage Current	I_R	$V_{RWM}=5V$	-	-	5	μA
Clamping Voltage	V_C	$I_{PP}=1A, t_p=8/20 \mu s$	-	-	8.5	V
		$I_{PP}=8A, t_p=8/20 \mu s$	-	-	12.5	
Junction Capacitance	C_j	$V_R=0V, f=1MHz$ Between I/O Pins and GND	-	-	130	pF

PG05GXUS6

NON-REPETITIVE PEAK PULSE POWER VS. PULSE TIME

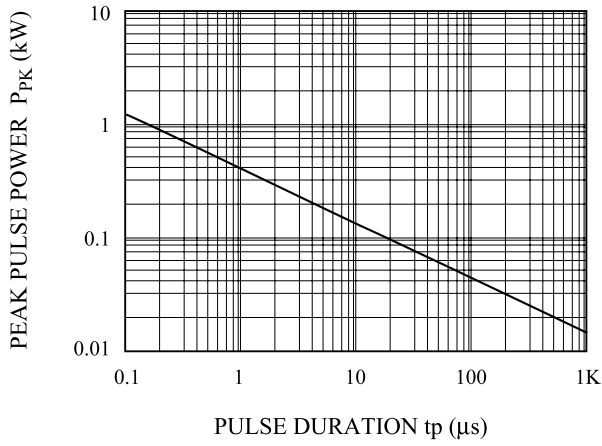

POWER DERATION CURVE

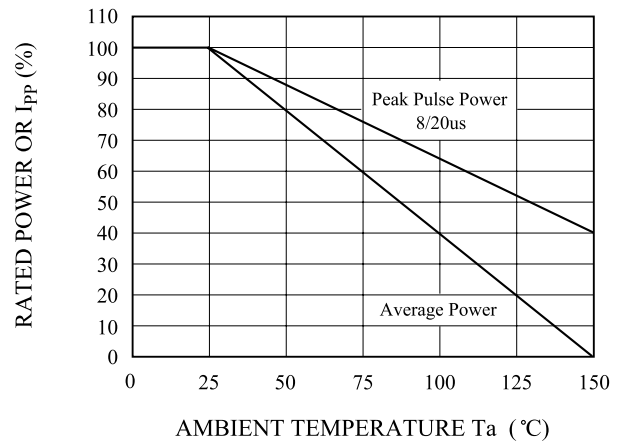

PULSE WAVEFORM

