

Specification For Approval

Customer : GEMINI

Model Type : LCD MODULE

Sample Code : PG320240FRM-CNNIY1

Mass Production Code : PG320240FRM-CNNIY1

Revision : A

Customer Sign	Sales Sign	Checked By	Prepared By

Contents

1. SPECIFICATIONS

- 1.1 FYatures
- 1.2 Mechanical Specifications
- 1.3 Absolute Maximum Ratings
- 1.4 DC Electrical Characteristics
- 1.5 Optical Characteristics
- 1.6 Backlight Characteristics

2. MODULE STRUCTURE

- 2.1 Counter Drawing
- 2.2 Interface Pin Description
- 2.3 Timing Characteristics

3. QUALITY ASSURANCE SYSTEM

- 3.1 Quality Assurance Flow Chart
- 3.2 Inspection Specification

4. RELIABILITY TEST

- 4.1 Reliability Test Condition

5. PRECAUTION RELATING PRODUCT HANDLING

- 5.1 Safety
- 5.2 Handling
- 5.3 Storage
- 5.4 Terms of Warranty

Apprndix A : LCM Drawing.

Note : For detailed information please refer to IC data sheet as below.

Sanyo :LC79430D, LC79401D



POWERTIP TECHNOLOGY CORPORATION
DISPLAY DEVICES FOR BETTER ELECTRONIC DESIGN

1. SPECIFICATIONS

1.1 Features

Item	Standard Value
Display Type	320*240 Dots
LCD Type	STN Blue, Transmissive, Positive, Extended Temp.
Driver Type	1/240 Duty , 1/15 Bias
Viewing Direction	6 O'clock
Backlight	CCFL
Weight	-
Other	4 bits parallel data input, Driver IC: LC79430D, LC79401D

1.2 Mechanical Specifications

Item	Standard Value	Unit
Outline Dimension	150.0 (L) * 96.8 (w) * 16.0 (H)(Max)	mm
Viewing Area	105.0 (L) * 80.0 (w)	mm
Active Area	95.985 (L) * 71.985 (w)	mm
Dot Size	0.285 (L) * 0.285 (w)	mm
Dot Pitch	0.3 (L) * 0.3 (w)	mm

1.3 Absolute Maximum Ratings

Item	Symbol	Condition	Min.	Max.	Unit
Power Supply Voltage	V_{DD}	—	-0.3	7.0	V
LCD Driver Supply Voltage	$V_{DD}-V_{EE}$	—	-	32.0	V
Input Voltage	V_{IN}	—	-0.3	$V_{DD} + 0.3$	V
Operating Temperature	T_{OP}	—	-20	70	°C
Storage Temperature.	T_{ST}	—	-30	80	°C
Humidity	H_D	$T_a < 40^{\circ}C$	20	90	%RH



POWERTIP TECHNOLOGY CORPORATION

DISPLAY DEVICES FOR BETTER ELECTRONIC DESIGN

1.4 DC Electrical Characteristics

$$V_{DD} = 5.0 \text{ V} \pm 10\%, V_{SS} = 0\text{V}, T_a = 25^\circ\text{C}$$

Item	Symbol	Condition	Min.	Typ.	Max.	Unit
Logic Supply Voltage	V_{DD}	—	4.5	5.0	5.5	V
“H” Input Voltage	V_{IH}	—	$0.8 V_{DD}$	-	V_{DD}	V
“L” Input Voltage	V_{IL}	—	V_{SS}	-	$0.2 V_{DD}$	V
“H” Output Voltage	V_{OH}	—	$V_{DD} - 0.4$	-	-	V
“L” Output Voltage	V_{OL}	—	-	-	$V_{SS} + 0.4$	V
Supply Current	I_{DD}	$V_{DD} = 5.0 \text{ V}$	-	2	5	mA
LCD Driver Voltage	V_{OP}	$V_{DD} - V_O (-20^\circ\text{C})$	24.4	24.6	24.8	V
		$V_{DD} - V_O (25^\circ\text{C})$	22.1	22.4	22.7	
		$V_{DD} - V_O (70^\circ\text{C})$	19.8	20.0	20.2	

1.5 Optical Characteristics

$$1/240 \text{ Duty}, 1/15 \text{ Bias}, V_{OP} = 22 \text{ V}, T_a = 25^\circ\text{C}$$

Item	Symbol	Conditions	Min.	Typ.	Max.	Reference
View Angle	θ	$C \geq 2.0, \varnothing = 0^\circ$	-40°	-	40°	Notes 1 & 2
Contrast Ratio	C	$\theta = 5^\circ, \varnothing = 0^\circ$	2	8		Note 3
Response Time(rise)	t_r	$\theta = 5^\circ, \varnothing = 0^\circ$		120 ms	180 ms	Note 4
Response Time(fall)	t_f	$\theta = 5^\circ, \varnothing = 0^\circ$		210ms	315ms	Note 4



Note 1: Definition of angles θ and \varnothing

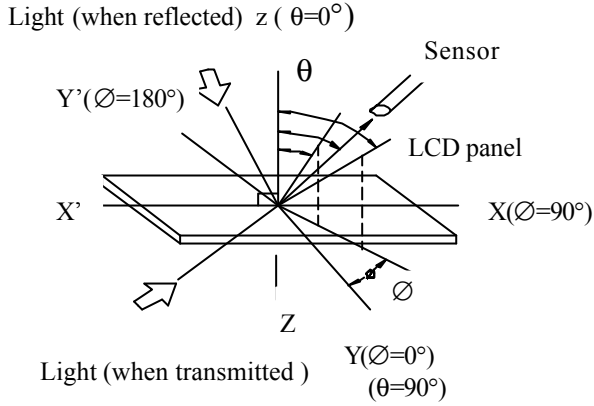

Note 2: Definition of viewing angles θ_1 and θ_2

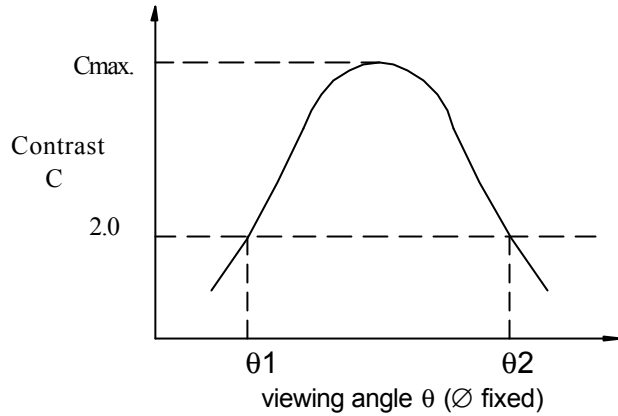

Note : Optimum viewing angle with the naked eye and viewing angle θ at C_{max} . Above are not always the same

Note 3: Definition of contrast C

$$C = \frac{\text{Brightness (reflection) of unselected dot (B2)}}{\text{Brightness (reflection) of selected dot (B1)}}$$

Note 4: Definition of response time

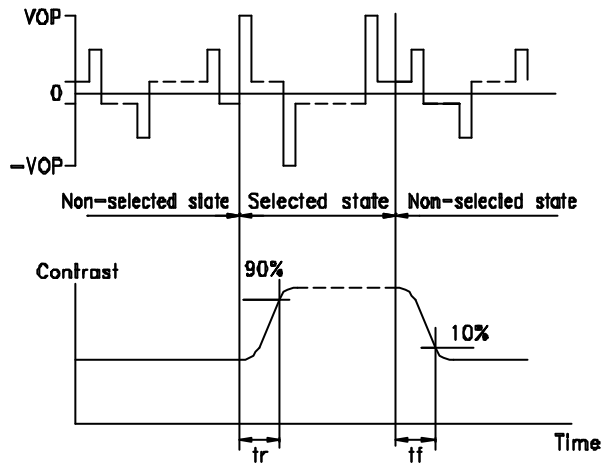
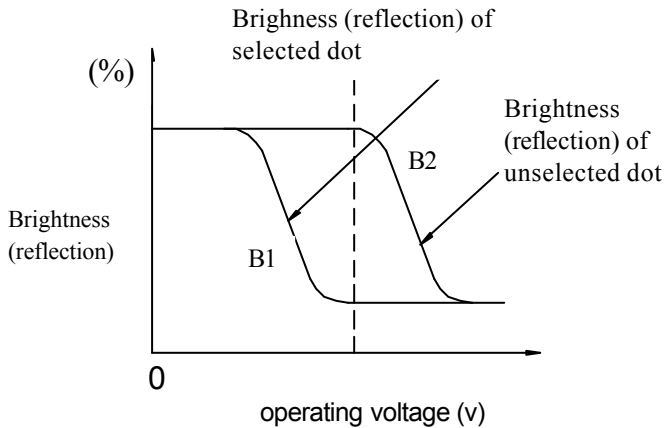

Note: Measured with a transmissive LCD panel which is displayed 1 cm²

V_{OPR} : Operating voltage f_{FRM} : Frame frequency
 t_r : Response time (rise) t_f : Response time (fall)

1.6 Backlight Characteristics

LCD Module with CCFL Backlight

Electrical Characteristics

Item	Spec	Unit	Condition
Start Voltage	600	Vrms	25°C
Tube Voltage	264	Vrms	
Tube Current	5	mA	
Power Consumption	1.8	W	
Driver Frequency	35.87	KHz	
Operating Temperature	0 ~ 60	°C	
Storage Temperature	-30 ~ 80	°C	

Optical Characteristics

Item	Min.	Typ.	Max.	Unit	Condition
Average Brightness (With LCD , Dots Off)	500	700	-	cd/m ²	25°C±2°C 30~85%RH By CXA-K10L-FS2 Inverter
Chromaticity	X	0.323	-	—	
	Y	0.347	-	—	
Average Brightness (With LCD)	-	120	-	cd/m ²	V _{BL} 300 Vrms F _{OSC} 35kHz



1.7 Touch Panel Characteristics

1. Input Method and Activation Force
 - Stylus < 30grams (0.2mm dia. Delrin stylus)
 - Finger <100grams (1.6mm dia. Silicone “finger”)
2. Typical Optical Characteristics
 - Visible Light Transmission : >70%@550nm
3. Electrical Specifications
 1. Operating Voltage 5V or less
 2. Contact current <1.0mA(maximum)
 3. Lead to Lead resistance : < 17k Ω
 4. Circuit open resistance > 10M Ω at 50V DC
 5. Contact bounce < 20ms
4. Touch Screen with 3M Tape
5. Environment Specification
 - Operating Temperature 0°C ~ +50°C (Humidity 20~90% RH)
 - Storage Temperature -25°C ~ +80°C (Humidity 20~95%RH)



2. MODULE STRUCTURE

2.1 Counter Drawing

* See Appendix

2.2 Interface Pin Description

Pin No.	Symbol	Level	Function
1	FLM	H/L	Indicates the beginning of each display cycle.
2	M	H/L	Alternation control signal
3	CL1	H,H→L	The CL1 latches the serial data in the shift registers.
4	CL2	H/L	Clock signal for shifting the serial data.
5	/D-OFF	H/L	Display enable signal. H:ON L:OFF
6	DB0	H/L	Data bit 0 H:ON(White) L: OFF(Black)
7	DB1	H/L	Data bit 1 H:ON(White) L: OFF(Black)
8	DB2	H/L	Data bit 2 H:ON(White) L: OFF(Black)
9	DB3	H/L	Data bit 3 H:ON(White) L: OFF(Black)
10	VDD	+5V	Power supply voltage for logic.
11	VSS	0V	Ground
12	VEE	-	Negative voltage input
13	VO	-	Operating voltage for LCD driving
14	FG	-	Frame ground

Contrast Adjust

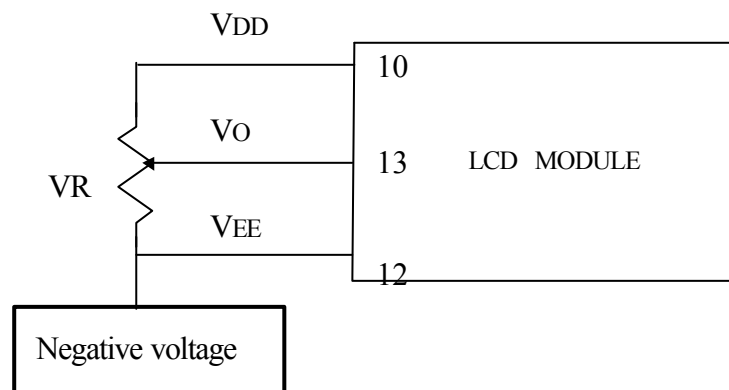

2.3 Timing Characteristics

* SEGMENT DRIVER : LC79401D

Parameter	Symbol	Conditions	min	max	Unit
CL2 (shift clock)	f_{CL2}	CL2	-	6.0	MHZ
CL2 (pulse width)	t_{WC}	CL2	50	-	ns
CL1 (pulse width)	t_{WL}	CL1	50	-	ns
Setup Time	t_{SETUP}	DB0 to DB3→CL2	30	-	ns
Hold Time	t_{HOLD}	DB0 to DB3→CL2	30	-	ns
CL2→CL1	t_{CL}	CL2→CL1	80	-	ns
CL1→CL2	t_{LC}	CL1→CL2	110	-	ns
CL2 and CL1 Rise Time	t_R	CL2,CL1	-	50	ns
CL2 and CL1 Fall Time	t_F	CL2,CL1	-	50	ns
Output Delay Time	t_D	Load = 15pF ; CDO		80	ns

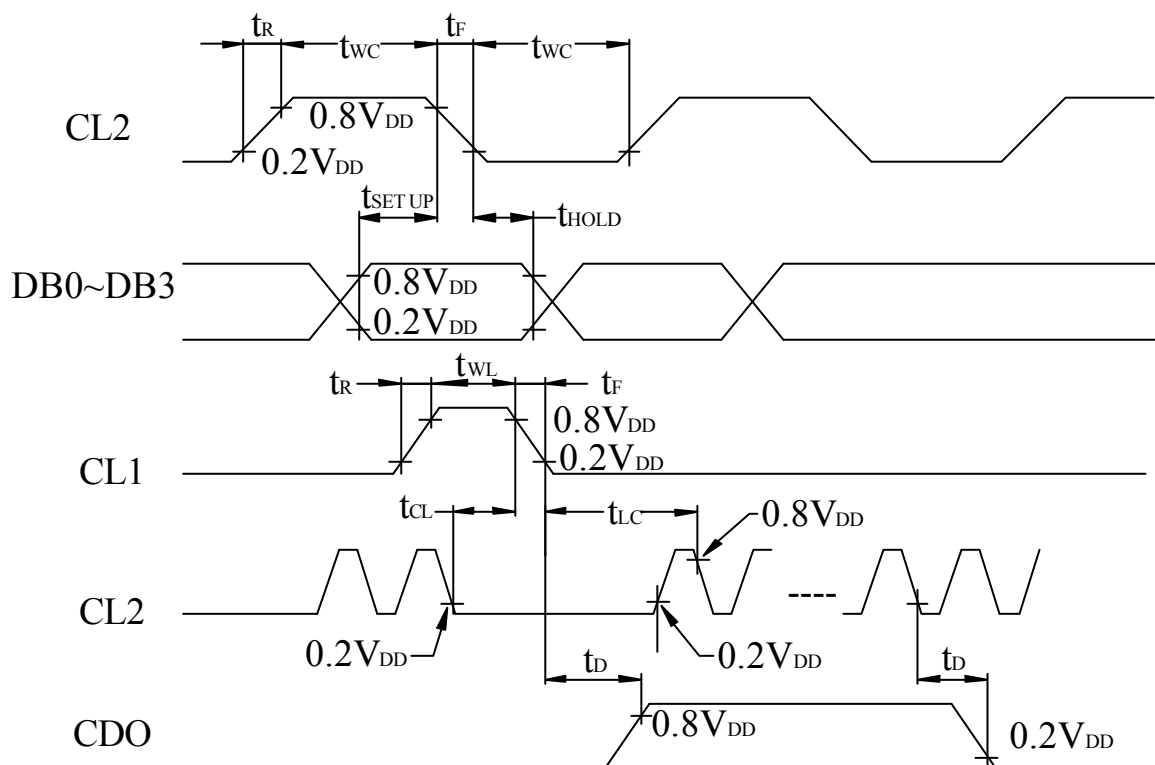

POWERTIP TECHNOLOGY CORPORATION

DISPLAY DEVICES FOR BETTER ELECTRONIC DESIGN

* COMMON DRIVER : LC79430D

Parameter	Symbol	Conditions	min	max	Unit
CL1 (shift clock)	f_{CL1}	CL1	-	1.0	MHz
CL1 (pulse width)	t_{WC}	CL1	63	-	ns
Setup Time	t_{SETUP}	DIO1→CL1,DIO80→CL1 DMIN→CL1	100	-	ns
Hold Time	t_{HOLD}	DIO1→CL1,DIO80→CL1 DMIN→CL1	100	-	ns
CL1 Rise Time	t_R	CL1	-	50	ns
CL1 Fall Time	t_F	CL1	-	50	ns
Output Delay Time	t_{PLH}	$C_L = 15pF$; CL1→DIO1,CL1→DIO80	-	250	ns
Output Delay Time	t_{PHL}	$C_L = 15pF$; CL1→DIO1,CL1→DIO80	-	250	ns

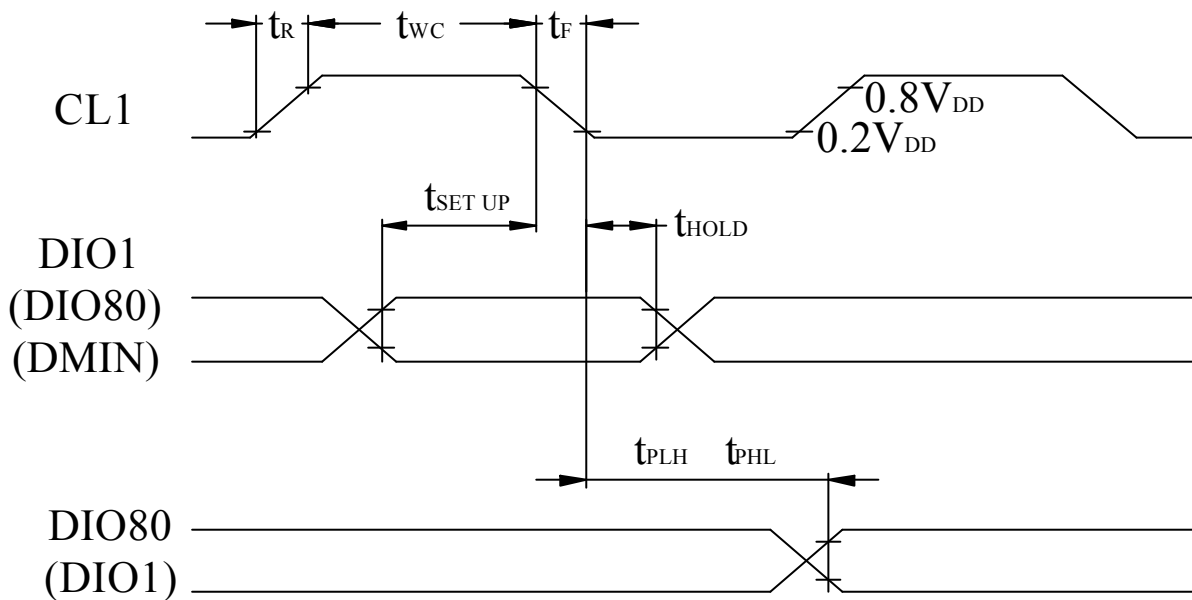

POWERTIP TECHNOLOGY CORPORATION

DISPLAY DEVICES FOR BETTER ELECTRONIC DESIGN

3. QUALITY ASSURANCE SYSTEM

3.1 Quality Assurance Flow Chart

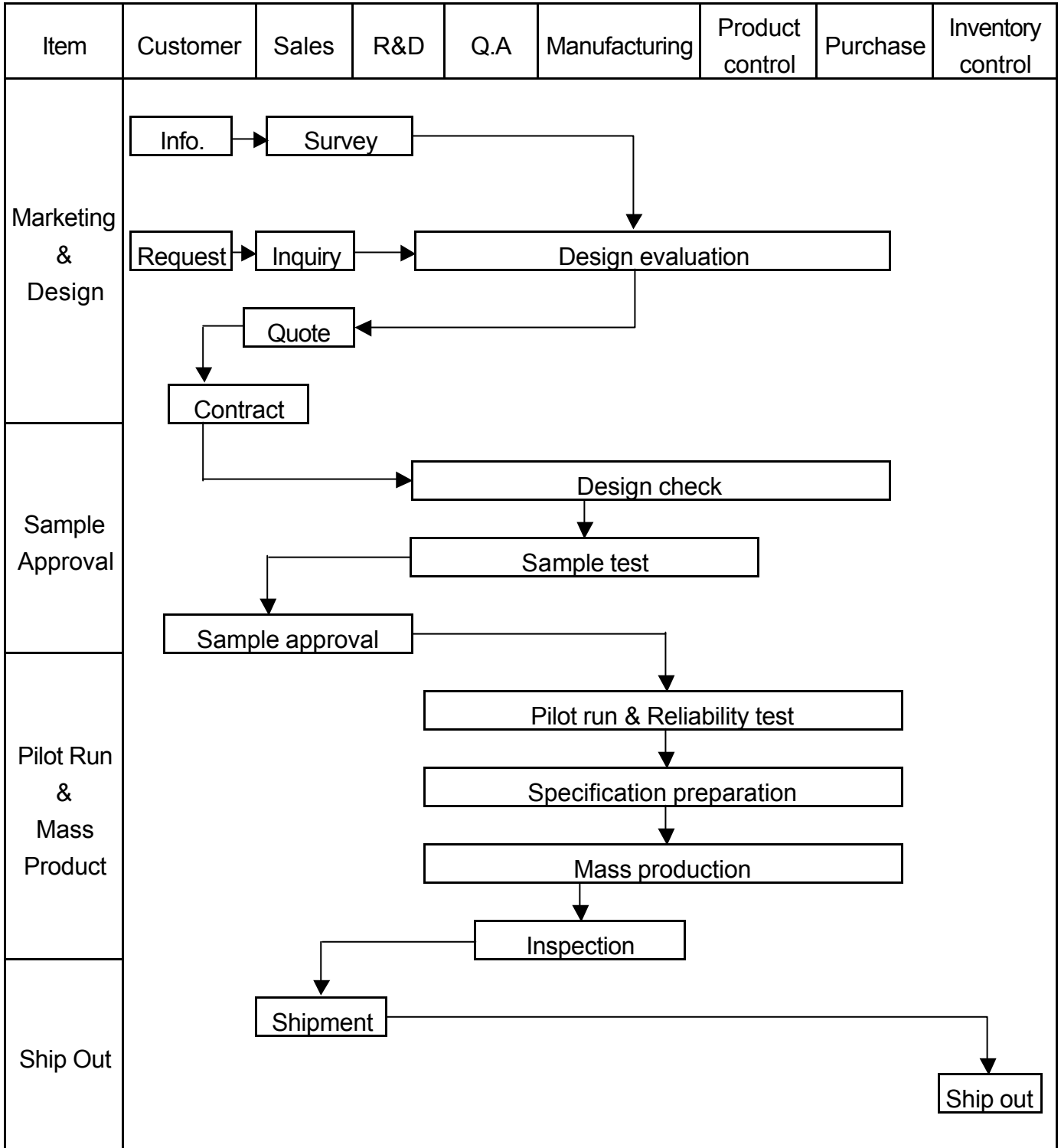

<p>Sales Service</p>	<pre> graph TD Info[Info.] --> Claim[Claim] Claim --> Failure[Failure analysis] Failure --> Report[Analysis report] Failure --> Action[Corrective action] Action --> Tracking[Tracking] </pre>
<p>Q.A Activity</p>	<p>1. ISO 9001 Maintenance Activities 2. Process improvement proposal 3. Equipment calibration 4. Education And Training Activities 5. Standardization Management</p>

3.2 Inspection Specification

Inspection Standard : MIL-STD-105E Table Normal Inspection Single Sampling Level II ◦

Equipment : Gauge 、 MIL-STD 、 Powertip Tester 、 Sample ◦

IQC Defect Level : Major Defect AQL 0.65; Minor Defect AQL 1.0 ◦

FQC Defect Level : 100% Inspection ◦

OUT Going Defect Level : Sampling ◦

Specification :

NO	Item	Specification	Judge	Level
1	Part Number	Inconsistent with the P/N on the flow chart of production	N.G.	Major
2	Quantity	Inconsistent Q'TY with the flow chart of production	N.G.	Major
3	Electronic characteristics A=(L + W) ÷ 2	Display short	N.G.	Major
		Missing line	N.G.	Major
		Dot missing A > 1/2 Dot size	N.G.	Major
		No function	N.G.	Major
		Out put data error	N.G.	Major
4	Appearance A=(L + W) ÷ 2	Material difference with flow chart	N.G.	Major
		LCD Assembled in opposite direction	N.G.	Major
		Bezel assembled in opposite direction	N.G.	Major
		Shadow within LCD V./A + 1.0 mm	N.G.	Major
	Dirty particle (Include scratch 、 bubble)	Dirty particle A > 0.4 mm	N.G.	Minor
		Dirty particle length > 3.0mm And 0.01mm < Width ≤ 0.05mm (Width > 0.05mm Measure by area)	N.G.	Minor
		Without protective film	N.G.	Minor
		Conductive rubber over bezel	N.G.	Minor
5	PCB Appearance A=(L + W) ÷ 2	Burned PCB	N.G.	Major
		Green paint stripped & visible circuit A > 1.0mm (Finish coat not counted in)	N.G.	Minor
		A particle across the circuit	N.G.	Minor
		Circuit split > 1/2 Circuit width	N.G.	Minor
		Any circuit risen	N.G.	Minor
		0.2mm < Tin ball area A ≤ 0.4mm And Q'TY > 4 Pieces	N.G.	Minor
		Tin ball area A > 0.4mm	N.G.	Minor

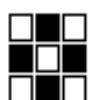

POWERTIP TECHNOLOGY CORPORATION

DISPLAY DEVICES FOR BETTER ELECTRONIC DESIGN

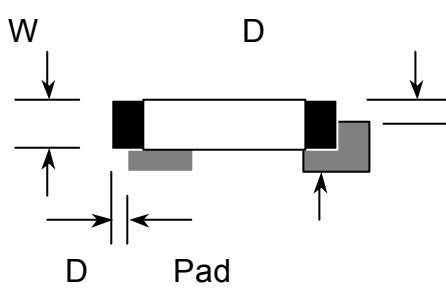
NO	Item	Specification	Judge	Level
6	Molding appearance $A=(L+W)\div 2$	Too soft : Shape by touch changed	N.G.	Major
		Insufficient epoxy : IC circuit or IC pad visible	N.G.	Minor
		Excessive epoxy : Diameter > 20mm Or High > 2.5mm	N.G.	Minor
		Pin hole through to IC and $A > 0.2\text{mm}$	N.G.	Minor
7	Bezel appearance $A=(L+W)\div 2$	Angle between frame and TAB > $45^\circ + 10^\circ$	N.G.	Minor
		Electroplate strip $A > 1.0\text{mm}$ (Top view only)	N.G.	Minor
		Rust (Top view only)	N.G.	Minor
		Crack	N.G.	Minor
8	Backlight electric characteristics $A=(L+W)\div 2$	Error backlight color	N.G.	Major
		No function	N.G.	Major
		Any LED dot no function	N.G.	Major
		PIN soldering without tin $A > 1/2$ solder pad	N.G.	Minor
		Solder PIN high > 1.5mm	N.G.	Minor
9	LCD Appearance $A=(L+W)\div 2$	Polarize rise over V/A	N.G.	Minor
10	Assembly parts $A=(L+W)\div 2$	Components mark unclearly	N.G.	Minor
		Components' distance more than 0.7mm from the PCB	N.G.	Minor
		Error position ,not in center $D > 1/4W$	N.G.	Minor
				
		Non- solder area > Twice solder area	N.G.	Minor
		Flux area $A > 1/4$ solder area	N.G.	Minor
		Component broken	N.G.	Minor



4. RELIABILITY TEST

4.1 Reliability Test Condition

NO	Item	Test Condition		Applicable Standard
1	High Temperature Storage	Storage At $80 \pm 2^{\circ}\text{C}$ 96~100 hrs Surrounding Temperature , Then Storage At Normal Condition 4hrs.		MIL-202E
2	Low Temperature Storage	Storage At $-30 \pm 2^{\circ}\text{C}$ 96~100 hrs Surrounding Temperature, Then Storage At Normal Condition 4hrs.		MIL-202E
3	High Temperature Humidity Storage	1.Storage 96~100 hrs $60 \pm 2^{\circ}\text{C}$, 90~95%RH Surrounding Temperature, Then Storage At Normal Condition 4hrs .(Polarizer may fail in this environment). or 2.Storage 96~100 hrs $40 \pm 2^{\circ}\text{C}$, 90~95%RH Surrounding Temperature, Then Storage At Normal Condition 4 hrs.		MIL-202E
4	Temperature Cycling	$-20^{\circ}\text{C} \rightarrow 25^{\circ}\text{C} \rightarrow 70^{\circ}\text{C} \rightarrow 25^{\circ}\text{C}$ (30Mins) (5Mins) (30Mins) (5Mins) 10 Cycle		MIL-202E
5	Vibration	10~55Hz (1 Minute) 1.5mm X,Y And Z Direction * (Each 2hrs)		MIL-202E
6	Drop Test	Packing Weight (Kg)	Drop High (Cm)	MIL-810E
		0 ~ 45.4	122	
		45.4 ~ 90.8	76	
		90.8 ~ 454	61	
		Over 454	46	



POWERTIP TECHNOLOGY CORPORATION

DISPLAY DEVICES FOR BETTER ELECTRONIC DESIGN

5. PRECAUTION RELATING PRODUCT HANDLING

5.1 SAFETY

5.1.1 If the LCD panel breaks , be careful not to get the liquid crystal to touch your skin.

5.1.2 If the liquid crystal touches your skin or clothes , please wash it off immediately by using soap and water.

5.2 HANDLING

5.2.1 Avoid any strong mechanical shock which can break the glass.

5.2.2 Avoid static electricity which can damage the CMOS LSI—When working with the module , be sure to ground your body and any electrical equipment you may be using.

5.2.3 Do not remove the panel or frame from the module.

5.2.4 The polarizing plate of the display is very fragile. So , please handle it very carefully , do not touch , push or rub the exposed polarizing with anything harder than an HB pencil lead (glass , tweezers , etc.)

5.2.5 Do not wipe the polarizing plate with a dry cloth , as it may easily scratch the surface of plate.

5.2.6 Do not touch the display area with bare hands , this will stain the display area.

5.2.7 Do not use ketonics solvent & aromatic solvent. Use with a soft cloth soaked with a cleaning naphtha solvent.

5.3 STORAGE

5.3.1 Store the panel or module in a dark place where the temperature is $25^{\circ}\text{C} \pm 5^{\circ}\text{C}$ and the humidity is below 65% RH.

5.3.2 Do not place the module near organics solvents or corrosive gases.

5.3.3 Do not crush , shake , or jolt the module.

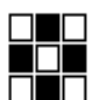

5.4 TERMS OF WARRANTY

5.4.1 Applicable warrant period

The period is within ten months since the date of shipping out under normal using and storage conditions.

5.4.2 Unaccepted responsibility

This product has been manufactured to your company's specification as a part for use in your company's general electronic products. It is guaranteed to perform according to delivery specifications. For any other use apart from general electronic equipment , we cannot take responsibility if the product is used in medical devices , nuclear power control equipment , aerospace equipment , fire and security systems or any other applications in which there is a direct risk to human life and where extremely high levels of reliability are required.



POWERTIP TECHNOLOGY CORPORATION

DISPLAY DEVICES FOR BETTER ELECTRONIC DESIGN

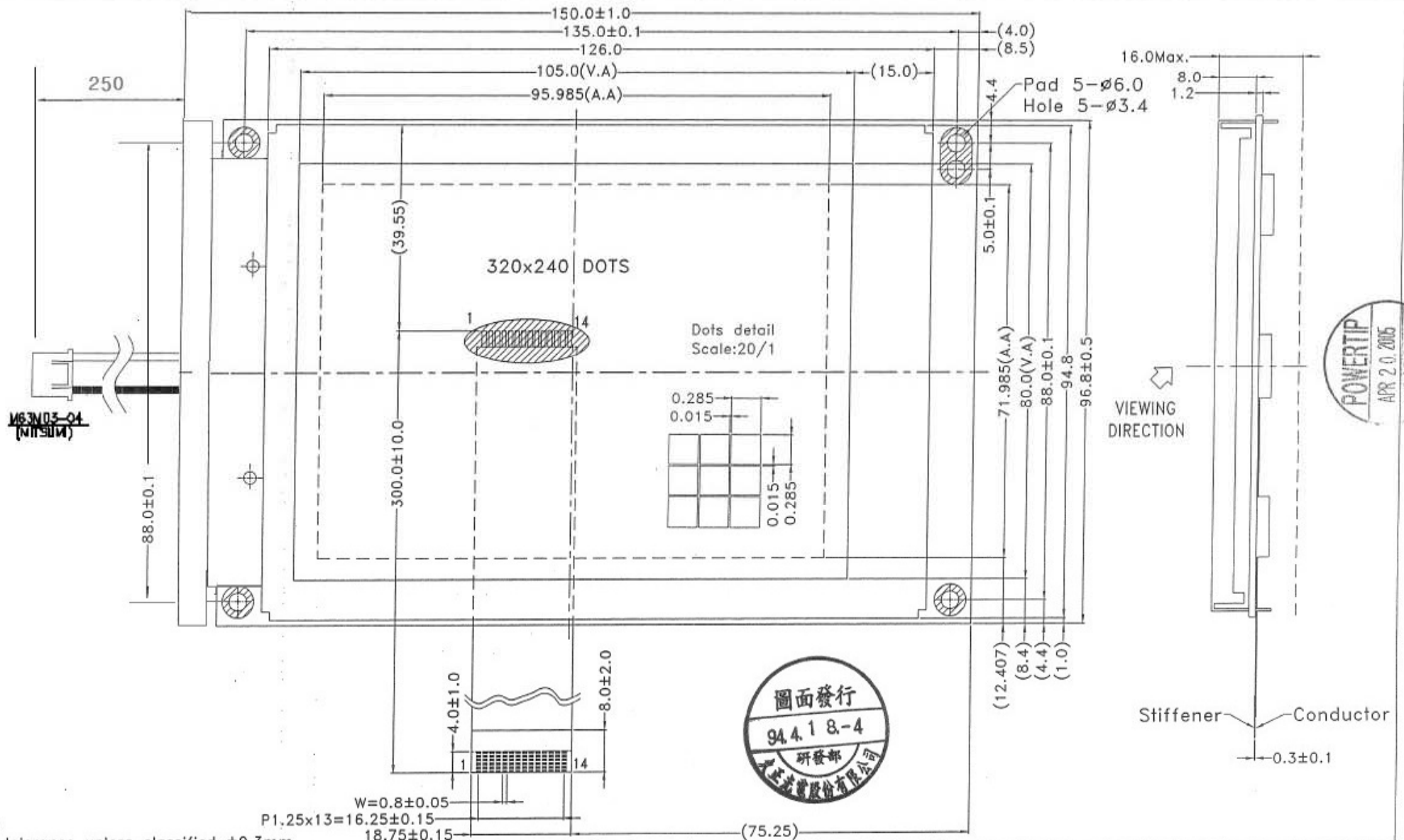

- NOTE:
- 1.The tolerance unless classified $\pm 0.3\text{mm}$
 - 2.View direction: 6 o'clock
 3. UV Glue area
 - 4.LCD type:STN
 - 5.LCD mode: Negative / Transmissive
 6. $T_{op} = -20^{\circ}\text{C} \sim 70^{\circ}\text{C}$, $T_{st} = -30^{\circ}\text{C} \sim 80^{\circ}\text{C}$

REV	DESCRIPTION	DATE



久正光電股份有限公司 POWER TIP TECHNOLOGY CORPORATION						
SCALE:1/1	UNIT:mm	PAGE:1/1	APPROVED	CHECKER	DRAWN	
圖面名稱	PG320240WRM-CNNIY1		研發 2005-4-18	發 2005-4-18 李美倫	研發 2005-4-18 黃証淋	
圖面編號	PG-03099-010	EDI 0	廖志堯	李美倫	黃証淋	

