

SPECIFICATIONS

CUSTOMER : _____



SAMPLE CODE : _____

(This Code will be changed while mass production)

MASS PRODUCTION CODE : **PG640480FRT-ANN-I**

Customer Approved

Date: _____

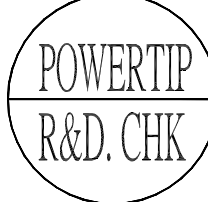
Sales Sign	QC Confirmed	Checked By	Designer
			

Approval For Specifications Only.

* This specification is subject to change without notice.

Please contact Powertip or it's representative before designing your product based on this specification.

Approval For Specifications and Sample.

Powertip Corporation

Headquarters:

No.8, 6th Road, Taichung Industrial Park,

Taichung, Taiwan

台中市 407 工業區六路 8 號

LCD Division:

TEL: 886-4-2355-6888

FAX: 886-4-2355-6898

E-mail: sales@display.powertip.com.tw

Http://www.powertip.com.tw

LCM Division:

TEL: 886-4-2355-8168

FAX: 886-4-2355-8166

E-mail: sales@mail.powertip.com.tw

Http://www.powertip.com.tw

RECORDS OF REVISION

Date	Rev.	Description	Note	Page
2003/04/21	0	Mass Production		

Total : 18 Page

Contents

1. SPECIFICATIONS

- 1.1 Features**
- 1.2 Mechanical Specifications**
- 1.3 Absolute Maximum Ratings**
- 1.4 DC Electrical Characteristics**
- 1.5 Optical Characteristics**
- 1.6 Backlight Characteristics**

2. MODULE STRUCTURE

- 2.1 Counter Drawing**
- 2.2 Interface Pin Description**
- 2.3 Timing Characteristics**

3. QUALITY ASSURANCE SYSTEM

- 3.1 Quality Assurance Flow Chart**
- 3.2 Inspection Specification**

4. RELIABILITY TEST

- 4.1 Reliability Test Condition**

5. PRECAUTION RELATING PRODUCT HANDLING

- 5.1 Safety**
- 5.2 Handling**
- 5.3 Storage**
- 5.4 Terms of Warranty**

1. SPECIFICATIONS

1.1 Features

Item	Standard Value
Display Type	640*480 Dots
LCD Type	FSTN, Negative, Transmissive
Driver Condition	LCD Module : 1/240 Duty , 1/13Bias
Viewing Direction	6 O'clock
Backlight	CCFL B/L
Weight	260g
Interface	Dual 4 bits parallel data input
Other(controller/driver IC)	—

1.2 Mechanical Specifications

Item	Standard Value	Unit
Outline Dimension	197.0 (L) * 145.0 (w) * 11.0 (H)(Max)	mm
Viewing Area	153.0 (L) * 115.74 (w)	mm
Active Area	151.66 (L) * 113.74 (w)	mm
Dot Size	0.217 (L) * 0.217 (w)	mm
Dot Pitch	0.237 (L) * 0.237 (w)	mm

Note : For detailed information please refer to LCM drawing

1.3 Absolute Maximum Ratings

Item	Symbol	Condition	Min.	Max.	Unit
Power Supply Voltage	V_{DD}	—	0	6.0	V
LCD Driver Supply Voltage	$V_{DD}-V_{EE}$	—	0	45	V
Input Voltage	V_{IN}	—	-0.3	$V_{DD}+0.3$	V
Operating Temperature	T_{OP}	Excluded B/L	-20	70	°C
Storage Temperature.	T_{ST}	Excluded B/L	-30	80	°C
Storage Humidity	H_D	$T_a < 40\text{ }^{\circ}\text{C}$	20	60	%RH

1.4 DC Electrical Characteristics

$V_{DD} = 5.0 \text{ V} \pm 10\%$, $V_{SS} = 0\text{V}$, $T_a = 25^\circ\text{C}$

Item	Symbol	Condition	Min.	Typ.	Max.	Unit
Logic Supply voltage	V_{DD}	-	3.0	5.0	5.5	V
“H” input voltage	V_{IH}	-	$0.8 V_{DD}$	-	V_{DD}	V
“L” input voltage	V_{IL}	-	0	-	$0.2 V_{DD}$	V
“H” output voltage	V_{OH}	$I_{OH} = -0.4\text{mA}$	$V_{DD} - 0.3$	-	0.3	V
“L” output voltage	V_{OL}	$I_{OL} = +0.4\text{mA}$	0	-	0.4	V
Supply current	I_{DD}	$V_{DD} = 5\text{V}$	-	3	-	mA
LCM Driver Voltage	V_{OP}	$V_{DD} - V_O (0^\circ\text{C})$	-	23.5	-	V
		$V_{DD} - V_O (25^\circ\text{C})$	-	22.3	-	
		$V_{DD} - V_O (50^\circ\text{C})$	-	20.5	-	

1.5 Optical Characteristics

LCD Panel : 1/240 Duty , 1/13 Bias , $V_{LCD} = 22.3\text{V}$, $T_a = 25^\circ\text{C}$

Item	Symbol	Conditions	Min.	Typ.	Max.	Reference
View Angle	θ	$C \geq 2.0, \varnothing = 0^\circ$	-22°	-	37°	Notes 1 & 2
Contrast Ratio	C	$\theta = 5^\circ, \varnothing = 0^\circ$	-	4	-	Note 3
Response Time(rise)	t_r	$\theta = 5^\circ, \varnothing = 0^\circ$	-	150 ms	-	Note 4
Response Time(fall)	t_f	$\theta = 5^\circ, \varnothing = 0^\circ$	-	200 ms	-	Note 4
Luminance (LCM)	L	-	100	120	-	Cd/m^2

Note 1: Definition of angles θ and \varnothing

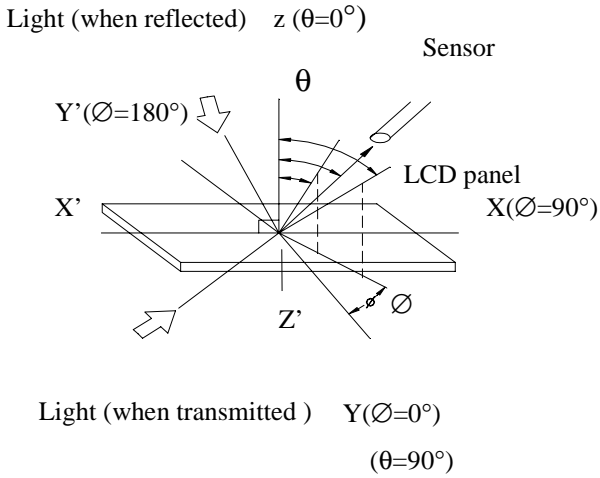

Note 2: Definition of viewing angles θ_1 and θ_2

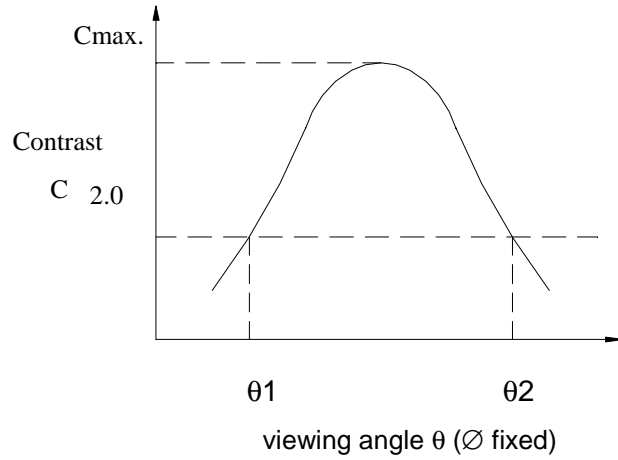

Note : Optimum viewing angle with the naked eye and viewing angle θ at $C_{max.}$ Above are not always the same

Note 3: Definition of contrast C

$$C = \frac{\text{Brightness (reflection) of unselected dot (B2)}}{\text{Brightness (reflection) of selected dot (B1)}}$$

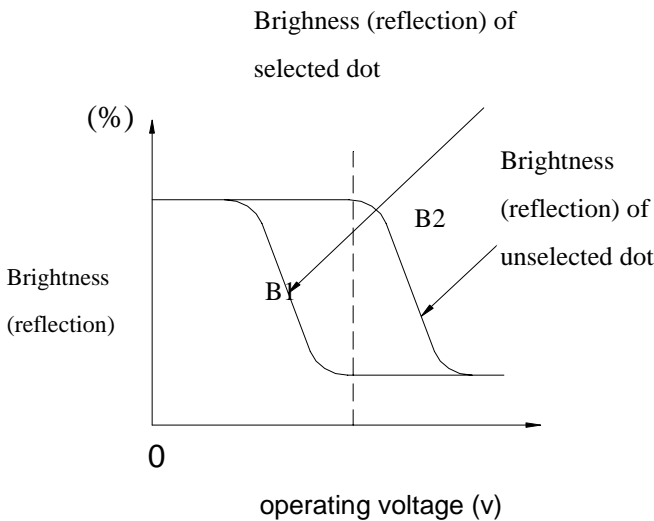

Note 4: Definition of response time

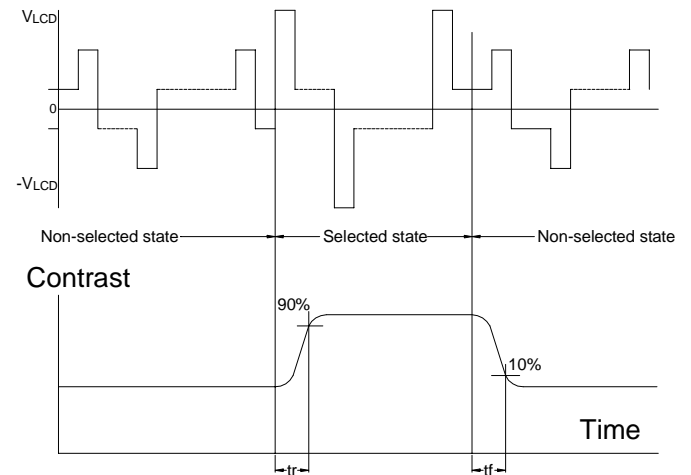

Note: Measured with a transmissive LCD panel which is displayed 1 cm^2

V_{LCD} : Operating voltage f_{FRM} : Frame frequency

t_r : Response time (rise) t_f : Response time (fall)

1.6 Backlight Characteristics

LCD Module with CCFL Backlight

Electrical Characteristics

Item	Symbol	Conditions	Spec	Unit	
Lamp current	I_L	Ta=25°C	5 ± 1.0	mA _{rms}	
Lamp voltage	V_L	Ta=25°C	295	V _{rms}	
Lamp Frequency	F_L	Ta=25°C	55	KHz	
Lamp Power	P_L	Ta=25°C	1.5	W _{rms}	
Lamp Life Time	Hr	> 15,000 Hour			
Operating Temperature	T _{OP}	20~90%RH	0	60	°C
Storage temperature	T _{ST}	5~90%RH	-30	70	°C

Optical Characteristics

Item	Symbol	Condition	Min.	Typ.	Max.	Unit
Average Brightness (With LCD)	IV	Note1	-	233	-	cd/m ²
Brightness Uniformity	-	Note1	70%	85%	100%	
Color	White					

Note1 : Inverter use TDK CXA-L10A (Power Supply 5.0V) at Ta=25°C

2. MODULE STRUCTURE

2.1 Counter Drawing

* See Appendix

2.2 Interface Pin Description

LCM Connector : MOLEX 53261-1590

Pin No.	Symbol	Level	Function
1	FLM	H	The FLM signal indicating the beginning of each display cycle
2	LP	H->L	Display data latch pulse
3	CL2	H->L	Display data shift clock
4	/DISP	H/L	'H' : Display ON ; 'L' : Display OFF
5	VDD		Power supply for logic circuit
6	VSS		Ground
7	VEE		Contrast adjustment voltage , VEE-VSS=22.5 V at 25°C
8~11	UD0~UD3	H/L	Upper Screen Display data
12~15	LD0~LD3	H/L	Lower Screen Display data

Mating connector :

MOLEX 51021-1500(HOUSING)*1 + MOLEX 50058-8000(TERMINAL)*15

CCFL Connector : MITSUMI : M63-M83-04

Interface	Pin	Signal	Function
CCFL Back Light	1	VCCFL	Power supply for CCFL back light
	2~3	NC	No connection
	4	VCCFL	Power supply for CCFL back light

Mating connector :

MITSUMI : M61M73-04/M60-04-30-114P(STRAIGHT)/ M60-04-30-134P(ANGLE)

2.3 Timing Characteristics

ITEM	Symbol	TEST CONDITIONS	Min	Max	Units
Clock Cycle	t_c	-	125	-	ns
CL2 Pulse Width	$T_{cwh} \cdot t_{cwl}$	-	50	-	ns
DATA Set-up Time	t_{DSU}	-	50	-	ns
DATA Hold Time	t_{DHD}	-	50	-	ns
CL2 Rise/Fall Time	t_r, t_f	-	-	(*5)	ns
LP Rise Time	t_{LRP}	-	50	-	ns
LP Fall Time	t_{LFP}	-	50	-	ns
LP Pulse Width	t_{LW}	-	45	-	ns
CL2-to-LP Delay Time	t_{SL}	-	40	-	ns
LP-to- CL2 Delay Time	t_{LS}	-	40	-	ns
EIO-in Fall Time	t_{EIFP}	-	40	-	ns
EIO-in Pulse Width	t_{EIW}	-	40	-	ns
CL2-to-EIP Delay Time	t_{SE}	-	20	-	ns
EIO-out Delay Time	t_{EOD}	(*6)	-	80	ns

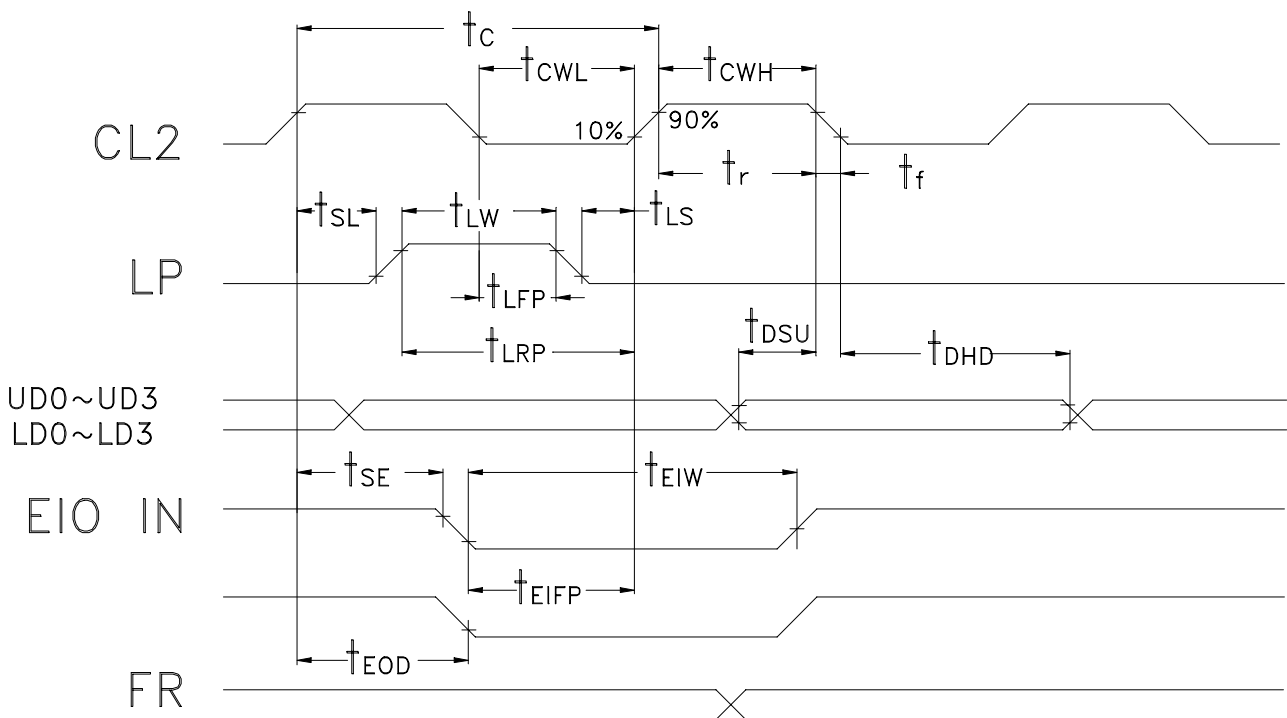

POWER SUPPLY

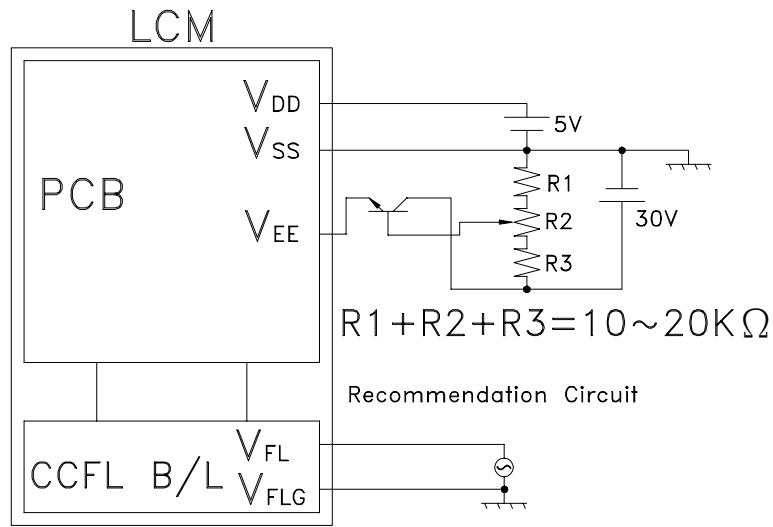

BLOCK DIAGRAM

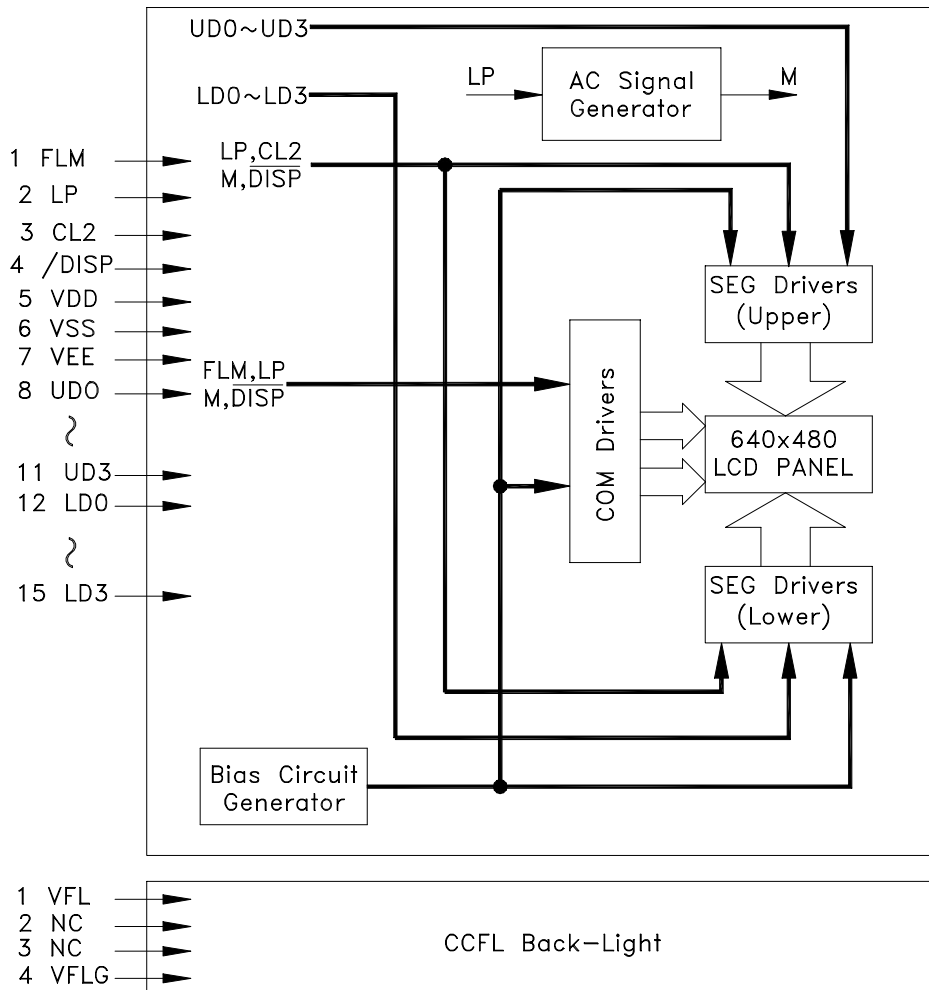

DISPLAY PATTERN

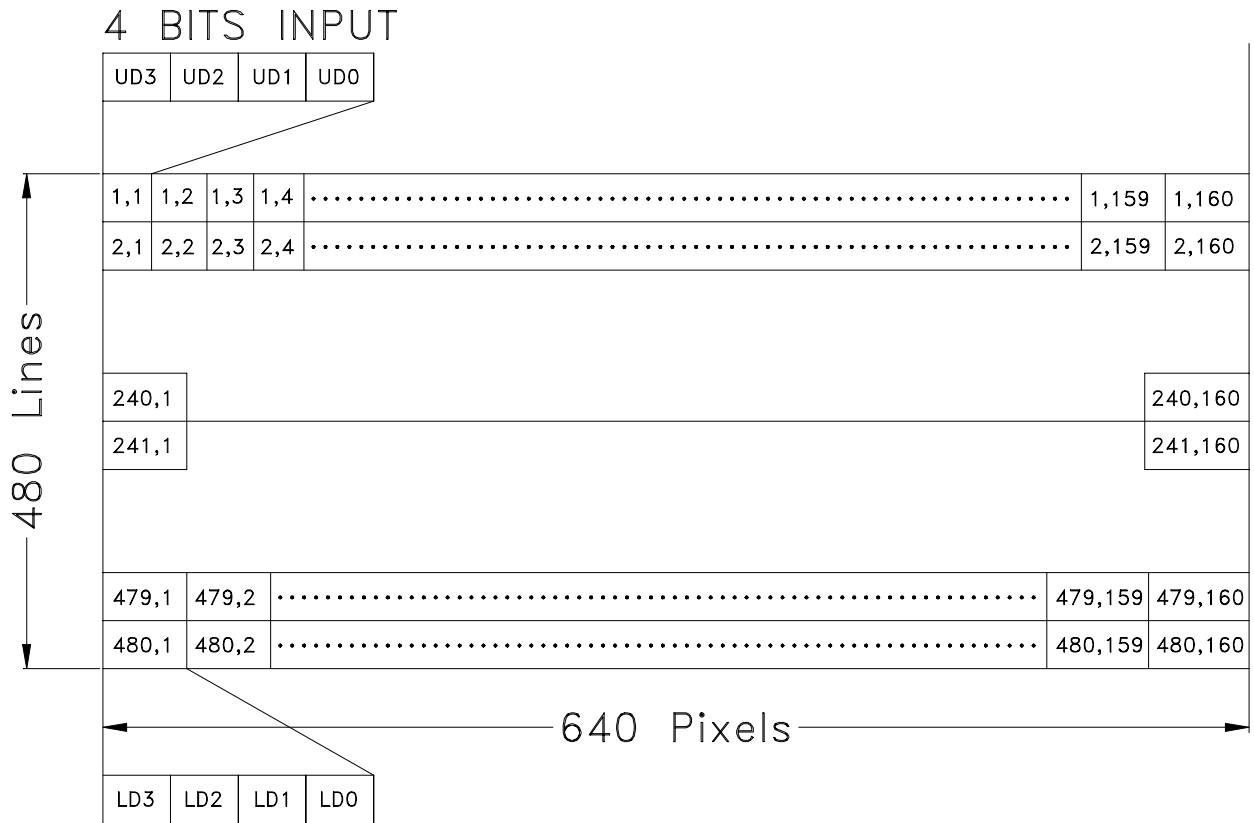

3. QUALITY ASSURANCE SYSTEM

3.1 Quality Assurance Flow Chart

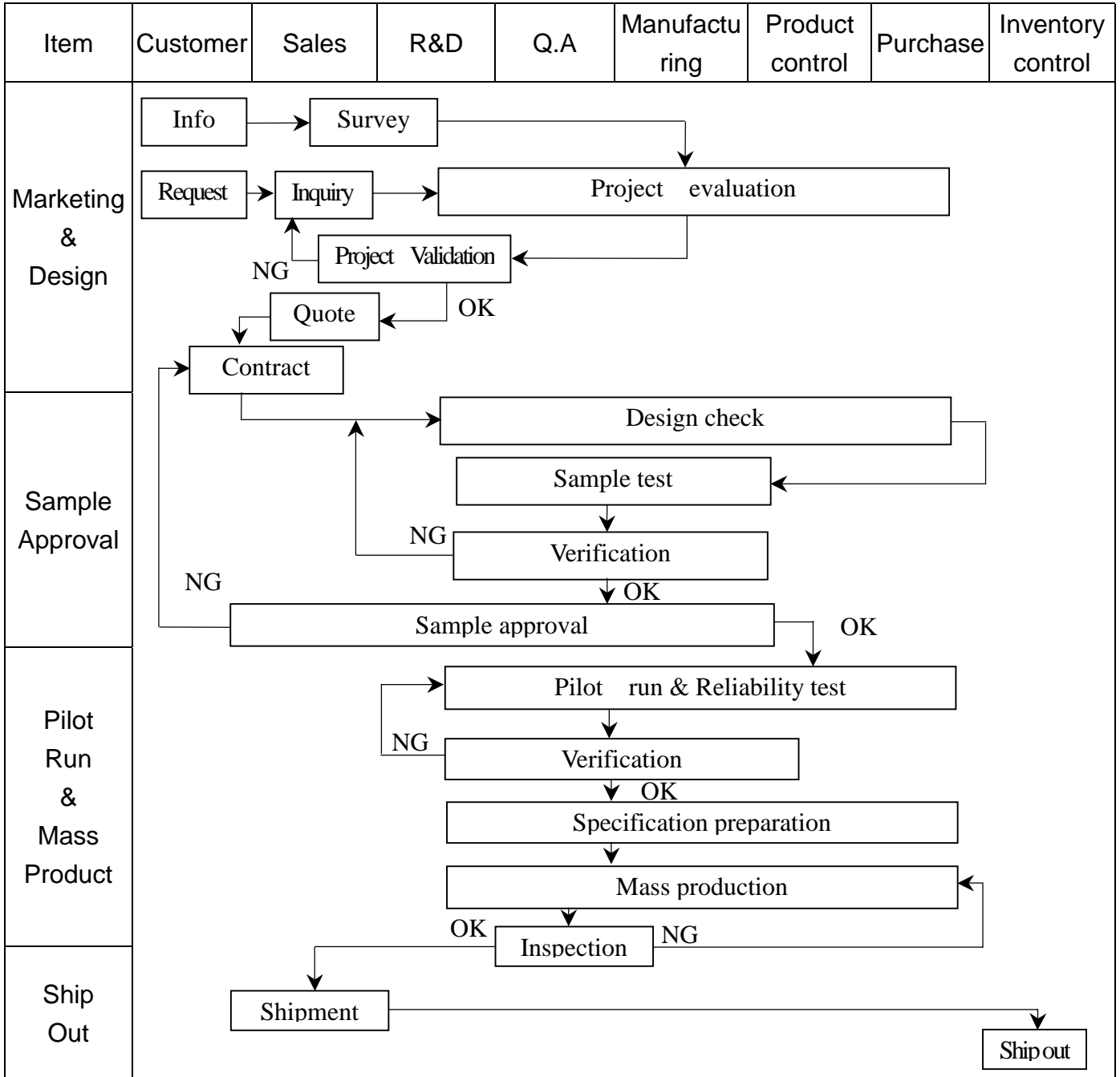

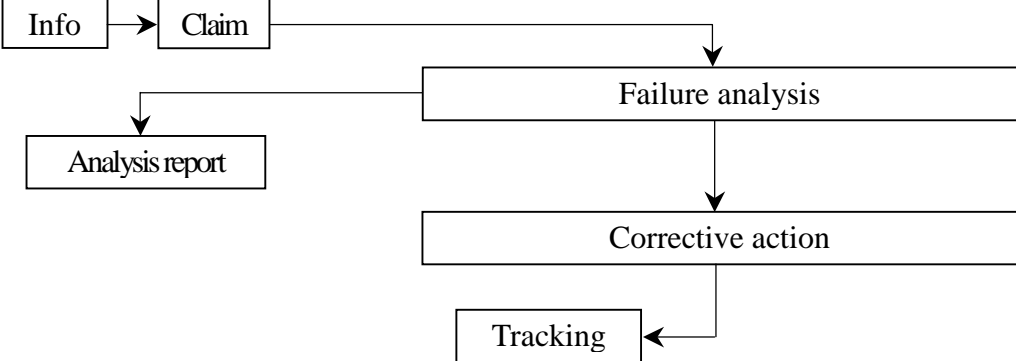
Item	Customer	Sales	R&D	Q.A	Manufacturing	Product control	Purchase	Inventory control
Sales Service	 <pre> graph TD Info[Info] --> Claim[Claim] Claim --> Failure[Failure analysis] Failure --> Report[Analysis report] Failure --> Action[Corrective action] Action --> Tracking[Tracking] </pre>							
Q.A Activity	1. ISO 9001 Maintenance Activities 3. Equipment calibration 5. Standardization Management				2. Process improvement proposal 4. Education And Training Activities			

3.2 Inspection Specification

Inspection Standard : MIL-STD-105E Table Normal Inspection Single Sampling Level II ◦

Equipment : Gauge 、 MIL-STD 、 Powertip Tester 、 Sample ◦

IQC Defect Level : Major Defect AQL 0.4; Minor Defect AQL 1.5 ◦

FQC Defect Level : 100% Inspection ◦

OUT Going Defect Level : Sampling ◦

Specification :

NO	Item	Specification	Judge	Level
1	Part Number	The part number is inconsistent with work order of production	N.G.	Major
2	Quantity	The quantity is inconsistent with work order of production	N.G.	Major
3	Electronic characteristics of LCM $A = (L + W) \div 2$	The display lacks of some patterns.	N.G.	Major
		Missing line.	N.G.	Major
		The size of missing dot, A is $> 1/2$ Dot size	N.G.	Major
		There is no function.	N.G.	Major
		Output data is error	N.G.	Major
4	Appearance of LCD $A = (L + W) \div 2$	Material is different with work order of production	N.G.	Major
		LCD is assembled in inverse direction	N.G.	Major
		Bezel is assembled in inverse direction	N.G.	Major
		Shadow is within LCD viewing area + 0.5 mm	N.G.	Major
		The diameter of dirty particle, A is > 0.4 mm	N.G.	Minor
	Dirty particle (Including scratch 、 bubble)	Dirty particle length is > 3.0 mm, and 0.01 mm $<$ width ≤ 0.05 mm	N.G.	Minor
		Display is without protective film	N.G.	Minor
		Conductive rubber is over bezel 1mm	N.G.	Minor
		Polarizer exceeds over viewing area of LCD	N.G.	Minor
		Area of bubble in polarizer, $A > 1.0$ mm, the number of bubble is > 1 piece.	N.G.	Minor
		0.4 mm $<$ Area of bubble in polarizer, $A < 1.0$ mm, the number of bubble is > 4 pieces.	N.G.	Minor
5	Appearance of PCB $A = (L + W) \div 2$	Burned area or wrong part number is on PCB	N.G.	Major
		The symbol, character, and mark of PCB are unidentifiable.	N.G.	Minor
		The stripped solder mask , A is > 1.0 mm	N.G.	Minor
		0.3 mm $<$ stripped solder mask or visible circuit, A < 1.0 mm, and the number is ≥ 4 pieces	N.G.	Minor
		There is particle between the circuits in solder mask	N.G.	Minor
		The circuit is peeled off or cracked	N.G.	Minor
		There is any circuits risen or exposed.	N.G.	Minor
		0.2 mm $<$ Area of solder ball, A is ≤ 0.4 mm	N.G.	Minor
		The number of solder ball is ≥ 3 pieces	N.G.	Minor
		The magnitude of solder ball, A is > 0.4 mm.	N.G.	Minor

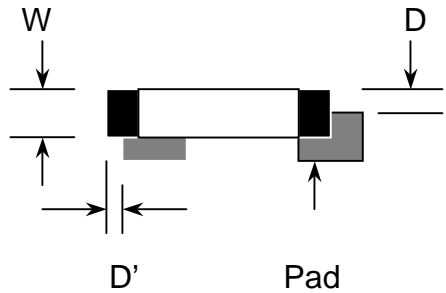
NO	Item	Specification	Judge	Level
6	Appearance of molding $A=(L+W) \div 2$	The shape of modeling is deformed by touching.	N.G.	Major
		Insufficient epoxy: Circuit or pad of IC is visible	N.G.	Minor
		Excessive epoxy: Diameter of modeling is $>20\text{mm}$ or height is $>2.5\text{mm}$	N.G.	Minor
		The diameter of pinhole in modeling, A is $>0.2\text{mm}$.	N.G.	Minor
7	Appearance of frame $A=(L+W) \div 2$	The folding angle of frame must be $>45^\circ +10^\circ$	N.G.	Minor
		The area of stripped electroplate in top-view of frame, A is $>1.0\text{mm}$.	N.G.	Minor
		Rust or crack is (Top view only)	N.G.	Minor
		The scratched width of frame is $>0.06\text{mm}$. (Top view only)	N.G.	Minor
8	Electrical characteristic of backlight $A=(L+W) \div 2$	The color of backlight is nonconforming	N.G.	Major
		Backlight can't work normally.	N.G.	Major
		The LED lamp can't work normally	N.G.	Major
		The unsoldering area of pin for backlight, A is $>1/2$ solder joint area.	N.G.	Minor
		The height of solder pin for backlight is $>2.0\text{mm}$	N.G.	Minor
10	Assembly parts $A=(L+W) \div 2$	The mark or polarity of component is unidentifiable.	N.G.	Minor
		The height between bottom of component and surface of the PCB is floating $>0.7\text{mm}$	N.G.	Minor
		$D > 1/4W$  <p>The diagram illustrates a component with width W and a pad with width D. The end solder joint width is labeled D'. The component is shown with a fillet of solder extending onto its body.</p>	N.G.	Minor
		End solder joint width, D' is $>50\%$ width of component termination or width of pad	N.G.	Minor
		Side overhang, D is $>25\%$ width of component termination.	N.G.	Minor
		Component is cracked, deformed, and burned, etc.	N.G.	Minor
		The polarity of component is placed in inverse direction.	N.G.	Minor
		Maximum fillet height of solder extends onto the component body or minimum fillet height is $<0.5\text{mm}$.	N.G.	Minor

4. RELIABILITY TEST

4.1 Reliability Test Condition

NO	Item	Test Condition	
1	High Temperature Storage	Storage at 80 ±2°C 96~100 hrs Surrounding temperature, then storage at normal condition 4hrs	
2	Low Temperature Storage	Storage at -30 ±2°C 96~100 hrs Surrounding temperature, then storage at normal condition 4hrs	
3	High Temperature /Humidity Storage	1.Storage 96~100 hrs 60 ±2°C , 90~95%RH surrounding temperature, then storage at normal condition 4hrs. (Excluding the polarizer). or 2.Storage 96~100 hrs 40 ±2°C , 90~95%RH surrounding temperature, then storage at normal condition 4 hrs.	
4	Temperature Cycling	$-20^{\circ}\text{C} \rightarrow 25^{\circ}\text{C} \rightarrow 70^{\circ}\text{C} \rightarrow 25^{\circ}\text{C}$ $\leftarrow (30\text{mins}) (5\text{mins}) (30\text{mins}) (5\text{mins}) \rightarrow$ <p style="text-align: center;">10 Cycle</p>	
5	Vibration	10~55Hz (1 minute) 1.5mm X,Y and Z direction * (each 2hrs)	
6	ESD Test	Air Discharge: Apply 6 KV with 5 times discharge for each polarity +/-	Contact Discharge: Apply 250V with 5 times discharge for each polarity +/-
		Testing location: Around the face of LCD	Testing location: 1.Apply to bezel. 2.Apply to Vdd, Vss.
7	Drop Test	Packing Weight (Kg)	Drop Height (cm)
		0 ~ 45.4	122
		45.4 ~ 90.8	76
		90.8 ~ 454	61
		Over 454	46

5. PRECAUTION RELATING PRODUCT HANDLING

5.1 SAFETY

- 5.1.1 If the LCD panel breaks , be careful not to get the liquid crystal to touch your skin.
- 5.1.2 If the liquid crystal touches your skin or clothes , please wash it off immediately by using soap and water.

5.2 HANDLING

- 5.2.1 Avoid any strong mechanical shock which can break the glass.
- 5.2.2 Avoid static electricity which can damage the CMOS LSI—When working with the module , be sure to ground your body and any electrical equipment you may be using.
- 5.2.3 Do not remove the panel or frame from the module.
- 5.2.4 The polarizing plate of the display is very fragile. So , please handle it very carefully ,do not touch , push or rub the exposed polarizing with anything harder than an HB pencil lead (glass , tweezers , etc.)
- 5.2.5 Do not wipe the polarizing plate with a dry cloth , as it may easily scratch the surface of plate.
- 5.2.6 Do not touch the display area with bare hands , this will stain the display area.
- 5.2.7 Do not use ketonics solvent & aromatic solvent. Use with a soft cloth soaked with a cleaning naphtha solvent.

5.3 STORAGE

- 5.3.1 Store the panel or module in a dark place where the temperature is $25^{\circ}\text{C} \pm 5^{\circ}\text{C}$ and the humidity is below 65% RH.
- 5.3.2 Do not place the module near organics solvents or corrosive gases.
- 5.3.3 Do not crush , shake , or jolt the module.

5.4 TERMS OF WARRANTY

5.4.1 Applicable warrant period

The period is within thirteen months since the date of shipping out under normal using and storage conditions.

5.4.2 Unaccepted responsibility

This product has been manufactured to your company's specification as a part for use in your company's general electronic products. It is guaranteed to perform according to delivery specifications. For any other use apart from general electronic equipment , we cannot take responsibility if the product is used in nuclear power control equipment , aerospace equipment , fire and security systems or any other applications in which there is a direct risk to human life and where extremely high levels of reliability are required.

