

1350V, 25A, Trench NPT IGBT

Features

- Trench NPT(Non Punch Through) IGBT
- High speed switching
- Low saturation voltage: $V_{CE(sat)}=2.0V@I_C=25A$
- High input impedance



Applications

- Inductive heating, Microwave oven, Inverter, UPS, etc.
- Soft switching applications

General Description

Using advanced Trench NPT technology, WOS's 1350V IGBTs offers superior conduction and switching performances, and easy parallel operation with exceptional avalanche ruggedness. This device is designed for soft switching applications.

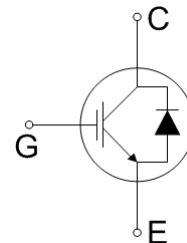

Absolute Maximum Ratings

Symbol	Description	Ratings	Units
V_{CES}	Collector to Emitter Voltage	1350	V
V_{GES}	Gate to Emitter Voltage	+/-30	V
I_C	Continuous Collector Current @ $T_C=25^{\circ}C$	50	A
	Continuous Collector Current @ $T_C=100^{\circ}C$	25	A
$I_{CM}(1)$	Pulsed Collector Current	90	A
I_F	Diode Continuous Forward Current @ $T_C=100^{\circ}C$	25	
I_{FM}	Diode Maximum Forward Current	150	A
P_D	Maximum Power Dissipation @ $T_C=25^{\circ}C$	312	W
	Maximum Power Dissipation @ $T_C=100^{\circ}C$	125	W
T_J	Operating Junction Temperature	-55 to +150	$^{\circ}C$
T_{stg}	Storage Temperature Range	-55 to +150	$^{\circ}C$
T_L	Maximum Lead Temp. for soldering Purposes, 1/8" from case for 5seconds	300	$^{\circ}C$

Notes:

1. Repetitive rating, Pulse width limited by max. junction temperature

Thermal Characteristics

Symbol	Parameter	Typ.	Max.	Units
$R_{\square JC}$	Thermal Resistance, Junction to Case	-	0.4	$^{\circ}C/W$
R_{JA}	Thermal Resistance, Junction to Ambient	-	40	$^{\circ}C/W$

Electrical Characteristics of the IGBT $T_C=25^{\circ}C$

Symbol	Parameter	Test Conditions	Min.	Typ.	Max.	Units
Off Characteristics						
BV_{CES}	Collector to Emitter Breakdown Voltage	$V_{GE}=0V, I_C=1mA$	1350	-	-	V
I_{CES}	Collector Cut-Off Current	$V_{CE}=1350V, V_{GE}=0V$	-	-	1	mA
I_{GES}	G-E Leakage Current	$V_{GE}=25V, V_{CE}=0V$	-	-	+/-250	nA
On Characteristics						
$V_{GE(th)}$	G-E Threshold Voltage	$I_C=25mA, V_{CE}=V_{GE}$	4.0	5.5	7.0	V
$V_{CE(sat)}$	Collector to Emitter Saturation Voltage	$I_C=25A, V_{GE}=15V$ $T_C=25^{\circ}C$	-	2	2.5	V
		$I_C=25A, V_{GE}=15V$ $T_C=125^{\circ}C$	-	2.15	-	V
Dynamic Characteristics						
C_{ies}	Input Capacitance	$V_{CE}=30V, V_{GE}=0V,$ $f=1MHz$	-	3700	-	pF
C_{oes}	Output Capacitance		-	130	-	pF
C_{res}	Reverse Transfer Capacitance		-	80	-	pF
Switching Characteristics						
$t_{d(on)}$	Turn-On Delay Time	$V_{CC}=600V, I_C=25A,$ $R_G=10\Omega, V_{GE}=15V,$ Inductive Load, $T_C=25^{\circ}C$	-	50	-	ns
t_r	Rise Time		-	60	90	ns
$t_{d(off)}$	Turn-Off Delay Time		-	190	-	ns
t_f	Fall Time		-	100	180	ns
E_{on}	Turn-On Switching Loss		-	4.1	6.2	mJ
E_{off}	Turn-Off Switching Loss		-	0.96	1.5	mJ
E_{ts}	Total Switching Loss		-	5.06	7.7	mJ
$t_{d(on)}$	Turn-On Delay Time	$V_{CC}=600V, I_C=25A,$ $R_G=10\Omega, V_{GE}=15V,$ Inductive Load, $T_C=125^{\circ}C$	-	50	-	ns
t_r	Rise Time		-	60	-	ns
$t_{d(off)}$	Turn-Off Delay Time		-	200	-	ns
t_f	Fall Time		-	154	-	ns
E_{on}	Turn-On Switching Loss		-	4.3	6.9	mJ
E_{off}	Turn-Off Switching Loss		-	1.5	2.4	mJ
E_{ts}	Total Switching Loss		-	5.8	9.3	mJ
Q_g	Total Gate Charge	$V_{CC}=600V, I_C=25A,$ $V_{GE}=15V$	-	200	300	nC
Q_{ge}	Gate to Emitter Charge		-	15	23	nC
Q_{gc}	Gate to Collector Charge		-	100	150	nC

Electrical Characteristics of Diode $T_C=25^\circ\text{C}$

Symbol	Parameter	Test Conditions	Min.	Typ.	Max.	Units	
V_{FM}	Diode Forward Voltage	$I_F=25\text{A}$	$T_C=25^\circ\text{C}$	-	2.0	3.0	V
			$T_C=125^\circ\text{C}$	-	2.1		V
t_{rr}	Diode Reverse Recovery Time		$T_C=25^\circ\text{C}$	-	235	350	ns
			$T_C=125^\circ\text{C}$	-	300		ns
I_{rr}	Diode Peak Reverse Recovery Current	$I_F=25\text{A},$ $di/dt=200\text{A}/\mu\text{s}$	$T_C=25^\circ\text{C}$	-	27	40	A
			$T_C=125^\circ\text{C}$	-	31		A
Q_{rr}	Diode Reverse Recovery Charge		$T_C=25^\circ\text{C}$	-	3130	4700	μC
			$T_C=125^\circ\text{C}$	-	4650		μC

Typical Performance Characteristics

Figure 1. Typical Output Characteristics

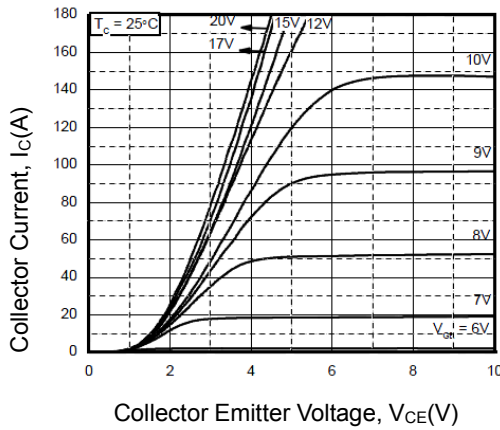

Figure 2. Typical Saturation Voltage Characteristics

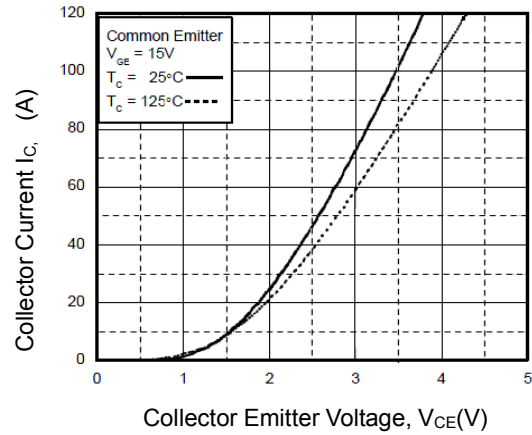

Figure 3. Saturation Voltage vs. Case Temperature at Variant Current Level

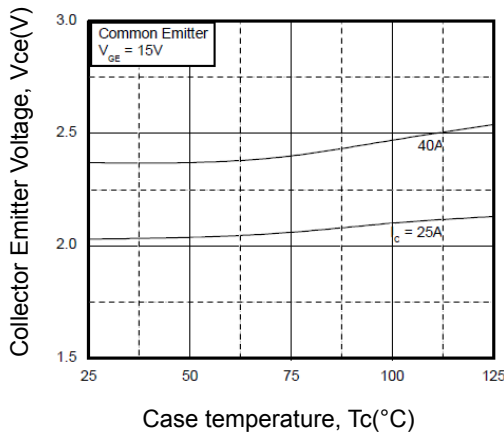

Figure 4. Saturation Voltage vs. Vge

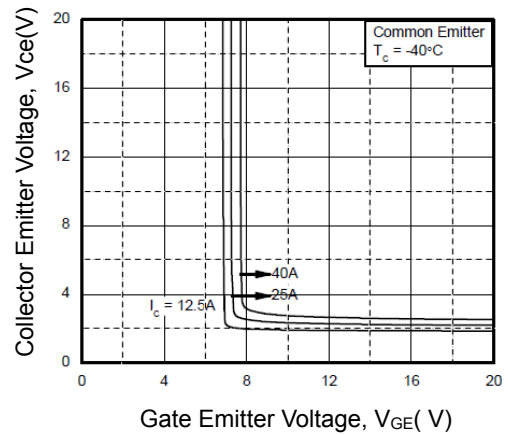

Figure 5. Saturation Voltage vs. Vge

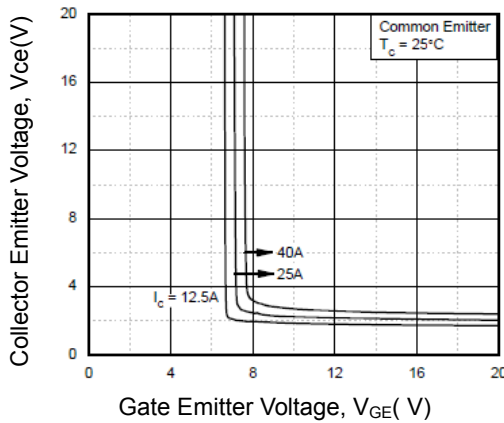
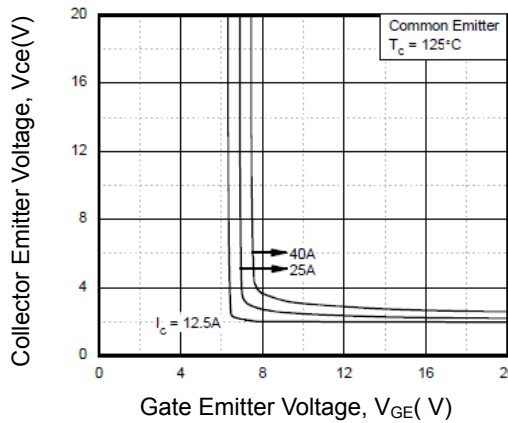

Figure 6. Saturation Voltage vs. Vge



Typical Performance Characteristics (Continued)

Figure 7. Capacitance Characteristics

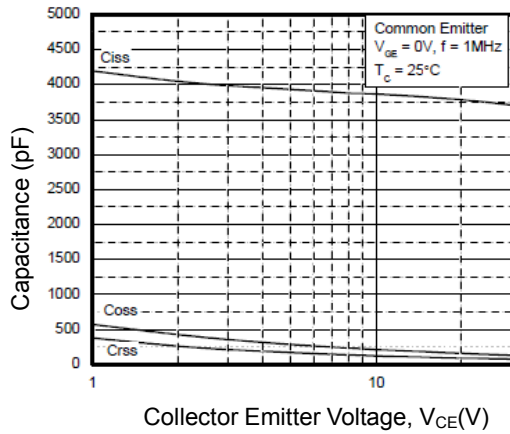

Figure 9. Turn-off Characteristics vs. Gate Resistance

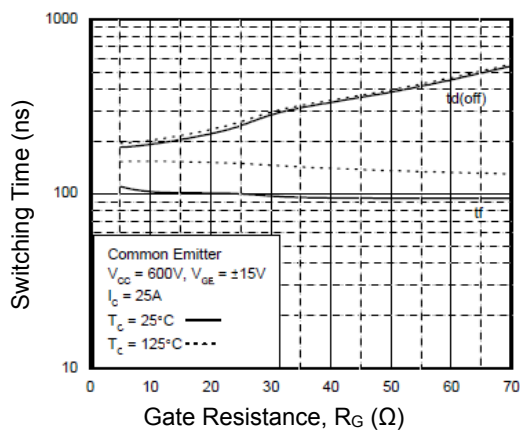

Figure 11. Turn-on Characteristics vs. Collector Current

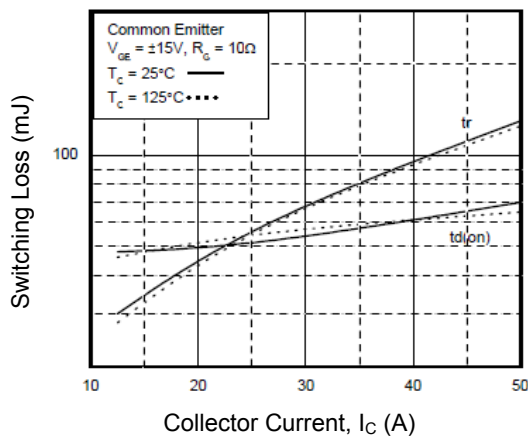

Figure 8. Turn-on Characteristics vs. Gate Resistance

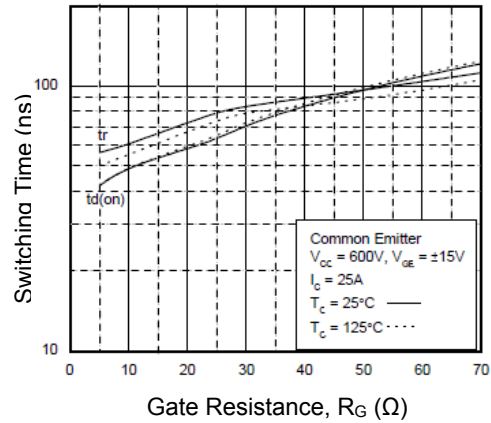

Figure 10. Switching Loss vs. Gate Resistance

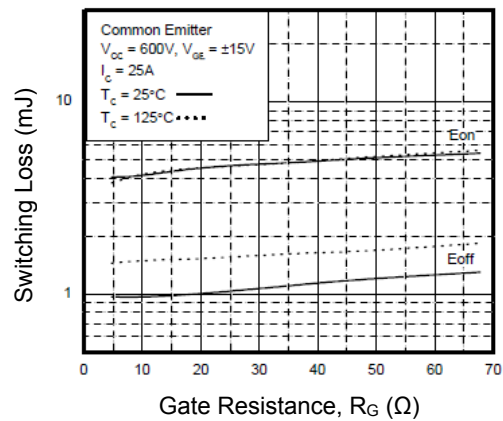
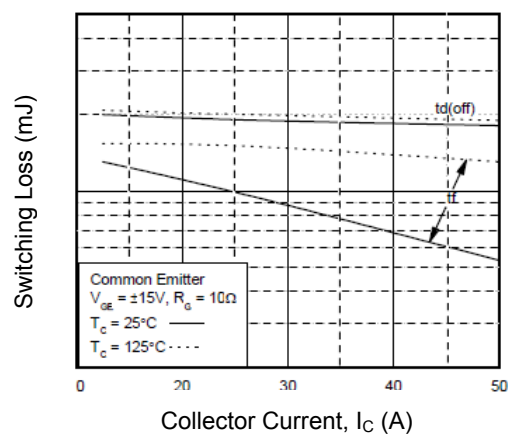

Figure 12. Turn-Off Characteristics vs. Collector Current



Typical Performance Characteristics (Continued)

Figure 13. Switching Loss vs. Collector Current

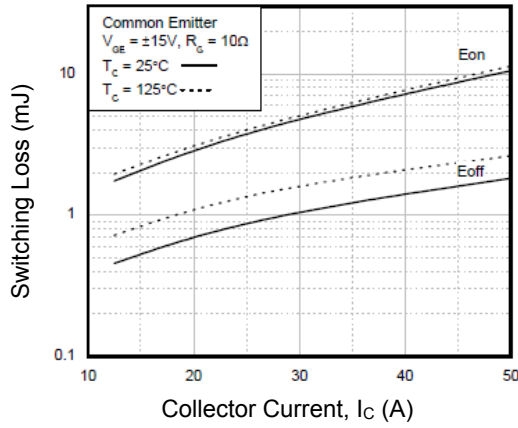

Figure 14. Gate Charge Characteristics

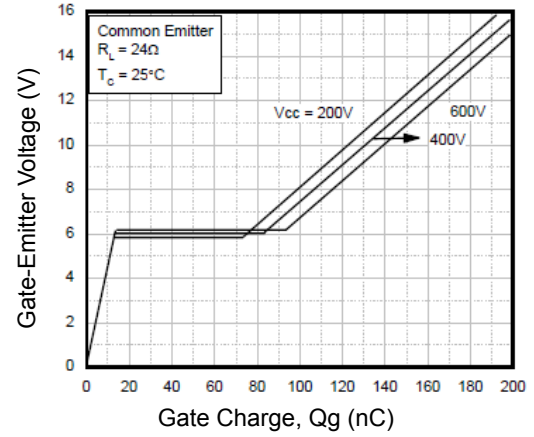

Figure 15. SOA Characteristics

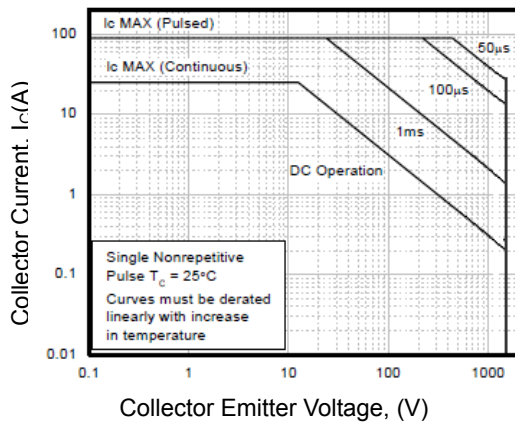

Figure 16. Turn-Off SOA

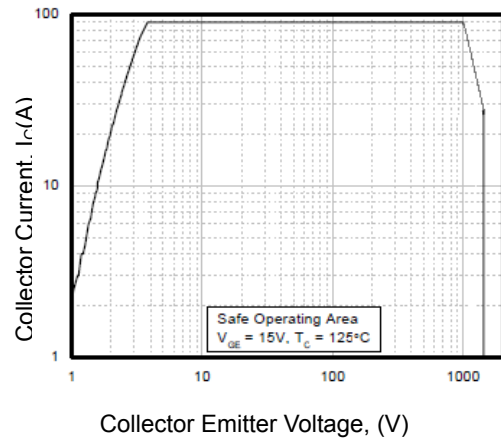

Figure 17. Transient Thermal Impedance of IGBT

