

## 1200V, 25A, Trench NPT IGBT

### Features

- Trench NPT( Non Punch Through) IGBT
- High speed switching
- Low saturation voltage:  $V_{CE(sat)}=2.0V@I_C=25A$
- High input impedance

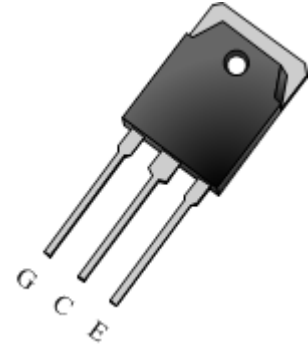

### Applications

- Inductive heating, Microwave oven, Inverter, UPS, etc.
- Soft switching applications

### General Description

Using advanced Trench NPT technology, WOS's 1200V IGBTs offers superior conduction and switching performances, and easy parallel operation with exceptional avalanche ruggedness. This device is designed for soft switching applications.

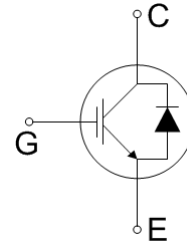

## Absolute Maximum Ratings

Symbol	Description	Ratings	Units
$V_{CES}$	Collector to Emitter Voltage	1200	V
$V_{GES}$	Gate to Emitter Voltage	+/-30	V
$I_C$	Continuous Collector Current @ $T_C=25^{\circ}C$	50	A
	Continuous Collector Current @ $T_C=100^{\circ}C$	25	A
$I_{CM}(1)$	Pulsed Collector Current	90	A
$P_D$	Maximum Power Dissipation @ $T_C=25^{\circ}C$	312	W
	Maximum Power Dissipation @ $T_C=100^{\circ}C$	125	W
$T_J$	Operating Junction Temperature	-55 to +150	$^{\circ}C$
$T_{stg}$	Storage Temperature Range	-55 to +150	$^{\circ}C$
$T_L$	Maximum Lead Temp. for soldering Purposes, 1/8" from case for 5seconds	300	$^{\circ}C$

#### Notes:

1. Repetitive rating, Pulse width limited by max. junction temperature

## Thermal Characteristics

Symbol	Parameter	Typ.	Max.	Units
$R_{\square JC}$	Thermal Resistance, Junction to Case	-	0.4	°C/W
$R_{JA}$	Thermal Resistance, Junction to Ambient	-	40	°C/W

## Electrical Characteristics of the IGBT $T_C=25^\circ\text{C}$

Symbol	Parameter	Test Conditions	Min.	Typ.	Max.	Units
<b>Off Characteristics</b>						
$BV_{CES}$	Collector to Emitter Breakdown Voltage	$V_{GE}=0V, I_C=1mA$	1200	-	-	V
$I_{CES}$	Collector Cut-Off Current	$V_{CE}=V_{CES}, V_{GE}=0V$	-	-	1	mA
$I_{GES}$	G-E Leakage Current	$V_{GE}=V_{GES}, V_{CE}=0V$	-	-	+/-250	nA
<b>On Characteristics</b>						
$V_{GE(th)}$	G-E Threshold Voltage	$I_C=25mA, V_{CE}=V_{GE}$	4.0	5.5	7.0	V
$V_{CE(sat)}$	Collector to Emitter Saturation Voltage	$I_C=25A, V_{GE}=15V$ $T_C=25^\circ\text{C}$	-	2	2.5	V
		$I_C=25A, V_{GE}=15V$ $T_C=125^\circ\text{C}$	-	2.15	-	V
<b>Dynamic Characteristics</b>						
$C_{ies}$	Input Capacitance	$V_{CE}=30V, V_{GE}=0V,$ $f=1MHz$	-	3700	-	pF
$C_{oes}$	Output Capacitance		-	130	-	pF
$C_{res}$	Reverse Transfer Capacitance		-	80	-	pF
<b>Switching Characteristics</b>						
$t_{d(on)}$	Turn-On Delay Time	$V_{CC}=600V, I_C=25A,$ $R_G=10\Omega, V_{GE}=15V,$ Resistive Load, $T_C=25^\circ\text{C}$	-	50	-	ns
$t_r$	Rise Time		-	60	90	ns
$t_{d(off)}$	Turn-Off Delay Time		-	190	-	ns
$t_f$	Fall Time		-	100	180	ns
$E_{on}$	Turn-On Switching Loss		-	4.1	6.2	mJ
$E_{off}$	Turn-Off Switching Loss		-	0.96	1.5	mJ
$E_{ts}$	Total Switching Loss		-	5.06	7.7	mJ
$t_{d(on)}$	Turn-On Delay Time	$V_{CC}=600V, I_C=25A,$ $R_G=10\Omega, V_{GE}=15V,$ Resistive Load, $T_C=125^\circ\text{C}$	-	50	-	ns
$t_r$	Rise Time		-	60	-	ns
$t_{d(off)}$	Turn-Off Delay Time		-	200	-	ns
$t_f$	Fall Time		-	154	-	ns
$E_{on}$	Turn-On Switching Loss		-	4.3	6.9	mJ
$E_{off}$	Turn-Off Switching Loss		-	1.5	2.4	mJ
$E_{ts}$	Total Switching Loss		-	5.8	9.3	mJ
$Q_g$	Total Gate Charge	$V_{CC}=600V, I_C=25A,$ $V_{GE}=15V$	-	200	300	nC
$Q_{ge}$	Gate to Emitter Charge		-	15	23	nC
$Q_{gc}$	Gate to Collector Charge		-	100	150	nC

## Typical Performance Characteristics

Figure 1. Typical Output Characteristics

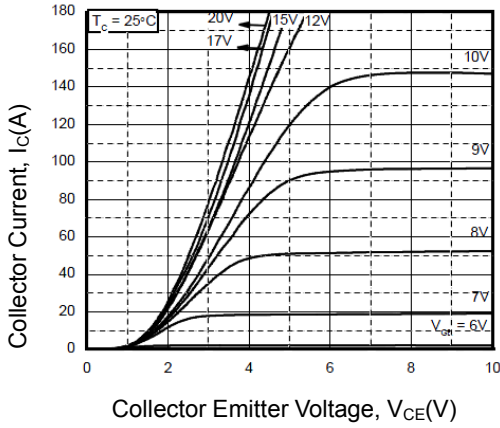

Figure 2. Typical Saturation Voltage Characteristics

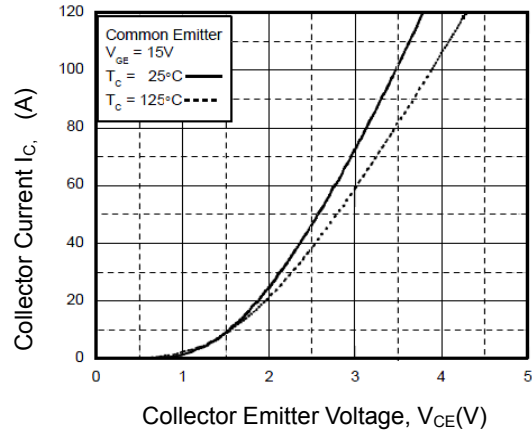

Figure 3. Saturation Voltage vs. Case Temperature at Variant Current Level

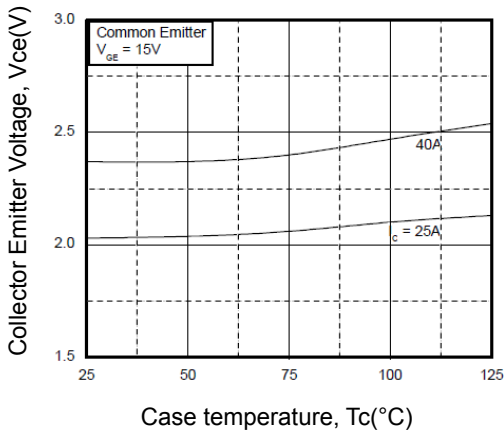

Figure 4. Saturation Voltage vs.  $V_{GE}$

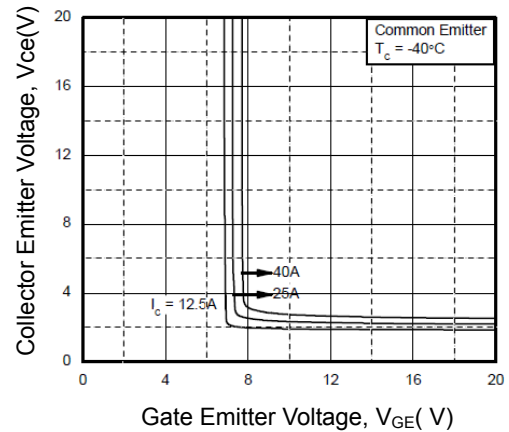

Figure 5. Saturation Voltage vs.  $V_{GE}$

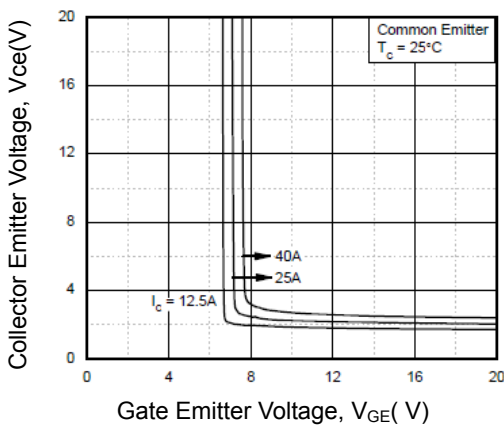
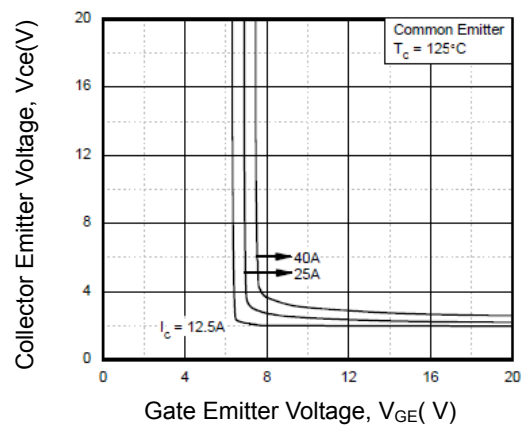

Figure 6. Saturation Voltage vs.  $V_{GE}$



## Typical Performance Characteristics (Continued)

Figure 7. Capacitance Characteristics

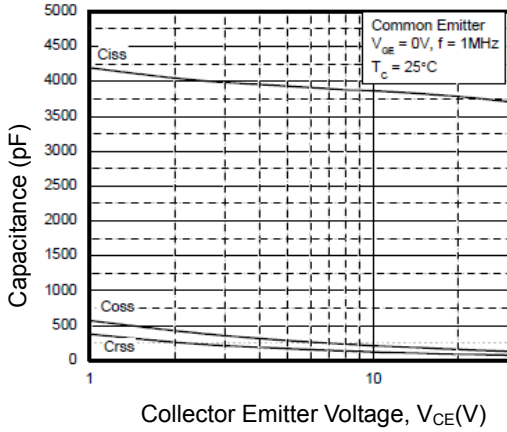

Figure 8. Turn-on Characteristics vs. Gate Resistance

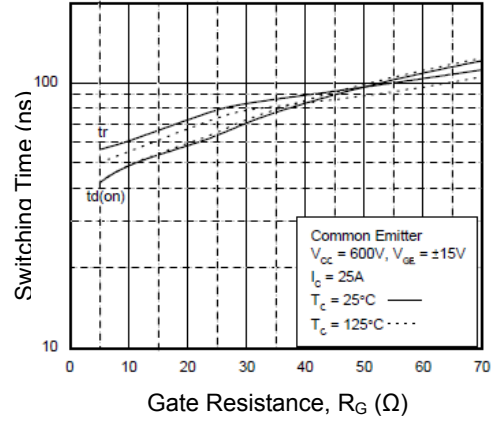

Figure 9. Turn-off Characteristics vs. Gate Resistance

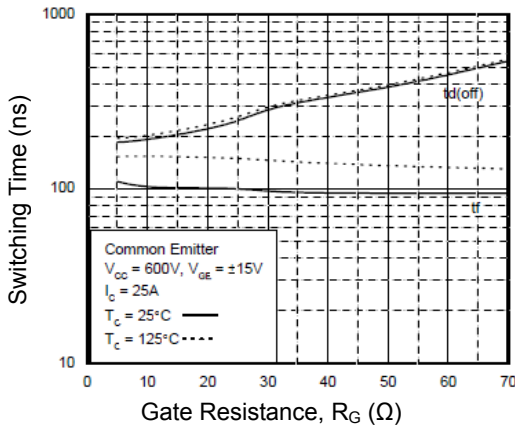

Figure 10. Switching Loss vs. Gate Resistance

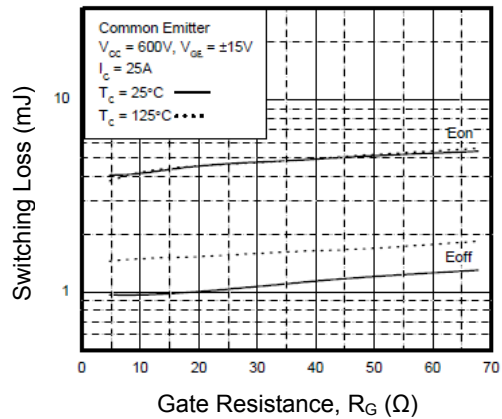

Figure 11. Turn-on Characteristics vs. Collector Current

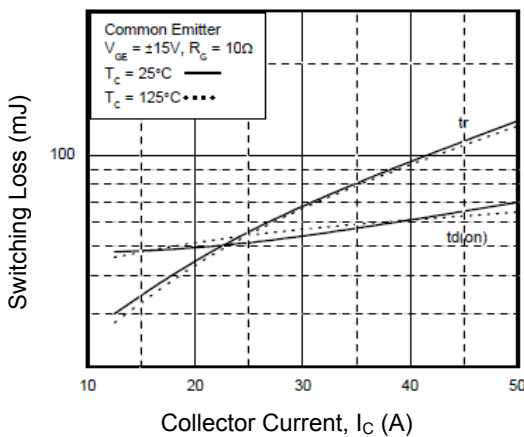
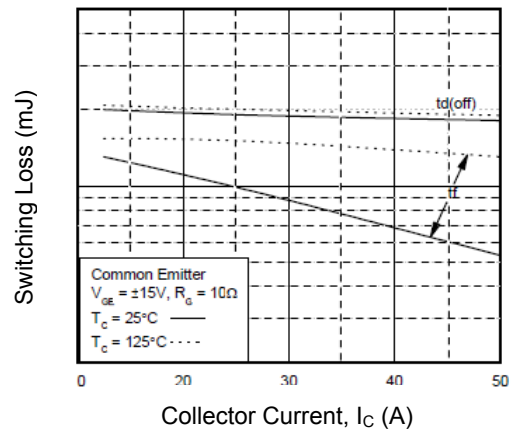

Figure 12. Turn-Off Characteristics vs. Collector Current



## Typical Performance Characteristics (Continued)

Figure 13. Switching Loss vs. Collector Current

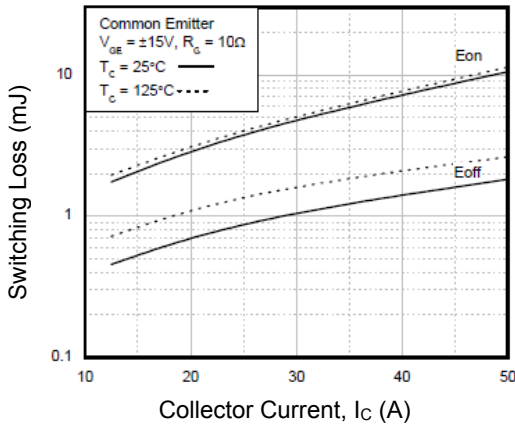

Figure 14. Gate Charge Characteristics

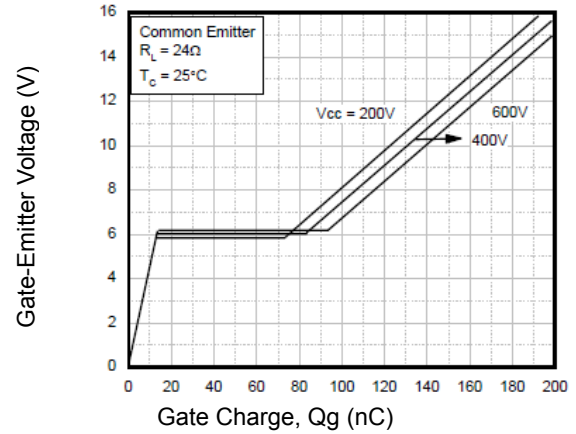

Figure 15. SOA Characteristics

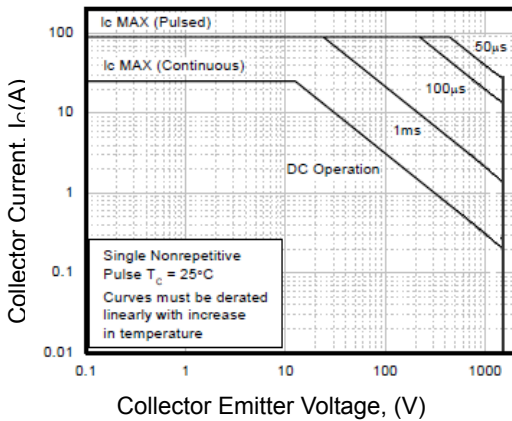

Figure 16. Turn-Off SOA

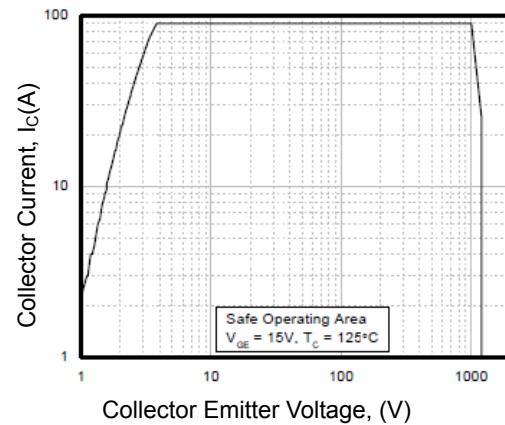

Figure 17. Transient Thermal Impedance of IGBT

